



**RULES
FOR THE CLASSIFICATION AND CONSTRUCTION
OF SEA-GOING SHIPS**

**PART II
HULL**

July
2024

GDAŃSK

RULES FOR CLASSIFICATION AND CONSTRUCTION OF SEA-GOING SHIPS

prepared and issued by Polish Register of Shipping, hereinafter referred to as PRS, consist of the following parts:

- Part I – Classification Regulations
- Part II – Hull
- Part III – Hull Equipment
- Part IV – Stability and Subdivision
- Part V – Fire Protection
- Part VI – **Ship and Machinery Piping Systems**
- Part VII – **Main and auxiliary machinery and equipment**
- Part VIII – Electrical Installations and Control Systems
- Part IX – Materials and Welding

Part II – Hull – July 2024, was approved by the PRS Board on 20 June 2024 and enters into force on 1 July 2024. From the entry into force, the requirements of *Part II – Hull* apply, in full, to new ships.

With respect to existing ships, the requirements of *Part II – Hull* are applicable within the scope specified in *Part I – Classification Regulations*.

The requirements of *Part II – Hull* are extended by the following Publications:

- Publication 9/P – Requirements for Computer Based Systems,
- Publication 11/P – Environmental Tests on Marine Equipment,
- Publication 14/P – Principles of Approval of Computer Programs,
- Publication 16/P – Loading Guidance Information,
- Publication 17/P – Zone Strength Analysis of Hull Structure of Roll on/ Roll off Ship,
- Publication 18/P – Zone Strength Analysis of Bulk Carrier Hull Structure,
- Publication 19/P – Zone Strength Analysis of Hull Structure in Tankers,
- Publication 20/P – Ship Side Strengthening of Fishing Vessels Mooring at Sea Alongside Other Vessels,
- Publication 21/P – Testing of Hull Structures,
- Publication 24/P – Strength Analysis of Container Ship Hull Structure,
- Publication 32/P – The Requirements for Stowage and Securing of Cargo on Sea-Going Ship,
- Publication 39/P – Hull Survey of Bulk Carriers,
- Publication 40/P – Non-Metallic Materials,
- Publication 45/P – Fatigue Strength Analysis of Ship Steel Hull Structure,
- Publication 48/P – Requirements Concerning Gas Tankers
- Publication 50/P – Technical Requirements Concerning Sea Environment Protection for Sea-Going Ships.
- Publication 55/P – Survey of Corrosion Protection and Anti-fouling Systems,
- Publication 63/P – Replacement Criteria for Side Shell Frames and Brackets in Single Side Skin Bulk Carriers and Oil-Bulk-Ore Carriers,
- Publication 76/P – Stability, Subdivision and Freeboard of Passenger Ships Engaged on Domestic Voyages,
- Publication 100/P – Safety requirements for sea-going passenger ships and high-speed passenger craft engaged in domestic voyages,
- Publication 103/P – Guidelines for energy efficiency of ships,
- Publication 106/P – Eco Class Rules,
- Publication 114/P – Longitudinal Strength Standard for Container Ships,
- Publication 118/P – Requirements for passenger ships constructed of polymer composites, engaged on domestic voyages,
- Publication 122/P – Requirements for Ice Baltic Class and Polar Class for Ships under PRS Supervision
- Publication 2/I – Prevention of Vibration in Ships,
- Publication 16/I – Shipbuilding and Repair Quality Standards,
- Publication 31/I – Regulations for Safe and Environmentally Sound Recycling of Ships,
- Publication 35/I – Wave loads on Ships,
- Publication 36/I – Recommendation for assessing alternative methods used in the hull structural design of ships subject to the Common Structural Rules for Bulk Carriers and Oil Tankers.

© Copyright by Polish Register of Shipping*, 2024

* *Polish Register of Shipping* means *Polski Rejestr Statków S.A.*, seated in *Gdańsk, al. gen. Józefa Hallera 126, 80-416 Gdańsk, Poland*, registered in the Register of Entrepreneurs of the National Court Register, under entry number 0000019880. Polish Register of Shipping, its affiliates and subsidiaries, their respective officers, employees or agents are, individually and collectively, referred to as Polish Register of Shipping or as PRS for short.

CONTENTS

	Page
1 General	7
1.1 Application.....	7
1.2 Definitions and Explanations.....	7
1.3 Survey and Classification.....	12
1.4 Technical Documentation	13
1.5 Ergonomic Considerations.....	16
2 Materials and Protection Against Corrosion	17
2.1 General.....	17
2.2 Hull Structural Steels	17
2.3 Other Structural Materials.....	23
2.4 Corrosion Protection	23
2.5 Corrosion Additions.....	25
2.6 Anti-fouling systems.....	26
3 Structure Particulars	28
3.1 General.....	28
3.2 Modelling of Structural Members.....	28
3.3 Details of Welded Structures	33
3.4 Structure Continuity.....	34
3.5 Openings in Structural Members	34
3.6 Construction of T-Section Primary Supporting Members.....	35
3.7 Construction of water ballast tanks	37
4 Joints of Structural Elements	38
4.1 General.....	38
4.2 Types and Size of Welds.....	38
4.3 End Connections of Structural Members	43
4.4 Connection of Different Material Structures.....	45
5 Principles of Hull Structural Requirements	46
5.1 General.....	46
5.2 Basis for Requirements	47
6 Bottom Structures	50
6.1 General.....	50
6.2 Double Bottom Structure	52
6.3 Scantlings of the Double Bottom	56
6.4 Single Bottom Structural Arrangement.....	59
6.5 Scantlings of Single Bottom	60
6.6 Common Requirements for Ships with Single and Double Bottom.....	62
6.7 Bottom Strengthening in the Forebody	62
7 Side Structures	66
7.1 General.....	66
7.2 Structural Arrangement.....	67
7.3 Scantlings of Structural Members.....	68
7.4 Strengthening of the Forebody.....	71
8 Decks	74
8.1 General.....	74
8.2 Structural Arrangement.....	74
8.3 Scantlings of Structural Members.....	75

8.4	Additional Requirements	77
8.5	Openings in Decks	78
8.6	Coamings	79
8.7	Pillars	81
8.8	Helicopter	Decks
	Błąd
	! Nie zdefiniowano zakładek.	
9	Bulkheads	85
9.1	General.....	85
9.2	Subdivision	85
9.3	Structural Arrangement.....	89
9.4	Scantlings of Structural Members.....	90
9.5	Additional Requirements	91
10	Superstructures	92
10.1	General.....	92
10.2	Structural Arrangement.....	92
10.3	Scantlings of Structural Members.....	93
10.4	Design Loads on Walls	95
10.5	Bulwarks	95
11	Stem and Sternframe	98
11.1	General.....	98
11.2	Stem	98
11.3	Sternframe.....	99
11.4	Clearances between Propeller and Hull	107
11.5	Fixed Nozzles.....	108
11.6	Rudder Trunk.....	111
12	Seatings.....	113
12.1	General.....	113
12.2	Structure and Scantlings of Structural Members.....	113
13	Local Strength and Buckling Control of the Structure.....	115
13.1	General.....	115
13.2	Minimum Thickness	116
13.3	Buckling Control of Structural Elements	118
13.4	Hull Plating	122
13.5	Stiffeners.....	128
13.6	Simple Primary Supporting Members.....	134
13.7	Pillars and Supporting Members.....	136
13.8	Brackets	137
14	Zone, General and Local Strength, the Principles of Finite Elements Method Calculations	142
14.1	General.....	142
14.2	Design Load Conditions.....	142
14.3	Hull Primary Supporting Members System Strength Assessment on the Basis of Beam FE Models.	142
14.4	Hull Primary Supporting Member System Strength Assessment on the Basis of FE Models Using Membrane, Shell and Beam Finite Elements.....	146
14.5	Assessment of Stress Level in Primary Supporting Members	151
14.6	Assessment of the Hull General Strength with the Use of FE Method	153
14.7	Assessment of Stress Level in Stress Concentration Areas and in the Plating Stiffeners (Local FE Models).....	157

15 Longitudinal Strength	161
15.1 General.....	161
15.2 Hull Section Modulus	163
15.3 Moment of Inertia of Hull Cross-section	164
15.4 Still Water Bending Moment	164
15.5 Wave Bending Moment	168
15.6 Extent of High Strength Steel Application.....	169
15.7 Geometrical Data on Hull Cross-section as Built	170
15.8 Shear Strength.....	172
15.9 Still Water Shear Forces	173
15.10 Wave Shear Forces.....	173
15.11 Requirements for Structures Subjected to Shear Forces	175
15.12 Shear Force Corrections.....	176
15.13 Ship Loading Control.....	178
15.14 Buckling strength of hull structure subject to hull girder stresses.....	186
16 Local Loads of Structure	184
16.1 General.....	184
16.2 Sea Pressures.....	185
16.3 Pressure of Liquids in Tanks.....	187
16.4 Cargo Loads.....	188
17 Ship Motions	192
17.1 General.....	192
17.2 Definitions	192
17.3 Amplitudes of Ship Motions	193
17.4 Resultant Acceleration Amplitudes.....	194
18 Container Carriers	195
18.1 General.....	195
18.2 Materials and Welding.....	195
18.3 Structure.....	196
18.4 Hull Strength Analysis.....	197
18.5 Design Loads, Loading Conditions.....	197
18.6 Brittle Crack Arrest Design.....	200
19 Passenger Ships, Ferries and Ro-ro Ships	204
19.1 General.....	204
19.2 Materials and Welding.....	206
19.3 Zone Strength.....	206
19.4 Permanent Decks for Wheel Loading	206
19.5 Car Decks.....	211
19.6 Design Loads	213
20 Bulk Carriers	219
20.1 General.....	219
20.2 Local Strength.....	223
20.3 Zone Strength.....	223
20.4 Longitudinal Strength and Fatigue Strength	224
20.5 Side Structures in Single Side Ships	225
20.6 Longitudinal Strength of Hull in Flooded Condition	228
20.7 Evaluation of Scantlings of Corrugated Transverse Watertight Bulkheads in Bulk Carriers Considering Hold Flooding	230
20.8 Evaluation of Allowable Hold Loading for Bulk Carriers Considering Hold Flooding	243
20.9 Design Loading Conditions and Corresponding Descriptive Information.....	248
20.10 Requirements for Forecastle.....	252
20.11 Requirements for Ships with Double-side Skin Construction.....	253
20.12 Requirements for Cargo Area Structure of Hull.....	254

21 Tankers	257
21.1 General.....	257
21.2 General Arrangement.....	258
21.3 Materials and the Scantlings of Structural Members	265
22 Fishing Vessels	271
22.1 General.....	271
22.2 Structural Design and Scantlings of Structural Members	271
22.3 Stern Trawlers.....	272
22.4 Side Trawlers	276
23 Tugs and Supply Vessels	277
23.1 General.....	277
23.2 Tugs	277
23.3 Supply Vessels.....	278
24 Dredgers, Hopper Barges and Floating Cranes	282
24.1 General.....	282
24.2 Structural Design and Scantlings of Structural Members of Dredgers and Hopper Barges.....	282
24.3 Structural Design and Scantlings of Structural Members of Floating Cranes.....	282
25 Catamarans	283
25.1 General.....	283
25.2 Materials and Welding.....	284
25.3 Subdivision	284
25.4 Construction.....	285
25.5 Hull Structure Strength	288
25.6 Design Loads	292
26 Ice and Special StrengtheniNGS	299
26.1 General.....	299
26.2 Strengthenings in Ships Unloaded with Grabs.....	299
26.3 Strengthenings in Ships Lying Aground during Loading Operations	299
27 Additional Requirements for Ships which Occasionally Carry Dry Cargoes in Bulk and Are Not Classified as Bulk Carriers	300
27.1 Application.....	300
27.2 Ship of Double-side Skin Construction.....	300
27.3 Ship of Single-side Skin Construction	300
28 Additional Requirements for Energy Efficient Ships	301
28.1 Application.....	301
28.2 Required Documentation	301
28.3 Additional Mark in the Symbol of Class.....	301
29 Oil Recovery Vessels	302
29.1 General.....	302
29.2 Definitions	302
29.3 Space Division	303
29.4 Tank Structure.....	303
30 Ballast Water Exchange At Sea	304
30.1 General.....	304
30.2 Ballast Water Management.....	304
SUPPLEMENT – Retroactive RequirEMENTS	305
ANNEX 1	324
ANNEX 2	327
ANNEX 3	329

1 GENERAL

1.1 Application

1.1.1 *Part II – Hull* applies to steel, welded hulls of sea-going ships specified in paragraph 1.1.1, *Part I – Classification Regulations*, except bulk carriers and oil tankers, referred to below.

For bulk carriers of $L_0 \geq 90$ m the requirements specified in Common Structural Rules (CSR) shall be applied.

The requirements of Chapter 20 apply to bulk carriers as defined in SOLAS (i.e. also covering ore carriers and combination carriers). Some paragraphs of that Chapter also apply to ships who are subject to the requirements specified in Common Structural Rules (CSR).

For double hull oil tankers of 150 m in length and above, the requirements specified in CSR shall apply.

1.1.2 Allowable ranges of the ship main dimensions and their ratios are specified, where necessary, in chapters regarding particular types of ships. Ships and structures of unconventional design or those not complying with the limitations imposed on the main parameters, specified in the present Part of the *Rules for the Classification and Construction of Sea-going Ships* (hereinafter referred to as the *Rules*), are subject to PRS consideration in each particular case.

1.1.3 The present Part of the *Rules* may be also applied to structures made of aluminium alloys.

1.1.4 The present Part of the *Rules* includes both basic and additional requirements. Compliance with the basic requirements (Chapters 1÷17), where applicable, is necessary for assignment of the main symbol of class.

Additional marks in the symbol of class determining the designation of a ship, application of ice strengthening and adaptation of the hull structure to special operating conditions will be affixed, provided the additional requirements are complied with, where applicable.

1.1.5 Hull is subject to the guidelines for safe and environmentally sound recycling in the scope specified in *Publication 31/I – Regulations for Safe and Environmentally Sound Recycling of Ships*.

1.2 Definitions and Explanations

1.2.1 General

Definitions concerning general terminology used in the *Rules* are given in *Part I – Classification Regulations*. In the present Part of the *Rules*, additional definitions relating to the ship's hull have been adopted.

1.2.2 Definitions

A.P. – *after perpendicular* – the perpendicular at the centre plane, at distance L_0 from *F.P.*, in aft direction.

B – *moulded breadth of the ship*, [m] – the greatest breadth measured between the outer edges of frames.

B_s – *moulded breadth of the ship at scantling draught*, [m] – the greatest moulded breadth measured amidships at the scantling draught T_s .

B.P. – *base plane* – horizontal plane which crosses amidships the top of a flat keel or the intersection of the inner surface of the plating with the bar keel.

- CP* – ship centre plane.
- D* – moulded displacement, [t] – mass of water, in tonnes, of the volume equal to the volume of the submerged part of the ship’s hull at draught *T*. Unless otherwise stated, the sea water density equal to 1.025 t/m³ shall be taken.
- E* – elasticity (Young) modulus, [MPa] – for steel, $E = 2.06 \cdot 10^5$ [MPa] shall be taken.
- F.P.* – forward perpendicular – the perpendicular at the intersection of the waterline at scantling draught with the fore side of the stem. For ships with unconventional stem curvature, the position of the forward perpendicular is subject to PRS acceptance in each particular case.
- g* – standard acceleration of gravity, [m/s²] – may be taken as equal to 9.807 m/s².
- G* – shear (Kirchhoff) modulus, [MPa] – for steel, $G = 7.9 \cdot 10^4$ MPa shall be taken.
- H* – moulded depth, [m] – the vertical distance measured amidships from the base plane to the top of the uppermost continuous deck beam at side. In ships having a rounded gunwale, the moulded depth shall be measured to the point of intersection of the moulded lines of the deck and side.
- If the uppermost continuous deck is stepped and the raised part of the deck extends over the point at which the moulded depth is determined, the moulded depth shall be measured to a line of reference extending from the lower part of the deck along a line parallel with the raised part.
- k* – material factor – a factor depending on the yield point of the material – see 2.2.1.
- L* – length of the ship, [m] – 96% of the total length of hull measured on the waterline at 85% of the least moulded depth measured from the top of the keel, or the length from the fore side of the stem to the axis of the rudder stock on that waterline, whichever is greater. Where the stem line in the ship’s centre plane is concave above that waterline, both the stem outer point of the total length of hull and the fore side of the stem shall be taken at the point determined by vertical projection – on such a waterline plane – of the aftermost point on the stem line above that waterline (see Fig. 1.2.2). In ships designed with a rake of keel, the waterline on which this length is measured shall be parallel to the design waterline.

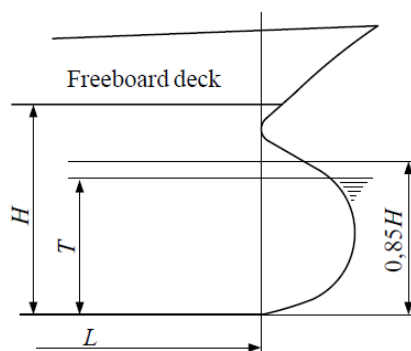

Fig. 1.2.2. Definition of length of ship *L* for ships with unconventional stem curvature

- L_{pp} – length between perpendiculars, [m] – the distance between the fore and aft perpendicular.
- L_W – length of summer load waterline, [m] – the distance measured at this waterline from the fore side of the stem to the point of intersection of the waterline with after side of the stern (transom).

L_0 – *design length of the ship (the Rule length)*, [m] – the distance measured on the waterline at the scantling draught, from the fore side of the stem to the after side of the rudder post, or the centre of the rudder stock if there is no rudder post. L_0 is not to be less than 96%, and need not be greater than 97% of the extreme length on the waterline at the scantling draught.

In ships without rudder stock (e.g. ships fitted with azimuth thrusters), the Rule length L_0 is to be taken equal to 97% of the extreme length on the waterline at the scantling draught T_s .

In ships with unusual stern and bow arrangement, length L_0 is subject to PRS acceptance in each particular case.

R_e – *material yield point*, [MPa] – see explanations in *Part IX – Materials and Welding*.

T – *moulded draught*, [m] – the vertical distance measured amidships from the base plane to the summer load waterline.

T_s – *scantling draught*, [m] – the draught at which the strength requirements for the scantlings of the ship are met and represents the full load condition. The scantling draught is to be not less than the moulded draught T and the draught corresponding to the assigned freeboard.

V – *volume of the moulded displacement*, [m³] – the volume of a body defined by the external edges of frames at draught T .

V_s – *volume of the moulded displacement at scantling draught*, [m³] – the volume of a body defined by the external edges of frames at draught T_s .

x, y, z – *co-ordinates of a point in the ship*, [m] – see 1.2.3.

δ – *block coefficient* – the moulded block coefficient corresponding to the load waterline at the scantling draught T_s , determined in accordance with the formula:

$$\delta = \frac{V_s}{L_0 B_s T_s}$$

v – *ship speed*, [knots] – the maximum service speed at draught T .

1.2.3 Co-Ordinate System

1.2.3.1 In the present Part of the *Rules*, the co-ordinate system, shown in Fig. 1.2.3.1, has been assumed for ships. The following reference planes have been assumed for the system: base plane, centre plane and midship section.

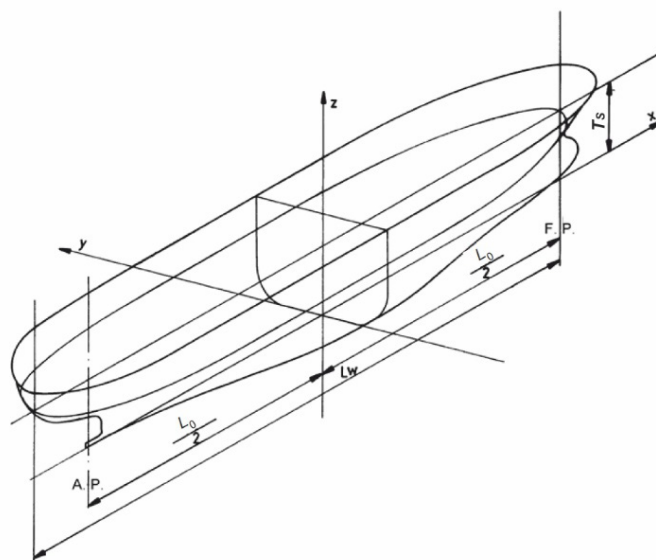

Fig. 1.2.3.1. Ship co-ordinate system

The intersection of the centre plane and the base plane forms x axis of the positive sense forward.
The intersection of the base plane and midship section forms y axis of the positive sense towards port side.

The intersection of the centre plane and midship section forms z axis of the positive sense upwards.

1.2.3.2 Other ship co-ordinate systems, specified separately, are also applicable to the present Part of the Rules.

1.2.4 General Definitions

Bulkhead deck – the uppermost deck to which the main watertight bulkheads, dividing the ship into compartments, are carried (see requirements of resolution *MSC.421(98)*, paragraph 7 and resolution *MSC.429(98) Rev.2*, - Revised Explanatory Notes to the SOLAS Chapter II-1, Subdivision and Damage Stability Regulation”).

Deck erection – a superstructure or deckhouse.

Deckhouse – a decked structure on the freeboard deck or on the superstructure deck with the sides being inboard of one or both ship sides more than $0.04B$.

Deepest subdivision draught – the summer load line draught of the ship.

Freeboard deck – the deck to which the freeboard is measured and calculated in accordance with the *International Convention on Load Lines, 1966*.

Lower deck, tween deck – the deck situated below the upper deck. Where there are several lower decks, they are named: the second deck, the third deck, etc., counting from the upper deck.

Machinery spaces – see definition in *Part V* of the Rules.

Midship portion – the ship portion of length equal to $0.4L_0$ (within $-0.2L_0 < x < 0.2L_0$) symmetrical in relation to the midship section. Where the extent of the portion in question is different, its co-ordinates are specified in each particular case.

Midship section – a curve being the result of hull surface cross-section with the vertical plane normal to the centre plane, situated in the middle of length L_0 .

Moulded deck line – intersection line of surfaces defined by the external edges of deck beams and side frames. In the case of rounded deck corner, this is an intersection of extensions of these surfaces.

Platform deck – structure extending over a part of the ship's length or breadth similar to the lower deck; need not be watertight.

Ship's end – a portion of the ship within $x < -0.4L_0$ or $x > 0.4L_0$. Where the extent of a portion in question is different, its co-ordinates are specified in each particular case.

Strength deck – the upper deck. Where it is covered by a midship superstructure which has the length not less than $3(0.5B + h)$, the midship superstructure deck is considered as the strength deck within this portion (h [m] – the vertical distance between the upper deck and midship superstructure deck in question). Any other deck may be defined as the strength deck within the given length of the ship subject to PRS acceptance of continuity of the ship's sides with respect to shear strength in each particular case.

Summer load waterline – the waterline corresponding to the Summer Load Line defined in accordance with the Regulations of the *International Convention on Load Lines, 1966*.

Superstructure – a decked structure on the freeboard deck, extending from side to side of the ship or with one side or both sides being inboard of the ship sides not more than $0.04B$.

The following definitions are applied to the erections with regard to their location on board the ship:

Forecastle – an erection extending aft of the bow.

Poop – an erection extending forward of the stern.

Midship superstructure – an erection located partly or totally within the midship portion of the ship; it may be an extension of the forecastle or the poop.

Superstructure (deckhouse) deck – the deck forming the top of a superstructure (deckhouse). Where the superstructure (deckhouse) is divided into several tiers, the superstructure (deckhouse) decks are named: first tier superstructure (deckhouse) deck, second tier superstructure (deckhouse) deck, etc., counting from the upper deck.

Upper deck – the uppermost continuous deck extending over the full length of the ship.

Weather deck – each deck or part thereof, which may be exposed to the effects of sea and weather.

1.2.5 Definitions of Structural Members

Bulkhead structure – transverse or longitudinal bulkhead plating, including stiffeners and primary supporting members.

Deck structure – deck plating, including stiffeners and primary supporting members.

Double bottom structure – shell plating and inner bottom plating including stiffeners, primary supporting members and other elements below the top of the inner bottom.

Primary supporting members – a general name for structural members supporting the stiffener systems or other primary supporting members.

Main frames – side frames located outside the peak area connected to the floors or the double bottom and carried to the lowest deck or side stringer if it is regarded as the frame support.

Side structure – shell plating, including stiffeners and primary supporting members, between the uppermost deck reaching the side and upper turn of bilge in the case of single bottom or inner bottom plating in the case of double bottom.

Simple primary supporting member – a primary supporting member, the conditions of ends fixation of which are known with sufficient accuracy and therefore it may be regarded as a member separated from the adjacent structure.

Single bottom structure – shell plating with stiffeners and primary supporting members below the upper turn of the bilge.

Stiffener – a general name for structural members supporting directly the plating.

Structural members – a general term used for such ship structures as the plating, the plating stiffeners and primary supporting members.

Superstructure (deckhouse) structure – wall and deck plating, including the stiffeners and primary supporting members.

Tween deck frames – frames located between the supporting side stringers, between the supporting side stringer and the nearest deck or between the two decks, including superstructure decks.

Wash bulkhead – a perforated or partial bulkhead in a tank.

Watertight – capable of preventing the passage of water in any direction under the head of water likely to occur in intact and damage conditions.

Watertight bulkhead – a transverse bulkhead dividing the hull into watertight compartments.

Weathertight – the term pertaining to closing appliances of openings in the above water part of ship, which means that in any sea condition water will not penetrate through these openings.

Further on in the present Part of the *Rules*, the general names for structural members as defined above (primary supporting members, stiffener) are used interchangeably with traditional terms associated with the location and function of a given member (e.g. frame, longitudinal, beam, stringer, floor).

1.2.6 Other Definitions

The definitions specific for particular chapters or sub-chapters of the present Part of the *Rules* are given in these chapters and sub-chapters.

1.3 Survey and Classification

1.3.1 Survey and classification are performed in accordance with the regulations specified in *Part I – Classification Regulations*.

1.3.2 Survey under construction covers the hull structure as a whole, together with the below specified parts:

- superstructures and deckhouses,
- trunks and propeller shaft tunnels,
- seatings for main engines and bearers for boilers,
- seatings for auxiliary engines and associated machinery components subject to PRS' survey,
- shaft brackets, fixed propeller nozzles,
- coamings, companionways and other boundaries of openings in hull,
- movable ramps and platforms.

1.3.3 During construction, the structures, listed in paragraph 1.3.2, are subject to survey with regard to:

- compliance with the approved technical documentation,
- compliance with the requirements of the present Part of the *Rules* within the scope not indicated in the technical documentation,
- compliance with the requirements specified in *Part IX – Materials and Welding*.

1.3.4 Hulls of all ships under construction shall be subjected to the tightness and strength tests within the scope and using the methods specified in *Publication 21/P – Testing of Hull Structures*.

1.3.5 PRS' survey may also include problems related to prevention of the ship's hull vibration as specified in *Publication 2/I – Prevention of Vibration in Ships*.

1.3.6 For ships assigned additional mark **PAC** in the symbol of class in accordance with 2.4.4, complete documentation of the corrosion protection system shall be submitted for approval. The scantlings of structural members with and without the corrosion allowances shall be indicated in the design drawings.

1.4 Technical Documentation

1.4.1 Classification Documentation of Ship under Construction

Prior to beginning the construction of the ship's hull, the documentation specified in 1.4.2 shall be submitted to the PRS Head Office for consideration and approval within the applicable scope, taking into account the ship type, its equipment and outfitting. PRS may extend the scope of classification documentation, specified below if it is considered necessary upon examination of the ship technical specification and general arrangement plan.

1.4.2 Hull Documentation

- .1** Data on the longitudinal, zone and local strength:
 - basic theoretical data: body lines, hydrostatic curves,
 - mass of light ship and its longitudinal distribution,
 - intended load conditions and mass distribution of cargo and provisions,
 - calculation of maximum still water bending moments and shear forces,
 - minimum and maximum draught of ship in service and corresponding trim,
 - load on deck, hatch covers and inner bottom if different from those given in the *Rules*,
 - type, density and angle of repose of dry bulk cargo,
 - maximum density of liquid cargo intended to be carried in tanks,
 - heights of air pipes, measured from the tank tops or from the decks above which these pipes are carried,
 - mass of heavy machinery components,
 - other local loads or forces which will affect the hull structure,
 - description of the assumed changes of the ship ballasting on a voyage and the description of consequential limitations due to weather conditions.
- .2** Midship section with characteristic cross-sections, including main dimensions of ship, full requested symbol of class, equipment number and other data such as speed, number of crew and passengers.
- .3** Longitudinal section with specified frame spacings, location of watertight bulkheads, pillars, superstructures and deckhouses.
- .4** Shell expansion, including arrangement of primary supporting members, stiffeners, bulkheads, decks and platforms, as well as the arrangement and scantlings of shell

openings; the extent of bottom flat portion of ship fore part shall be indicated in the drawing.

- .5** Drawings of decks and platforms, including the arrangement and dimensions of the openings.
- .6** Drawing of the double bottom.
- .7** Drawings of longitudinal and transverse bulkheads, as well as the tank bulkheads, including the height of tank overflow and air pipes.
- .8** Drawings of machinery spaces, including foundations of main engines and boilers, as well as the bottom structure under the foundations, tanks, pillars, strengthenings, e.g. for upper fastening of the engine; type and rating of the engine shall be given, and the guidelines of the engine manufacturer concerning the foundation shall be taken into account; the height of tank overflow pipes and air pipes shall be specified.
- .9** Drawings of aft portion and stern indicating the distance from the propeller to stern and rudder.
- .10** Drawings of forward portion and stem.
- .11** Drawings of supports and exits of propeller shafts, suspension of rudder and fixed propeller nozzles.
- .12** Drawings of superstructures and deckhouses.
- .13** Technological documentation:
 - table of hull welding unless all data and dimensions concerning the welding are specified in the design drawings.
- .14** Ballast tanks' painting plan.

In addition, the following technical documentation shall be submitted:

- .15** For ro-ro ships:
 - plan of the arrangement and securing of the carried vehicles, including the maximum axle load and forces in sockets and lashing eyes of the vehicle securing equipment,
 - type and data on vehicles used for ro-ro handling, including the axle loads, detailed data on wheels and their print.
- .16** For container ships:
 - arrangement plan of containers, including the data on their maximum mass and strength standard,
 - securing plan of containers, including sockets, stays and supports,
 - drawings of supporting structures, including cell guide structures and adjacent structures of hull, as well as container sockets and other support with necessary reinforcements of hull structure,
 - calculations of maximum forces and stresses in container supports, in adjoining hull structures, cell guides, lashing, etc.
- .17** For dredgers:
 - arrangement plan of dredging equipment and systems,
 - drawing of supporting structures and hull strengthenings.
- .18** For floating cranes:
 - plan showing location of the lifting appliance during operation and in parked position, including specification of forces transmitted to the hull structure,
 - plan of crane device fastening to the hull in the stowed condition,
 - drawings of supporting structures and hull strengthenings in way of supports,
 - assembly plan showing principal dimensions of the crane and terminal positions of its movable parts,
 - calculations for determining hull girder scantlings, including information on loads which may affect the material fatigue strength.
- .19** For ships mooring to other ships at sea:
 - data on means attenuating hull impacts.

- .20** For energy efficient ships, the scope of documentation and its approval procedure are described in 28.1.2.
- .21** For ships (also pontoons, barges) carrying onboard non-typical cargo posing potential problems (requirements of CSS Code):
- loading condition and definition of the unit stability;
 - plan of the arrangement, seating and securing of cargo, specifying cargo dimensions, windage area, gravity centre mass and position, situation of the cargo itself and of fixing arrangements onboard the pontoon, calculations of accelerations acc. to chapter 17 and of forces and moments acting on cargo;
 - cargo securing plan specifying the method and selection of securing fittings, information on minimum breaking load, MSL (Maximum Securing Load) and maximum reactions acting on the securing fittings and in the securing arrangements;
 - design drawings of structure strengthenings in way of cargo seating and securing, together with strength calculations.

1.4.3 Classification Documentation of Ship under Alteration

Prior to beginning the ship alteration, the documentation of ship parts to be altered shall be submitted to the PRS Head Office for consideration and approval.

1.4.4 Workshop Documentation of Ship

Upon approval of classification documentation by the PRS Head Office, the following workshop documentation shall be submitted to the relevant PRS Branch Office or Survey Station for consideration and agreement:

- diagram of hull subdivision into sections and blocks, as well as the plan of assembling sequence,
- plan of non-destructive tests of welded joints,
- plan of hull tightness tests,
- drawings showing passage of pipelines, ventilation ducts and cables through the hull plating, bottom, decks, bulkheads, primary supporting members, etc.,
- drawings of local strengthenings under gear and machinery not shown in classification documentation,
- specification, drawings and test programme for innovatory engineering processes, solutions of structural nodes and applied materials,
- programme of mooring and sea trials.

1.4.5 Documentation on Board

1.4.5.1 Complete set of as-built construction drawings and plans showing any subsequent structural alterations shall be kept on board a ship for the lifetime of the ship.

An additional set of documentation shall be available also in the Owner's offices (see also *SOLAS II-1*, Regulation 3-7).

1.4.5.2 All oil tankers of 5,000 tons deadweight and above shall have ready access to shore-based computer programs for calculation of stability and structure strength in damaged condition (see *MARPOL*, Annex I, Regulation 37).

1.4.6 Ship Identification Number

Documents which a ship is necessary to be provided with in accordance with the requirements contained in IMO Conventions shall be marked with an identification number which conforms to the Identification Number Scheme adopted by IMO (see also *SOLAS XI-I*, Regulation 3).

1.5 Ergonomic Considerations

1.5.1 Hull shape, the framing system of hull and superstructures, the scantlings of supporting members and stiffeners, and applied damping coverings shall be selected in such a way that the safety of personnel onboard and proper health-related conditions are ensured, as well as the comfort and effectiveness of their work, taking into account possible exposure to vibration and noise, possibility to enter/leave ship's spaces and the operational conditions of equipment.

1.5.2 Detailed recommendations in this domain and applicable standards are given in IACS *Recommendation No. 132 Human Element Recommendations for structural design of lighting, ventilation, vibration, noise, access & egress arrangements*.

2 MATERIALS AND PROTECTION AGAINST CORROSION

2.1 General

Materials intended for structures covered by the present Part of the *Rules* shall comply with the requirements specified in *Part IX – Materials and Welding*. Additional requirements concerning gas carriers are given in *Publication 48/P – Requirements Concerning Gas Tankers*.

2.2 Hull Structural Steels

2.2.1 Normal and Higher Strength Hull Structural Steel

2.2.1.1 Normal strength structural steel NS and higher strength structural steels HS 32, HS 36 and HS 40 shall be used in the construction of the ship's hull.

2.2.1.2 Hull structural steel notations, division into grades (in accordance with Tables 3.6.2-1 and 3.6.2-2 of *Part IX – Materials and Welding*), as well as the minimum values of yield point R_e and the corresponding values of material factors k are specified in Table 2.2.1.2.

Table 2.2.1.2

Notation	Steel grade				R_e [MPa]	k
	A	B	D	E		
NS	A	B	D	E	235	1.00
HS32	AH32	-	DH32	EH32	315	1.28
HS36	AH36	-	DH36	EH36	355	1.39
HS40	AH40	-	DH40	EH40	390	1.47 / 1,52 ^(*)

(*) 1,52 for steel with $R_e = 390$ N/mm² provided that a fatigue assessment of the structure is performed to verify compliance with the requirements of the Society

2.2.1.3 Materials in the strength members not subject to the effect of low temperatures (see paragraph 2.2.1.4) shall not be of lower grade than those specified in Tables 2.2.1.3-1 to 2.2.1.3-6.

General requirements are given in Table 2.2.1.3-1. Additional minimum requirements for ships with length exceeding 150 m or 250 m, bulk carriers which are subject to the requirements of *SOLAS – XII/6.4.3*, as well as ice strengthened ships are specified in Tables 2.2.1.3-2 to 2.2.1.3-5.

The requirements concerning material grades for hull structural members depending on the hull member class and thickness are specified in Table 2.2.1.3-6.

Table 2.2.1.3-1
Application of Material Classes and Grades

Structural member category	Material class
<p>SECONDARY:</p> <p>A1. Longitudinal bulkhead strakes, other than that belonging to the Primary category</p> <p>A2. Deck plating exposed to weather, other than that belonging to the Primary or Special category</p> <p>A3. Side plating</p>	<ul style="list-style-type: none"> - Class I within 0.4L amidships - Grade A/AH outside 0.4L amidships
<p>PRIMARY:</p> <p>B1. Bottom plating, including keel plate</p> <p>B2. Strength deck plating, excluding that belonging to the Special category</p>	<ul style="list-style-type: none"> - Class II within 0.4L amidships - Grade A/AH outside 0.4L amidships

Structural member category	Material class
B3. Continuous longitudinal plating of strength members above strength deck, excluding hatch coamings (for ships with length $L_0 \geq 90$ m) B4. Uppermost strake in longitudinal bulkhead B5. Vertical strake (hatch side girder) and uppermost sloped strake in top wing tank	
SPECIAL: C1. Sheer strake at strength deck (*) C2. Stringer plate in strength deck (*) C3. Deck strake at longitudinal bulkhead (excluding deck plating in way of inner-skin bulkhead in double-hull ships) (*)	- Class III within 0.4L amidships - Class II outside 0.4L amidships - Class I outside 0.6L amidships
C4. Strength deck plating at outboard corners of cargo hatch openings in container carriers and other ships with similar hatch opening configurations	- Class III throughout the cargo region; outside the cargo region, the required categories of structural members shall be determined as in items C1 ÷ C3
C5. Strength deck plating at corners of cargo hatch openings in bulk carriers, ore carriers, combination carriers and other ships with similar hatch opening configurations	- Class III within 0.6L amidships - Class II within the rest of cargo region
C6. Bilge strake in ships with double bottom over the full breadth and length less than 150 m (*)	- Class II within 0.6L amidships - Class I outside 0.6L amidships
C7. Bilge strake in ships other than those specified in C6 (*)	- Class III within 0.4L amidships - Class II outside 0.4L amidships - Class I outside 0.6L amidships
C8. Longitudinal hatch coamings of length greater than $0.15L_0$, including coaming top plate and flange C9. End brackets of cargo hatch coamings or deck house transition of continuous longitudinal cargo hatch coamings	- Class III within 0.4L amidships - Class II outside 0.4L amidships - Class I outside 0.6L amidships - Not less than D/DH

(*) Single strakes required to be of class III within 0.4L amidships shall have breadth not less than $800 + 5L_0$, [mm] (need not, however, be greater than 1800 mm) – unless limited by the geometry of the ship's design.

Table 2.2.1.3-2
Minimum grades of steel for ships with length exceeding 150 m
with one continuous strength deck

Structural member category	Steel grade
Longitudinal plating of strength deck where contributing to the longitudinal strength Continuous longitudinal members above strength deck	Grade B/AH within 0.4L amidships
Single side strakes for ships without inner continuous longitudinal bulkhead(s) between the bottom and strength deck	Grade B/AH within the cargo region

Table 2.2.1.3-3
Minimum grades of steel for ships with length exceeding 250 m

Structural member category	Steel grade
Sheer strake at the strength deck (*)	Grade E/EH within 0.4L amidships
Stringer plate in strength deck (*)	Grade E/EH within 0.4L amidships
Bilge strake (*)	Grade D/DH within 0.4L amidships

(*) Single strakes required to be of grade D/DH or grade E/EH as shown in the above table and within 0.4L amidships shall have breadth not less than $800 + 5L$, [mm] (need not, however, be greater than 1800 mm) – unless limited by the geometry of the ship's design.

Table 2.2.1.3-4
Minimum grades of steel for single-side skin bulk carriers which are subject to requirements of SOLAS–XII/6.4

Structural member category	Steel grade
Lower brackets of ordinary side frames (*) (**)	Grade D/DH
Side shell strakes included totally or partially between the two points located to $0.125 h$ above and below the intersection of side shell and bilge hopper sloping plate or inner bottom plate (**)	Grade D/DH

(*) The term "lower bracket" means webs of lower brackets and webs of the lower part of side frames up to the point of $0.125h$ above the intersection of side shell and bilge hopper sloping plate or inner bottom plate.

(**) Side frame span h is defined as the distance between the structures supporting the frame (see h in Fig. 20.5.4-1).

Table 2.2.1.3-5
Minimum steel grades for ships with ice strengthening

Structural member category	Steel grade
Shell strakes in way of ice strengthening area for plates	Grade B/AH

For structural members not specified in Tables 2.2.1.3-1 to 2.2.1.3-5, steel grades A/AH may be used generally. The steel grade shall correspond to the actual plate thickness (if it is greater than that required in the present Part of the *Rules*) and material class.

Table 2.2.1.3-6
Material grade requirements for classes I, II and III

Class	I		II		III	
	NS	HS	NS	HS	NS	HS
Member thickness [mm]						
$t \leq 15$	A	AH	A	AH	A	AH
$15 < t \leq 20$	A	AH	A	AH	B	AH
$20 < t \leq 25$	A	AH	B	AH	D	DH
$25 < t \leq 30$	A	AH	D	DH	D	DH
$30 < t \leq 35$	B	AH	D	DH	E	EH
$35 < t \leq 40$	B	AH	D	DH	E	EH
$40 < t \leq 50$	D	DH	E	EH	E	EH

Plating materials for sternframes, rudders, rudder horns and shaft brackets shall, in general, not be of lower grades than corresponding to class II. For rudder and rudder body plates subjected to stress concentrations (e.g. in way of lower support of semi-spade rudders or at upper part of spade rudders), class III shall be applied.

2.2.1.4 For ships intended to operate in areas with low air temperatures (below -10°C), e.g. regular service during winter seasons in the Arctic or Antarctic waters, the materials in exposed structures shall be selected based on the design temperature t_p , to be taken as defined in 2.2.4.

Materials in various strength members above the lowest ballast water line (BWL) exposed to air (including the structural members covered by the Note 5 of Table 2.2.1.4-1) and materials of cargo tank boundary plating for which sub-chapter 2.2.5 is applicable shall not be of lower grades than those corresponding to classes I, II and III, depending on the categories of structural members (Secondary, Primary and Special) as given in Table 2.2.1.4-1.

Table 2.2.1.4-1**Application of material classes and grades for structures exposed at low temperatures**

Structural member category	Material class	
	Within 0.4L amidships	Outside 0.4L amidships
SECONDARY: Deck plating exposed to weather, in general Side plating above BWL Transverse bulkheads above BWL ⁵⁾ Cargo tank boundary plating exposed to cold cargo ⁶⁾	I	I
PRIMARY: Strength deck plating ¹⁾ Continuous longitudinal members above strength deck, excluding longitudinal hatch coamings Longitudinal bulkhead above BWL ⁵⁾ Top wing tank bulkhead above BWL ⁵⁾	II	I
SPECIAL: Shear strake at strength deck ²⁾ Stringer plate in strength deck ²⁾ Deck strake at longitudinal bulkhead ³⁾ Continuous longitudinal hatch coaming ⁴⁾	III	II

1) Plating at corners of large hatch openings to be specially considered. Class III or Grade E/EH to be applied in positions where high local stresses may occur.

2) Steel grade not to be less than Grade E/EH within 0,4L amidships in ships with length $L > 250$ m.

3) In ships with breadth $B > 70$ m at least three deck strakes to be Class III.

4) Steel grade not to be less than Grade D/DH.

5) Applicable to plating attached to hull envelope plating exposed to low air temperature. At least one strake is to be considered in the same way as exposed plating and the strake width is to be at least 600 mm.

6) For cargo tank boundary plating exposed to cold cargo for ships other than liquefied gas carriers, see sub-chapter 2.2.5.

For non-exposed structures (except as indicated in Note 5) of Table 2.2.1.4-1 and structures below the lowest ballast water line, Tables 2.2.1.3-1 to 2.2.1.3-6 apply.

Material grade requirements for hull members of each class depending on thickness and design temperature are specified in Table 2.2.1.4-2. For design temperatures $t_p < -55$ °C, materials are subject to PRS consideration in each particular case.

Single strakes required to be of class III or of grade E/EH or FH shall have breadths not less than $800 + 5L_0$ mm, however, the breadths need not be greater than 1800 mm.

Plating materials for sternframes, rudder horns, rudders and shaft brackets shall not be of lower grades than those specified in paragraph 2.2.1.3.

Table 2.2.1.4-2**Material grade requirements for classes I, II and III at low temperatures****Class I**

Plate thickness [mm]	-11/-15°C		-16/-25°C		-26/-35°C		-36/-45°C		-46/-55°C	
	NS	HS	NS	HS	NS	HS	NS	HS	NS	HS
$t \leq 10$	A	AH	A	AH	B	AH	D	DH	D	DH
$10 < t \leq 15$	A	AH	B	AH	D	DH	D	DH	D	DH
$15 < t \leq 20$	A	AH	B	AH	D	DH	D	DH	E	EH
$20 < t \leq 25$	B	AH	D	DH	D	DH	D	DH	E	EH

Plate thickness [mm]	-11/-15°C		-16/-25°C		-26/-35°C		-36/-45°C		-46/-55°C	
	NS	HS	NS	HS	NS	HS	NS	HS	NS	HS
$25 < t \leq 30$	B	AH	D	DH	D	DH	E	EH	E	EH
$30 < t \leq 35$	D	DH	D	DH	D	DH	E	EH	E	EH
$35 < t \leq 45$	D	DH	D	DH	E	EH	E	EH	∅	FH
$45 < t \leq 50$	D	DH	E	EH	E	EH	∅	FH	∅	FH

∅ = Not applicable

Class II

Plate thickness, [mm]	-11/-15°C		-16/-25°C		-26/-35°C		-36/-45°C		-46/-55°C	
	NS	HS	NS	HS	NS	HS	NS	HS	NS	HS
$t \leq 10$	A	AH	B	AH	D	DH	D	DH	E	EH
$10 < t \leq 20$	B	AH	D	DH	D	DH	E	EH	E	EH
$20 < t \leq 30$	D	DH	D	DH	E	EH	E	EH	∅	FH
$30 < t \leq 40$	D	DH	E	EH	E	EH	∅	FH	∅	FH
$40 < t \leq 45$	E	EH	E	EH	∅	FH	∅	FH	∅	∅
$45 < t \leq 50$	E	EH	E	EH	∅	FH	∅	FH	∅	∅

∅ = Not applicable

Class III

Plate thickness [mm]	-11/-15°C		-16/-25°C		-26/-35°C		-36/-45°C		-46/-55°C	
	NS	HS	NS	HS	NS	HS	NS	HS	NS	HS
$t \leq 10$	B	AH	D	DH	D	DH	E	EH	E	EH
$10 < t \leq 20$	D	DH	D	DH	E	EH	E	EH	∅	FH
$20 < t \leq 25$	D	DH	E	EH	E	EH	E	FH	∅	FH
$25 < t \leq 30$	D	DH	E	EH	E	EH	∅	FH	∅	FH
$30 < t \leq 35$	E	EH	E	EH	∅	FH	∅	FH	∅	∅
$35 < t \leq 40$	E	EH	E	EH	∅	FH	∅	FH	∅	∅
$40 < t \leq 50$	E	EH	∅	FH	∅	FH	∅	∅	∅	∅

∅ = Not applicable

2.2.2 Steel with Specified Through Thickness Properties

2.2.2.1 Where a plate type structural element of the thickness 15 mm and more is exposed to considerable tensile stress perpendicular to its plane and no solution preventing delamination has been provided, this element shall be made of steel "Z".

2.2.2.2 Steel for plates of the thickness 15 mm and more, subjected to tensile load perpendicular to their surface, shall comply with the requirements for steel "Z" specified in Chapter 5, *Part IX – Materials and Welding*.

Unless otherwise agreed with PRS, these plates shall be made of E, EH or FH steel grades.

2.2.3 Clad Steel

Where clad steel is used, its mechanical properties shall not be worse than those required for steel grades specified in Tables 2.2.1.3-1 to 2.2.1.3-6. Hull structural steel shall be considered as the base material.

2.2.4 Design Temperature of Structures

2.2.4.1 As the design temperature, t_p , the lowest mean daily average air temperature in the area of operation shall be taken.

Mean: Statistical mean over observation period (at least 20 years).

Average: Average during one day and night.

Lowest: Lowest during year.

For seasonally restricted service, the lowest value within the period of operation applies.

For the purpose of issuing a Polar Ship Certificate in accordance with the Polar Code, the design temperature t_D shall be no more than 13°C higher than the Polar Service Temperature (PST) of the ship. In the Polar Regions, the statistical mean observation period is to be determined for a period of least 10 years.

Fig. 2.2.4.1 illustrates the temperature definition.

Commonly used definitions of temperatures:

MDHT = Mean Daily High (or maximum) Temperature

MDAT = Mean Daily Average Temperature.

MDLT = Mean Daily Low (or minimum) Temperature.

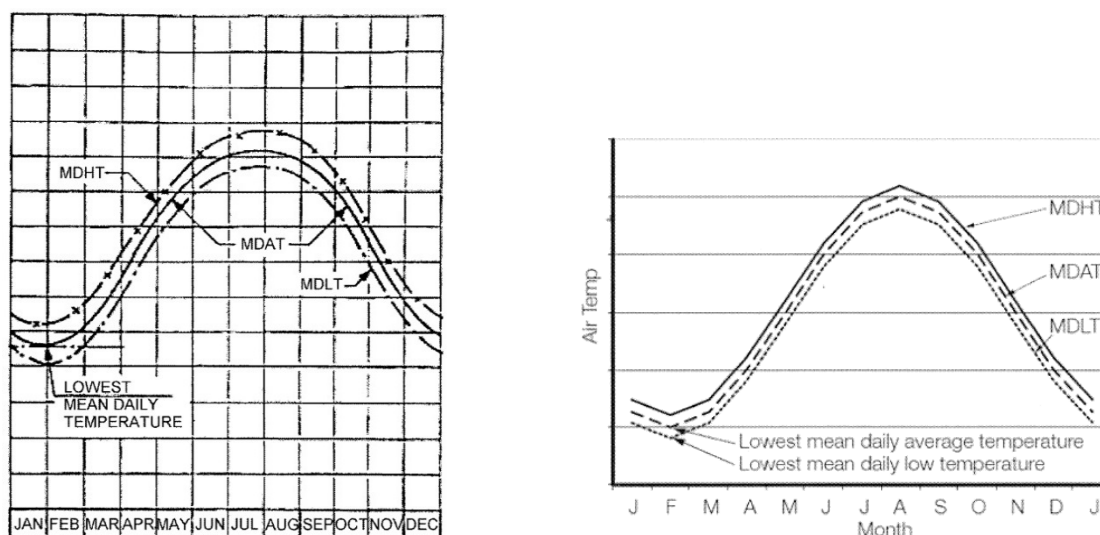

Fig. 2.2.4.1

2.2.4.2 For ships with **L1A** or **L1** ice strengthening mark in the symbol of class, the assumed value of temperature t_p shall not be greater than -20°C .

2.2.4.3 The design temperature of structures located inside refrigerated spaces shall be taken equal to the lowest air temperature t_a inside the spaces.

2.2.4.4 The design temperature of structures forming boundaries of refrigerated spaces shall be equal to:

- the lowest temperature in the refrigerated space if the structure has not been covered with insulation on the side of this space,
- the lowest temperature of the adjacent space if the structure has been covered with insulation in the refrigerated space and has not been insulated on the other side,
- the mean lowest temperature of the adjacent spaces if the structure has been covered with insulation on both sides.

2.2.4.5 In justified cases, the values of design temperatures may be increased.

2.2.5 Cold cargo for ships other than liquefied gas carriers

2.2.5.1 In justified cases, the values of design temperatures may be increased. For ships other than liquefied gas carriers, intended to be loaded with liquid cargo having a temperature below -10°C, e.g. loading from cold onshore storage tanks during winter conditions, the material grade of cargo tank boundary plating is defined in Table 2.2.1.4-2 based on the following:

- t_c design minimum cargo temperature in °C,
- steel grade corresponding to Class I as given in Table 2.2.1.4-1.

The design minimum cargo temperature, t_c is to be specified in the loading manual.

2.3 Other Structural Materials

2.3.1 Aluminium Alloys

2.3.1.1 Aluminium alloys of grade specified in Chapter 18, *Part IX – Materials and Welding* may be applied to construction of:

- hull structure of length $L_0 < 40$ m,
- superstructures and deckhouses.

2.3.1.2 Strength of aluminium structure shall not be worse than that required for steel structures.

2.3.1.3 Material factor k for aluminium alloys shall be determined in accordance with the formula:

$$k = \frac{R_e}{235} \quad (2.3.1.3)$$

where R_e value, characteristic of soft (recrystallized or hot rolled) condition of the aluminium alloy, shall not be taken greater than $0.7R_m$ (R_m – tensile strength).

Where aluminium alloys delivered in semi-hard or quarter-hard condition shall be used for welded structures, yield stress is subject to PRS acceptance in each particular case.

2.3.2 Alternative Materials

The application of alternative materials for ship structure is subject to PRS consideration in each particular case.

2.4 Corrosion Protection

2.4.1 All dedicated seawater ballast tanks on all types of ships and double-side skin spaces arranged in bulk carriers of 150 m in length and above shall be coated during construction with protective coating complying with the *SOLAS II-1*, Regulation 3-2 (detailed requirements are

contained in resolution MSC.215(82)) and the requirements of *Publication 55/P – Survey of Corrosion Protection and Anti-fouling Systems*).

The above requirements apply to ships of not less than 500 gross tonnage.

The following tanks are not considered to be dedicated seawater ballast tanks and are therefore exempt from the application of the above-mentioned requirements:

- ballast tanks identified as “Spaces included in Net Tonnage” in the 1969 *ITC Certificate*;
- seawater ballast tanks in passenger ships also designated for the carriage of grey water;
- seawater ballast tanks in livestock carriers also designated for the carriage of animals’ dung.

2.4.2 Oil tankers and bulk carriers not mentioned in 2.4.1 shall have all dedicated ballast tanks coated with appropriate protective coating – hard or equivalent, laid in accordance with the manufacturer’s instructions. It is recommended that the coating should be of light colour (see *SOLAS II-1*, Regulation 3-2, in revision complying with resolution MSC.47(66)).

Where appropriate, sacrificial anodes shall also be used.

Double-side skin spaces arranged in bulk carriers of 150 m in length and above, not mentioned in 2.4.1, shall be coated during construction in accordance with the requirements specified in *SOLAS II-1*, Regulation 3-2, in revision complying with resolution MSC.47(66).

2.4.3 In the case of newly-built bulk carriers, all internal and external surfaces of hatch coamings and hatch covers and all internal surfaces of holds, excluding flat surfaces of internal bottom plating and slope plating of bilge tanks up to the height of about 300 mm below side frames and brackets, shall have appropriate protective coating – hard or equivalent, laid in accordance with the manufacturer’s instructions.

When choosing the type of coating, foreseeable service conditions (such as kind of the carried cargo) shall be taken into account.

2.4.4 At the Owner’s request, upon individual consideration by PRS, the corrosion additions, as required in 2.5, may be reduced or completely neglected, provided an efficient hull structure corrosion protection method is applied. In such case the ship may be assigned an additional mark **PAC** in the symbol of class.

2.4.5 In tanks used for water ballast or liquid cargo (crude oil and its products) and in holds, thicknesses of structural elements shall be increased by corrosion additions specified in 2.5 (see also 20.1.6).

2.4.6 The requirements for anti-corrosion protective coatings and cathodic protection are specified in *Publication 55/P – Survey of Corrosion Protection and Anti-fouling Systems*.

2.4.7 All cargo oil tanks of new crude oil tankers¹ shall be:

- .1 coated during the construction of the ship in accordance with the Performance Standard for protective coatings for cargo oil tanks of crude oil tankers described in *Resolution MSC.288 (87), as amended*, adopted by IMO. This standard shall be interpreted according to IACS *UI SC259*; or
- .2 protected by alternative means of corrosion protection or utilization of corrosion resistance material to maintain required structural integrity for 25 years in accordance with the Performance Standard for alternative means of corrosion protection for cargo oil

¹ Crude oil tanker as defined in regulation 1 of Annex I MARPOL 73/78, of deadweight of not less than 5000 tons. This paragraph does not apply to combination carriers (including chemical carriers certified to carry oil).

tanks of crude oil tankers described in *Resolution MSC.289(87)* published by IMO. This standard shall be interpreted according to IACS *UI SC258*.

2.4.8 The Administration may exempt a crude oil tanker from the requirements of paragraph 2.4.7 to allow the use of novel prototype alternatives to the coating system specified in 2.4.7.1, for testing, provided they are subject to suitable controls, regular assessment and acknowledgement of the need for immediate remedial action if the system fails or is shown to be failing. Such exemption shall be recorded on the exemption certificate.

2.4.9 The Administration may exempt a crude oil tanker from the requirements of paragraph 2.4.7 if the ship is built to be engaged solely in the carriage of cargoes and cargo handling operations not causing corrosion. Such exemption and conditions for which it is granted shall be recorded on an exemption certificate.

2.4.10 Detailed requirements for Performance Standards are given in paragraphs 21.3.8 and 21.3.9.

2.5 Corrosion Additions

2.5.1 Paragraphs 2.5.2 to 2.5.5 apply to structural members of steel hulls. For structures made of aluminium alloys, corrosion additions are not required.

2.5.2 The thickness of the plating of vertical and horizontal bulkheads forming boundaries of the tanks, mentioned in 2.4.5, shall be increased by corrosion addition t_k determined in accordance with the formula:

$$t_k = t_w + t_z \text{ [mm]} \quad (2.5.2)$$

t_w – corrosion addition determined in accordance with 2.5.6 for the inner side of plating, according to the type of liquid carried in the tank, [mm];

t_z – corrosion addition determined in accordance with 2.5.6 for the outer side of the plating, according to the designation of the adjacent space, [mm].

2.5.3 The thickness of face plates, webs and brackets of stiffeners and primary supporting members, situated inside the tanks mentioned in 2.4.5, shall be increased by corrosion addition t_k determined in accordance with the formula:

$$t_k = 2 t_w \text{ [mm]} \quad (2.5.3-1)$$

Where stiffeners or primary supporting members of the tank bulkhead are at its outer side, the corrosion addition t_k shall be determined in accordance with the formula:

$$t_k = 2 t_z \text{ [mm]} \quad (2.5.3-2)$$

t_w and t_z – as in 2.5.2.

2.5.4 For horizontal webs or face plates of stiffeners or primary supporting members, the corrosion addition shall be additionally increased by 0.5 mm.

2.5.5 Corrosion additions t_w and t_z depend on area (A, B) of the tank or cargo hold in which the considered structural element is installed, as well as on the type of the agent acting on the considered side of the structural element in question.

Where the upper side of tank or cargo hold is closed by the weather deck, then A area of this tank or cargo hold is the area extending vertically from the weather deck to the level 1.5 m below this deck. All other areas of tanks and cargo holds are B areas.

2.5.6 Depending on the type of agent acting on the considered side of the structural element, corrosion additions t_w or t_z for A area are as follows:

- 1.5 mm – for water ballast,
- 1.0 mm – for oil,
- 0.5 mm – for dry cargo,
- 0.0 mm – for (external) outboard water or air.

Corrosion additions t_w or t_z for B area are equal to half of the values provided for A area.

2.6 Anti-fouling systems

2.6.1 An anti-fouling system can be a coating system applied to exposed surfaces, biofouling¹ resistant materials used for piping and other unpainted components, marine growth prevention systems (MGPS) for sea-chests and internal seawater cooling systems or other innovative measures to control biofouling².

2.6.2 In the design and construction of a ship, or when a ship is being significantly altered, the following shall be taken into consideration:

- .1 exclusion – as far as practical – of small niches and sheltered areas from the ship. Where not practical, these shall be designed so that they may be easily accessed for inspection, cleaning and application of anti-fouling measures.
- .2 rounding and/or beveling of corners, gratings and protrusions to promote more effective coverage of anti-fouling coating systems, and hinging of gratings to enable diver access.
- .3 providing the capacity to blank off the sea chest and other areas, such as moon pools, floodable docks and other free flood spaces, for treatment and/or cleaning.

2.6.3 Internal seawater cooling systems shall be designed and made of appropriate material to minimize biofouling and constructed with a minimum of bends, kinks and flanges in seawater piping.

2.6.4 To avoid creation of avoidable niches³ while ensuring effective safety and operation of the ship, where practical, particular attention shall be given to avoidance of unfilled gaps in all skin fittings and the detailed design of the items as follows:

- .1 sea chests – it is recommended to minimize size and number, and use smooth surfaces to maximize flow efficiency, fit MGPS, and steam or hot water cleaning systems, grills and their opening arrangements designed for in-water inspection and maintenance;
- .2 retractable fittings and equipment – it is recommended to avoid external reinforcement (such as stiffeners) where possible, design for in-water inspection and maintenance;
- .3 tunnel thrusters – tunnels to be above lightship water line or accessible to divers, grills and their opening arrangements designed for in-water inspection, maintenance and operation;
- .4 sponsons and hull blisters – it is advisable to use them fully enclosed in preference to free flooding types, with access provisions made for in-water inspection, cleaning and maintenance;
- .5 stern tube seal assemblies and rope guards – it is recommended to design them for in-water inspection, cleaning and maintenance.

¹ Biofouling – accumulation of aquatic organisms on surfaces and structures immersed in or exposed to the aquatic environment.

² For details see *Publication 55/P – Survey of Corrosion Protection and Anti-fouling Systems*.

³ Areas on a ship that may be more susceptible to biofouling due to different hydro-dynamic forces, susceptibility to coating system wear or damage, or being inadequately, or not painted.

2.6.5 Consideration shall also be given to the need for tailored, differential installation of anti-fouling coating systems for different areas of the ship to match the required performance and longevity of the coating with the expected wear, abrasion and water flow rates in specific areas, such as the bow, rudder, or internal seawater cooling systems and sea chest interiors.

2.6.6 For sea chests, the following shall be considered when installing their anti-fouling systems:

- .1** inlet grates and the internal surfaces of sea chests shall be protected by an anti-fouling coating system that is suitable for the flow conditions of seawater over the grate and through the sea chest;
- .2** care shall be taken in surface preparation and application of any anti-fouling coating system to ensure adequate adhesion and coating thickness. Particular attention shall be paid to the corners and edges of sea chests, blowout pipes, holding brackets and the bars of grates.
- .3** the installation of MGPSs is encouraged to assist in treating the sea chest and internal seawater piping as part of the biofouling management plan. A careful evaluation of the consequential effects of MGPSs shall be made before installation, including potential effects on the ship and/or the environment and the existence of regulations affecting the use of MGPSs.

2.6.7 The following areas can also be particularly susceptible to biofouling growth:

- dry-docking support strips;
- edges and weld joints;
- rudder hinges and stabilizer fin apertures;
- propeller and shaft;
- cathodic protection anodes;
- Pitot tubes;
- sea inlet pipes and overboard discharges.

Special measures, compliant with *Publication 55/P – Survey of Corrosion Protection and Anti-fouling Systems*, shall be applied to protect these areas.

3 STRUCTURE PARTICULARS

3.1 General

The methods of determining the geometrical and strength parameters of the hull structure members, specified in the present Chapter, may be applied to the strength analysis of structural members unless stated otherwise in other Chapters of the present Part of the *Rules* or in *Publications*.

3.1.1 Rounding-off the Scantlings

3.1.1.1 The scantlings shall be rounded off to the nearest greater standard value. It is allowed to round off the plate thickness required for structural members to the nearest lower standard value within a margin of 0.25 mm.

3.1.1.2 When standard rolled sections are applied, it is allowed to round off the required values of section modulus, moment of inertia and cross-sectional area to the nearest lower standard value by not more, however, than 3% of the required value.

3.2 Modelling of Structural Members

3.2.1 Span of Primary Supporting Members and Stiffeners

3.2.1.1 Design span l of primary supporting members and stiffeners shall be determined as shown in Fig. 3.2.1.1.

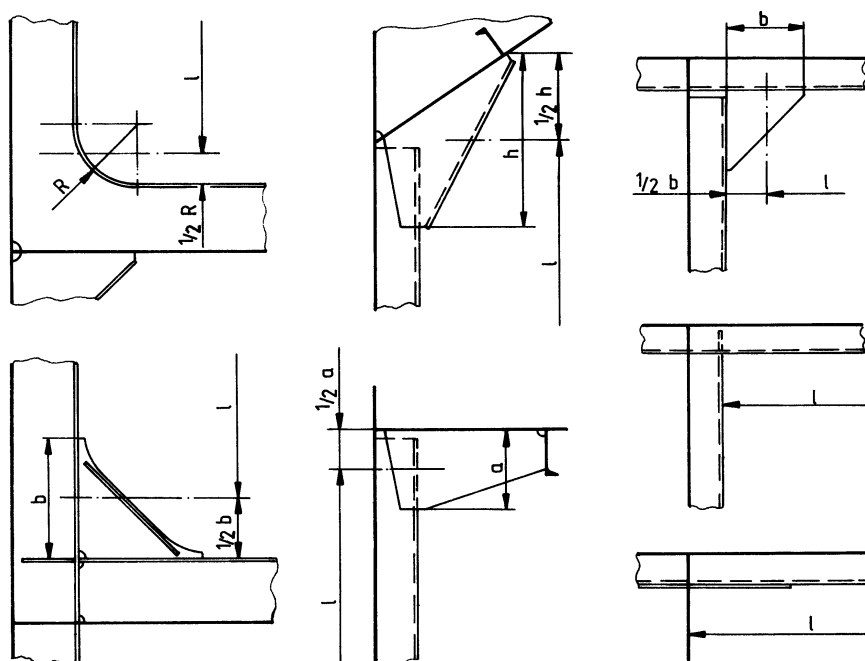

Fig. 3.2.1.1. Determining the span of structural members

It is assumed that brackets are effectively supported by the adjacent structure. In special cases, design span l may be determined in a different way. Design span l of curvilinear primary supporting members and stiffeners is measured as the length of chord between the supporting points.

3.2.2 Effective Flange

3.2.2.1 Cross-sectional area of the effective plate flange for stiffener or simple primary supporting member shall be determined in accordance with the following formula:

$$A_p = 10 b_e t \text{ [cm}^2\text{]} \quad (3.2.2.1)$$

t – mean thickness of the effective flange, [mm];

b_e – effective flange breadth, determined in accordance with 3.2.2.2 and 3.2.2.3, [m].

Continuous stiffeners, parallel to the web of primary supporting member in question and located within b_e width, may be included with 50% of their cross-sectional area in the effective plate flange area of the primary supporting member.

The effective plate flange area shall not be less than the sectional area of the free flange.

3.2.2.2 The effective flange width of stiffener may be taken equal to the lesser of the two values determined in accordance with the following formulae:

$$b_e = \frac{1}{6} l \text{ [m]} \quad (3.2.2.2-1)$$

$$b_e = 0.5(s_1 + s_2) \text{ [m]} \quad (3.2.2.2-2)$$

l – stiffener span, [m];

s_1, s_2 – distances from stiffener in question to the adjacent stiffeners fitted at its both sides, [m].

3.2.2.3 The effective flange width of simple primary supporting member shall be determined by the formula:

$$b_e = K b \text{ [m]} \quad (3.2.2.3)$$

$b = 0.5(b_1 + b_2)$, [m];

b_1, b_2 – distances from primary supporting member in question to the nearest primary supporting members of the same type fitted at its both sides, [m];

K – coefficient, taken from Table 3.2.2.3, depending on the span l_z of the primary supporting member, as well as on number n of evenly spaced perpendicular stiffeners supported by the primary supporting member in question;

$l_z = l$ – for primary supporting member simply supported at its both ends, [m],

$l_z = 0.6l$ – for primary supporting member fixed at its both ends, [m].

For intermediate values of l_z/b ratio and n number, coefficient K may be obtained by linear interpolation.

Table 3.2.2.3
Values of coefficient K

Number of stiffeners n	l_z/b ratio						
	1	2	3	4	5	6	7 and more
> 6	0.38	0.62	0.79	0.88	0.94	0.98	1
< 3	0.21	0.40	0.53	0.64	0.72	0.78	0.80

3.2.2.4 In the case of curved stiffeners face plates or primary supporting members, the effective sectional area A_e of the face plate shall be determined by the formula:

$$A_e = c \cdot b_m \cdot t_m \text{ [mm}^2\text{]} \quad (3.2.2.4-1)$$

where:

b_m – breadth of face plate, [mm],

t_m – thickness of face plate, [mm],

c – numerical coefficient determined by the formula (in formula 3.2.2.4-1, $c \leq 1$ shall be assumed):

$$c = c_1 \frac{\sqrt{r \cdot t_m}}{b} \quad (3.2.2.4-2)$$

r – radius of the face plate curvature, [mm];

$b = b_m$, [mm] – for asymmetrical face plates;

$b = 0.5(b_m - t_s)$, [mm] – for symmetrical face plates;

t_c – thickness of a web, [mm],

c_1 – coefficient having the values given in Table 3.2.2.4, depending on argument:

$$\beta = \frac{1.29 \cdot b}{\sqrt{r \cdot t_m}} \quad (3.2.2.4-3)$$

Note: Formula 3.2.2.4-1 shall also be applied when determining the effective section area of curved plating supported by the stiffener, assuming $b_m = s = b$ (s – stiffeners spacing) and $t_m = t$ (t – the thickness of plating).

Table 3.2.2.4
Values of coefficient c_1

β	0.2	0.25	0.3	0.4	0.45	0.5	0.6	0.7	0.8	0.9	1.0	1.2	1.4	≥ 1.6
c_1	3.21	2.57	2.14	1.84	1.61	1.43	1.29	1.08	0.94	0.83	0.76	0.70	0.60	0.59

Note: For the intermediate values of β , coefficient c_1 shall be determined by linear interpolation.

3.2.2.5 The effective sectional area A_e of curved face plates for primary supporting members supported by brackets welded to webs or the effective sectional area of curved plating supported by primary supporting members and stiffeners in direction transverse to primary supporting members (Fig. 3.2.2.5) shall be calculated by the formula:

$$A_e = \frac{3r t_m + c \cdot s^2}{3r t_m + s^2} \cdot t_m \cdot b_m \quad [\text{mm}^2] \quad (3.2.2.5)$$

where:

r, t_m, c – as in 3.2.2.4; when calculating the effective area A_e of the curved plating strake which constitutes the primary supporting member face plate in formula 3.2.2.5, $b_m = b_1$, $t_m = t$ shall be assumed (b_1, t – see Fig. 3.2.2.5);

s – spacing of stiffeners of the plating or brackets supporting the web, [mm], (Fig. 3.2.2.5).

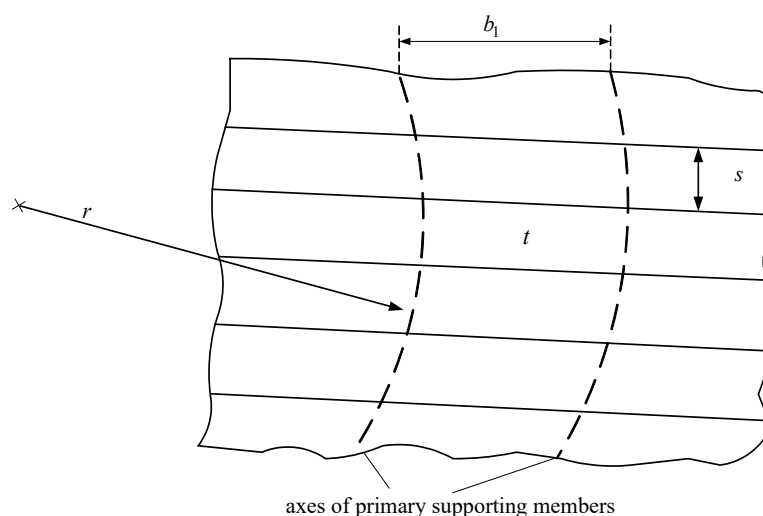

Fig. 3.2.2.5

3.2.2.6 The effective flange width b_e of corrugated bulkhead primary supporting members perpendicular to the corrugations shall be taken equal to $15 t$ – for trapezoidal corrugations and $20 t$ for undulated corrugations, respectively or $0.1b$ for both cases, whichever is the lesser.

" b " means the effective flange width, calculated in accordance with 3.2.2.3, whereas t means the corrugated bulkhead plating thickness.

3.2.2.7 The effective flange width b_e of hatchway coaming shall be taken equal to $1/12$ of its span. The assumed value of b_e shall not be greater than half the distance from the hatchway coaming to the ship's side for longitudinal coamings or half the distance between the coaming and the nearest transverse bulkhead for transverse coamings.

3.2.3 Effective Cross-sectional Area of Web

The effective cross-sectional area of the primary supporting members webs shall be determined by the formula:

$$A_s = 0.01 h_s t_s \text{ [cm}^2\text{]} \quad (3.2.3)$$

t_s – web thickness, [mm];

h_s – net web height, [mm].

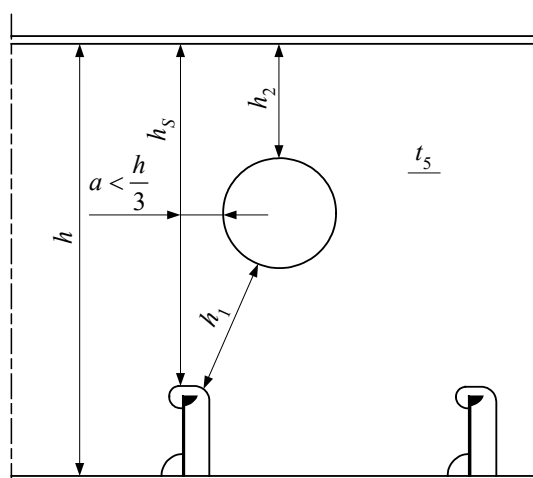

Fig. 3.2.3. Determining the net web height

The net web height h_s shall be determined by deduction of cut-outs and openings in the cross-section being considered. If the edge of the web opening is located at a distance less than $h/3$ from the cross-section considered, h_s shall be taken as the smaller of two values: h_s and $(h_1 + h_2)$, as shown in Fig. 3.2.3.

3.2.4 Section Moduli and Moments of Inertia of Stiffeners and Primary Supporting Members

Section moduli and moments of inertia of cross-sections of stiffeners and primary supporting members required by the present Part of the *Rules* refer to the neutral axis parallel to the plating.

Where the web of structural member is not perpendicular to the plating, the value of the section modulus about the axis parallel to the plating for $\alpha < 15^\circ$ (α – angle between the plane perpendicular to the plating and the web plane) may be determined approximately by multiplying the section modulus of the stiffeners perpendicular to the plating by $\cos \alpha$.

Unless otherwise stated, the effective flange taken for the calculation shall be determined in accordance with 3.2.2.

Note: The section modulus of corrugated bulkhead members may be calculated using the following approximate relations:

- for corrugated bulkhead member of trapezoidal cross-section and width equal to s_1 :

$$W = \frac{ht}{2} \left(s_2 + \frac{s_3}{3} \right) \text{ [cm}^3\text{]} \quad (3.2.4-1)$$

h, t – see Fig. 3.2.4 a), [mm];

s_2, s_3 – see Fig. 3.2.4 a), [m];

- for corrugated bulkhead member of undulated cross-section and width equal to s :

$$\begin{aligned} W &= c t r^2 \text{ [cm}^3\text{]} \\ s &= 4 r \sin \beta \\ c &= 2 \frac{\beta + 2\beta \cos^2 \beta - 1.5 \sin 2\beta}{1 - \cos \beta} \end{aligned} \quad (3.2.4-2)$$

t, r, s – see Fig. 3.2.4 b), [cm];

β – see Fig. 3.2.4 b), [rad].

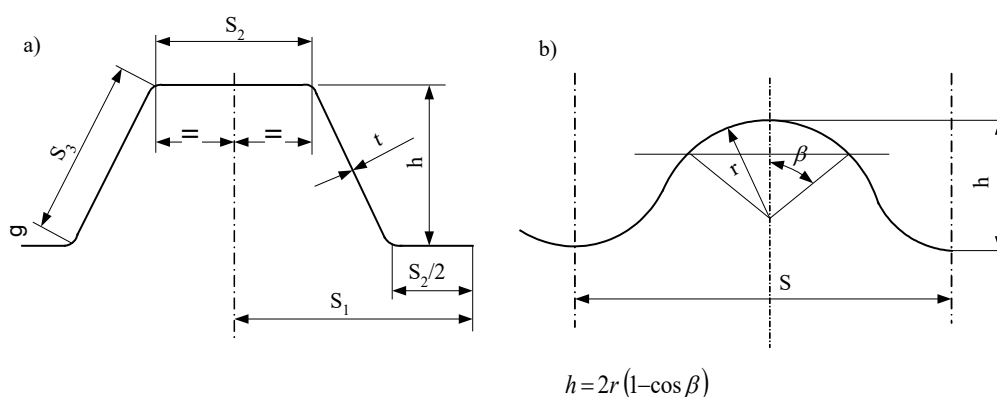

Fig. 3.2.4

3.3 Details of Welded Structures

3.3.1 Arrangement of Welded Joints

Local concentration of welds, crossing of welds at an acute angle, as well as close location of parallel butts or fillet welds and parallel butt welds shall be avoided. The distances between parallel welded joints, irrespective of their direction, shall not be less than:

- 200 mm between butt welds,
- 75 mm between a fillet weld and a butt weld,
- 50 mm between a fillet and a butt weld over a length not exceeding 2 m, except the cases specified below.

The angle between butt welds shall not be less than 60° (see Fig. 3.3.1).

The distance of joints (butts) of shell and deck plating panels from bulkheads, decks, inner bottom plating, primary supporting members, etc., arranged parallel to the joints, shall not be less than $5t$ (t – plate thickness) or 100 mm, whichever is the greater. For assembly joints (butts), this distance shall not be less than 200 mm.

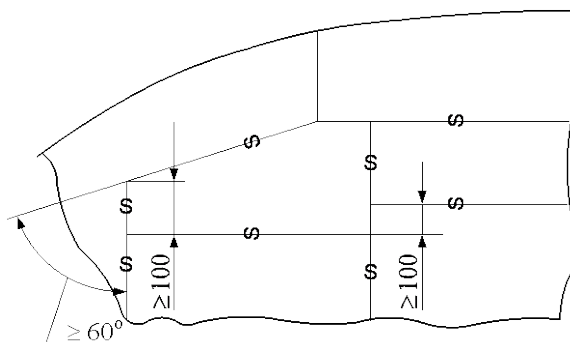

Fig. 3.3.1. Arrangement of welded joints

3.3.2 Joints of Face Plates

Face plate joints of crossing girders subjected to dynamic loads and primary supporting members of strength decks and single bottom amidships, as well as other highly loaded primary supporting members shall be made with smooth transition by means of diamond plates having the thickness not less than the thicknesses of primary supporting members face plates (see Fig. 3.3.2).

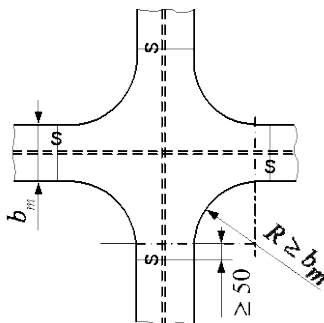

Fig. 3.3.2. Joints of primary supporting face plates

3.4 Structure Continuity

3.4.1 General Requirements

Structural continuity shall be maintained in the hull structure. Any changes in the shape of sections and in the member thickness shall be smooth.

3.4.2 Continuity of Longitudinal Members

3.4.2.1 Any changes in the scantlings of sections and in longitudinal member plate thickness along the hull shall be smooth. Arrangement and scantlings of members in the strength deck, bottom, sides and longitudinal bulkheads in areas of change of the strength properties of steel shall be kept unchanged.

3.4.2.2 The distance between the end of the stiffener and perpendicular, to the stiffener, web of primary supporting member or other stiffener shall be as small as practicable and shall not exceed $4t$ or 60 mm, whichever is the lesser (t – plating thickness, [mm]).

3.4.3 Connections

It is recommended that rounded brackets should be fitted where primary supporting members are connected to each other. The web of a primary supporting member shall be stiffened at the ends of brackets.

3.5 Openings in Structural Members

3.5.1 General Requirements

3.5.1.1 The total height of openings (lightening holes, single cut-outs in way of members, etc.) in one cross-section of a member shall not exceed 0.4 of its depth. In justified cases, this value may be increased in the centre of span to not more, however, than 0.6 of the member depth.

3.5.1.2 The distance between edges of all openings in primary supporting members and edges of single slots in way of stiffeners shall not be less than the depth of these stiffeners.

3.5.1.3 Holes in webs of stiffeners and primary supporting members shall not be arranged at a distance less than the web depth from the toe of end bracket.

3.5.1.4 Openings in member webs for free flow of liquid to the sucking terminals and for free flow of air to the air pipes shall be arranged inside the tanks. These openings shall be as close to the bottom and deck as practicable. It is recommended that openings in bottom and deck longitudinals should be elliptical and located at a distance not less than 20 mm from the bottom and deck plating. The height of the openings shall not be greater than 0.25 of the web height and shall not exceed 75 mm. The length of openings shall not exceed 150 mm.

3.5.1.5 Corners of any openings in members shall be rounded to a radius of curvature not less than twice the plate thickness.

3.5.1.6 Openings in side shell, longitudinal bulkheads and longitudinal primary supporting members shall be located below strength deck or termination of rounded deck corners at a distance not less than twice the opening breadth.

3.5.1.7 Small openings shall generally be kept well clear of other openings in longitudinal strength members. Unreinforced edges of small openings shall be located at a transverse distance not less than four times the opening breadth from the edge of any other opening.

3.5.1.8 Openings in longitudinals shall be of elliptical shape and shall be kept clear of the connecting welds on these longitudinals.

3.5.2 Edge Reinforcement of Openings in Bottom and Deck

3.5.2.1 The requirements specified below apply to openings in strength deck and outer bottom in the middle portion of the ship's hull within $-0.3L_0 < x < 0.3L_0$, and for ships with large hatchway openings within the total cargo hold region. The requirements concerning the shape and strengthening in way of hatch corners are given in 8.5.

3.5.2.2 Circular openings with diameter greater than 0.325 m shall have edge reinforcement. Cross-sectional area of edge reinforcements shall not be less than:

$$A_0 = 2.5dt \text{ [cm}^2\text{]} \quad (3.5.2.2)$$

d – diameter of opening, [m];

t – plate thickness, [mm].

3.5.2.3 Elliptical openings with breadth greater than 0.5 m shall have edge reinforcement if their length/breadth ratio is less than 2. The reinforcement shall be as required above for circular openings where d shall be taken equal to the opening breadth.

3.5.2.4 Rectangular or approximately rectangular openings shall have edge reinforcement in accordance with 3.5.2.2 where d shall be taken equal to the opening breadth. Corners of such openings shall comply with the following requirements:

– for corners of circular shape, the radius shall not be less than:

$$R = 0.2 b \text{ [m]} \quad (3.5.2.4)$$

b – breadth of opening, $b \geq 0.4$ m shall be taken;

– for corners of streamlined shape, the transverse extension of the curvature (perpendicular to ship centre plane) shall not be less than $0.15b$.

3.6 Construction of T-Section Primary Supporting Members

3.6.1 General Requirements

3.6.1.1 The requirements specified in the present sub-chapter apply to primary supporting members made as T-sections or I-sections.

3.6.1.2 The depth h and thickness t_s of primary supporting member webs (as well as of transverse frames and longitudinal stiffeners welded of separate webs and face plates), as well as their cross-sectional areas are covered by the requirements specified in the relevant Chapters of the present Part of the *Rules*.

3.6.1.3 Primary supporting member web plate and flange shall be stiffened by tripping brackets in accordance with 3.6.4. Stiffeners parallel or perpendicular to the flanges may also be required, in accordance with 3.6.3, unless otherwise stated in other Parts of the *Rules*.

3.6.2 Primary Supporting Member Flanges

3.6.2.1 Unsupported breadth of primary supporting member flange b , measured from the web, shall not be greater than:

$$b = \frac{200t_m}{\sqrt{R_e}} c \text{ [mm]} \quad (3.6.2.1)$$

t_m – flange thickness, [mm];

c – 1.0 for steel;

c – 0.58 for aluminium alloys.

3.6.2.2 Flange thickness shall not exceed the triple thickness of the web.

3.6.3 Primary Supporting Member Stiffeners

3.6.3.1 Primary supporting member webs shall comply with the buckling strength criteria specified in paragraph 13.6.4.2. Where the ratio of primary supporting member web height h to its thickness t_s is greater than $c890/\sqrt{R_e}$ ($c = 1.0$ for steel; $c = 0.58$ for aluminium alloys), then the primary supporting member web shall be stiffened, irrespective of supporting by tripping brackets arranged in accordance with the requirements specified in paragraph 3.6.4.

A primary supporting member web may be stiffened by means of stiffeners perpendicular to the flange and tripping brackets (see Fig. 3.6.3.1 a) or by stiffeners parallel to the flange and tripping brackets (see Fig. 3.6.3.1 b).

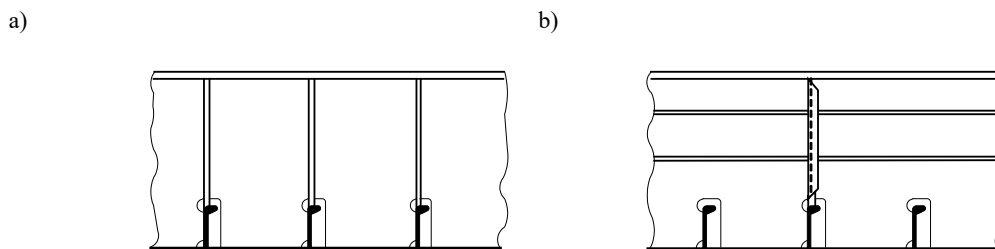

Fig. 3.6.3.1

3.6.3.2 Stiffeners of primary supporting member webs shown in Fig. 3.6.3.1 shall comply with the requirements specified in sub-chapter 13.5.3 regarding the buckling strength of stiffeners, for design stress values determined in accordance with 13.3.2.7 and 13.3.2.10.

3.6.3.3 Framing or strengthening of openings in webs as specified in 13.4.3.10 or 13.4.3.11 may be required for the purpose of meeting the primary supporting member web buckling strength criteria.

3.6.4 Tripping Brackets

3.6.4.1 Primary supporting member tripping brackets shall be fitted as required in paragraph 3.6.4.2, irrespective of stiffeners referred to in sub-chapter 3.6.3. Additionally, tripping brackets shall be fitted at the end parts of the primary supporting member (near toe of brackets, near rounded corner of primary supporting member frames) and in line with any cross ties.

3.6.4.2 In no case the spacing of tripping brackets shall exceed 3 m or $15 b_m$ (b_m – full breadth of primary supporting member flange), whichever is the lesser.

3.6.4.3 The thickness of tripping brackets shall not be less than the primary supporting member web thickness, according to the requirements of the present Part of the *Rules*.

3.6.4.4 Tripping brackets shall be extended to the flange and welded to it if the flange breadth measured from the web to the free edge exceeds 150 mm. Where the breadth of a flange symmetrical to the primary supporting member web exceeds 400 mm, a small bracket shall be fitted on a flange on the opposite side of tripping bracket.

3.6.4.5 The breadth of tripping bracket measured at its toe shall not be less than half of its depth.

3.6.4.6 Where the length of free edge l_k of tripping bracket exceeds $60ct_{wp}$ (t_{wp} – thickness of tripping bracket, [mm], $c = 1.0$ for steel; $c = 0.58$ for aluminium alloys), a flange or face plate shall be applied along the free edge. The cross-sectional area of flange or face plate shall not be less than:

$$f_k = 0.01l_k \text{ [cm}^2\text{]} \quad (3.6.4.6)$$

l_k – length of free edge, [mm].

3.7 Construction of water ballast tanks

3.7.1 Ballast water tanks and their internal structure shall be designed to avoid the accumulation of sediment in a ballast tank.

The following shall, as far as is practicable, be taken into account when designing ballast tanks:

- .1 horizontal surfaces shall be avoided wherever possible;
- .2 where longitudinals are fitted with face bar stiffeners, consideration shall be given to fit the face bar stiffeners below the horizontal surfaces to aid drain off from the stiffeners;
- .3 where horizontal stringers or webs are required, drainage holes shall be as large as possible, especially if edge toe-stops are fitted where horizontal stringers are used as walkways, to encourage rapid flow of water off them as the water level in the tank falls;
- .4 internal girders, longitudinals, stiffeners, intercostals and floors, where fitted, shall incorporate extra drain holes which allow water to flow with minimal restriction during discharge and stripping operations;
- .5 where inner members butt against bulkheads, their installation shall be such as to prevent the formation of stagnant pools or sediment traps;
- .6 scallops shall be located at the joints of the inner bottom (tank top) longitudinals or intercostals and floors to allow for good airflow, and thus drying out of an empty tank. This will also allow air to escape to the air pipe during filling so that minimum air is trapped within the tank;
- .7 pipeline systems shall be designed such that, when deballasting, disturbance of the water in the tank is as powerful as possible, so that the turbulence re-suspends sediment; and
- .8 flow patterns in ballast water tanks shall be studied (for example by the use of Computational Fluid Dynamics (CFD)) and considered, so that internal structure can be designed to provide effective flushing.

3.7.2 The design of all ships shall provide safe access to allow for sediment removal and sampling.

4 JOINTS OF STRUCTURAL ELEMENTS

4.1 General

4.1.1 The requirements concerning types and size of welds, welded and steel/aluminium alloys joints are specified in the present Chapter.

4.1.2 Irrespective of the requirements set forth in the present Chapter, the requirements concerning welding materials, welding methods, welders qualifications, quality control of welds and protection against atmospheric effects during welding, specified in *Part IX – Materials and Welding*, shall be complied with.

4.1.3 Welding sequence shall be so designed as to ensure possibly free material shrinkage.

4.2 Types and Size of Welds

4.2.1 Butt Joints

4.2.1.1 Edges of butt-welded plates of equal thickness shall be prepared as shown in Fig. 4.2.1.1.

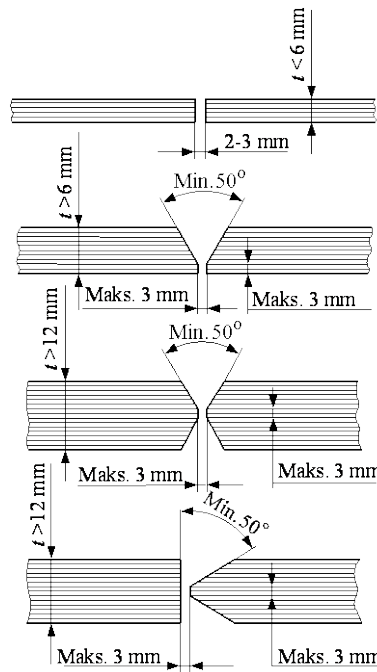

Fig. 4.2.1.1. Edge preparation for manual butt welding

4.2.1.2 Where two butt-welded plates are different in thickness by more than 3 mm, the thickness of the thicker plate shall be reduced by bevelling not exceeding 1:3. Upon reduction of the thickness, the edges shall be prepared for welding like the plates of equal thickness (see Fig. 4.2.1.2).

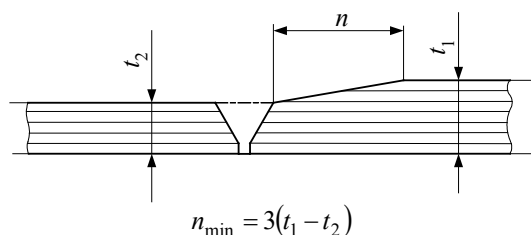

Fig. 4.2.1.2. Edge preparation for welding plates of different thickness

4.2.1.3 All types of butt welds shall be, in general, double side welded joints. Prior to welding the other side, the weld root shall be cut out to clean metal. Subject to PRS acceptance in each particular case, one side welding may be applied for low stressed structures or the structures where sealing weld is impossible.

4.2.2 Lap and Slot Welds

4.2.2.1 Examples of typical lap and slot welds are shown in Fig. 4.2.2.1.

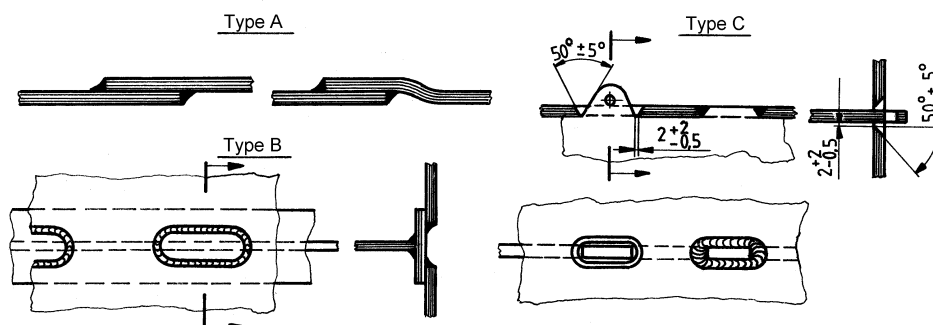

Fig. 4.2.2.1. Lap and slot welds

4.2.2.2 Type A (lap weld) may be used for welding brackets to ends of stiffeners for normally stressed joints except the areas where increased vibration may be expected.

4.2.2.3 B type (slot weld) and C type (pin slot weld) may be used for welding the plating to inner stiffeners – where fillet welding of T-joint is impossible. Dimensions and spacings of slots are subject to PRS consideration in each particular case.

4.2.2.4 Lap joints shall be made with continuous weld at the perimeter, with $\alpha = 0.4$ – see 4.2.3.1. The overlap width shall not be less than:

$$b = 2s + 25 \text{ [mm]}$$

and in no case shall be less than 50 mm (s – thickness of the thinner component, [mm]).

4.2.3 Fillet Welds

4.2.3.1 Design thickness a of fillet welds (see Fig. 4.2.3.1) shall not be less than the value determined in accordance with the following formula:

$$a = \alpha \beta s_0 + 0.5 t_k \text{ [mm]} \quad (4.2.3.1)$$

α – weld strength coefficient in accordance with Table 4.2.3.1-1; in tankers in the cargo tank area, the value of α shall be increased by 0.05 in relation to the values specified in the Table;
 β – coefficient determined in accordance with Table 4.2.3.1-2;

s_0 – net thickness of thinner component, [mm] $s_0 = s - t_k$; s – the component thickness;
 t_k – corrosion addition according to 2.5 [mm].

Fillet weld thickness a shall also be not less than:

- 2.5 mm + 0.5 t_k for $s_0 = 4$ mm ,
- 3.0 mm + 0.5 t_k for $4 < s_0 \leq 10$ mm,
- 3.5 mm + 0.5 t_k for $10 < s_0 \leq 15$ mm,
- 0.25 s_0 + 0.5 t_k for $s_0 > 15$ mm.

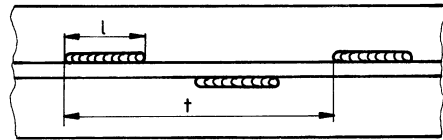

a) Staggered weld

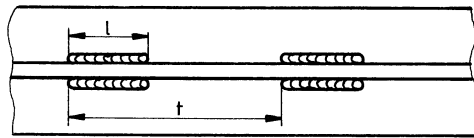

b) Chain weld

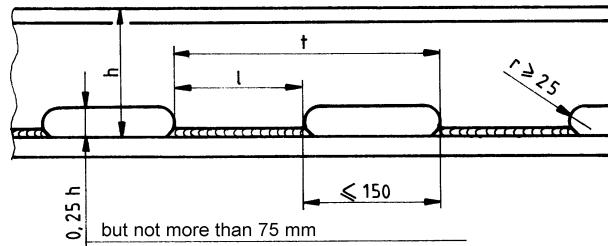

c) Scallop weld

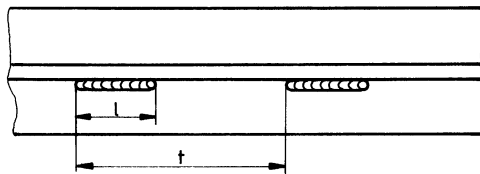

d) Single intermittent weld

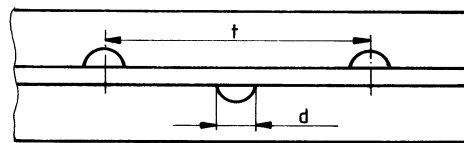

e) Staggered spot weld



f) Thickness a of fillet weld

Fig. 4.2.3.1. Types of fillet welds

Table 4.2.3.1-1

Item	Joint	$\alpha^1)$
1.	Bottom structure	
1.1	Central girder to outer and inner bottom plating, inner bottom to outer plating	0.40
1.2	Watertight floors and parts of bottom girders forming boundaries of tanks	0.35
1.3	Floors and side bottom stringers to each other, as well as to inner and outer bottom plating – within 0.25 L_0 from the fore perpendicular and in the machinery space area	0.25
1.4	Above specified joints in the remaining areas	0.20
2.	Side framing	
2.1	Frames (including web frames) and side stringers to shell plating within 0.25 L_0 from the fore perpendicular, in tanks, in machinery space, in way of ice strengthening as well as in the area of side reinforcements in ships intended for mooring at sea	0.17
2.2	Above specified joints in the remaining areas	0.13
2.3	Above specified joints in the after peak	0.25
2.4	Side stringers to web frames	0.25
3.	Deck and deck framing	
3.1	Transverse and longitudinal deck primary supporting members to the plating	0.17
3.2	Webs of deck transverses to deck stringers and bulkheads	0.25
3.3	Deck beams and stiffeners	0.15
3.4	Deck cantilevers to the plating	0.35
3.5	Stringer plate of strength deck to sheer strake	0.45 ²⁾
3.6	Stringer plate of other decks and platforms to the shell plating	0.35 ³⁾
3.7	Hatch coamings to deck at hatch corners	0.45 ²⁾
3.8	Face bars of hatch coamings to coamings	0.25
3.9	Outer walls and bulkheads of superstructures and deckhouses to upper deck	0.35 ³⁾
3.10	Pillars to decks and inner bottom, pillar brackets to pillars, decks, inner bottom and other structural members	0.35
4.	Bulkheads and partitions	
4.1	Bulkheads forming boundaries of the cargo or ballast tanks – at the circumference	0.35 ³⁾
4.2	Bulkhead stiffeners to the plating	0.15
4.3	Above specified joints in the peaks	0.25
4.4	Vertical and horizontal primary supporting members to the plating	0.17
4.5	Above specified joints in the peaks	0.30 ³⁾
4.6	Transverse bulkheads to longitudinal bulkheads	0.35 ³⁾
5.	Foundations of main machinery and boilers	
5.1	Web plates of foundations to shell plating, tank top and deck	0.35 ²⁾
5.2	Web plates of foundations to their face plates	0.45 ²⁾
5.3	Foundation brackets to foundation web plates, outer plating, inner bottom and deck	0.35 ²⁾
5.4	Brackets to their face plates	0.25
6.	Other joints	
6.1	Ends of primary supporting members within 0.15 of their span from the supporting points	0.25
6.2	Brackets interconnecting framing components	0.35

¹⁾All welded joints of watertight structures shall be made with double continuous weld.

²⁾Full penetration welds shall be used.

³⁾Double continuous weld is required.

Table 4.2.3.1-2

Item	Type of fillet weld	β
1	Double continuous weld	1.0
2	Staggered, chain and scallop weld	t/l
3	Single continuous weld	2.0
4	Single intermittent weld	$2t/l$

t – weld pitch,

l – weld length (see Fig. 4.2.3.1).

4.2.3.2 In highly stressed joints, the plate edges shall be bevelled to ensure full penetration or deep fusion weld. The following joints shall be welded with full penetration:

- strength deck stringer to sheer strake,
- in way of machinery foundations (see Table 4.2.3.1-1),
- hatch coamings with deck at hatch corners,
- rudder horns and shaft propeller brackets to shell plating,
- rudder blade plating to the flange connecting the rudder blade with rudder stock.

4.2.3.3 For such joints as:

- transverse bulkhead to double bottom or stool,
- structural elements in double bottom under bulkhead or stool,
- transverse primary supporting members of central tanks to longitudinal bulkhead,
- bulkhead stool to inner bottom and hopper tank,
- joints of discontinuous primary supporting members (in order to ensure their continuity) with webs of the structure where the primary supporting members are interrupted,

fillet weld thickness shall be increased or full penetration weld shall be applied.

4.2.3.4 The weld thickness and cross-section of highly stressed welded joints are subject to PRS consideration in each particular case.

4.2.3.5 Structural elements and parts of members cut at the plating or at the crossing structures shall be coplanar. The maximum shift of the planes of interrupted structural elements and members shall not be greater than half of their thickness and not greater than that determined in Fig. 4.2.3.5.

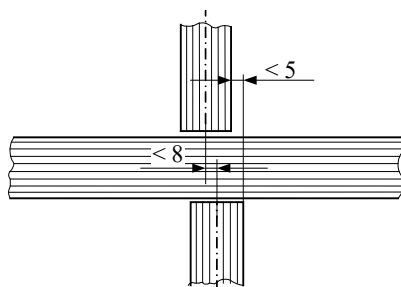

Fig. 4.2.3.5. Shift of interrupted planes

4.2.3.6 Double continuous welds are required:

- for watertight, oiltight and weathertight joints,
- within $0.25 L_0$ from the fore perpendicular – for welding structural members to the bottom plating,
- within ice belt of ships with ice strengthening **L1A**, **L1** and **L2**,
- for welding side framing to the outer plating,

- in the area of pillars and at the ends of structural elements,
- in machinery foundation and supporting structures,
- for all joints in the after peak,
- for joints inside the rudder blade, except the cases where slot welding is necessary,
- for connecting bottom central girder to the keel plate.

4.2.3.7 Intermittent welds may be used for less stressed joints – inside dry spaces and oil fuel tanks.

4.2.3.8 Inside ballast, cargo or fresh water tanks, inside the spaces where water may be accumulated or condensed, as well as inside empty, closed spaces exposed to corrosion (such as rudder blades), continuous welds shall be applied for heavily or dynamically stressed joints, or scalloped welds – for less stressed joints.

4.2.3.9 The length of intermittent weld l (see Fig. 4.2.3.1) shall not be less than $15a$ and shall be to at least 50 mm. The distance between the weld sections (for chain and scallop welds amounting to $t - l$ and for staggered welds $\frac{t - 2l}{2}$) shall not be greater than $25s$ or 150 mm – whichever is the lesser (s – the thickness of the thinner element, in mm). The depth of scallops shall not be greater than 0.25 of the section depth and shall not exceed 75 mm. The rounding radius of scallop shall not be less than 25 mm.

4.2.3.10 Double continuous welds shall be used in the area of pillars, at ends of structural members and at the places where supporting members (deck primary supporting members, floors, etc.) pass through structural members. The length of double continuous weld sections shall not be less than:

- bracket length – where applied,
- double depth of element – where brackets are not applied.

4.2.3.11 The distance from scallops of frames, deck beams, stiffeners, etc. to the ends of these elements and supports (primary supporting members) shall not be less than double depth of the section, and the distance to the bracket ends shall be at least equal to half of the section depth.

4.2.3.12 Staggered spot welds, as well as single intermittent welds may be applied for joints in the second and higher tier of superstructures and deckhouses, as well as for elements in enclosed deck areas in the first tier of superstructures. Where the thickness of section or plate is less than 7 mm, the spot weld may be used for joints in structures of casings and walls in these areas of hull, where neither variable nor impact loads nor strong corrosive agents occur.

4.3 End Connections of Structural Members

4.3.1 End connections of structural members shall be, in general, butt joints.

Subject to PRS acceptance in each particular case, lap joints may be applied, except:

- areas of increased vibrations,
- joints of web frames and primary supporting members,
- areas subjected to great concentrated loads.

Brackets shall be, in general, made of material of the same yield stress as the adjacent elements of framing.

4.3.2 For bracket scantlings – see 13.8.

4.3.3 Free ends of bracket face plates or flanges shall be snipped to the width not greater than 3 times the thickness of the bracket web or 40 mm (whichever is the lesser). The length of the snipped part shall not be less than the width of face plate.

4.3.4 In places of transition from the face plates of brackets to those of structural members, the butts of the face plates shall be kept at least 150 mm away from the toes of the brackets, and the angle formed by the bracket face plate and the direction of the members face plate shall not exceed 45°.

4.3.5 Joints of the lower ends of frames with bilge brackets or floors shall be made as shown in Fig. 4.3.5.

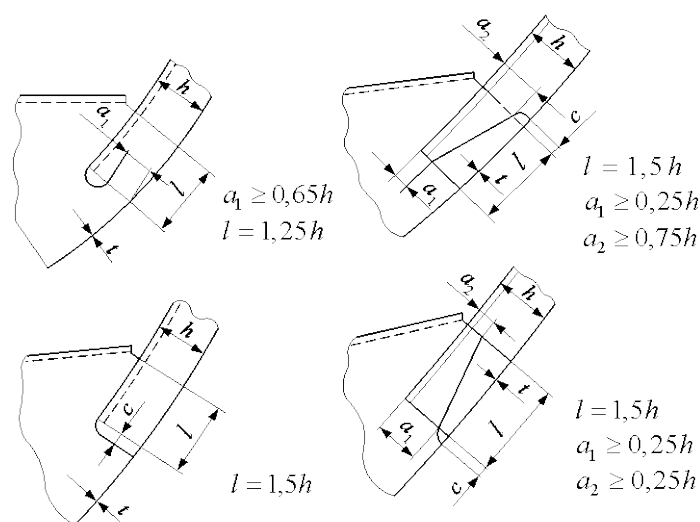

$c \leq 50 \text{ mm}$ or $c \leq 5s$, whichever is the lesser.

Fig. 4.3.5. Connections of bottom ends of frames

4.3.6 Depending upon the design of the detail, the ends of face plates and/or webs of the structural members shall be snipped at ends over a length equal to 1.5 times the face plate width or 1.5 times the web depth. The blunting at the snipped free end shall be as follows:

- for face plate – equal to 3 times its thickness,
- for web – 10÷15 mm.

The distance between snipped end of structural element and the nearest member perpendicular to this element shall be, in general, not greater than 25 mm.

4.3.7 Stiffeners may be connected to the web plate of primary supporting members in one of the ways shown in Fig 4.3.7.

In locations with great shear stresses in the web plate, a double-sided connection or a stiffening of the unconnected web plate edge is required. A double-sided connection may be taken into account when calculating the effective web area.

Connection lugs shall have a thickness not less than 75% of the web plate thickness.

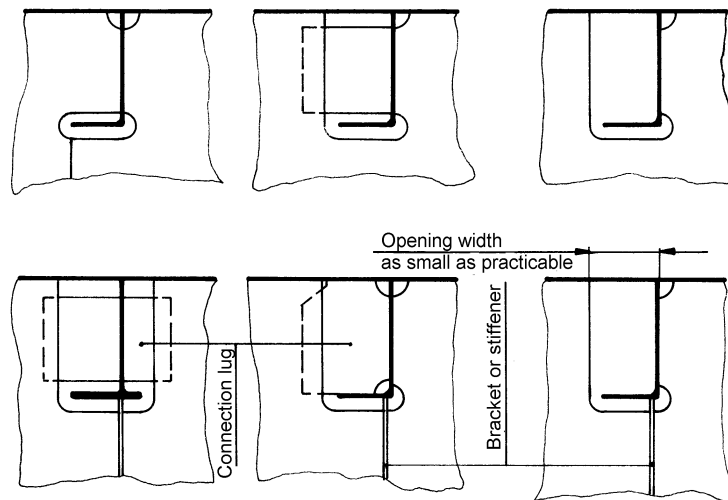

Fig. 4.3.7. Connection of a stiffener to the web plate of a primary supporting member

4.4 Connection of Different Material Structures

Bolted connections or special connecting elements (e.g. made with the use of explosive method) may be applied for connections of different materials (e.g. steel/aluminium alloys).

These connections will be specially considered by PRS. The strength of connection shall not be less than that of the bolted connection and the corrosion protection shall be equally satisfactory.

5 PRINCIPLES OF HULL STRUCTURAL REQUIREMENTS

5.1 General

5.1.1 Graduation of Requirements

The requirements specified in the present Chapter apply to the hull structure strength analysis within the following extent:

- local strength within one structural member (e.g. part of the plate within its supporting stiffeners, stiffener, simple primary supporting member), see Chapter 13;
- zone strength within one structure (relating to the primary supporting member system of a fragment of bottom, sides, deck, bulkhead, etc. or a hull module comprising fragments of several structures mentioned above), see Chapter 14;
- general strength within the whole hull, see Chapter 15.

The requirements concerning fatigue strength analysis of a hull structure are specified in Chapters 18, 20 and 21, as well as in *Publication 45/P – Fatigue Strength Analysis of Ship Steel Hull Structure*.

5.1.2 Local Strength

The requirements regarding the local strength apply to the scantlings of plating, stiffeners, pillars, cross ties, brackets and ordinary primary supporting members. Boundary conditions for these members are known with sufficient accuracy. In such case the influence of the remaining part of the structure on the considered member may be directly taken into account in formulae determining the scantlings of the given members.

5.1.3 Zone Strength

5.1.3.1 When the boundary conditions of primary supporting members, stiffeners or cross ties cannot be determined with sufficient accuracy and, as a result, the scantlings of primary supporting members cannot be established on the basis of local strength requirements, the scantlings of primary supporting members shall be based on the zone strength analysis of the hull.

5.1.3.2 Zone may cover both a part of the single structure (e.g. bottom, sides) and a part of several structures in way of one or several cargo holds, tanks or other spaces. Zone boundaries are affixed in places of known boundary conditions.

5.1.3.3 Modelling the selected zone of the hull structure consists in reducing it to the system of principal primary supporting members which support the local structural members.

5.1.3.4 Zone strength calculations relate to cases specified in the present Part of the *Rules* and shall be performed in accordance with the relevant *Publications*.

5.1.4 Hull Girder Strength

The requirements for the ship's hull girder strength refer to the longitudinal bending and shear strength. In ships with combined hatch breadth in one cross-section (measured in the middle of the hatch length) greater than $0.6b$ (b – breadth of the strength deck in the cross-section), the additional stresses from the hull torsion and horizontal bending shall be checked.

5.2 Basis for Requirements

5.2.1 Basic Problems

The following basic problems of the structure design:

- establishing the design loads,
- evaluation of the structure response to the loads,
- establishing the allowable ranges of the structural response parameters in respect of the assumed strength criteria,

have been solved for the relevant hull structure strength levels. These solutions constitute the basis for detailed requirements specified in the present Part of the *Rules*.

5.2.2 Structure Loads

5.2.2.1 Static and dynamic loads imposed by the sea and by the cargo, stores, larger concentrated mass of cargo and equipment have been taken into account in determining design loads of hull structure given in the present Part of the *Rules*. In special cases, the impact loads imposed by waves and by liquid in partially filled tanks have been taken into account.

5.2.2.2 Design static loads are determined for typical loading conditions of the ship specified by the Owner (designer). The typical loading conditions for various ship types are specified in the present Part of the *Rules*; these loading conditions shall be taken into account in calculations.

5.2.2.3 The requirements concerning the design dynamic loads have been specified on the basis of long-term forecast of ship motions within her operating life. The operating life is normally taken to correspond to 10^8 wave encounters in the North Atlantic. Wave-induced loads determined according to recognized theories, model tests or full-scale measurements may be accepted as equivalent for classification purposes.

5.2.3 Structure Response

5.2.3.1 The requirements concerning structure response, such as stresses or strains in various points and sections of local members (plate panels, stiffeners or simple primary supporting members), have been based on the theories of elasticity and plasticity, taking into account the assumed boundary conditions.

5.2.3.2 The thickness of plating exposed to lateral pressure shall be determined by the formula:

$$t = 18 k_a s \sqrt{\frac{p}{\sigma}} + t_k \text{ [mm]} \quad (5.2.3.2-1)$$

k_a – correction factor depending on the aspect ratio of plate field:

$$k_a = \left(1 - 0.27 \frac{s}{l}\right)^2 \quad (5.2.3.2-2)$$

k_a need not be greater than 0.88;

s – length of shorter side of plate field, [m];

l – length of longer side of plate field, [m];

p – design lateral pressure imposed on plate field, [kPa];

t_k – corrosion addition (see 2.5), [mm];

σ – allowable stresses, [MPa].

5.2.3.3 For stiffeners exposed to lateral pressure acting on the supported plating, the required section modulus W is given as a function of boundary conditions at the stiffeners' ends and the allowable bending stress:

$$W = \frac{1000ql^2}{m\sigma} \text{ [cm}^3\text{]} \quad (5.2.3.3)$$

q = pb ;

p – see 5.2.3.2;

b – width of plating strake supported by the stiffener in question, [m];

l – stiffener span, [m];

σ – allowable bending stress, [MPa];

m – bending moment coefficient taking into account boundary and load conditions of the stiffener. The values of coefficient m are given separately for particular groups of structural members in Chapter 13. For the scantlings of structural members within the scope of elastic deflection, the values of coefficient m have been determined directly from general elastic bending theory.

The values of coefficient m for specified load and boundary conditions are given in Table 5.2.3.3.

5.2.3.4 The cross-sectional area requirement for stiffeners, subjected to shear stress, is given as a function of boundary conditions and allowable shear stress.

The value of cross-sectional area of a stiffener is determined by the formula:

$$A = 10 \frac{k_t P}{\tau} \text{ [cm}^2\text{]} \quad (5.2.3.4)$$



τ – allowable shear stress, [MPa];

P – combined transverse load on the stiffener, [kN];

k_t – transverse force coefficient taking into account boundary and load conditions.

The values of coefficient k_t for certain load and boundary conditions are given in Table 5.2.3.3.

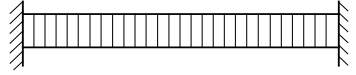
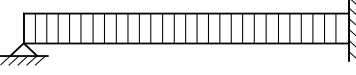
Table 5.2.3.3
Values of coefficients m and k_t

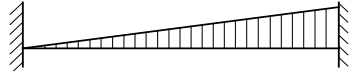
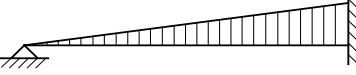
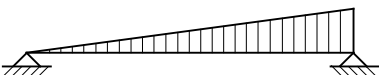
Load and boundary conditions			Bending moment and shear force coefficients		
Position			1	2	3
1 Support	2 Field	3 Support	m_1	m_2	m_3
between supports			k_{t1}	-	k_{t3}
			12.0	24.0	12.0
			0.50	-	0.50
			-	14.2	8.0
			0.38	-	0.63
			-	8.0	-
			0.50	-	0.50
			15	23.3	10
			0.30	-	0.70
			-	16.8	7.5
			0.20	-	0.80
			-	7.8	-
			0.33	-	0.67

5.2.3.5 The scantlings of the elements of primary supporting members subjected to bending moments are determined in accordance with the provisions specified in 5.2.3.3 for stiffeners. The given formulae are applicable to simple primary supporting members, i.e. primary supporting members which may be modeled by a single-span beam with the known boundary conditions.

5.2.3.6 Where primary supporting members do not meet the conditions specified in 5.2.3.5, the structural response shall be determined on the basis of adequate methods of the zone strength analysis.

It is recommended that computerized matrix methods of structural analysis based on the bar idealization of structure or on other types of finite element idealization of structure should be used.

5.2.3.7 The requirements concerning the response of hull structure to the hull girder bending loads is based on the linear bending theory of simple beam.

5.2.3.8 Special means shall be provided in way of the afterbody and machinery space to preclude excessive vibration of the structure. Guidelines referring to the above problem are given in *Publication 2/I – Prevention of Vibration in Ships*.

6 BOTTOM STRUCTURES

6.1 General

6.1.1 Application

The requirements specified in the present Chapter apply to the single and double bottom structures defined in 1.2.5.

6.1.2 Double Bottom in Passenger Ships and Cargo Ships (other than Tankers)

6.1.2.1 A double bottom* shall be fitted extending from the collision bulkhead to the afterpeak bulkhead, as far as this is practicable and compatible with the design and proper working of the ship. (SOLAS II-1/9.1)

* Explanatory notes – see MSC.429(98)/Rev.2.

6.1.2.2 Where a double bottom is required to be fitted the inner bottom shall be continued out to the ship's sides in such a manner as to protect the bottom to the turn of the bilge. Such protection will be deemed satisfactory if the inner bottom is not lower at any part than a plane parallel with the keel line and which is located not less than a vertical distance h measured from the keel line, as calculated by the formula:

$$h = B/20 \quad (6.1.2.2)$$

However, in no case is the value of h to be less than 760 mm, and need not be taken as more than 2.0 m. (SOLAS II-1/9.2)

* Explanatory notes – see MSC.429(98)/Rev.2.

6.1.2.3 A double bottom need not be fitted in way of watertight tanks, including dry tanks of moderate size, provided the safety of the ship is not impaired in the event of bottom or side damage. (SOLAS II-1/9.4)

6.1.2.4 In the case of passenger ships to which the provisions of SOLAS regulation 1.5 apply and which are engaged on regular service within the limits of a short international voyage as defined in SOLAS regulation III/3.22, PRS may permit a double bottom to be dispensed with if satisfied that the fitting of a double bottom in that part would not be compatible with the design and proper working of the ship. (SOLAS II-1/9.5)

6.1.2.5 Any part of a cargo ship of 80 m in length and upwards or of a passenger ship that is not fitted with a double bottom in accordance with par. 6.1.2.1, 6.1.2.3 or 6.1.2.4 (SOLAS par. II-1/9.1, /9.4 or /9.5), as specified in paragraph 6.1.2.2, shall be capable of withstanding bottom damages, as specified in par. 6.1.2.7 (SOLAS par. /9.8), in that part of the ship. For cargo ships of less than 80 m in length the alternative arrangements shall provide a level of safety to the satisfaction of the Administration. (SOLAS II-1/9.6)

* Explanatory notes – see MSC.429(98)/Rev.2.

6.1.2.6 In the case of unusual bottom arrangements in a cargo ship of 80 m in length and upwards or a passenger ship, it shall be demonstrated that the ship is capable of withstanding bottom damages as specified in par. 6.1.2.7 (SOLAS par. /9.8). For cargo ships of less than 80 m in length the alternative arrangements shall provide a level of safety to the satisfaction of PRS. (SOLAS II-1/9.7)

* Explanatory notes – see MSC.429(98)/Rev.2.

6.1.2.7 Compliance with par. 6.2.11.1, 6.2.11.3, 6.1.2.5 and 6.1.2.6 (SOLAS par. II-1/9.3.1, /9.3.2.1, /9.6 or /9.7) is to be achieved by demonstrating that s_i , when calculated in accordance with SOLAS regulation II-1/7-2 (as amended by MSC.474(102)), is not less than 1 for all service conditions when subject to bottom damage with an extent specified in subparagraph .2 below for any position in the affected part of the ship:

- .1 Flooding of such spaces shall not render emergency power and lighting, internal communication, signals or other emergency devices inoperable in other parts of the ship.
- .2 Assumed extent of damage shall be as follows:

	For $0.3 L$ from the forward perpendicular of the ship	Any other part of the ship
Longitudinal extent	$1/3 L$ or 14.5 m, whichever is less	$1/3 L$ or 14.5 m, whichever is less
Transverse extent	$B/6$ or 10 m, whichever is less	$B/6$ or 5 m, whichever is less
Vertical extent, measured from the keel line	$B/20$, to be taken not less than 0.76 m and not more than 2 m	$B/20$, to be taken not less than 0.76 m and not more than 2 m

- .3 If any damage of a lesser extent than the maximum damage specified in .2 would result in a more severe condition, such damage should be considered. (SOLAS II-1/9.8)

* Explanatory notes – see MSC.429(98)/Rev.2.

6.1.2.8 In case of large lower holds in passenger ships, the PRS may require an increased double bottom height of not more than $B/10$ or 3 m, whichever is less, measured from the keel line. Alternatively, bottom damages may be calculated for these areas, in accordance with par. 6.1.2.7 (SOLAS II-1/9.8), but assuming an increased vertical extent. (SOLAS II-1/9.9)

* Explanatory notes – see MSC.429(98)/Rev.2.

6.1.3 Oil Fuel Tanks in Double Bottom or Nearby

If aggregate capacity of the ship's oil fuel tanks amounts to 600 m³ and above, the oil fuel tanks in double bottom or nearby shall be arranged so that the requirements of regulation 12A of Annex I to *MARPOL Convention 73/78* are complied with.

For ships designed with a permanent trim, the centre plane shall not be used as a reference point. The distance h shall be measured perpendicular to the moulded line of the bottom shell plating at the relevant frames where fuel tanks are to be protected.

For ships designed with a skeg, the skeg shall not be considered as offering protection for the fuel oil tanks. For the area within skeg's width, the distance h shall be measured perpendicular to a line parallel to the centre plane at the intersection of the skeg and the moulded line of the bottom shell plating as indicated in Figure 6.1.3-1.

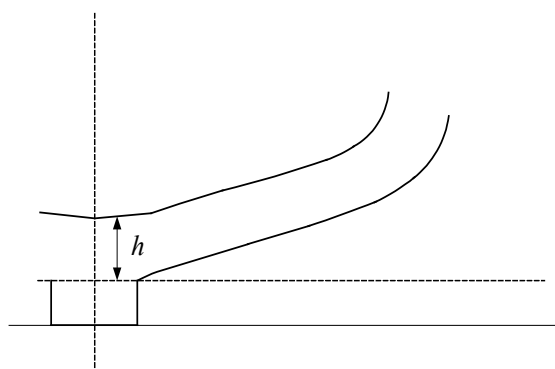

Fig. 6.1.3-1

For ships designed with dead rising bottom, the distance $1.5h$ shall be measured from the moulded line of the bottom shell plating but at right angle to the centre plane, as indicated in Figure 6.1.3-2.

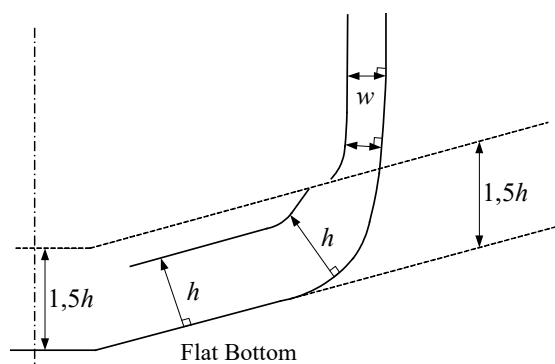

Fig. 6.1.3-2

6.2 Double Bottom Structure

6.2.1 General Requirements

6.2.1.1 If the seating frame of the main engine, thrust bearing and boiler is fastened directly to the inner bottom, then the floors, longitudinals and inner bottom plating shall comply with the relevant requirements specified in Chapter 12.

In way of the main engine, thrust bearing and boilers, additional strengthening of the bottom shall be provided.

Strengthenings shall also be applied under pillars and bulkheads or walls supporting the upper parts of hull structure.

6.2.1.2 Double bottom, forepeak and after-peak ballast tanks shall be so designed as to comply with the recommendations specified in IMO MSC/Circ.1021; provision shall be made, in particular, for good flow of ballast water into the ballast water suction pipes and for preventing accumulation of water residues and sediments in the tanks.

6.2.2 Framing System

6.2.2.1 It is recommended that in ships with length $L_0 \geq 150$ m, double bottom within the cargo area should be longitudinally stiffened.

6.2.2.2 If the outer bottom or the inner bottom is longitudinally stiffened, then:

- in ships with $L_0 \geq 150$ m, the longitudinals shall be continuous through floors within $-0.25L_0 \leq x < +0.25L_0$ amidships;
- in ships with $50 \text{ m} < L_0 < 150$ m, the longitudinals may be cut at floors within $-0.25L_0 \leq x < +0.25L_0$ amidships; in that case, continuous brackets connecting the ends of the longitudinals shall be fitted, or the continuity shall be provided otherwise;
- in ships with $L_0 \leq 50$ m, the longitudinals over the entire ship length may be cut at bottom floors and welded to them;
- outside $-0.25L_0 \leq x < +0.25L_0$ amidships, longitudinals may be cut and welded to the floors, irrespective of the ship's length.

6.2.3 Arrangement of Double Bottom Primary Supporting Members

The arrangement of bottom primary supporting members and plate floors shall comply with the requirements specified in 6.2.4 to 6.2.6 and in 6.6.1.

The arrangement of primary supporting members in the double bottom may be different, provided that the requirements for local strength (see Chapter 13) and possibly for zone strength (see Chapter 14) are complied with.

6.2.4 Bottom Centre Girder and Duct Keel

6.2.4.1 Bottom centre girder shall be fitted in the ship's centre plane. It shall extend fore and aft as far as possible. The centre girder shall be continuous within $-0.3L_0 \leq x \leq 0.3L_0$.

6.2.4.2 In ships with the double bottom, a duct keel made of two longitudinal girders fitted on both sides of the centre plane may be applied instead of the bottom centre girder. Generally, the distance between girders shall not exceed the value determined by the formula:

$$b = 0.004L_0 + 1.0 \quad [\text{m}] \quad (6.2.4.2)$$

however, it shall be not more than 1.9 m.

Subject to PRS consideration in each particular case, this distance may be increased.

Supporting plates or transverse stiffeners with brackets shall be fitted on the outer and inner bottom plating between these girders in line with each frame (and spaced not more than 0.9 m).

6.2.4.3 Where the duct keel is extended over a part of the ship's length only, and the ordinary centre girder is applied in the remaining part, they have to overlap at the length equal to at least half the depth of the double bottom (this length cannot be greater than the frame spacing). Flanged brackets shall be fitted in line at the ends of girders. If the alteration of the centre girder structure takes place within $-0.3L_0 \leq x \leq 0.3L_0$, the length of brackets shall be equal to at least the double bottom depth and in other cases – to at least two-thirds of the double bottom depth.

6.2.5 Arrangement of Side Girders

6.2.5.1 Side girders in the double bottom shall be so fitted that the distance between the side girder and the centre girder or the margin plate or between adjacent side girders does not exceed the following values:

- 5 m – for longitudinal framing,
- 4 m – for transverse framing.

6.2.5.2 Girders in the machinery space shall be fitted in compliance with the location of the engine and other heavy machinery seatings.

6.2.6 Arrangement of Plate Floors

6.2.6.1 In the double bottom with transverse framing, the plate floor spacing shall not be greater than that specified in Table 6.2.6.4.

6.2.6.2 In the double bottom with longitudinal framing, the plate floor spacing shall not be greater than 3.6 m, and in way of deep tanks it shall not exceed 2.5 m.

6.2.6.3 In the double bottom within the machinery space with transverse framing, plate floors shall be fitted at every frame.

6.2.6.4 In the double bottom within the machinery space with longitudinal framing, plate floors shall be spaced not more than the depth of the double bottom. In way of the engine seating between external girders adjacent to the seating girders, plate floors shall be fitted at every frame.

Table 6.2.6.4
Arrangement of plate floors in double bottom

Draught T [m]	Under deep tanks ¹⁾	Clear of deep tanks and machinery space ²⁾
$T \leq 2$	Every 4th frame	Every 6th frame
$2 < T \leq 5.4$	Every 3rd frame	Every 5th frame
$5.4 < T \leq 8.1$	Every 3rd frame	Every 4th frame
$T > 8.1$	Every 2nd frame	Every 3rd frame

¹⁾ Where the height of deep tank is greater than 0.7 times the distance between the inner bottom and the bulkhead deck.

²⁾ The distance between floors shall not exceed 3 m.

6.2.7 Arrangement of Supporting Plates in Double Bottom

6.2.7.1 Supporting plates shall be fitted at both sides of the bottom centre girder and at least at one side of stringers, duct girders and margin plate. In the case of longitudinal framing, supporting plates shall extend to the nearest longitudinal. See also 6.3.3.4.

A face plate or flange shall be provided for the free edge of the supporting plate.

6.2.7.2 In longitudinally stiffened double bottom, the supporting plate spacing shall not exceed the depth of the double bottom; on the duct girders, the supporting plate spacing shall not exceed half the depth of the double bottom.

Where the ship side is transversely framed, supporting plates in double bottom on the margin plate shall be fitted at every frame.

Docking brackets, extended to the nearest longitudinal, shall be fitted between supporting plates on the centre girder.

6.2.7.3 In transversely stiffened double bottom, supporting plates shall be fitted on frames without plate floors at bottom centre girder and at margin plate.

6.2.8 Manholes, Holes and Cut-outs

6.2.8.1 To provide access to all parts of the double bottom, manholes shall be cut in the inner bottom plating and holes shall be cut in plate floors and longitudinal girders. The openings, their arrangement and size shall comply with the requirements of sub-chapter 3.5 and the requirements of sub-chapter 6.2.8, given below.

In addition, recommendations specified in IMO MSC/Circ.1021 shall be taken into account.

6.2.8.2 Manholes in the inner bottom plating shall comply with the requirements specified in *Part III – Hull Equipment*.

6.2.8.3 Manholes in the inner bottom plating provided for access to the fuel tanks in way of the machinery space shall have coamings, the height of which shall be equal to at least 100 mm.

6.2.8.4 Diameter of the lightening holes in brackets of the bracket floors shall not be greater than 1/3 of the breadth of the brackets.

6.2.8.5 Distance between edges of two adjacent holes shall not be less than half the breadth of the greater hole.

6.2.8.6 Only indispensable number of cut-outs and manholes shall be provided in side girders and plate floors within $x > 0.25L_0$.

6.2.8.7 Drain holes and air holes shall be cut in accordance with the requirements specified in 3.5.1.1 and 3.5.1.5.

6.2.8.8 Openings shall not be cut in:

- the keel plate;
- the bilge strake within $-0.3L_0 \leq x \leq +0.3L_0$; the necessary holes shall be located as far from the bilge keel as possible.

6.2.8.9 Holes shall normally not be cut in:

- bottom centre girder – within $x > 0.25L_0$,
- side girders and floors – under the supports and at the ends of longitudinal partitions or wash bulkheads,
- bottom centre girder and in side girders – between a transverse bulkhead and adjacent plate floors,
- floors – in areas adjacent to the margin plate and centre girder, as well as in way of toes of transverse brackets supporting seatings of the main machinery.

In special cases, openings may be cut in the above-mentioned members, provided they are reinforced by stiffeners or by a flat bar welded to the edge.

Location and dimensions of holes may be also assumed on the basis of stress analysis in accordance with the requirements specified in Chapter 13 and Chapter 14 and fatigue strength analysis – on the basis of *Publication 45/P – Fatigue Strength Analysis of Ship Steel Hull Structure*.

6.2.9 Discontinuity of the Double Bottom

In areas where double bottom terminates, smooth transitions from double bottom girders to single bottom girders shall be provided.

Gradual transition of inner bottom plating into face plates of bottom centre girder and bottom side girders, at the length equal to at least the depth of the double bottom, shall be provided. The width of these face plates at the double bottom ends shall not be less than half the distance between adjacent side girders.

Margin plates shall be extended outside the double bottom and shall form a bracket, the length of which shall not be less than three frame spacings, with flat bar or flange at the free edge.

6.2.10 Abrupt Change of Double Bottom Depth

6.2.10.1 The change of double bottom depth may have the form of two bends or a step. Bends of the inner bottom shall be arranged on a transverse bulkhead and plate floor.

Both bends may be arranged on plate floors subject to PRS acceptance in each particular case.

6.2.10.2 When the depth of the double bottom is changed abruptly, the change (step) shall be normally arranged on a transverse bulkhead.

6.2.10.3 In way of a step, the inner bottom plating of smaller height shall be extended by a distance equal to at least the height of the double bottom in ships with $L_0 \geq 90$ m and by a distance of $2/3$ of the double bottom height for ships with $L_0 < 90$ m.

When the step is outside $-0.25 L_0 \leq x \leq +0.25 L_0$ or when its height is less than 660 mm, the double bottom structure in way of extension is subject to PRS consideration in each particular case.

6.2.10.4 Continuity of structure and reduction of stress concentration shall be provided in places where the height of bottom centre girder, bottom side girders, margin plates and inner bottom longitudinals, if applied, is altered.

6.2.11 Drain Wells

6.2.11.1 Small wells constructed in the double bottom in connection with drainage arrangements shall not extend downward more than necessary. The vertical distance from the bottom of such a well to a plane coinciding with the keel line shall not be less than $h/2$ or 500 mm, whichever is greater, or compliance with par. 6.1.2.7 (SOLAS II-1/9.8) of this regulation shall be shown for that part of the ship. (SOLAS II-1/9.3.1)

6.2.11.2 Other wells (e.g. for lubricating oil under main engines) may be permitted by the Administration if satisfied that the arrangements give protection equivalent to that afforded by a double bottom complying with this regulation. (SOLAS II-1/9.3.2)

6.2.11.3 For a cargo ship of 80 m in length and upwards or for a passenger ship, proof of equivalent protection is to be shown by demonstrating that the ship is capable of withstanding bottom damages as specified in paragraph 6.1.2.7 (SOLAS II-1/9.8). Alternatively, wells for lubricating oil below main engines may protrude into the double bottom below the boundary line defined by the distance h provided that the vertical distance between the well bottom and a plane coinciding with the keel line is not less than $h/2$ or 500 mm, whichever is greater. (SOLAS II-1/9.3.2.1)

6.2.11.4 For cargo ships of less than 80 m in length the arrangements shall provide a level of safety to the satisfaction of the Administration. (SOLAS II-1/9.3.2.2)

* Explanatory notes – see MSC.429(98)/Rev.2.

6.3 Scantlings of the Double Bottom

6.3.1 Double Bottom Depth

6.3.1.1 The height of centre girder and the attached plate floors shall not be less than:

$$h_d = 250 + 20 B + 50 T \quad [\text{mm}] \quad (6.3.1.1)$$

For ships with a great rise of floors, the value of h_d may be required to be increased.

6.3.1.2 The depth of the double bottom shall be sufficient to give good access to all parts of the bottom. The depth shall not be less than 650 mm.

6.3.1.3 In the machinery space, in way of seating of internal combustion main engine and the gear, the depth of the double bottom shall be increased by 45% where the sump tank is under the main engine, and by 30% in other cases.

6.3.2 Inner and Outer Bottom Plating

6.3.2.1 The thickness of the plating of outer and inner bottom shall be determined in accordance with the requirements specified in 13.2.2 and 13.4.2.

6.3.2.2 The thickness of the bottom plating in the forebody shall be additionally checked for slamming pressure in accordance with the requirements specified in 6.7.2.

6.3.2.3 The thickness of keel plate shall not be less than that of the adjacent bottom plating.

6.3.2.4 The width of keel plate shall not be less than that determined by the formula:

$$b = 800 + 5L_0 \quad [\text{mm}] \quad (6.3.2.4)$$

however, need not be greater than 1800 mm.

6.3.2.5 If the bilge plating is not stiffened or is stiffened by one stiffener only fitted in the curved part of the bilge, the thickness of the bilge plating shall not be less than:

$$t = 1.11 \sqrt[3]{R_0^2 l p} + t_k \quad [\text{mm}] \quad (6.3.2.5-1)$$

where:

R_0 – radius of the curvature (Fig. 6.3.2.5), [m];

l – distance between supporting plates (or floors) stiffening the bilge, [m];

p – design pressure according to 16.2.2.1, [kPa];

t_k – corrosion addition according to sub-chapter 2.5.

If longitudinal stiffeners in way of the bilge are fitted outside the curved part (Fig. 6.3.2.5), then R_0 shall be substituted by R in formula 6.3.2.5-1:

$$R = R_0 + 0.5(s_3 + s_4) \quad (6.3.2.5-2)$$

where:

s_3, s_4 – see Fig. 6.3.2.5.

The value of s_3 shall be not greater than s_1 and the value of s_4 – not greater than s_2 .

Furthermore, the thickness of the bilge plating shall be not less than that of the adjacent bottom and side plating.

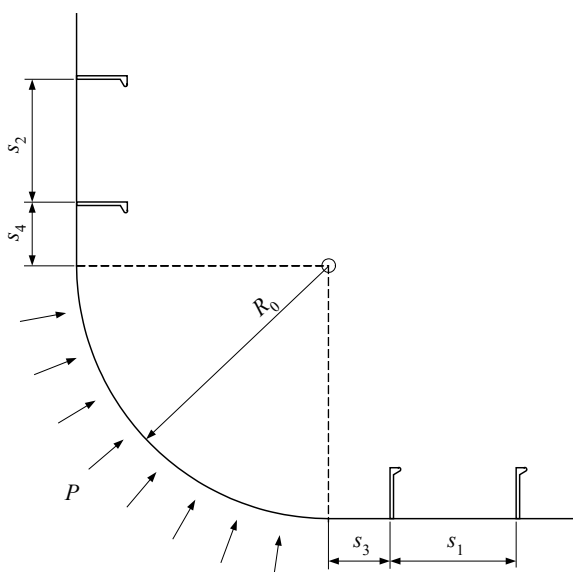

Fig. 6.3.2.5

6.3.2.6 When, according to the requirements specified in 2.2, steel grade higher than A is required for bilge strake or outer bottom strake, to which an effective longitudinal bulkhead is attached, the breadth of the strake shall not be less than that required in paragraph 6.3.2.4.

6.3.2.7 The breadth of the sloped margin plate over the entire ship's length shall not be less than:

$$b = 0.0035L_0 + 0.40 \text{ [m]} \quad (6.3.2.7)$$

6.3.2.8 The breadth of the horizontal margin plate shall not be less than the breadth of the tank side bracket increased by the height of the ship side frame section and additionally by 50 mm.

Where bottom members are attached to the ship side frames without tank side brackets, the breadth of the horizontal margin plate shall not be less than that determined in accordance with formula 6.3.2.7.

6.3.2.9 The thickness of the margin plate shall be greater than that of the inner bottom, required in 6.3.2.1, in the same region of the ship's hold, as follows:

- the thickness of the horizontal margin plate shall be increased by 1 mm,
- the thickness of the sloped margin plate shall be increased by 2 mm.

The thickness of the margin plate in the machinery space shall not be less than that of the inner bottom plating within the area in question.

6.3.2.10 The thickness of the sump walls and bottom shall be greater by at least 2 mm than that of the watertight floors within the area in question.

6.3.2.11 The thickness of floors, longitudinal girders and inner bottom plating forming boundaries of sea chest shall be increased by at least 2 mm in respect of the minimum thickness required for double bottom structure (including outer bottom plating), or the thickness required in 13.4.2, whichever is the greater. The strength of chest walls shall not be less than the local strength assumed for the outer plating arranged in a given portion of the ship.

6.3.3 Double Bottom Stiffeners

6.3.3.1 The scantlings of longitudinal and transverse frames in the outer and inner bottom shall be determined in accordance with the requirements specified in 13.5.

6.3.3.2 The scantlings of the outer bottom frames in the forebody shall be additionally checked for the action of slamming pressure in accordance with the requirements specified in 6.7.3.

6.3.3.3 When determining the scantlings of double bottom frames, it should be taken into account that vertical struts fitted between longitudinal or transverse frames of the inner and outer bottom are normally not regarded as the effective support of the frames in question. Where the vertical struts are applied, the section modulus for bottom frames may be reduced after special consideration by PRS. Where the stiffeners of the outer and inner bottom have the same section modulus, then a strut fitted in midst of their span may be considered for reduction of section moduli of stiffeners but by not more than 35%. See also 13.7.4.

6.3.3.4 The supporting plates or transverse stiffeners and end brackets shall be fitted on the inner and outer bottom plating between duct girders at every frame (and spaced not more than 0.9 m). The height of a bracket shall not be less than that of the stiffener. The scantlings of supporting plates or stiffeners shall be determined from zone strength analysis of the double bottom (see Chapter 14). Guidelines given in *Publication 18/P – Zone Strength Analysis of Bulk Carrier Hull Structure* may be also taken into consideration.

6.3.4 Double Bottom Primary Supporting Members

6.3.4.1 The scantlings of the girders and plate floors of double bottom shall be determined according to 13.6. Their thickness in the fore peak shall not be less than:

$$t = 12 s + t_k \quad [\text{mm}] \quad (6.3.4.1)$$

s – spacing of girder or plate floor, [m];

t_k – corrosion addition – see 2.5.

The scantlings of double bottom primary supporting member webs in the fore part of the ship shall additionally comply with the requirements of sub-chapter 6.7.4.

6.3.4.2 Plates and stiffeners of double bottom primary supporting members forming bottom tank boundaries shall also comply with the requirements regarding the scantlings of plating and stiffeners of tank bulkheads.

6.3.5 Stiffeners of Double Bottom Primary Supporting Members

6.3.5.1 Stiffeners shall be fitted at every floor within $x > 0.25L_0$ and at every floor of the height exceeding 900 mm outside this area.

For longitudinal framing, the stiffeners shall be applied in line with each longitudinal, whereas for transverse framing, the stiffener spacing shall not be greater than 1.5 m (see also 13.5.3.6).

6.3.5.2 In the double bottom with transverse framing, longitudinal girders shall be stiffened at every frame.

For longitudinal framing, floors shall be stiffened at each longitudinal. See also 6.2.7 and 13.5.3.6. Longitudinal girders shall comply with the requirements for buckling strength specified in Chapter 13.

6.3.6 Supporting Plates in Double Bottom

6.3.6.1 The thickness of the supporting plates fitted at the bottom centre girder, duct girders, side girders and at the margin plate being part of open floors shall not be less than that determined according to 13.2.2.

6.3.6.2 The thickness of the supporting plates not being part of open floors, provided in accordance with the requirements specified in sub-chapter 6.2.7, shall not be less than that of plate floors within the area in question.

6.3.6.3 The breadth of the supporting plates of open floors measured on the inner bottom level shall not be less than 0.75 of the bottom height in way of centre girder, duct girder and margin plate and not less than 0.35 of the bottom height in way of side girders. Where frames of an open floor are not continuous in way of side girder, the supporting plates shall be fitted on both sides of the girder.

6.3.6.4 The free edge in a supporting plate shall be stiffened by a face plate or a flange of the width equal to 10 times the plate thickness shall be applied; the flange width need not exceed 90 mm.

6.4 Single Bottom Structural Arrangement

6.4.1 General Requirements

6.4.1.1 Where single bottom is fitted over a part of the ship, the requirements of sub-chapter 6.2.9 shall be complied with.

6.4.2 Framing System

6.4.2.1 It is recommended that single bottom in ships with the length $L_0 > 90$ m shall be longitudinally stiffened.

6.4.2.2 If the single bottom is longitudinally stiffened, the bottom longitudinals shall comply with the requirements regarding continuity, specified in 6.2.2.2.

6.4.3 Arrangement of Bottom Girders

6.4.3.1 Centre girder shall be fitted in the ship's centre plane. It shall extend fore and aft as far as practicable. The centre girder shall be continuous within $-0.3L_0 \leq x \leq 0.3L_0$.

6.4.3.2 Side girders shall be fitted at the distance not exceeding 2.5 m. It is recommended that they should be continuous when passing through transverse bulkheads within $-0.3L_0 \leq x \leq 0.3L_0$.

6.4.3.3 Girders in the machinery space shall be fitted in compliance with the location of the engine and other main gear seatings.

6.4.4 Arrangement of Floors

6.4.4.1 Within machinery space area, the floors shall be fitted at each frame.

6.4.4.2 In the transversely stiffened bottom, the plate floors shall be fitted at each frame, over the whole length of the ship.

6.4.4.3 In the longitudinally stiffened bottom, the arrangement of plate floors outside machinery space and the ship ends shall be determined on the basis of local and zone strength requirements.

6.5 Scantlings of Single Bottom

6.5.1 Single Bottom Depth

6.5.1.1 The height of centre girder and the attached plate floors shall not be less than that determined by the formula:

$$h = 0.055 B_1 \quad [\text{m}] \quad (6.5.1.1)$$

B_1 – breadth of compartment under consideration measured in the middle of its length in the following way:

- a) for single sides – as the distance between sides or as the distance between the side and longitudinal bulkhead at the level of the upper edge of floor,
- b) for double sides – as the distance between the inner sides or as the distance between the inner side and longitudinal bulkhead.

6.5.1.2 The height of floors in the centre plane may be reduced by 10%, provided that the floor section modulus is not less than that required in 6.5.3.4. The height of floors at the distance of $3/8$ of the ship breadth from the centre plane shall be at least 50% of the height required in the centre plane. In special cases, PRS may accept a departure from this requirement.

6.5.1.3 In ships with one propeller, upper edges of floors in the after peak shall be arranged above the shaft tube.

6.5.2 Single Bottom Plating

6.5.2.1 The requirements of paragraphs 6.3.2.1 to 6.3.2.6, specified for double bottom, shall be complied with.

6.5.3 Girders and Bottom Frames

6.5.3.1 The scantlings of bottom longitudinals shall be determined in accordance with 13.5.

6.5.3.2 The scantlings of bottom frames in the forebody shall be additionally checked for the action of slamming pressure according to 6.7.

6.5.3.3 For longitudinal stiffening system of the bottom, the scantlings of floors and girders shall be determined on the basis of stress analysis in accordance with the requirements of Chapter 14; the requirements of paragraphs 6.5.3.4 to 6.5.3.6 shall be complied with.

6.5.3.4 The section modulus of plate floors in single bottom shall not be less than that determined by the formula:

$$W = K a T_1 B_1^2 \quad [\text{cm}^3] \quad (6.5.3.4)$$

$$K = 7.8 - 0.2B_1;$$

a – floor spacing, [m];

T_1 – ship's draught to the summer load waterline or $0.65H$, whichever is the greater, [m];

B_1 – see 6.5.1.1.

The floor thickness shall be equal to at least 0.01 of their depth in the centre plane plus 3.5 mm, but need not be greater than the bottom plating thickness.

6.5.3.5 The thickness of the centre girder plate in the midship part of the ship shall not be less than that determined by the formula:

$$t = 0.06 L_0 + 6 \quad [\text{mm}] \quad (6.5.3.5)$$

The thickness of the bottom centre girder within $0.1L_0$ from the perpendiculars (forward and after) may be by 1 mm less than that required in the midship part of the ship.

6.5.3.6 The thickness of the bottom side girders plates in the midship part of the ship shall not be less than that determined by the formula:

$$t = 0.06L_0 + 5 \quad [\text{mm}] \quad (6.5.3.6)$$

The thickness of the bottom side girders within $0.1L_0$ from the perpendiculars (forward and after) may be by 1 mm less than that required in the midship part of the ship but shall not be less than 5 mm.

6.5.4 Stiffeners of Single Bottom Floors and Girders

6.5.4.1 Primary supporting member flanges in the single bottom shall have the following scantlings:

- a width not less than $1/20$ of the distance between tripping brackets or 75 mm, whichever is the greater,
- a thickness not less than $1/30$ of the flange width when the flange is symmetrical, and not less than $1/15$ of the flange width when the flange is asymmetrical; in each case the thickness shall be not less than the primary supporting member plate thickness.

6.5.4.2 Cross-sectional area of floor face plates with the minimum height determined in accordance with formula 6.5.1.1 shall not be less than:

- in way of machinery space $A = 5.0T$ [cm²] (6.5.4.2-1)
- outside machinery space $A = 3.5T$ [cm²] (6.5.4.2-2)

6.5.4.3 Floor face plates may be replaced by flanges, provided their section modulus is increased by 5%. The flange width shall comply with the requirements specified in paragraph 6.5.4.1. Flanged floors shall not be applied in way of machinery space, in after peak; in ships with $L_0 > 30$ m also within $0.25 L_0$ from the forward perpendicular.

6.5.4.4 The scantlings of the floors and longitudinal web stiffeners, as well as their arrangement shall comply with the requirements of sub-chapter 3.6.

6.5.5 Bar Keel

The scantlings of a bar keel shall not be less than:

- depth: $h = 100 + 5L_0$ [mm] (6.5.5-1)
- thickness: $t = 10 + 0.6L_0$ [mm] (6.5.5-2)

6.6 Common Requirements for Ships with Single and Double Bottom

6.6.1 Arrangement of Primary Supporting Members in Peaks

Longitudinal or transverse frames in fore and after peaks shall be supported by plate floors or longitudinal girders, respectively, spaced not more than 1.8 m. These primary supporting members shall be supported by heavy intersecting members or bulkheads arranged at distances not greater than $0.125B$ or 5 m, whichever is the lesser.

6.6.2 Complex Primary Supporting Member Systems in Bottom

Where the bottom primary supporting members are connected with primary supporting members of other structures (e.g. side or bulkhead primary supporting members) forming thereby a complex primary supporting member system, their scantlings may be required to be checked on the basis of stress analysis in accordance with the requirements of Chapter 14.

6.6.3 Bilge Keels

A bilge keel shall be attached to the plating by the intermediate member (flat bar) over the full length of the bilge keel.

Weld connection of the bilge keel to the intermediate member shall be weaker than that of the connection of the member to the shell plating.

Bilge keel ends shall be smoothly tapered or rounded and shall be in line with the inner stiffenings of the hull.

6.7 Bottom Strengthening in the Forebody

6.7.1 General Requirements

The bottom forward shall be strengthened against slamming in accordance with the requirements specified below.

6.7.2 Bottom Plating Thickness

6.7.2.1 In ships of length $L_0 \geq 100$ m, the thickness of bottom plating below the waterline at $d = 0.05T_{bd}$ above the keel shall not be less than:

$$t = 0.9 k_u k_r s \sqrt{\frac{p_u}{k}} + t_k \quad [\text{mm}] \quad (6.7.2.1-1)$$

$$k_u = \left(1.1 - 0.25 \frac{s}{l}\right)^2; \quad 1.0 \geq k_u \geq 0.72 \text{ shall be taken;}$$

$$k_r = \left(1 - 0.5 \frac{s}{r}\right) - \text{correction factor for curved plates;}$$

r – plate curvature radius, [m];

p_u – slamming pressure, determined in accordance with 6.7.5, [kPa];

T_{bd} – as in 6.7.5, [m];

s – spacing between stiffenings measured along the plating, [m];

l – span of stiffener or primary supporting member, [m];

t_k – corrosion addition – see 2.5, [mm].

For ships of length $L_0 < 100$ m, the bottom plating thickness shall not be less than:

$$t = 0.9 s \sqrt{p_u} + t_k \quad [\text{mm}] \quad (6.7.2.1-2)$$

6.7.2.2 Above the waterline defined in 6.7.2.1, the plating thickness shall be gradually changed from the thickness determined in 6.7.2.1 to the thickness of the side plating in the hull cross-section under consideration.

6.7.3 Scantlings of Stiffeners

6.7.3.1 The section modulus of the bottom longitudinals or floors supporting the bottom plating defined in 6.7.2.1 and 6.7.2.2, after deduction of corrosion allowances, shall not be taken less than:

$$W = \frac{0.2 l^2 s p_u}{k} \quad [\text{cm}^3] \quad (6.7.3.1)$$

p_u – slamming pressure, determined in accordance with 6.7.5, [kPa].

For the remaining symbols, see 6.7.2.1.

6.7.3.2 Cross-sectional area of the frame web shall not be less than:

$$A_s = \frac{0.03}{k} (l - s) s p_u + 10 h t_k \quad [\text{cm}^2] \quad (6.7.3.2)$$

p_u – slamming pressure, determined in accordance with 6.7.5, [kPa];

h – stiffener height, [m].

For the remaining symbols, see 6.7.2.1.

6.7.4 Primary Supporting Member Webs

6.7.4.1 Net weld connection area of the continuous stiffeners with primary supporting members shall satisfy the formula:

$$2A_s \leq 1.7A_{pm} + A_{ps} \quad (6.7.4.1)$$

A_{pm} – connection area at flange, [cm²];

A_{ps} – connection area at web, [cm²];

A_s – see 6.7.3.2.

6.7.4.2 In the double bottom below the waterline at $d = 0.05 T_{bd}$ above the keel, the spacing of stiffeners on web plates or bulkheads near the shell plating shall not exceed:

$$s_u = 0.09t \quad [\text{m}] \quad (6.7.4.2)$$

t – thickness of web or bulkhead plating, [mm].

6.7.4.3 The sum of cross-sectional shear areas at the ends of primary supporting member or primary supporting member system supporting any specified area of the bottom shall not be less than:

$$\sum A_i = \frac{c_3}{k} l_w b_w p_u \quad [\text{cm}^2] \quad (6.7.4.3-1)$$

p_u – slamming pressure, taken according to 6.7.5, in the middle of the primary supporting member system area considered, [kPa];

l_w, b_w – length and breadth of the loaded area supported by the primary supporting member or the primary supporting member system, [m];

$$c_3 = 0.05 \left(1 - \frac{10 l_w b_w}{L_0 B} \right), \text{ but not less than } 0.025. \quad (6.7.4.3-2)$$

6.7.5 Slamming Pressure

Design slamming pressure imposed on the bottom plating in way of the forebody shall be determined from the following formulae:

– for ships of length $L_0 < 100$ m:

$$p_u = 300 \sqrt{L_0} \left(1 - 20 \frac{T_{bd}}{L_0} \right) \quad [\text{kPa}] \quad (\text{but not less than } p_u = 0 \text{ [kPa]}) \quad (6.7.5-1)$$

– for ships of length $L_0 \geq 100$ m:

$$p_u = \frac{C_1 C_2}{T_{bd}} B_{bd} \left(0.56 - \frac{L_0}{1250} - \frac{u}{L_0} \right) \quad [\text{kPa}] \quad (6.7.5-2)$$

$$C_1 = \sqrt[3]{L_0} \quad \text{for } L_0 < 150 \text{ m} \quad (6.7.5-3)$$

$$C_1 = \sqrt[3]{225 - 0.5 L_0} \quad \text{for } L_0 \geq 150 \text{ m} \quad (6.7.5-4)$$

$$C_2 = 1675 \left(1 - \frac{20 T_{bd}}{L_0} \right) \quad (6.7.5-5)$$

T_{bd} – design heavy weather ballast draught at *F.P.*, [m];

B_{bd} – breadth of the bottom at the waterline positioned at $z = 0.15 T_{bd}$ above the keel measured at the cross-section considered, [m]; B_{bd} shall not be taken greater than $1.35 T_{bd}$ or $0.55 \sqrt{L_0}$, whichever is the lesser;

u – distance from *F.P.* to the considered cross-section of the hull, [m]; the assumed value of u need not be less than u_1 :

$$u_1 = \left(1.2 - \sqrt[3]{\delta} - \frac{L_0}{2500} \right) L_0 \quad [\text{m}] \quad (6.7.5-6)$$

For ships of length $L_0 < 100$ m, the pressure p_u determined from formula 6.7.5-1 shall be applied to $x > 0.3L_0$. From the hull section $x = 0.3L_0$ aft, this pressure may be reduced linearly to zero at $x = 0.1L_0$. For ships of length $L_0 \geq 100$ m, the assumed distribution of slamming pressure p_u acting on the bottom, is shown in Fig. 6.7.5.

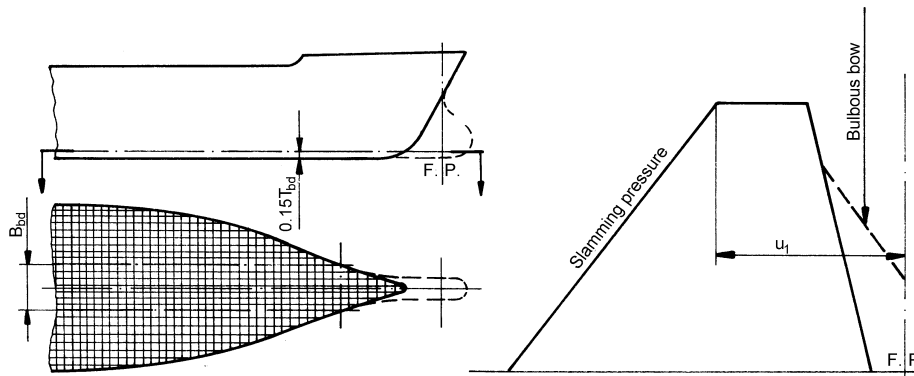

Fig. 6.7.5. Distribution of slamming pressure acting on the bottom

If the ship at the design ballast draught T_{bd} is intended to have full ballast tanks in the forebody and the load from the ballast will act on the shell plating, the slamming pressure may be reduced by $14h$ [kPa]

(h – height of the ballast tank, [m]).

7 SIDE STRUCTURES

7.1 General

7.1.1 Application

The requirements specified in the present Chapter apply to the ship's side structure according to the definition given in 1.2.5.

7.1.2 Span of Main Frames

The lower span of the frame in way of longitudinally stiffened single bottom (see Fig. 7.1.2) shall be determined by the formula:

$$l = l_1 - 0.3r - 1.5(w - h) \quad [\text{m}] \quad (7.1.2)$$

l_1 – vertical distance between the bottom and the lowest deck or side stringer supporting frames [m];

r – bilge radius [m];

w – the largest depth of bilge bracket measured perpendicularly to the flange [m];

h – height of frame [m].

In other cases, the span of frames shall be taken in accordance with 3.2.1.

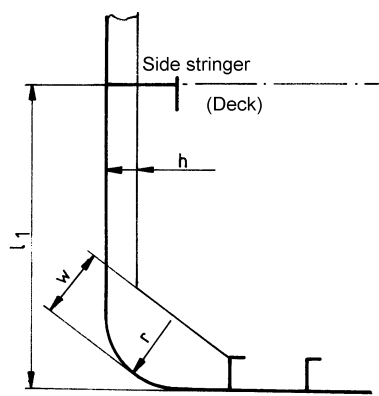

Fig. 7.1.2. Lower span of side frame in way of single bottom

7.1.3 Arrangement of Oil Fuel Tanks

If aggregate capacity of the ship's oil fuel tanks amounts to 600 m³ and above, the oil fuel tanks in double side or nearby shall be arranged so that the requirements of Regulation 12A of Annex I to *MARPOL Convention 73/78* are complied with:

Where oil fuel tanks are necessarily located adjacent to or within machinery spaces of category A, at least one of their vertical sides shall be contiguous to the machinery space boundaries and the area of the tank boundary common with the machinery spaces shall be kept to a minimum – see oil fuel tank arrangements in Figure 7.1.3-1 (additionally, the requirements of *MARPOL 73/78*, Annex I, Regulation 12 A shall be met).

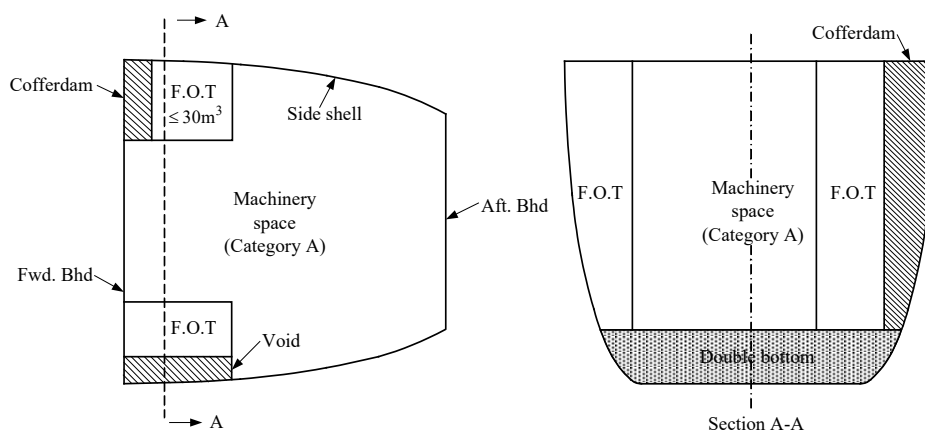

Fig. 7.1.3-1. Oil fuel tanks adjacent to machinery space

7.2 Structural Arrangement

7.2.1 Framing System

It is recommended that longitudinal stiffeners should be used near bottom and strength deck in ships with the length $L_0 > 150$ m.

Within $-0.25L_0 \leq x \leq 0.25L_0$, $0 < z \leq 0.15H$, as well as within $-0.25L_0 \leq x \leq 0.25L_0$, $0.85H < z \leq H$, continuity of longitudinals shall be maintained as required for bottom and deck longitudinals (see 6.2.2.2. and 8.2.2).

7.2.2 Side Primary Supporting Members

7.2.2.1 In the after peak, machinery space and boiler room, side structure shall be strengthened by means of web frames at spacings not exceeding 5 frame spaces.

7.2.2.2 Transverse bulkheads or web frames connected to deck transverses shall be fitted in 'tween deck spaces to ensure adequate transverse rigidity.

7.2.2.3 In the fore peak below the deck arranged above the summer load waterline, platforms or side stringers and rows of stiffeners (panting beams) shall be fitted. The distance between side stringers or platforms (measured vertically) shall not exceed 2 m.

7.2.3 Openings in Side Shell

7.2.3.1 No openings shall be arranged in the sheer strake and in way of plating exposed to high shear stress. Round openings for side scuttles or for other purposes may be arranged within the area considered, if necessary. The openings shall have edge reinforcement in accordance with the requirements specified in 3.5.2.

7.2.3.2 Openings in side shell shall be located more than twice the opening breadth below strength deck or termination of rounded sheer strake. The openings shall comply with the requirements specified in sub-chapter 3.5.

7.2.3.3 The requirements of *Part III, Chapter 7 of the Rules* (SOLAS II-1, Part B-2, Reg.13) concerning openings in the shell plating shall be complied with.

7.2.4 Double Side Ballast Tanks

For double side ballast tanks, recommendations given in IMO MSC/Circ.1021 shall be taken into account within the scope analogous to that for double bottom tanks, specified in 6.2.1.2 and 6.2.8.1.

7.3 Scantlings of Structural Members

7.3.1 Plating

7.3.1.1 The thickness of the side plating shall be determined in accordance with the requirements specified in 13.2 and 13.4.

7.3.1.2 In ships of $L_0 \geq 100$ m, within the below-specified region, the thickness of the side plating shall also be not less than:

$$t = 4s^4 \sqrt{\frac{D}{k^2 L_0}} + t_k \quad [\text{mm}] \quad (7.3.1.2)$$

s – spacing of frames supporting the side plating, [m];

D – displacement of ship at draught T , [t].

The region in question extends between a section aft of amidships where the breadth at the load waterline exceeds $0.9B$ and a section forward of amidships where the load waterline breadth exceeds $0.6B$ and has been taken from the lowest ballast waterline to $z = T + z_0$ [m]; ($z_0 = 0.25T$ but not less than 2.3 m).

7.3.1.3 The thickness of the side plating in the forebody shall be checked additionally for slamming pressure in compliance with the requirements of sub-chapter 7.4.2, if applicable.

7.3.2 Sheer Strake at Strength Deck

7.3.2.1 The breadth of the sheer strake shall not be less than that determined by the formula:

$$b = 800 + 5L_0 \quad [\text{mm}] \quad (7.3.2.1)$$

but need not exceed 1800 mm.

7.3.2.2 The thickness of the sheer strake within $-0.25L_0 \leq x \leq 0.25L_0$ shall not be less than that determined by the formula:

$$t = \frac{t_1 + t_2}{2} \quad [\text{mm}] \quad (7.3.2.2)$$

t_1 – required side plating thickness, [mm];

t_2 – required strength deck plating thickness, [mm], where $t_2 \geq t_1$.

7.3.2.3 The thickness of the sheer strake within $x \leq -0.4L_0$ and $x \geq 0.4L_0$ may be equal to that of the side plating within this area. Between the midship portion of the ship ($-0.25L_0 \leq x \leq 0.25L_0$) and the extreme portions ($x \leq -0.4L_0$ and $x \geq 0.4L_0$) the thickness varies linearly.

7.3.2.4 Where rounded sheer strake is applied at the strength deck, the curvature radius of cold rolled plates shall not be less than $15t$ (t – plate thickness, [mm]).

7.3.2.5 Where end bulkhead of superstructure is located within $-0.25L_0 \leq x \leq 0.25L_0$ and the superstructure deck forms part of the strength deck, the thickness of sheer strake shall be increased by 30% on each side of this bulkhead, over the lengths not less than the height of the lowest tier of the superstructure.

7.3.3 Stiffeners

7.3.3.1 The scantlings of the transverse side frames in cargo holds, cargo and deep tanks, 'tween decks, machinery space and peaks shall be determined in accordance with sub-chapter 13.5.

'Tween deck frames are the frames between the lowest deck or the lowest side stringers and the uppermost superstructure deck between the collision bulkhead and the after peak bulkhead.

7.3.3.2 When calculating, in accordance with 13.5, the section modulus of main frames with brackets at both ends, the following values of permissible stresses may be used:

$s = 185k$ when external sea pressure p is used;

$\sigma = 165k$ when internal pressure p due to cargo, provisions and ballast is used.

These permissible stresses are applicable if effective brackets are fitted at both ends. The vertical arm length of effective brackets shall not be less than:

$0.12l$ – for the lower bracket,

$0.07l$ – for the upper bracket (l – span of the main frame, [m]).

The length of vertical arm of the lower bracket shall be measured from the upper edge of the floor plate.

Where the length l_w of the free edge of the bracket exceeds $40t$ (t – bracket thickness), a flange or face plate of the width not less than $0.067l_w$ shall be fitted.

7.3.3.3 The section modulus of the main frame, calculated for end parts of the frame taking into account the cross-sectional area of the respective end brackets, shall not be less than that required in 13.5 with l equal to the total span of frame (excluding the end brackets) and with bending moment factor m equal to:

8 – for the lower end of the frame,

10 – for the upper end of the frame.

7.3.3.4 End brackets of main frames may be omitted, provided the frame is carried through the supporting structures and the section modulus, determined in accordance with 13.5 assuming the total span l , is increased by 50%.

7.3.3.5 The section modulus of the main frame shall not be less than that of the 'tween deck frame above.

7.3.3.6 Side frames supporting the hatch end beams shall be reinforced to withstand additional bending moments from deck structure.

7.3.3.7 The section modulus of the 'tween deck frames and peak frames shall not be less than that determined by the formula:

$$W = k_1 \sqrt{\frac{L_0}{k}} \quad [\text{cm}^3] \quad (7.3.3.7)$$

$k_1 = 4.0$ for 'tween deck frames,

$k_1 = 6.5$ for peak frames.

7.3.3.8 Side framing in the forebody shall be checked additionally for slamming pressure in accordance with the requirements specified in sub-chapter 7.4.3, if applicable.

7.3.3.9 The scantlings of the panting beams in the forepeak shall correspond to the requirements specified in sub-chapter 13.7.4.

7.3.4 Tripping Brackets

When the span of frames exceeds 5 m or the flange width is less than $1/20$ of the span, a tripping bracket shall be fitted in the middle of the span. Within $x > 0.35L_0$, except the fore peak, the tripping brackets shall extend to the adjacent frame. The vertical distance between tripping

brackets shall not exceed 2.5 m. The thickness of the bracket shall be equal to frame web thickness or 10 mm, whichever is the lesser.

7.3.5 Simple Primary Supporting Members

7.3.5.1 The scantlings of the web frames and side stringers supporting the frames shall be determined in accordance with sub-chapter 13.5.

7.3.5.2 Cross ties may be regarded as effective supports for web frames when:

- the cross tie extends from side to side, or
- the cross tie is supported by other structures which may be considered sufficiently rigid, or
- the load condition may be considered symmetrical with respect to the cross tie.

7.3.5.3 Cross ties regarded as effective supports for web frame may be taken into consideration when determining the design span of the web frames, provided their arrangement meets the following requirements:

- for web frames with one cross tie:

the cross tie is located $(0.36 \div 0.5) l_w$ from the lower end,

- for web frames with two cross ties:

the lower cross tie is located $(0.21 \div 0.3) l_w$ from the lower end and the upper cross tie is located $(0.53 \div 0.58) l_w$ from the lower end of web frame (l_w – span of web frame measured from the floor to the deck beam, [m]).

Web frames with more than two cross ties or with cross ties not located as given above will be specially considered by PRS.

The cross ties are assumed to be spaced evenly on side stringers.

7.3.5.4 Web frames in the machinery space and in peaks shall have the web height not less than that determined by the formula:

$$h = 2 L_0 l \quad [\text{mm}] \quad (7.3.5.4)$$

The height h need not be greater than:

$$h = 200 l \quad [\text{mm}]$$

l – primary supporting member span, [m].

Primary supporting member flanges within the machinery space shall have a thickness not less than $35l$ [mm].

Primary supporting member flanges shall have a thickness not less than 1/30 of the flange width for symmetrical flanges and not less than 1/15 of the flange width when the flange is asymmetrical.

7.3.5.5 In transverse framing structures – in the region forward of the collision bulkhead and below the deck positioned above the summer waterline – horizontal side stringers shall be arranged. The vertical spacing of these stringers shall not exceed 2 m.

The stringers shall be supported by rows of panting beams. The spacing of beams may be equal to two frame spacings. Intermediate frames shall be connected to stringers by means of brackets. Horizontal arms of brackets shall be of the length equal to at least half the breadth of the stringer webs.

Instead of panting beam rows, side web frames may be adopted. The spacing of the web frames shall not exceed 3 m. In the case of longitudinal side framing, the spacing of web frames shall not exceed 2.4 m.

The required value of the moment of inertia I_α of cross-section of panting beams (with effective plate flange, if provided) shall be determined in accordance with 13.7.3. It may be also calculated using the simplified formula:

$$I_\alpha = 6k_1 T l^2 \text{ [cm}^4\text{]} \quad (7.3.5.5)$$

$$k_1 = \frac{A}{2.4}, \text{ however, not less than 1.0;}$$

A – side plate area supported by the panting beam in question, [m²];

l – span of the panting beam, [m].

7.3.6 Complex Primary Supporting Member System

The scantlings of primary supporting members being part of a complex system may be required to be based on direct stress analysis in accordance with the requirements specified in Chapter 14.

Chapters 18÷25 cover cases applicable to various types of vessels for which the direct stress analysis is required.

7.4 Strengthening of the Forebody

7.4.1 Application

The requirements of the present sub-chapter are applicable to all ships and cover the forebody within $z \geq T$ and $x \geq 0.1 L_0$, with regard to the wave impact pressure.

In general, only ships with length $L_0 \geq 100$ m, greater service speed and large flare in the forebody will require the strengthening to be provided.

7.4.2 Shell Plating

7.4.2.1 The thickness of the shell plating in way of the region in question shall not be less than that determined in accordance with formula 6.7.2.1-1, with impact pressure p_u determined in accordance with 7.4.5.

7.4.2.2 Outside the bow region, the shell plating thickness shall be gradually reduced to the value required outside this region.

7.4.3 Scantlings of Stiffeners

7.4.3.1 The section modulus and cross-sectional area of the stiffener web of side longitudinals and transverse frames shall fulfil the requirements specified in 6.7.3 taking the value of p_u determined in accordance with sub-chapter 7.4.5.

7.4.3.2 Outside the bow region, the scantlings of the stiffeners may be gradually reduced to the value required outside this region.

7.4.3.3 Tripping brackets (see 7.3.4) shall be applied where frame webs are not perpendicular to the side plating.

7.4.4 Other Requirements

7.4.4.1 Webs of web frames, stem horizontal brackets, side longitudinal stringers, decks and bulkheads in the forebody shall have a plate thickness not less than:

$$t = \frac{6.5 + 0.15\sqrt{p_u}}{\sqrt{k}} + t_k \quad [\text{mm}] \quad (7.4.4.1)$$

p_u – pressure calculated in accordance with 7.4.5.

For the remaining symbols, see 7.4.4.4.

7.4.4.2 The spacing of stiffeners on primary supporting member web plates or decks near the shell plating shall not exceed:

$$s_n = 0.09 t \quad [\text{m}] \quad (7.4.4.2)$$

t – thickness of deck plating or primary supporting member web in question, [mm].

7.4.4.3 The net section modulus of primary supporting members in the bow region (after deduction of corrosion allowances) shall not be less than that determined by the formula:

$$W = \frac{0.15l^2 b p_u}{k} \quad [\text{cm}^3] \quad (7.4.4.3)$$

For symbols, see 7.4.4.4.

7.4.4.4 The web cross-section area at each end of a primary supporting member shall not be less than that determined by the formula:

$$A_s = \frac{0.02 l b p_u}{k} + 10 h_w t_k \quad [\text{cm}^2] \quad (7.4.4.4)$$

p_u – pressure determined in accordance with 7.4.5;

h_w – primary supporting member web height [m];

l – primary supporting member span [m];

b – breadth of plating supported by a primary supporting member [m];

t_k – corrosion addition (see 2.5) [mm];

k – material factor.

7.4.5 Impact Pressure

The design impact pressure acting on the forebody side plating shall be determined by the formula:

$$p_u = c(2.2 + 1.5 \operatorname{tg} \alpha) \left(0.4 v \sin \beta + 0.6 \sqrt{L_0} \right)^2 \quad [\text{kPa}] \quad (7.4.5-1)$$

$$c = 0.18(C_w - 0.5h_0), \text{ however, not more than } 1.0; \quad (7.4.5-2)$$

C_w – wave coefficient – see Chapter 17;

h_0 – vertical distance of the point in question from the summer load waterline [m];

L_0 – design length of the ship, but not more than 250 m;

α – flare angle measured in plane perpendicular to the waterline in the point in question – see Fig. 7.4.5;

β – angle measured in the plane of waterline with the point in question, between the centre plane and the line tangent to the plating in the point in question – see Fig. 7.4.5.

The angle α may be determined from the formula:

$$\operatorname{tg} \alpha = \frac{a_1 + a_2}{z_w} \quad (7.4.5-3)$$

for a_1, a_2, z_w – see Fig. 7.4.5.

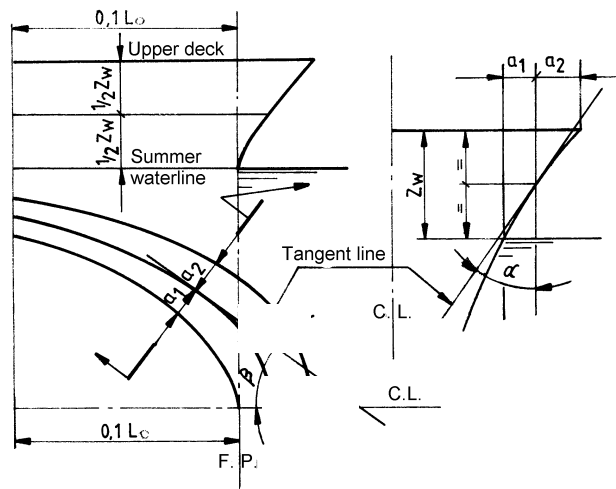

Fig. 7.4.5. Side plating flare angle

Note: If the values of a_1 and a_2 differ considerably, the pressure p_u shall be determined for several waterlines.

8 DECKS

8.1 General

8.1.1 Application

8.1.1.1 The requirements of the present Chapter apply to deck and platform structures according to the definition given in 1.2.4.

8.1.1.2 Additional requirements regarding the decks intended for ro-ro loading are specified in Chapter 19.

8.1.1.3 On ships subject to SOLAS Convention, the applicable requirements of SOLAS II-1, Part B concerning decks shall be complied with.

8.2 Structural Arrangement

8.2.1 Framing System

Dry cargo ships with the length $L_0 > 150$ m shall have deck longitudinals in the strength deck clear of hatchway openings. Transverse system of framing is preferably to be used in deck areas between hatches.

8.2.2 Continuity of Longitudinal Members

When the strength deck is longitudinally stiffened, then:

- in ships with $L_0 \leq 50$ m, the longitudinals may be cut at transverse members and welded thereto over the full length of the ship;
- in ships with $50 \text{ m} < L_0 \leq 150$ m, the longitudinals may be cut at transverse members; in that case continuous brackets crossing the members and connecting the ends of the longitudinals shall be fitted or the structure continuity shall be otherwise provided;
- in ships with $L_0 > 150$, the longitudinals shall be continuous at all transverse members within $-0.25L_0 \leq x \leq 0.25L_0$;
- the longitudinals may be cut at transverse members and welded or connected to them by brackets outside $-0.25L_0 \leq x \leq 0.25L_0$, irrespective of the ship's length.

8.2.3 Deck Structure between Hatches

8.2.3.1 Where deck longitudinals are used in deck areas between hatches, the plate thickness shall be increased or transverse buckling stiffeners shall be fitted intercostally.

8.2.3.2 Transverse beams shall be extended to the second longitudinal from the hatch side. Where this is impracticable, stiffeners or brackets shall be placed intercostally in extension of beams.

8.2.3.3 Stiffening of the upper plane part of a transverse bulkhead or the upper stool plating shall be such that the necessary transverse buckling strength is achieved, where transverse compressive loads, due to the transverse load imposed on the ship's sides, are acting on the deck (see also 8.4.1).

8.3 Scantlings of Structural Members

8.3.1 Plating

8.3.1.1 The thickness of the deck and platform plating shall be determined in accordance with 13.2 and 13.4. In addition, the plating of decks forming boundaries of tanks shall comply with the requirements for watertight bulkheads at heights corresponding to those at which the decks are located.

8.3.1.2 The thickness of the stringer plate in way of the strength deck shall not be less than that of the adjacent deck plating. If the end bulkhead of a superstructure with the deck being the strength deck is located within $-0.25L_0 \leq x \leq 0.25L_0$, the stringer plate thickness shall be increased by 20% for a length of 3 m on each side of the superstructure end bulkhead.

8.3.1.3 The breadth of the stringers plate or strakes in way of longitudinal bulkhead subjected to hull longitudinal bending, which shall be of steel grade B, D or E, shall not be less than that determined by the formula:

$$b = 800 + 5L_0 \quad [\text{mm}] \quad (8.3.1.3)$$

but need not exceed 1800 mm.

8.3.2 Stiffeners

The scantlings of the beams and deck longitudinals of decks and platforms shall be determined in accordance with the requirements specified in 13.5. Additionally, these scantlings shall comply with the relevant requirements for stiffeners of watertight bulkheads in the case of decks and platforms forming tank boundaries.

8.3.3 Scantlings and Arrangement of Deck Primary Supporting Members

8.3.3.1 The scantlings of such simple primary supporting members as: deck stringers, deck transverses and hatchway end beams, as well as hatch coamings regarded as deck primary supporting members, shall comply with the requirements specified in sub-chapter 13.6.

8.3.3.2 The requirements regarding the scantlings of hatch side cantilevers are specified in 8.3.5.

8.3.3.3 Longitudinal primary supporting members in a deck or platform being the top of a tank shall be arranged in line with the vertical primary supporting members of transverse bulkhead.

8.3.3.4 The flange area shall be at least 1/7 of the sectional area of the web plate and the flange thickness shall be at least 1/30 of the flange width.

8.3.3.5 Transverse primary supporting members shall be fitted in the lowest deck in the machinery space in line with web frames. The depth of transverse primary supporting members shall be at least 50% of the height of web frames, whereas the web thickness and face plate scantlings shall be equal to the appropriate scantlings of the web frame.

8.3.4 Complex Primary Supporting Member Systems

The scantlings of primary supporting members being part of complex primary supporting member systems may be required to be based on a direct stress analysis in compliance with the requirements of Chapter 14. The requirements for stress analysis in deck primary supporting members for various types of vessels are given in Chapters 18÷25.

8.3.5 Scantlings of Hatch Side Cantilevers

8.3.5.1 The requirements specified in sub-chapter 8.3.5 apply to the scantlings of hatch side cantilevers, including web frames which may be regarded as simple primary supporting members (see Fig. 8.3.5.1).

The stress analysis according to Chapter 14 shall be carried out where other structural solutions are applied.

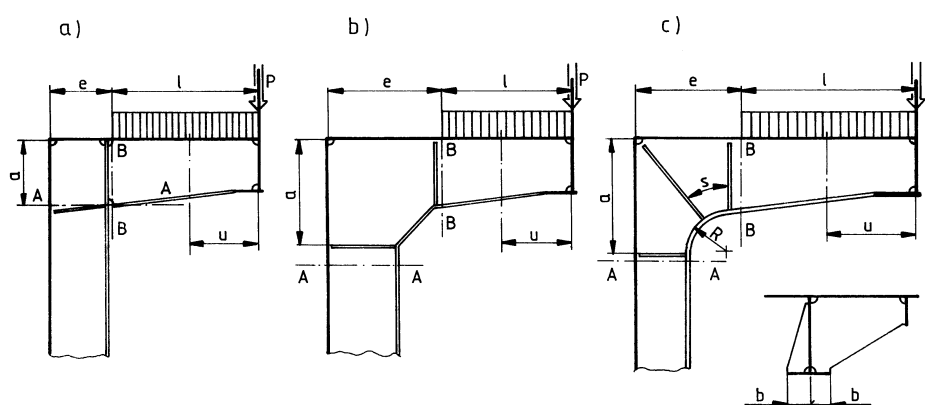

Fig. 8.3.5.1. Hatch side cantilevers

8.3.5.2 For the purpose of the present sub-chapter, the following symbols have been used:

a, e – corner dimensions (see Fig. 8.3.5.1) [m];

b_e – effective breadth of face plate [cm];

b – half of actual face plate breadth [cm];

l – span of hatch side cantilever [m];

P – concentrated force acting in way of intercrossing of the cantilever with the hatch coaming due to the load acting on the hatch cover and on the transversely stiffened deck [kN];

Q – distributed load from cargo acting on longitudinally stiffened deck:

$$Q = plb_0 \text{ [kN];}$$

b_0 – breadth of the loaded area equal to the spacing of cantilevers [m];

p – design pressure due to loading calculated in accordance with Chapter 16 [kPa];

$Q = 0$, for transversely stiffened deck;

u – distance of the considered cantilever cross-section from its end (see Fig. 8.3.5.1) [m].

8.3.5.3 The section modulus of a cantilever and web frame (sections A-A and B-B, see Fig. 8.3.5.1) shall not be less than:

$$W = \frac{6}{k} I (P + 0.5 Q) \quad [\text{cm}^3] \quad (8.3.5.3)$$

8.3.5.4 The effective breadth of flange b_e shall be determined as follows:

– for not rounded connection of the cantilever with the web frame (see Fig. 8.3.5.1 a, b):

$$b_e = 2b \quad [\text{cm}] \quad (8.3.5.4-1)$$

– for the rounded connection of the cantilever with the web frame (see Fig. 8.3.5.1 c):

$$b_e = 2Kb \quad [\text{cm}] \quad (8.3.5.4-2)$$

$$K = 1 - k_1 \left(1 - \frac{2}{c+2} \right) \quad (8.3.5.4-3)$$

- k_1 – coefficient taken from Table 8.3.5.4;
 c – coefficient determined from the formula:

$$c = \frac{b^2}{R t_m} \quad (8.3.5.4-4)$$

- R – radius of curvature, [cm];
 t_m – the flange thickness; $t_m \geq \frac{b}{10}$ [cm] shall be taken.

Table 8.3.5.4
Values of k_1 coefficient

s/b	k_1
$0 < s/b \leq 2$	$0.1 s/b$
$2 < s/b \leq 4$	$0.1 (3 s/b - 4)$
$4 < s/b \leq 8$	$0.05 (s/b + 12)$

s – spacing of stiffeners according to Fig. 8.3.5.1, [cm].

8.3.5.5 The breadth of the effective flange of the deck and shell plating shall be taken as $0.4l$. The assumed breadth shall not be greater than the spacing between the cantilevers and the distance e (see Fig. 8.3.5.1).

8.3.5.6 The net sectional area of the cantilever web shall not be less than:

$$A_s = \frac{0.12}{k} \left(P + Q \frac{u}{l} \right) [\text{cm}^2] \quad (8.3.5.6)$$

8.3.5.7 The thickness of the corner web plate of web frame and cantilever connection in way of the sections A–A and B–B, in Fig. 8.3.5.1, shall not be less than:

$$t = \frac{0.012}{k} (P + 0.5Q) \frac{l}{ae} [\text{mm}] \quad (8.3.5.7)$$

The corner web plate made in compliance with Fig. 8.3.5.1 (a) and (b) shall be additionally strengthened if the dimensions a and e exceed $70t$.

8.4 Additional Requirements

8.4.1 Transverse Strength of Deck between Hatches

In ships with large hatch openings, it shall be checked that the effective deck cross-section area between hatches is sufficient to withstand the transverse load imposed on the ship's sides. Bending and shear stresses may also arise as the result of loading on the transverse bulkhead adjacent to the deck area and also as the result of displacements due to torsion in the hull girder. Reinforcements to reduce the additional stresses will be considered by PRS in each particular case. The effective cross-section area of the deck structure between adjacent hatches is composed of cross-sections areas of:

- deck plating,
- transverse beams,

- transverse deck primary supporting members,
- hatch end beams (after special consideration),
- upper stool of transverse bulkhead,
- transverse bulkhead (plane or horizontally corrugated) down to base of top wing tank or to $0.15H$ from deck, whichever is the lesser.

Corrosion allowances shall be deducted when calculating the effective cross-section area.

The compressive stress shall not exceed $120k$, [MPa] nor 80% of the critical buckling stress of the deck, bulkhead and stool plating. The buckling strength of stiffeners and primary supporting members shall also be checked.

8.4.2 Strengthening at Deck Break

The strengthenings at deck break will be specially considered by PRS in each particular case.

8.4.3 Supporting of Lifting Appliances

8.4.3.1 Masts and columns shall have effective supports and their design shall provide the connection with at least two decks or with one deck and a masthouse of sufficiently strong structure. Masthouses of a standard size and structure in general do not meet the above requirement.

8.4.3.2 The deck shall be sufficiently stiffened and strengthened in those places where standing rigging, guys and topping lifts are fitted.

8.4.3.3 Strengthening of the deck structure by primary supporting members, supported additionally by pillars, if necessary, shall be provided under the longitudinal primary supporting members of seatings of gear arranged on the deck. Those strengthenings will be specially considered by PRS in each particular case.

8.4.4 Supporting of Windlasses

The strength of the supporting structure of windlasses shall be checked. The forces acting on windlasses shall be determined in accordance with sub-chapter 6.3.7, *Part VII – Machinery, Boilers and Pressure Vessels*.

8.5 Openings in Decks

8.5.1 General

8.5.1.1 The width of the openings of single cargo hatches shall not exceed 0.6 of the ship's breadth in way of the opening. Where the opening breadth is greater and in the case of double and triple hatches, the deck structure will be specially considered by PRS with particular attention paid to the hatch corners and their strengthenings.

8.5.1.2 Openings in decks other than hatch openings shall comply with the following requirements:

- as far as practicable, the openings in the strength deck within $-0.3L_0 \leq x \leq 0.3L_0$ and in ships with large hatch openings in way of cargo holds shall be arranged between the hatches;
- the openings in strength deck between the ship's side and line of hatch openings shall be well clear of the hatch corners and side;
- the openings in the remaining areas and decks shall be sufficiently clear of the corners of hatch openings and areas where increased stresses may occur;
- the requirements of sub-chapter 3.5 regarding the performance, arrangement and strengthening of openings shall be complied with.

8.5.2 Hatchway Corners

8.5.2.1 The shape of hatch opening corner within $-0.3L_0 \leq x \leq 0.3L_0$ shall fulfil the following requirements:

- where a corner of circular shape is applied, its radius shall not be less than:

$$R = 0.03 \left(1.5 + \frac{a}{b} \right) (B_1 - b) \quad [\text{m}] \quad (8.5.2.1-1)$$

b – breadth of hatchway, [m];

B_1 – breadth of the ship in way of the considered opening, [m];

a – longitudinal distance between adjacent hatchways (the width of "cross deck structure" between hatchways), [m].

It may be taken that:

$$\frac{a}{b} \leq 1 \quad \text{and} \quad 7.5 \leq (B_1 - b) \leq 15$$

- where a corner with double curvature is applied, the radius may be reduced, the amount of this reduction being specially considered by PRS;
- where a corner of elliptical shape is applied, the transverse extension of curvature shall not be less than that determined by the formula:

$$d_y = 0.025 \left(1.5 + \frac{a}{B_1} \right) (B_1 - b) \quad [\text{m}] \quad (8.5.2.1-2)$$

8.5.2.2 The radius of curvature in hatchway openings in the remaining areas of the strength deck and the second deck located above $0.7H$ may be by 50% less than that calculated in accordance with formula 8.5.2.1-1, however, it shall not be less than 0.2 m.

8.5.2.3 The radius of curvature in hatchway openings on decks and platforms other than those specified above and on the upper deck in ships with $L_0 \leq 40$ m may be equal to 0.15 m.

8.5.3 Deck Strengthening in Way of Hatch Corners

8.5.3.1 Where hatch corners of circular shape are applied, the thickness of deck plates in strength deck shall be increased by 25% in relation to the thickness required for this area.

8.5.3.2 Longitudinal extension of the thicker plating beyond the hatchway edge shall not be less than $1.5R$ in fore and aft direction, whereas the transverse extension shall not be less than $2R$ (for R – see formula 8.5.2.1-1).

8.5.3.3 The butt between the thicker plating at the hatch corner and the thinner plating in the deck area between the hatches shall be located at least 100 mm inside the point at which the curvature of the hatch corner terminates.

8.5.3.4 Where the difference between the normal thickness of deck plate between the hatchways and the thickness of the strengthened plate exceeds 15 mm, a transition plate shall be laid between the thin and thick plating. The quality of steel of the transition plate may be one grade below that of the plating with increased thickness at the hatch corner.

8.6 Coamings

8.6.1 General

8.6.1.1 The requirements regarding the coaming heights are specified in *Part III – Hull Equipment* and are given separately for cargo hatches (sub-chapter 7.10.2), ventilating ducts (sub-chapter 7.7), as well as companionways and skylights (sub-chapter 7.6).

8.6.1.2 Continuous, as well as non-continuous longitudinal hatchway coamings, if extended by continuous longitudinal deck primary supporting members, shall be made of steel of the same strength as the deck structure.

8.6.1.3 The upper edges of the cargo hatchway coamings shall be smooth.

8.6.2 Structure of Cargo Hatchway Coamings

8.6.2.1 Vertical plates of longitudinal coamings shall be extended below the deck to the depth equal to at least the depth of deck beam sections.

Where the longitudinal coaming does not form a part of primary supporting member structure, its part located below the deck shall be extended by at least two frame spacings outside the hatch end beams.

8.6.2.2 Where vertical plates of the hatch transverse coaming are not in line with the hatch end beam, the considered plates shall be extended under the deck by at least three beam spacings outside the longitudinal hatch coamings.

8.6.2.3 Where longitudinal coamings act as deck primary supporting members, they shall be extended under the deck and duly connected to the hatch end beam. The diamond plates shall be fitted in way of junction.

8.6.2.4 Ends of side coamings at the hatchway corners on strength deck shall be bent along the corner curvature and butt welded to the transverse coamings or longitudinal and transverse coamings shall be extended with use of brackets outside the corners.

The brackets shall provide a smooth transition of coamings to primary supporting members under the deck.

8.6.2.5 Where the web plate of a hatch side coaming does not exceed 0.6 m in height, it shall be stiffened with vertical stiffeners at each frame or at spacings of about 60 times the web thickness. Tripping brackets shall be fitted on every second frame and the upper edge of the coaming shall be strengthened by a horizontal stiffener.

8.6.2.6 Hatchway coamings extending 0.6 m and more above the deck shall be stiffened by a horizontal stiffener not more than 0.25 m from the upper edge of the coaming. Where the coaming length exceeds 3 m, coaming brackets shall be fitted at distances not exceeding two frame spacings between the horizontal stiffener and the deck.

Strengthening of coamings with the height exceeding 0.9 m and the coamings of power operated hatch covers will be specially considered by PRS in each particular case.

8.6.3 Scantlings of Hatchway Coamings

8.6.3.1 The scantlings of the coamings acting as deck primary supporting members or hatch end beams shall comply with the requirements specified in 8.3.3.

8.6.3.2 Hatchway coamings of holds intended for ballast or liquid cargo shall satisfy the requirements for the tank bulkheads specified in 9.3.

8.6.3.3 The vertical plate thickness of hatchway coamings in ships with the length $L_0 > 60$ m shall not be less than 11 mm.

8.6.3.4 Stiffeners, brackets and coamings shall be able to withstand the local forces set up by the clamping devices and/or the handling facilities necessary for securing and moving the hatch covers, as well as mass forces from the cargo stowed on the hatch covers (see also *Part III – Hull Equipment*, sub-chapter 7.10).

8.6.3.5 When loading operations are to be performed by means of grabs, the requirements of sub-chapter 26.4 shall be taken into account.

8.6.4 Ventilator Coaming

8.6.4.1 The thickness of the ventilator coamings situated on the freeboard deck and on the exposed superstructure decks within $x \geq 0.25L_0$ shall not be less than that determined by the formula:

$$t = 0.01 d + 5 \quad [\text{mm}] \quad (8.6.4.1)$$

d – internal diameter or the length of the greater side in the case of rectangular coaming, [mm].
The thickness t shall not be less than 7 mm and it need not exceed 10 mm.

The thickness of the coamings situated on the decks of the first tier in superstructures within $x < 0.25L_0$ may be reduced by 10% as compared to that required for the coamings on the freeboard deck.

8.6.4.2 Where the thickness of the deck plating is less than 10 mm, the plate of the length and breadth not less than twice the diameter or twice the length of the greater side of the coaming and of thickness not less than 10 mm shall be provided in way of the coaming.

Where suitable connection between the coamings and deck structure is provided, the above-mentioned plate is not required.

8.6.4.3 Where the ventilator coaming is higher than 900 mm, it shall be connected to the deck by means of brackets.

8.6.5 Coamings of Companion-Hatches and Skylights

The structure of the coamings of companion-hatches and skylights shall be of the strength equivalent to that of cargo hatches; the thickness of coamings shall not be taken less than 7 mm, but need not be greater than that of the deck at the coaming.

8.7 Pillars

8.7.1 Arrangement and Attachment of Pillars

8.7.1.1 The pillar axis in 'tween deck spaces and holds are normally to be fitted in the same vertical line. Deck longitudinal and transverse primary supporting members in way of pillars shall be strengthened.

8.7.1.2 A doubling plate on the inner bottom or deck plating under the heel of a pillar of more than 125 mm in diameter shall be fitted (if the end brackets of the pillar are not provided). The doubling plate shall be welded continuously at its circumference. The thickness of the doubling plate shall not be less than:

$$t = \frac{P}{245} + 10 \quad [\text{mm}] \quad (8.7.1.2)$$

P – nominal axial force in the pillar according to 13.7 [kN].

The diameter of the doubling plate shall be by $6t$ greater than that of the pillar.

8.7.1.3 The ends of heavily loaded pillars and those exposed to considerable dynamic loads, pillars of diameter exceeding 350 mm, as well as all pillars of non-circular cross-section shall be fastened by means of brackets fitted above or under the deck, or in other equivalent way (conical inserts), irrespective of doubling plates, so as to ensure transfer of load between the pillars and to the structure of decks or inner bottom.

8.7.2 Scantlings of Pillars

8.7.2.1 Cross-sectional area of a pillar shall be determined according to 13.7.

8.7.2.2 The thickness of the walls in tubular pillars shall not be less than that determined by the formula:

$$t = \frac{d_z}{50} + 3.5 \quad [\text{mm}] \quad (8.7.2.2)$$

and shall not be less than 6 mm.

d_z – outer diameter of the pillar, [mm].

8.7.2.3 The web thickness of section-built pillars shall not be less than that determined by the formula:

$$t = \frac{h_s}{50} \quad [\text{mm}] \quad (8.7.2.3)$$

and shall not be less than 6 mm.

h_s – height of the cross-section of the pillar web plate, [mm].

8.7.3 Pillars in Tanks

8.7.3.1 Where the hydrostatic pressure may induce the tensile stress in pillars, the pillar sectional area shall not be less than that determined by the formula:

$$A_p = 0.07 F_p p_p \quad [\text{cm}^2] \quad (8.7.3.1)$$

F_p – deck area supported by pillars [m²];

p_p – design pressure giving tensile stress in pillars [kPa].

8.7.3.2 Pillars in tanks shall be made of plates or open sections.

8.7.3.3 End brackets shall be fitted instead of end doubling plates specified in paragraph 8.7.1.2.

8.8 Helicopter Decks

8.8.1 General Requirements

8.8.1.1 The requirements specified in the present sub-chapter apply to ships with helicopter landing areas on weather decks or special platforms.

8.8.1.2 Plans showing the arrangement, scantlings and details of the helicopter deck shall be submitted to PRS for approval. The arrangement plan shall show the overall size of the helicopter deck and the designated landing area.

If helicopter(s) are intended to be stowed on the helicopter deck, the stowage area and the arrangement of equipment securing helicopter(s) to the deck shall be indicated on the arrangement plan.

Also helicopter's technical specification necessary for the calculation of helicopter deck strength such as: maximum weight, span of wheel axes, dimensions of wheel prints, the rotor diameter, shall be provided.

8.8.1.3 The diameter of the landing area shall not be smaller than $4/3$ of maximum rotor diameter of the helicopter to land.

8.8.1.4 The surface of the helicopter deck shall be covered with anti-slippery coating. Decks covered with wood shall be protected against fire.

8.8.1.5 As regards helicopter decks on special platforms, the security nets shall be provided around these platforms.

8.8.1.6 As regards helicopters with landing gear other than wheels – the values of local design loads will be specially considered by PRS.

8.8.1.7 Where justified, corrosion additions shall be taken into account. The value of corrosion additions will be specially considered by PRS.

8.8.1.8 It is recommended that the surface of the helicopter deck should be provided with an appropriate drainage system at the perimeter, taking into account the use of fire-fighting systems and possibility of fuel leakage.

8.8.2 Design Loads

8.8.2.1 The following design loads acting separately on the landing shall be taken into account:

- .1 overall distributed loading: a minimum distributed loading of 2 kPa shall be taken over the entire helicopter deck;
- .2 helicopter landing impact loading: a load of not less than 150% of the helicopter maximum take-off weight shall be taken on two wheel print areas not greater than 0.3 m × 0.3 m;
- .3 where the helicopter deck is arranged on decks of deckhouses or superstructures and the spaces below are normally manned (accommodation spaces, control room, etc.), the impact loading specified above shall be increased by 15%;
- .4 stowed helicopter loading: local loading equal to the manufacturer's recommended wheel loadings at the helicopter maximum take-off weight, increased by a dynamic amplification factor based on the predicted motions of the ship on waves determined according to 16.4.4;
- .5 additionally, if applicable, the loading of 0.5 kPa representing snow or ice shall be taken into account.

8.8.2.2 When calculating the helicopter deck primary supporting members and structural elements supporting the deck (frame members, truss supports etc.), the structural weight of the helicopter deck shall be taken into account by adding suitable values to loadings specified in 8.8.2.1.1, 8.8.2.1.2 and 8.8.2.1.3.

8.8.2.3 Calculations of structural elements shall take into account also wind loadings and wave impact loadings on helicopter decks, where the analysis discloses possibility of their occurrence.

8.8.2.4 The helicopter deck shall be designed for helicopter landings at any location within the designated landing area.

8.8.3 Structure of Helicopter Deck on Special Platforms

8.8.3.1 The thickness of the helicopter deck loaded with overall distributed loading shall be taken not less than the thickness calculated from formula 13.4.2.1-1, where σ shall be taken equal to 140k [MPa]. Additionally, the requirements regarding minimum thickness, specified in 13.2.4, shall be complied with.

8.8.3.2 The thickness of the helicopter deck determined for wheels loadings shall be taken not less than the thickness calculated in accordance with formula 19.4.2, where value of factor K_1 shall be taken equal to 1.075.

8.8.3.3 The scantlings of helicopter deck primary supporting members and structural elements supporting the deck shall be determined on the basis of direct calculations taking into account the requirements specified in 14.3.

The scantlings of the helicopter deck beams resulting from the loading determined in 8.8.2.1.1 may be determined in accordance with 13.5, where σ shall be taken equal to 140k [MPa].

The scantlings of the helicopter deck beams resulting from the loading determined in accordance with 8.8.2.1.2 and 8.8.2.1.3 shall be determined on the basis of direct calculations, taking into account the requirements specified in 14.3.

The values of allowable stresses are specified in Table 8.8.3.3.

Table 8.8.3.3

Values of allowable stresses in structural elements of helicopter decks [MPa]

Loading	Structural elements	
	beams	primary supporting members, pillars, supporting members
acc. to 8.8.2.1.1	$\sigma = 140k$	$\sigma = 120k$, but not more than $0.6\sigma_c$, $\tau = 70k$, $\sigma_e = 140k$,
acc. to 8.8.2.1.2	$\sigma = 225k$ $\tau = 110k$ $\sigma_e = 235k$	$\sigma = 190k$, but not more than $0.9\sigma_c$, $\tau = 110k$, $\sigma_e = 210k$,
acc. to 8.8.2.1.3	$\sigma = 195k$ $\tau = 100k$ $\sigma_e = 210k$	$\sigma = 170k$, but not more than $0.9\sigma_c$, $\tau = 100k$, $\sigma_e = 190k$

Notes:

1. σ_c in Table 8.8.3.3 means the values of critical buckling stresses of pillars, struts or other elements subjected to compression stresses calculated according to the requirements of Chapter 13.
2. Equivalent stresses shall be calculated according to formula 14.4.6. Where beam models are applied for direct calculations, $\sigma_y = 0$ shall be taken.

8.8.3.4 The arrangement of helicopter deck primary supporting members and structural elements supporting the deck shall be adapted to the ship’s hull structure. If necessary, the hull structure shall be provided with additional supports or shall be suitably strengthened.

8.8.4 Structure of Helicopter Deck on Weather Decks

Where the helicopter deck is a part of a weather deck, its structure is subject to PRS consideration in each particular case.

9 BULKHEADS

9.1 General

9.1.1 Application

The requirements of the present Chapter apply to bulkhead structures and their arrangement according to the definition given in 1.2.5.

On ships subject to SOLAS Convention, the applicable requirements for the arrangement and construction of bulkheads, the requirements for bulkhead openings and the requirements for tightness and strength test of bulkheads, contained in SOLAS II-1, Part B-2, shall also be met.

The explanatory notes of *IMO MSC.429(98)/Rev.2* shall be taken into account when considering the watertight bulkheads.

9.1.2 Definitions

L_F = L – ship length defined in 1.2.2, [m].

T_F – ship draught equal to $0.85H_F$, [m].

H_F – the least moulded depth measured to the freeboard deck, [m].

δ_F – hull block coefficient corresponding to T_F draught:

$$\delta_F = \frac{V_F}{L_F B T_F} \quad (9.1.2)$$

FP_F – fore perpendicular defined for L_F waterline.

h_N – height of superstructure, [m].

V_F – moulded volume of submerged part of the ship corresponding to T_F draught, [m].

9.2 Subdivision

9.2.1 General Requirements

9.2.1.1 The requirements of *Part IV – Stability and Subdivision* applicable to subdivision of a hull into watertight compartments shall be complied with.

9.2.1.2 The following transverse watertight bulkheads shall be fitted in all ships:

- collision bulkhead,
- after peak bulkhead,
- bulkheads at each end of the machinery space (the aft bulkhead of this space may also act as an after peak bulkhead) - see resolution *MSC.429(98)/Rev.2* - Revised Explanatory Notes to the SOLAS Chapter II-1 Subdivision and Damage Stability Regulations”.
- bulkheads shall be fitted separating the machinery space from cargo and accommodation spaces forward and aft and made watertight up to the bulkhead deck of passenger ships and the freeboard deck of cargo ships. An afterpeak bulkhead shall also be fitted and made watertight up to the bulkhead deck or the freeboard deck. The afterpeak bulkhead may, however, be stepped below the bulkhead deck or freeboard deck, provided the degree of safety of the ship as regards subdivision is not thereby diminished.

For ships without longitudinal bulkheads, the total number of watertight transverse bulkheads shall not be less than that given in Table 9.2.1.2.

The distance between the adjacent bulkheads shall not exceed 30 m; an increase in this distance will be specially considered by PRS in each particular case.

After special consideration, by PRS, of the hull arrangement and strength, the number of watertight bulkheads may be reduced. Special requirements regarding the number and arrangement of watertight bulkheads, including the requirements of international conventions concerning the number and arrangement of watertight bulkheads, may be applied to particular types of ships.

Table 9.2.1.2
Number of transverse watertight bulkheads

Ship length L_F , [m]	Machinery space	
	Aft ¹⁾	Elsewhere
1	2	3
$L_F \leq 65$	3	4
$65 < L_F \leq 85$	4	4
$85 < L_F \leq 105$	4	5
$105 < L_F \leq 125$	5	6
$125 < L_F \leq 145$	6	7
$145 < L_F \leq 165$	7	8
$165 < L_F \leq 190$	8	9
$190 < L_F \leq 225$	9	10
$L_F > 225$	upon agreement with PRS	

¹⁾ The after peak bulkhead forms the after boundary of the machinery space.

9.2.2 Collision Bulkhead

9.2.2.1 A collision bulkhead shall be fitted which shall be watertight up to the bulkhead deck of passenger ships and the freeboard deck of cargo ships.

For passenger ships, the collision bulkhead shall be situated in accordance with the requirements specified in 19.1.5.4 ÷ 19.1.5.6.

9.2.2.2 The distance l_c from the perpendicular FP_F to the collision bulkhead shall be taken between the following limits:

$$l_1 - l_r \leq l_c \leq l_2 - l_r \quad (9.2.2.2)$$

- $l_1 = 0.05 L_F$ or 10 m, whichever is the lesser;
- $l_2 = 0.08 L_F$ or $0.05 L_F + 3$ [m], whichever is the greater;

where :

- for ships with ordinary bow shape:

$$l_r = 0$$

- for ships having any part of the underwater body extending forward of FP_F , l_r shall be taken as the smallest of:

$$l_r = 0.5 l_b \text{ [m]},$$

$$l_r = 0.015 L_F \text{ [m]},$$

$$l_r = 3.0 \text{ [m]},$$

where l_b is determined as shown in Fig. 9.2.2.2.

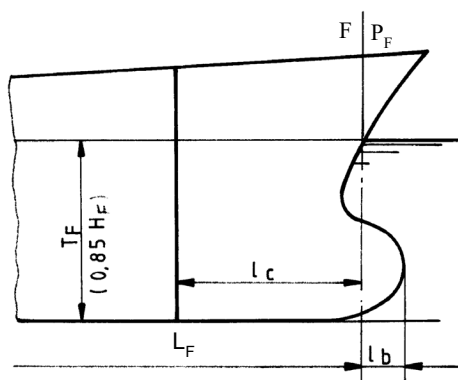

Fig. 9.2.2.2. Position of the collision bulkhead

9.2.2.3 Steps or recesses in the collision bulkhead are also covered by the above requirements.

9.2.2.4 Where bow doors are fitted and a sloping loading ramp forms part of the extension of the collision bulkhead above the bulkhead deck of passenger ships and the freeboard deck of cargo ships the ramp shall be weathertight over its complete length.

In cargo ships the part of the ramp which is more than 2.3 m above the freeboard deck may extend forward of the limit specified in 9.2.2.2 (see Fig. 9.2.2.4).

Ramps not meeting the above requirements shall be disregarded as an extension of the collision bulkhead.

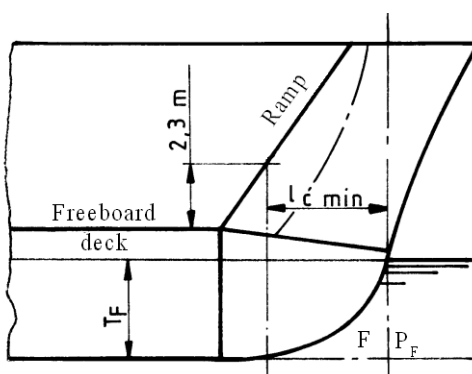

Fig. 9.2.2.4. Collision bulkhead with a ramp

9.2.2.5 Upon agreement with PRS, the distance of the collision bulkhead from $F P_F$ may be increased with respect to that determined in accordance with 9.2.2.2 if damage waterline is in each case below the freeboard deck after flooding the forepeak.

9.2.2.6 No doors, manholes, access openings, ventilation ducts or any other openings shall be fitted in the collision bulkhead below the bulkhead deck of passenger ships and the freeboard deck of cargo ships (see resolution MSC.421(98), Annex, Part B-2, Regulation 12.6.1 and 12.6.2).

9.2.2.7 The number of openings in the extension of the collision bulkhead above the freeboard deck shall be restricted to the minimum compatible with the design and normal operation of the ship. All such openings shall be capable of being closed weathertight.

9.2.3 Vertical Extent of Watertight Bulkheads

9.2.3.1 All watertight bulkheads shall extend to the bulkhead deck of passenger ships and freeboard deck of cargo ships. The afterpeak bulkhead may, however, be stepped below the bulkhead deck or freeboard deck, provided the degree of safety of the ship as regards subdivision is not thereby diminished.

9.2.3.2 For ships with a continuous deck below the freeboard deck and where the draught is less than the depth to the second deck – all bulkheads, except the collision bulkhead, may terminate at the second deck. In such cases, however, the engine casing between the second and upper deck shall be arranged as a watertight structure and the second deck shall be watertight outside the casing above the engine room.

9.2.3.3 Where a long forward superstructure is fitted, the collision bulkhead shall be extended weathertight to the deck next above the bulkhead deck of passenger ships and the freeboard deck of cargo ships. The extension need not be fitted directly above the bulkhead below provided that all parts of the extension, including any part of the ramp attached to it are located within the limits prescribed in 9.2.2.2. with the exception permitted by 9.2.2.4 and that the part of the deck which forms the step is made effectively weathertight. The extension shall be so arranged as to preclude the possibility of the bow door or ramp, where fitted, causing damage to it in the case of damage to, or detachment of, a bow door or any part of the ramp.

9.2.4 Cofferdams

9.2.4.1 Cofferdams shall be arranged to separate:

- fuel tanks of fuel flash point lower than 43°C from accommodation, service and cooled spaces;
- fuel tanks from fresh water tanks lubricating oil and vegetable oil tanks;
- oil tanks from accommodation, service and cooled spaces, as well as fuel and fresh water tanks;
- cargo and slop tanks for fuel of flash point lower than 43°C from service spaces, machinery spaces and boiler rooms, general cargo holds;
- vegetable oil tanks from fuel, lubricating oil and fresh water tanks;
- fresh water tanks from fuel, lubricating oil and vegetable oil tanks.

The width of vertical cofferdams shall not be less than 0.6 m and the height of the horizontal cofferdams not less than 0.7 m, unless specified otherwise. Cofferdams shall be accessible to survey and repairs. The cofferdam forward of the collision bulkhead (forepeak) is not considered as cofferdam.

9.2.4.2 In ships of 400 tonnes gross tonnage and above, compartments forward of the collision bulkhead shall not be used for the carriage of oil or other flammable liquids.

9.2.5 Minimum Bow Height

The minimum bow height shall be determined according to Appendix 7, *Part IV – Stability and Subdivision*.

9.2.6 Construction of watertight bulkheads

9.2.6.1 Each watertight subdivision bulkhead*, whether transverse or longitudinal, shall be constructed having scantlings as specified in subchapter 1.2 (SOLAS II-1/2.17). In all cases, watertight subdivision bulkheads shall be capable of supporting at least the pressure due to a head of water up to the bulkhead deck of passenger ships and the freeboard deck of cargo ships. (SOLAS II-1/10.1)

* Explanatory notes – see MSC.429(98)/Rev.2.

9.2.6.2 Steps and recesses in watertight bulkheads shall be as strong as the bulkhead at the place where each occurs. (SOLAS II-1/10.2)

9.2.6.3 Where openings are provided in watertight bulkheads, they shall be provided with appropriate closures meeting the applicable requirements specified in sub-chapter 7.9, *Part III – Hull Equipment*.

9.3 Structural Arrangement

9.3.1 General Requirements

9.3.1.1 The peak tanks shall have centre line wash bulkheads when the breadth of the tank exceeds $2/3B$.

9.3.1.2 In ships with machinery space situated amidships, a watertight shaft tunnel shall be arranged. The shaft tunnel may be omitted in ships of restricted service – mark **II** or **III** in the symbol of class, provided the shafting is otherwise effectively protected. Bearings and stuffing boxes shall be accessible.

9.3.1.3 In all cases stern tube shall be enclosed in watertight space of moderate volume. In passenger ships the stern gland shall be situated in a watertight shaft tunnel or other watertight space separate from the stern tube compartment and of such volume that, if flooded by leakage through the stern gland, the bulkhead deck will not be immersed. In cargo ships other measures to minimize the danger of water penetrating into the ship in case of damage to stern tube arrangements may be considered by PRS in each particular case (see *MSC.429(98)/Rev.2* – “Revised Explanatory Notes to the SOLAS Chapter II-1 Subdivision and Damage Stability Regulations”).

Moving parts penetrating the shell plating below the deepest subdivision draught shall be fitted with a watertight sealing arrangement acceptable to PRS. The inboard gland shall be located within a watertight space of such volume that, if flooded, the bulkhead deck of passenger ships and the freeboard deck of cargo ships will not be submerged. PRS may require that if such compartment is flooded, essential or emergency devices must remain available in other parts of the ship.

9.3.2 Structure of Longitudinal Bulkheads

Within $-0.25L_0 \leq x \leq 0.25L_0$, in the areas $0.15H$ above the bottom and $0.15H$ below the strength deck, continuity of the bulkhead longitudinals shall be such as is required for the bottom and deck longitudinals, respectively.

9.3.1 Corrugated Bulkheads

9.3.2.1 Transverse and longitudinal tank and hold bulkheads may be corrugated.

The lower and upper parts of longitudinal bulkheads shall be plane for a distance not less than $0.13H$ measured from the bottom and deck, respectively.

The transverse corrugated bulkheads with vertical corrugations shall be plane for a distance not less than $0.08B$ measured from the ship sides.

Horizontal primary supporting members shall be applied where span of a vertical member in a corrugated bulkhead exceeds 15 m.

9.3.2.2 Design spacings of stiffenings in corrugated bulkheads are assumed as follows (see Fig. 9.3.3.2):

– for plate thickness calculation, the greater of the values:

- $s = 1.05 s_2$ or $s = 1.05 s_3$, [m] – in general,
 $s = s_2$ or $s = s_3$, [m] – where the web plates are perpendicular to the attached plating;
 – $s = s_1$ for section modulus calculations.

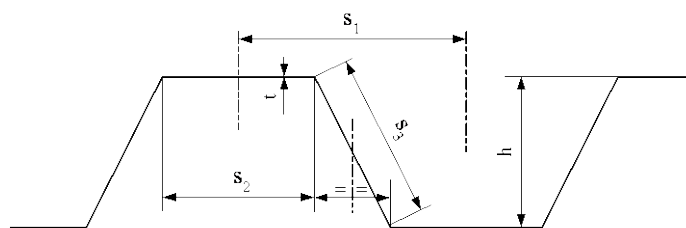

Fig. 9.3.3.2. Corrugated bulkhead

9.4 Scantlings of Structural Members

9.4.1 Plating

9.4.1.1 The thickness of the plating in watertight, wash and tank bulkheads shall be determined in accordance with the requirements specified in 13.2 and 13.4.

9.4.1.2 The plating thickness of the after peak bulkhead shall be increased in way of shaft stuffing box.

9.4.1.3 Unless buckling strength is proved satisfactory by the direct stress analysis, the following requirements apply to corrugated bulkheads:

$$t = \frac{s_2}{0.05} \quad [\text{mm}] \quad \text{if} \quad \frac{s_2}{s_3} = 0.5 \quad (9.4.1.3-1)$$

$$t = \frac{s_2}{0.07} \quad [\text{mm}] \quad \text{if} \quad \frac{s_2}{s_3} \geq 1.0 \quad (9.4.1.3-2)$$

(for s_1, s_2 – see Fig. 9.3.3.2).

The minimum required values of thickness t for intermediate values s_2/s_3 shall be obtained by linear interpolation.

Where section modulus of corrugated bulkhead is greater than the required value, the bulkhead thickness may be reduced by multiplying the required thickness by the following factor:

$$\sqrt{\frac{W_{\text{required}}}{W_{\text{actual}}}} \quad (9.4.1.3-3)$$

9.4.1.4 The plating thickness of a wash bulkhead may be required to be based on the reaction forces imposed on the bulkhead by the adjacent structures.

9.4.2 Stiffeners

9.4.2.1 The scantlings of the vertical and horizontal stiffeners and of the elements of corrugated bulkheads shall be determined in accordance with 13.5.

9.4.2.2 Stiffeners transferring the axial compression loadings shall comply with the requirements specified in sub-chapter 13.7.3.

9.4.2.3 In cargo holds intended for the carriage of bulk cargo or ballast, the scantlings of vertical corrugations of corrugated bulkheads or structural members of double plane transverse

bulkheads, having unsupported spans (from bottom to deck) shall be determined from stress analysis, taking into account the reactions from the double bottom and deck structures. The above requirement covers also the box structures (stools) applied at bottom or deck.

9.4.3 Simple Primary Supporting Members

The scantlings of the horizontal and vertical primary supporting members in longitudinal and transverse bulkheads shall be determined in accordance with the requirements specified in 13.6. Where the bulkhead primary supporting members transfer the axial compression loadings, the scantlings of their members shall comply with the requirements specified in sub-chapter 13.7.3.

9.4.4 Complex Primary Supporting Member Systems

The scantlings of the bulkhead primary supporting members being part of complex primary supporting member systems may be required to be based on a stress analysis in accordance with the requirements specified in Chapter 14. Cases where the stress analysis for bulkhead primary supporting members is necessary are specified for various types of ships.

9.5 Additional Requirements

9.5.1 Shaft Tunnel

9.5.1.1 The scantlings of the shaft tunnel primary supporting members shall comply with the requirements applied to bulkheads, but the thickness of the curved top plating may be taken as 90% of that required for the plane plating with the same stiffener spacing.

9.5.1.2 If ceiling is not fitted on the tunnel top plating under dry cargo hatchway openings, the thickness shall be increased by 2 mm.

9.5.2 Supporting Bulkheads

9.5.2.1 Bulkheads supporting decks shall be regarded as pillars and shall comply with the requirements specified in sub-chapter 13.7.3. The radius of gyration of the stiffener cross-section shall be calculated including the effective flange width of bulkhead plating equal to $40t$ (t – bulkhead plate thickness).

9.5.2.2 The plate thickness shall not be less than 7.5 mm in the hold and 6.5 mm in ‘tween decks.

9.5.2.3 The depth of corrugations on corrugated bulkheads shall not be less than 150 mm in holds and 100 mm in ‘tween decks.

9.5.3 Construction of Watertight Decks, Tunnels, Duct Keels and Ventilators

9.5.3.1 Watertight decks, trunks, tunnels, duct keels and ventilators shall be at least of the same strength as watertight bulkheads at corresponding levels.

9.5.3.2 Watertight ventilators and trunks shall be carried out at least up to the bulkhead deck in passenger ships and up to the freeboard deck in cargo ships.

9.5.3.3 Where a ventilation trunk passing through a structure penetrates the bulkhead deck, the trunk shall be capable of withstanding the water pressure that may be present within the trunk in assumed damage conditions (according to *Part IV – Stability and Subdivision*) after having taken into account the maximum heel angle allowable during intermediate stages of flooding. Where the ventilation trunk scantlings are analogous to the scantlings of watertight bulkheads, such structure is considered as having sufficient strength.

10 SUPERSTRUCTURES

10.1 General

10.1.1 Application

The requirements specified in the present Chapter apply to superstructure end bulkheads, deckhouse sides and ends, casings and bulwarks.

Sides of superstructures are covered by the requirements specified in Chapter 7, whereas decks of deckhouses and superstructures are covered by the requirements specified in Chapter 8.

10.1.2 Explanations

Long deckhouse – deckhouse having not less than $0.2L_0$ of its length within $0.4L_0$ amidships.

Short deckhouse – deckhouse that cannot be defined as a long deckhouse.

Tier – space between the successive decks of a superstructure or deckhouse; tiers are counted from the upper deck.

10.1.3 Definitions

l – stiffener span [m], determined in accordance with the requirements specified in 3.2.1;

s – stiffener spacing [m];

p – design pressure [kPa].

10.2 Structural Arrangement

10.2.1 Structural Continuity

10.2.1.1 In superstructures and deckhouses, particularly those situated aft, the front bulkhead shall be in line with a transverse bulkhead below the deck or shall be supported by a combination of partial transverse bulkheads, girders and pillars. The after end bulkhead shall also be effectively supported. As far as practicable, exposed sides and internal longitudinal and transverse walls shall be located in line with tank bulkhead or girders in the hull structure and shall be in line in successive tiers of erection. Where such structural arrangement in line is not possible, other effective support shall be applied.

10.2.1.2 Sufficient transverse strength and stiffness of superstructures and deckhouses shall be provided by means of transverse bulkheads or girder structures at spacings not exceeding 10 m.

10.2.1.3 Where sides of the superstructure are in line with ship's sides, the plating of the sides shall be extended beyond the end bulkhead of the superstructure and shall transit smoothly to the sheer strake. The transition shall be free of local discontinuities. A substantial stiffener shall be fitted at the free edge of plating or below it at a distance not more than 50 mm from the extended side plating of the superstructure. The plating shall also be additionally stiffened.

In general, openings shall not be located in the extended superstructure plating. The superstructure plating shall not be connected with the bulwark.

10.2.1.4 Openings in the sides of long deckhouses shall have well rounded corners. Horizontal stiffeners shall be fitted at the upper and lower edge of window openings.

Door openings in the sides shall be stiffened along the edges. Plate panels below and above the doors shall be continuous and their thickness shall be increased.

10.2.1.5 Cross-sectional area of welds connecting deckhouse corners with deck plating shall be increased with respect to that normally required. Corners of long deckhouses situated on the strength deck shall have radius of curvature calculated by the formula:

$$R = 0.02 l_p \quad [\text{m}] \quad (10.2.1.5)$$

l_p – length of deckhouse, [m].

The assumed value of R need not be greater than 1.4 m.

10.2.1.6 If sides of long deckhouses are not in line with longitudinal bulkheads or girders, but are supported by deck beams only, then deck girders shall be fitted in line with deckhouse sides. The girders shall extend three frame spaces forward and aft beyond the deckhouse ends. The depth of the girders shall not be less than that of the deck beams plus 100 mm. The girder depth at its ends may be equal to the depth of the deck beams.

10.2.1.7 Deck beams under fore and aft ends of deckhouses shall not be scalloped in way of deckhouse corners.

10.2.2 Additional Requirements

10.2.2.1 Companionways situated on exposed decks shall be efficiently stiffened in accordance with the requirements for deckhouses.

10.2.2.2 Adequate strengthening of sides and decks in deckhouses shall be provided in those places where life boats, boat davits, masts, hoisting winches are situated, as well as in other places where excessive local loads are likely to occur.

10.2.2.3 Flexible seating for superstructures and deckhouses is subject to PRS consideration in each particular case.

10.3 Scantlings of Structural Members

10.3.1 Wall Plating

10.3.1.1 The plating thickness of exposed end bulkheads of superstructures and deckhouses, as well as of exposed sides of deckhouses resulting from lateral external pressure shall not be less than that determined by the formula:

$$t = 18k_a s \sqrt{\frac{p}{\sigma}} \quad [\text{mm}] \quad (10.3.1.1)$$

k_a – to be determined as in 13.4.2.1;

p – see 10.4;

σ = 160k [MPa].

10.3.1.2 The final plate thickness of superstructures and deckhouses walls shall not be less than:

– for the lowest tier:

$$t = 5 + 0.01L_0 \quad [\text{mm}] \quad (10.3.1.2-1)$$

but need not be greater than 8 mm;

– for the other tiers:

$$t = 4 + 0.01L_0 \quad [\text{mm}] \quad (10.3.1.2-2)$$

however, not less than 5 mm and need not be greater than 7 mm.

For ships with $L_0 < 65$ [m], the minimum thickness of plating should be as follows:

– for the lowest unprotected front:

$$t = 5 \text{ [mm]} \quad (10.3.1.2-3)$$

– for the other cases:

$$t = 4 \text{ [mm]} \quad (10.3.1.2-4)$$

10.3.1.3 The thickness of deckhouse plates need not exceed that required for the side plating in a superstructure in the same area.

10.3.2 Wall Stiffeners

10.3.2.1 The section modulus of the stiffeners of end bulkheads of superstructures and deckhouses and in deckhouse sides shall not be less than:

$$W = \frac{100 l^2 s p}{\sigma} \text{ [cm}^3\text{]} \quad (10.3.2.1)$$

p – see 10.4;

$\sigma = 160k$ [MPa] – for longitudinal and vertical stiffeners, in general,

$\sigma = 90k$ [MPa] – for longitudinals at strength deck in long deckhouses amidships; the value of σ may be increased linearly to $160k$ at the first tier deck and at the end parts of the ship,

l, s – see 10.1.3.

10.3.2.2 The scantlings of side stiffeners in superstructures need not be greater than those required for 'tween deck frames with the equivalent connection of stiffener ends.

10.3.2.3 Stiffeners of fore end bulkheads shall be connected to deck at both ends with a connection area not less than:

$$A_p = \frac{0.07 l s p}{k} \text{ [cm}^2\text{]} \quad (10.3.2.3)$$

p – see 10.4,

l, s – see 10.1.3.

Stiffeners of side walls and aft end bulkheads in the lowest tier of erections shall have end connections as brackets or shall be welded to the decks.

10.3.3 Casings

10.3.3.1 The plating thickness in the protected casings shall not be less than:

– in way of cargo holds:

$$t = 8.5s \text{ but } t \geq 6 \text{ [mm]} \quad (10.3.3.1-1)$$

– in way of accommodations:

$$t = 6.5s \text{ but } t \geq 5 \text{ [mm]} \quad (10.3.3.1-2)$$

10.3.3.2 The section modulus of stiffeners shall not be less than:

$$W = 3 l^2 s \text{ [cm}^3\text{]} \quad (10.3.3.2)$$

l – length of stiffeners, however $l \geq 2.5$ [m],

s – stiffeners spacing [m].

10.3.3.3 Casings supporting one or more decks shall be adequately strengthened and the scantlings of stiffeners shall comply with the requirements specified in sub-chapter 13.7.3.

10.3.4 Aluminium Alloy Superstructures

10.3.4.1 The strength of the aluminium alloy superstructures and deckhouses shall be equivalent to that required for steel structures. Connections of steel and aluminium alloy structures shall be made in accordance with the requirements specified in sub-chapter 4.4.

10.3.4.2 Engine and boiler room casings, as well as decks with accommodation and service spaces located above the machinery space and holds shall be made of steel.

10.4 Design Loads on Walls

10.4.1 Design sea pressure p acting on the exposed end bulkheads of superstructures and deckhouses, as well as side walls of deckhouses shall be determined in accordance with the requirements specified in Chapter 16.

10.4.2 Design pressure p assumed for calculations of fore end bulkheads of the lowest tier of superstructures and deckhouses shall not be less than that determined by the formula:

$$p = 12.5 + 0.05L_1 \quad [\text{kPa}] \quad (10.4.2-1)$$

Design pressure p assumed for the remaining tiers shall not be less than that determined by the formula:

$$p = 6.25 + 0.025L_1 \quad [\text{kPa}] \quad (10.4.2-2)$$

$L_1 = L_0$, however, not more than 250 m.

10.4.3 The design pressure for the exposed side walls of deckhouses shall not be less than that determined in accordance with formula 10.4.2-2.

10.4.4 The design pressure for the exposed aft end bulkheads of superstructures and deckhouses shall not be less than that determined in accordance with formula 10.4.2-2.

10.5 Bulwarks

10.5.1 General Requirements

10.5.1.1 The requirements concerning location and height of bulwarks are specified in sub-chapters 9.5 and 14.6, *Part III – Hull Equipment*.

10.5.1.2 In ships with the length $L_0 > 90$ m, the design of the bulwark structure shall preclude it from taking part in the general bending of the hull.

10.5.1.3 Where, in some place, the bulwark is welded to the sheer strake, the smooth transition with a radius of at least 100 mm between the bulwark plating and the sheer strake shall be maintained.

10.5.1.4 Sufficient provision shall be made for freeing the decks from water, particularly in areas where bulwarks and superstructures form wells.

10.5.2 Bulwark Thickness

10.5.2.1 If the bulwarks are of Rule height, their thickness shall not be less than:

$$t = 0.065L_0 + 1.75 \quad [\text{mm}] \quad \text{for } L_0 \leq 60 \text{ m} \quad (10.5.2.1-1)$$

$$t = 0.025L_0 + 4.00 \quad [\text{mm}] \quad \text{for } L_0 > 60 \text{ m} \quad (10.5.2.1-2)$$

The thickness of bulwark plate shall not be less than 3 mm and need not be greater than 8 mm and not greater than that required for the side plating in superstructures.

10.5.2.2 Where the height of a bulwark is 1.8 m and more, the thickness of bulwark plates shall comply with the requirements of 10.3 for side plating in superstructures. The thickness of bulwark plates may be determined by linear interpolation when the height of a bulwark is greater than the Rule value and less than 1.8 m.

10.5.2.3 The thickness of the bulwark plates in superstructures in way of $x \leq 0.25L_0$, as well as of superstructures and deckhouses of the second tier and the tiers above may be decreased by 1 mm.

10.5.3 Stiffening and Bulwark Rails

10.5.3.1 The upper edge of the bulwark shall end with a rail made of adequate firm section, the thickness of which is at least 1 mm greater than that of the bulwark plating.

10.5.3.2 The lower edge of the bulwark in way of a gap between the bulwark and the sheer strake shall be strengthened by a longitudinal stiffener or a flange.

10.5.4 Arrangement of Stays

10.5.4.1 The bulwark shall be supported by stays spaced not more than 1.8 m. In the fore part of the ship for $x > 0.43L_0$, spacings between stays shall be decreased to 1.2 m. Where the flare is large and in ships intended for the carriage of timber on deck, spacings between stays are subject to PRS consideration in each particular case.

10.5.4.2 The stays shall be in line with beams, brackets or additional deck stiffeners.

10.5.5 Scantlings and Structure of Stays

10.5.5.1 Where the bulwark height is 1 m, the width of the lower end of a stay, measured along the connection with the deck, shall not be less than:

$$b = (0.65L_0 + 190)\sqrt{s} \quad [\text{mm}] \quad (10.5.5.1)$$

but need not exceed 360 mm.

s – spacing between stays, [m]; in ships carrying deck cargo and in the fore part of the ship, $s = 1.8$ m shall be taken for calculations, irrespective of a real spacing between stays.

Outside the bow region, where bulwark is welded to the sheer strake, b may be reduced by 20%. Where the height of the bulwark exceeds 1 m, the width b shall be increased in proportion to the bulwark height.

10.5.5.2 The thickness of the stays shall be 1 mm greater than that of the bulwark plating.

10.5.5.3 Stays shall have flanges or flat bars welded to free edges. The width of a flat bar shall not be less than 60 mm, but it shall not exceed 90 mm. Flanges (flat bars) and stiffeners strengthening the lower edge of the bulwark shall not be welded to the deck.

10.5.5.4 Dimensions of the lightening holes in stays shall not exceed half the stay width in any cross-section.

10.5.5.5 The thickness of the stays in way of bulwark cut to form a gangway shall exceed the bulwark thickness by 25%. Additional strengthening of bulwark may be required in way of mooring pipes, fairleads and eye plates for cargo gear.

10.5.5.6 Stays shall be welded to rail, bulwark and deck. The stay shall be welded to the deck with double continuous weld. Adequate openings shall be provided for freeing the deck of water.

11 STEM AND STERNFRAME

11.1 General

11.1.1 Application

The requirements specified in the present Chapter apply to the construction, shape and scantlings of stems and sternframes, including fixed nozzle and rudder horn. The construction, scantlings and fixing of the shaft brackets are subject to PRS consideration in each particular case.

11.1.2 General Requirements

11.1.2.1 Steel castings of stems and sternframes shall be of simple shape with adequately long radii of casting.

11.1.2.2 The welded structure (steel casting) of the stem or sternframe shall be strengthened by transverse brackets (cast webs).

11.1.2.3 The thickness of the plates (the thickness of casting edges) in way of connection with the hull structure shall be reduced to the thickness of members to which the stem or sternframe will be welded.

11.2 Stem

11.2.1 Structure

11.2.1.1 Stem steel plates shall be strengthened by transverse brackets fitted not greater than 1 m apart below the summer load waterline and not greater than 1.5 m apart above the summer load waterline. Longitudinal strengthening for the connection with the bottom centre girder in the stem structure shall be provided.

11.2.1.2 Where the distance between brackets, required in paragraph 11.2.1.1, is reduced by 0.5 m, the thickness of stem plates may be reduced by 20% in relation to requirements given below. The plate thickness, however, shall not be less than that of the adjoining shell plating. The brackets shall extend beyond the joints of the stem with the shell plating. They shall be welded to the nearest frames and their thickness shall be equal to that of the shell plating.

11.2.1.3 Where a radius of curvature of the stem exceeds 200 mm at the level of the summer load waterline, a centreline web with face plates shall be fitted from the keel to the level of $0.15T$ above the summer load waterline. The thickness of the web and the face plate shall not be less than that of the transverse brackets.

11.2.1.4 Where a radius of curvature of the bow is large, the stem design is subject to PRS consideration in each particular case.

11.2.2 Scantlings

11.2.2.1 Dimensions of the bar stem cross-section from the keel to the summer load waterline shall not be less than those determined by the formulae:

$$\text{– length: } l = 1.2L_0 + 95 \text{ [mm]} \quad \text{for } L_0 < 120 \text{ m} \quad (11.2.2.1-1)$$

$$l = 0.75L_0 + 150 \text{ [mm]} \quad \text{for } L_0 \geq 120 \text{ m} \quad (11.2.2.1-2)$$

$$\text{– breadth: } b = 0.4L_0 + 15 \text{ [mm]} \quad (11.2.2.1-3)$$

however, not more than 100 mm.

Above the summer load waterline, the cross-section area of the stem may be gradually tapered to 70% of the area obtained from the scantlings given above.

11.2.2.2 Fabricated stems shall be made of steel plates, the thickness of which shall be determined by the formula:

$$t = 0.105L_0 + 4 \quad [\text{mm}] \quad (11.2.2.2)$$

however, not less than 7 mm.

At $T/L_0 \geq 0.065$, the thickness of the welded stem obtained by the above formula shall be multiplied by the factor $(0.35 + 10 T/L_0)$.

Moreover, the adopted thickness of plates is in no case to be less than that of the plate keel in way of attachment to the stem foot. Above the summer load waterline, the plate thickness may be gradually tapered to the thickness of the shell plating at the ship ends.

11.2.2.3 It is recommended that the length of the cross-section of the fabricated stem be not less than twice that of the bar stem required in paragraph 11.2.2.1.

11.2.3 Bow Bulb Structure

11.2.3.1 The bulb structure shall be strengthened by the stiffened horizontal platforms at spacings not exceeding 2 m.

11.2.3.2 Where the length of the bulb, measured from the forward perpendicular, exceeds $0.03L_0$, the non-tight bulkhead shall be fitted in the centre plane. Where the bulb length is less than that given above, a deep frame may be used instead of a bulkhead.

11.2.3.3 Irrespective of compliance with the requirements specified in Chapters 6 and 7 for the thickness of the bottom and side plating, the thickness of the bulb plating shall not be less than that determined by the formula:

$$t = 0.08 L_0 + 6 \quad [\text{mm}] \quad (11.2.3.3)$$

but need not be greater than 25 mm.

11.2.3.4 The form of the fore part of the hull shall provide for free anchorage at a bulb at a heel of 5° to the opposite side. Additional strengthening shall be fitted in way of the possible anchor blows.

11.3 Sternframe

11.3.1 Structure

11.3.1.1 Sternframe shall be effectively attached to the adjacent hull structure. For this purpose, it shall be strengthened by transverse brackets (webs).

11.3.1.2 Greater propeller posts of the cast sternframes may be made of pieces. Adequate strength of connections of each sternframe piece shall be provided. Welded structure of propeller posts, formed by the adequate steel sections and plates welded to them, may be applied.

11.3.1.3 The sole piece shall be extended forward of the propeller post by at least two frame spacings from the forward edge of the propeller boss. The sectional area of the extended sternframe may be gradually reduced to the value necessary for the connection of the sole piece with the plate keel.

The lower edge of the sole piece shall be raised in order to avoid the pressure from keel blocks during the ship docking.

11.3.2 Scantlings

11.3.2.1 Where the scantlings of sternframe are based on the stress analysis, the stress values shall not be greater than:

- normal stress: $\sigma = 80k$ [MPa],
- shear stress: $\tau = 50k$ [MPa],
- equivalent stress: $\sigma_e = 125k$ [MPa].

11.3.2.2 The thickness of the propeller boss shall not be less than that determined in accordance with the following formula:

$$t = 5\sqrt{d_{sr} - 60} \quad [\text{mm}] \quad (11.3.2.2)$$

d_{sr} – Rule diameter of the propeller shaft, [mm], calculated according to 2.5.1, *Part VI – Machinery Installations and Refrigerating Plants*.

11.3.2.3 The dimensions of the welded propeller post shall not be less than those determined by the formulas (see Fig. 11.3.2.3):

$$l = 53\sqrt{L_0} \quad [\text{mm}] \quad (11.3.2.3-1)$$

$$b = 37\sqrt{L_0} \quad [\text{mm}] \quad (11.3.2.3-2)$$

$$t = 2.4\sqrt{\frac{L_0}{k}} \quad [\text{mm}] \quad (11.3.2.3-3)$$

When the assumed cross-section is different from that shown in Fig. 11.3.2.3, the section modulus calculated for the longitudinal neutral axis shall not be less than that determined in accordance with the following formula:

$$W_s = \frac{1.35L_0\sqrt{L_0}}{k} \quad [\text{cm}^3] \quad (11.3.2.3-4)$$

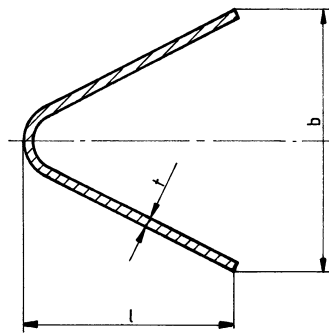

Fig. 11.3.2.3. Welded sternframe propeller post

11.3.2.4 The dimensions of the cast propeller post shall not be less than those determined by the formulae (see Fig. 11.3.2.4):

$$l = 40\sqrt{L_0} \quad [\text{mm}] \quad (11.3.2.4-1)$$

$$b = 30\sqrt{L_0} \quad [\text{mm}] \quad (11.3.2.4-2)$$

$$t_1 = 3\sqrt{\frac{L_0}{k}} \quad [\text{mm}] \quad (11.3.2.4-3)$$

$$t_2 = 3.7 \sqrt{\frac{L_0}{k}} \text{ [mm]} \quad (11.3.2.4-4)$$

When the assumed cross-section is different from that shown in Fig. 11.3.2.4, the section modulus calculated for the longitudinal neutral axis shall not be less than that determined by the formula:

$$W_s = \frac{1.3L_0\sqrt{L_0}}{k} \text{ [cm}^3\text{]} \quad (11.3.2.4-5)$$

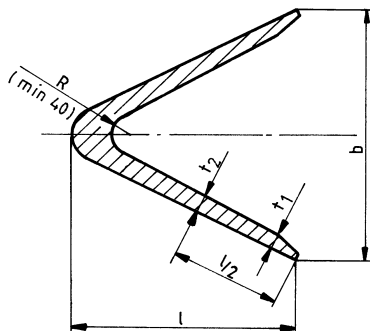

Fig. 11.3.2.4. Cast sternframe propeller post

When determining the section modulus of the propeller post, the adjacent plating of the width up to $53\sqrt{L_0}$ [mm], measured from the aft edge of the propeller post, may be taken into account. This applies also to the welded propeller post.

11.3.2.5 In no cross-section of the sole piece, the section modulus calculated for the vertical neutral axis shall be less than that determined by the formula:

$$W_z = \frac{M_2}{80k} \text{ [cm}^3\text{]} \quad (11.3.2.5)$$

M_2 – bending moment at the section considered – see Fig. 2.2.4.2.1 Part III – Hull Equipment, [Nm],
where $M_{2max} = R_1 l_{50}$;

x – distance from the section y-y in question to the rudder stock axis, [m];

$x_{min} = 0.5l_{50}$; $x_{max} = l_{50}$;

l_{50} – see Fig. 11.3.2.5;

R_1 – the supporting force acting in the pintle bearing [N], normally $R_1 = F/2$ - see Fig. 2.2.4.2.1 Part III – Hull Equipment ;

F – the assumed force acting on the rudder blade, [N], defined according to 2.2.2.1, Part III – Hull Equipment.

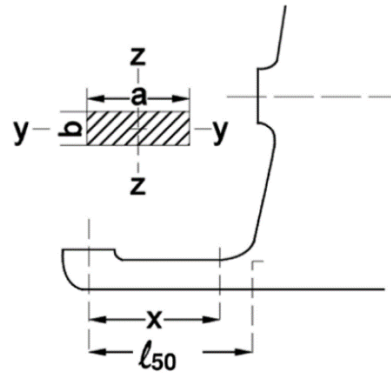

Fig. 11.3.2.5. Stern frame sole piece

11.3.2.6 In no cross-section of the sole piece, the section modulus calculated for the horizontal neutral axis shall be less than that determined in accordance with the following formula:

$$W_y = 0.5W_z \quad [\text{cm}^3] \quad (11.3.2.6)$$

11.3.2.7 No cross-section of the sole piece shall be less than that determined in accordance with the following formula:

$$A_s = \frac{R_1}{4800k} \quad [\text{cm}^2] \quad (11.3.2.7)$$

R_1 – see 11.3.2.5.

11.3.2.8 In no cross-section of the sole piece with the length l_{50} , the equivalent stress shall exceed $115k$ [MPa].

11.3.2.9 The equivalent stress may be determined in accordance with the following formulae:

$$\sigma_e = \sqrt{\sigma^2 + 3\tau^2} \quad [\text{MPa}] \quad (11.3.2.9-1)$$

$$\sigma = \frac{M_2}{W_z(x)} \quad [\text{MPa}] \quad (11.3.2.9-2)$$

$$\tau = \frac{R_1}{100 \cdot A_s} \quad [\text{MPa}] \quad (11.3.2.9-3)$$

σ_e – equivalent stress [MPa];

σ – normal stress [MPa];

τ – shear stress [MPa];

R_1, x, W_z – see 11.3.2.5;

A_s – see 11.3.2.7.

11.3.3 Rudder Horn

11.3.3.1 Rudder horn shall be effectively attached to the adjacent hull structure. When the connection between the rudder horn and the hull structure is designed as a curved transition into the hull plating, special consideration is to be given to the effectiveness of the rudder horn plate in bending and to the stresses in the transverse web plates.

The bending moments and shear forces shall be determined by a direct calculation or in line with the guidelines given in 11.3.4 and 11.3.5 for semi spade rudder with one elastic support and semi spade rudder with 2-conjugate elastic support respectively.

11.3.3.2 The section modulus of the horizontal section of the rudder horn, calculated for the longitudinal neutral axis, shall not be less than that determined in accordance with the following formula:

$$Z_x = \frac{M_b}{67k} \quad [\text{cm}^3] \quad (11.3.3.2)$$

M_b – bending moment at the section considered, [Nm].

11.3.3.3 In no place of the rudder horn, the shear stress shall be greater than: $\tau = 48k$ [MPa]

11.3.3.4 In no section within the height of the rudder horn, the equivalent stress shall be greater than $\sigma_e = 120k$ [MPa].

11.3.3.5 The equivalent stress shall be determined by the formulae:

$$\sigma_e = \sqrt{\sigma_b^2 + 3(\tau_{\square}^2 + \tau_T^2)} \quad [\text{MPa}] \quad (11.3.3.5-1)$$

$$\sigma_b = \frac{M_b}{Z_x} \quad [\text{MPa}] \quad (11.3.3.5-2)$$

$$\tau = \frac{B_1}{A_h} \quad [\text{MPa}] \quad (11.3.3.5-3)$$

$$\tau = \frac{1000M_T}{2A_T t_h} \quad [\text{MPa}] \quad (11.3.3.5-4)$$

A_h – effective shear area of the rudder horn for shear in y -direction [mm^2];

A_T – horizontal cross-section area enclosed by the rudder horn [mm^2];

t_h – thickness of rudder horn plating [mm];

σ_b – normal stress [MPa];

σ_e – equivalent stress [MPa];

τ_T – torsional stress [MPa];

τ – shear stress [MPa];

M_T – torsional moment [Nm];

B_1 – supporting force in the pintle bearing [N].

When calculating the real section modulus of the rudder horn, the total horizontal cross-section area of the rudder horn elements may be taken into account.

11.3.3.6 The thickness of rudder horn side plating shall not be less than:

$$t = 2.4 \sqrt{\frac{L_0}{k}} \quad [\text{mm}] \quad (11.3.3.6-1)$$

L_0 – see 1.2.2;

k – see 2.2.1.

11.3.3.7 The rudder horn plating shall be effectively connected to the aft ship structure, e.g. by connecting the plating to side shell and transverse/longitudinal girders, in order to achieve a proper transmission of forces, see Fig. 11.3.3.7. Brackets or stringers are to be fitted internally in horn, in line with outside shell plate, as shown in Fig. 11.3.3.7.

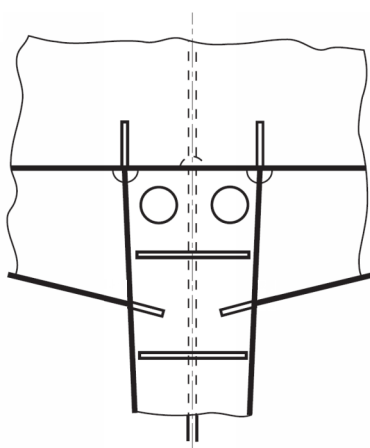

Fig. 11.3.3.7. Connection of rudder horn to aft ship structure

Transverse webs of the rudder horn shall be led into the hull up to the next deck in a sufficient number.

Strengthened plate floors shall be fitted in line with the transverse webs in order to achieve a sufficient connection with the hull.

The centre line bulkhead (wash-bulkhead) in the after peak shall be connected to the rudder horn.

Scallops shall be avoided in way of the connection between transverse webs and shell plating.

The weld at the connection between the rudder horn plating and the side shell shall be full penetration. The welding radius shall be as large as practicable and may be obtained by grinding.

11.3.3.8 Where the connection between the rudder horn and the hull structure is designed as a curved transition into the hull plating (transition zone), then for the horizontal section, situated $0.7r$ above the point where the curved transition starts (see Fig. 11.3.3.6), the section modulus determined in accordance with 11.3.3.2, shall fulfil the following condition:

$$W_p = \frac{\sum_{i=1}^n b_i^3 t_i}{6000 b_m} \geq 0.45 W \quad (11.3.3.8)$$

n – number of horn transverse webs;

b_i – effective breadth of i web (including thicknesses of the both effective platings within the transition zone) [mm];

b_m – the largest b_i [mm];

t_i – thickness of i web [mm];

r – transition zone curvature radius;

W – see 11.3.3.2.

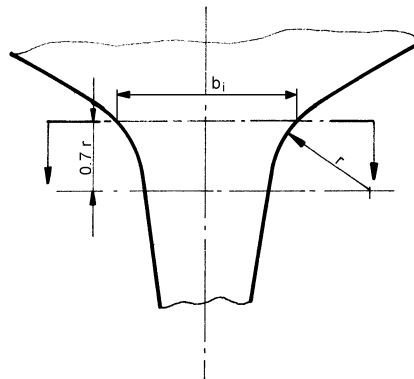

Fig. 11.3.3.8. Transition zone between rudder horn and hull platings

11.3.3.9 The lower end of the rudder horn shall be covered by a horizontal plate, the thickness of which is not less than that of the side plating of the rudder horn.

11.3.3.10 Vertical parts of the rudder horn participating in the strength against transverse shear shall have a total area in horizontal cross-section not less than that determined in accordance with the following formula:

$$A_w = c \frac{0.3F}{k} \cdot 10^{-3} \text{ [cm}^2\text{]} \quad (11.3.3.10)$$

$$c = 1 + \frac{(A + A_0)A_0}{A^2} \text{ - at the upper end of the rudder horn;}$$

$c = 1$ - at the lower end of the rudder horn;

A - area (lateral projection) of the rudder blade, [m²];

A_0 - area (lateral projection) of the rudder horn, [m²];

F - see 11.3.2.5.

11.3.3.11 The thickness of the vertical transverse webs in the transition zone shall not be less than:

$$t_r = \frac{b t_c}{r} \text{ [mm]} \quad (11.3.3.11)$$

b - breadth of the curved plate in the transition zone supported by the web in question, [mm],

t_c - thickness of the curved plate in the transition zone supported by the web in question, [mm],

r - transition zone curvature radius, [mm].

11.3.4 Rudder horn for semi spade rudder with one elastic support

11.3.4.1 If direct calculation have not been performed M_t , M_T and Q may be calculated as below:

Bending moment:

$$M_1 = R_1 \cdot z \text{ [Nm]} \quad (11.3.4.1-1)$$

$$M_{1max} = R_1 \cdot d \text{ [Nm]} \quad (11.3.4.1-2)$$

Shear force:

$$Q = R_1 \text{ [N]} \quad (11.3.4.1-3)$$

Torsional moment:

$$M_T(z) = R_1 \cdot e(z) \text{ [Nm]} \quad (11.3.4.1-4)$$

R_1 – shall be taken from rudder stock calculation, see Fig. 2.2.4.4.1-1, Part III – Hull Equipment, z, d, l_{20}, l_{30} – see Fig. 2.2.4.4.1-1, Part III – Hull Equipment, [m].

An estimate for R_1 is:

$$R_1 = \frac{F \cdot b}{(l_{20} + l_{30})} \quad [\text{N}] \quad (11.3.4.1-5)$$

F – the assumed force acting on the rudder blade [N], see 2.3.3.1, Part III – Hull Equipment.

Other calculations acc. to 11.3.3.

11.3.5 Rudder horn for semi spade rudder with 2-conjugate elastic support

11.3.5.1 Rudder horn bending moment

If direct calculation have not been performed, the bending moment acting on the generic section of the rudder horn shall be obtained from the formulae:

– between the lower and upper supports provided by the rudder horn:

$$M_H = F_{A1}z \quad [\text{Nm}] \quad (11.3.5.1-1)$$

– above the rudder horn upper-support

$$M_H = F_{A1}z + F_{A2}[z - (d - \lambda)] \quad [\text{Nm}] \quad (11.3.5.1-2)$$

where:

F_{A1} – support force at the rudder horn lower-support to be obtained in accordance with Fig. 2.2.4.4.1-2, Part III – Hull Equipment, and taken equal to B_1 , [N];

F_{A2} – support force at the rudder horn upper-support to be obtained in accordance with Fig. 2.2.4.4.1-2, Part III – Hull Equipment, and taken equal to B_2 , [N];

z – distance defined in Fig. 2.2.4.4.1-2, Part III – Hull Equipment, to be taken less than the distance d defined in the same figure, [m];

B_1, B_2 – horizontal support forces at the lower and upper rudder horn bearings, respectively, [kN];

$d - \lambda$ – distance between the rudder-horn lower and upper bearings, [m], see Fig. 2.2.4.4.1-2, Part III – Hull Equipment.

11.3.5.2 Rudder horn shear force

The shear force Q_H acting on the generic section of the rudder horn shall be obtained from the formulae:

– between the lower and upper rudder horn bearings:

$$Q_H = F_{A1} \quad [\text{N}] \quad (11.3.5.2-1)$$

– above the rudder horn upper-bearing:

$$Q_H = F_{A1} + F_{A2} \quad [\text{N}] \quad (11.3.5.2-2)$$

where:

F_{A1}, F_{A2} – support forces, [N].

The torsional moment acting on the generic section of the rudder horn shall be obtained from the formulae:

– between the lower and upper rudder horn bearings:

$$M_T = F_{A1}e_{(z)} \quad [\text{Nm}] \quad (11.3.5.2-3)$$

– above the rudder horn upper-bearing:

$$M_T = F_{A1}e_{(z)} + F_{A2}e_{(z)} \quad [\text{Nm}] \quad (11.3.5.2-4)$$

where:

F_{A1}, F_{A2} – support forces, [N];
 $e_{(z)}$ – torsion lever defined in 11.3.5.4, [m].

11.3.5.3 Rudder horn shear stress calculation

For a generic section of the rudder horn, located between its lower and upper bearings, the following stresses shall be calculated:

τ_s – shear stress to be obtained from the formula:

$$\tau_s = \frac{F_{A1}}{A_H} \quad [\text{MPa}] \quad (11.3.5.3-1)$$

τ_T – torsional stress to be obtained for hollow rudder horn from the formula:

$$\tau_T = \frac{M_T 10^{-3}}{2A_s t_H} \quad [\text{MPa}] \quad (11.3.5.3-2)$$

M_T – torsional moment, [Nm].

For solid rudder horn, τ_T is subject to PRS consideration in each particular case.

For a generic section of the rudder horn, located in the region above its upper bearing, the following stresses shall be calculated:

τ_s – shear stress to be obtained from the formula

$$\tau_s = \frac{F_{A1} + F_{A2}}{A_H} \quad [\text{MPa}] \quad (11.3.5.3-3)$$

τ_T – torsional stress to be obtained for hollow rudder horn from the formula

$$\tau_T = \frac{M_T 10^{-3}}{2A_s t_H} \quad [\text{MPa}] \quad (11.3.5.3-4)$$

For solid rudder horn, τ_T is subject to PRS consideration in each particular case, where:

F_{A1}, F_{A2} – support forces, [N];

A_H – effective shear sectional area of the rudder horn, in [mm²], in y-direction;

M_T – torsional moment, [Nm];

A_s – mean of areas enclosed by outer and inner boundaries of the thin walled section of rudder horn, [m²];

t_H – plate thickness of rudder horn, [mm]. For a given cross section of the rudder horn, the maximum value of τ_T is obtained at the minimum value of t_H .

11.3.5.4 Rudder horn bending stress calculation

For the generic section of the rudder horn within the length d , the bending stress σ_B to be obtained by the formula:

$$\sigma_B = \frac{M_H}{W_x} \quad [\text{MPa}] \quad (11.3.5.4)$$

where:

M_H – bending moment at the section considered, [Nm];

W_x – section modulus, [cm³], about x-axis (see Fig. 2.2.4.4.1-2, Part III – Hull Equipment)

11.4 Clearances between Propeller and Hull

11.4.1 Afterbody shall be so shaped as to ensure a proper flow of water to the propeller and so as to ensure, as far as practicable, uniform wake current field velocity.

11.4.2 For moderately cavitating propellers, the following minimum clearances shall be taken (see Fig. 11.4.2):

– single-screw ships:

$$a \geq 0.2R_s \text{ [m]},$$

$$b \geq (0.7 - 0.04Z_s) \text{ [m]},$$

$$c \geq (0.48 - 0.02Z_s) R_s \text{ [m]},$$

$$e \geq 0.07R_s \text{ [m]},$$

– twin-screw ships:

$$c \geq (0.6 - 0.02Z_s) R_s \text{ [m]},$$

R_s – propeller radius [m],

Z_s – number of propeller blades.

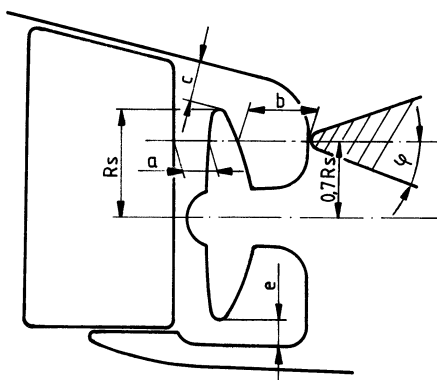

Fig. 11.4.2. Propeller clearance

11.4.3 The apex of the waterlines in front of the propeller shall have the least possible radius r , together with a relatively small angle φ . Plane or approximately plane parts above the propeller tip shall be avoided.

11.5 Fixed Nozzles

11.5.1 Application

The requirements specified in this sub-chapter apply to fixed nozzles of the inner diameter not exceeding 4 m, made of normal strength structural steel. The application of other materials is subject to PRS consideration in each particular case. Nozzles with the inner diameter greater than 4 m are, in each particular case, subject to PRS consideration based on vibration analysis.

11.5.2 Plating

11.5.2.1 The thickness of the nozzle shell in the propeller zone (see Fig. 11.5.2.1) shall be determined in accordance with the following formula:

– for steel with increased corrosion resistance:

$$t = 3.5 + 2.5 n s \sqrt{p} \text{ [mm]} \quad (11.5.2.1-1)$$

however, not less than 10 mm;

– all other cases:

$$t = 7 + 2.5 n s \sqrt{p} \text{ [mm]} \quad (11.5.2.1-2)$$

however, not less than 10 mm;

s – distance between ring webs, [m]; $s \geq 0.35$ m shall be taken for calculations;

n – nozzle curvature factor;

$$n = 1 - 0.14 \frac{s}{l} \sqrt{d} \quad (11.5.2.1-3)$$

l – distance between longitudinal webs of nozzle, measured on the outer plating of the nozzle, [m];

d – propeller diameter, [m];

p – pressure on the nozzle plating;

$$p = 0.25 \frac{N}{A} \left(1 - 0.001 \frac{N}{A} \right) \quad [\text{kPa}] \quad (11.5.2.1-4)$$

N – output delivered to the propeller, [kW].

$$A = \frac{\pi d^2}{4} \quad [\text{m}^2] \quad (11.5.2.1-5)$$

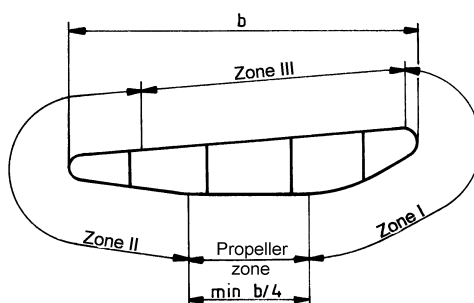

Fig. 11.5.2.1. Longitudinal section through nozzle ring

11.5.2.2 The length of the propeller zone shall not be less than $0.25b$ (b – nozzle length, see Fig. 11.5.2.1).

11.5.2.3 The plating thickness in zones I and II (see Fig. 11.5.2.1) shall be determined in accordance with formula 11.5.2.1-2, assuming $0.5p$ determined in accordance with formula 11.5.2.1-4. The plating thickness within these areas shall not be less than 8 mm.

11.5.2.4 The plating thickness in zone III (see Fig. 11.5.2.1) shall be determined in accordance with formula 11.5.2.1-2, assuming $0.35p$ determined in accordance with formula 11.5.2.1-4.

11.5.2.5 The outer plating in zone II of the nozzle shall cover at least one ring web (see Fig. 11.5.2.1).

11.5.2.6 The thickness of ring webs, as well as longitudinal webs shall not be less than $0.6t$ (t calculated according to 11.5.2.1), however, not less than 8 mm.

11.5.2.7 In ships with ice strengthenings, the nozzle plating thickness shall not be less than that required for the hull plating in the considered part of ship.

11.5.3 Section Modulus of the Longitudinal Section of Nozzle Ring

The section modulus of the longitudinal section of nozzle ring calculated for the neutral axis parallel to the ship centre plane shall not be less than the values determined in accordance with the following formulae:

$$W = 0.7bD^2v^2 \quad [\text{cm}^3] \quad (11.5.3-1)$$

$$W = 6DP \quad [\text{cm}^3] \quad (11.5.3-2)$$

b – nozzle ring length (see Fig. 11.5.2.1), [m];

D – diameter of the nozzle measured to the middle of its thickness, [m];

v – ship speed, [knots]; in ships with ice strengthenings, the speed, taken for calculations, shall not be less than 14, 15, 16 or 17 knots for ice class **L3**, **L2**, **L1** or **L1A**, respectively;

P – water pressure on the nozzle surface,

$$P = 20 \frac{D^2}{T^2} b L_0 \Theta_A \quad [\text{kN}] \quad (11.5.3-3)$$

Θ_A – pitch amplitude, in radians, see 17.3.2;

T – pitch period, [s], determined in accordance with the following formula:

$$T = 1.8 \sqrt{\frac{L_0}{g}} \quad [\text{s}]$$

11.5.4 Welding

11.5.4.1 Ring webs shall be welded to the inner plating of the nozzle with double continuous fillet welding.

11.5.4.2 Ring webs shall be as far as possible welded continuously to the outer plating of the nozzle. All welds of webs to the outer plating may be slot welds if the web spacing does not exceed 350 mm. Otherwise, at least two ring webs shall be welded continuously to the outer shell.

11.5.5 Supporting

11.5.5.1 The nozzle shall be supported by at least two supports. The web plates and plating of the supporting structure shall be in line with web plates in the nozzle.

11.5.5.2 The resultant horizontal force acting on the nozzle side may be determined in accordance with the following formula:

$$P = 0.2bDv \quad [\text{kN}] \quad (11.5.5.2)$$

b, D, v – see 11.5.3.

The vertical water pressure acting on the nozzle external surface due to the ship's pitch may be determined in accordance with formula 11.5.3-3.

11.5.5.3 In no place of the nozzle supporting structure the equivalent stress shall exceed 100 MPa.

11.6 Rudder Trunk

11.6.1 Materials, Welding and Connection to Hull

This requirement applies to trunk configurations which are extended below stern frame and arranged in such a way that the trunk is stressed by forces due to rudder action. The steel used for the rudder trunk shall be of weldable quality, with a carbon content not exceeding 0.23% on ladle analysis and a carbon equivalent C_{EQ} not exceeding 0.41%.

Plating materials for rudder trunks shall not in general be of lower grades than corresponding to class II as defined in 2.2.1.3.

The weld at the connection between the rudder trunk and the shell or the bottom of the skeg shall be with full penetration.

In rudder trunks which are open to the sea, a seal or stuffing box shall be fitted above the deepest load waterline, to prevent water from entering the steering gear compartment and the lubricant from being washed away from the rudder carrier. If the top of the rudder trunk is below the waterline at scantling draught (without trim), two separate watertight seals/stuffing boxes shall be provided.

For rudder trunks extending below shell or skeg, the fillet shoulder radius r , mm (see Fig. 11.6.1-1) shall be as large as practicable and comply with the following formulae:

$$r = 0.1 d_c/k \text{ [mm]} \quad (11.6.1)$$

without being less than:

$$r = 60 \text{ [mm]} \text{ when } \sigma \geq 40/k, \text{ [MPa]}$$

$$r = 30 \text{ [mm]} \text{ when } \sigma < 40/k, \text{ [MPa]}$$

where:

d_c – rudder stock diameter axis, [mm];

σ – bending stress in the rudder trunk, [MPa];

k – material factor, see 2.1.5 in *Part III, Hull Equipment*.

The radius may be obtained by grinding. If disk grinding is carried out, score marks shall be avoided in the direction of the weld. The radius shall be checked with a template for accuracy.

Four profiles at least shall be checked. A report shall be submitted to the Surveyor.

Rudder trunks comprising of materials other than steel are subject to special consideration by PRS.

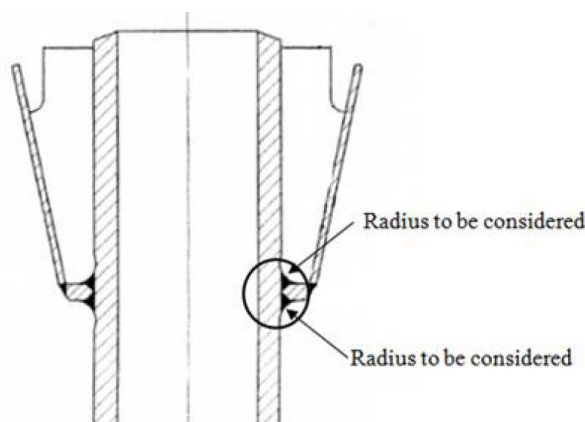

Fig. 11.6.1-1. Fillet shoulder radius

11.6.2 Scantlings

The scantlings of the trunk shall be such that:

- the equivalent stress due to bending and shear does not exceed $0.35R_e$,
- the bending stress on welded rudder trunk shall be in compliance with the following formula:
 $\sigma \leq 80/k$ [MPa],

with:

- σ – bending stress in the rudder trunk, [MPa];
- k – material factor for the rudder trunk determined in accordance with formula 2.1.5 in *Part III, Hull Equipment*;
- R_e – specified minimum yield stress of the material used, [MPa].

For calculation of bending stress, the span to be considered is the distance between the midheight of the lower rudder stock bearing and the point where the trunk is clamped into the shell or the bottom of the skeg.

11.6.3 Reaction Force in Rudder Trunk

Reaction force in rudder trunk at the level of lower bearing shall be determined in accordance with formula 2.2.4.3.2-5, in *Part III, Hull Equipment*.

12 SEATINGS

12.1 General

12.1.1 Application

The requirements specified in the present Chapter apply to the construction of seatings for the main engines, boilers, as well as for deck, processing, cargo handling, auxiliary and other machinery.

12.1.2 General Requirements

12.1.2.1 The main engine seatings and other machinery bearers shall have a strong and rigid structure attached to the strength members of the bottom, sides and decks so as to ensure the transmission of longitudinal and transverse static and dynamic loads from the considered machinery to the hull structure.

12.1.2.2 Access shall be provided to ensure the strength members under the seating to be inspected and measures shall be taken to prevent water from accumulating under the seating. Upon PRS' agreement, a tight structure of the seating may be applied, the inner space of the seating being filled with chemically inert material with good adhesion properties.

12.2 Structure and Scantlings of Structural Members

12.2.1 The seating shall consist, in general, of two longitudinal girders and horizontal bed plates intended for direct fastening the machinery or boiler. The girders and horizontal plates shall be stiffened with brackets or supports where necessary.

12.2.2 When designing the seatings, provision shall be made for avoiding abrupt changes of dimensions. Where this is impracticable, a smooth transition between seating members of different dimensions and between seating members and bottom, sides and deck members shall be provided.

12.2.3 When the single bottom side girder is also considered as the seating web, its thickness shall not be less than that required for the seating web and the centre bottom girder. The height of the bottom floors shall be increased according to the structure of the machinery seatings. The height of the floors between the seating longitudinal girders shall not be less than 0.65 of the height required in the centre plane.

12.2.4 When the bed plates of the main engine and thrust bearing form a part of the inner bottom plating, they shall be supported by two parallel bottom girder webs or by a girder and half-girder webs. The thickness of the webs at the bed plate within 0.2 of their height shall be equal to that of the bed plate or the webs within their full height may be of the thickness required for the seating web.

Longitudinal stiffeners of bed plate shall be fitted between webs. The scantlings of those stiffeners shall be the same as those determined above for the upper parts of girders.

The application of one web only on the bed plate is possible for engines of low power subject to PRS acceptance in each particular case.

In each case the bed plate shall be strengthened within its total length by transverse brackets fitted between the adjacent bolts at equal distances from their centres.

12.2.5 Where longitudinal girders of the seating are fitted to the strength deck, they shall be in line with the underdeck stiffeners.

12.2.6 The scantlings of the seating structure members are a function of the mass of the machinery or boiler or a function of the rated power of the machinery motor. Thickness t of the seating structure members shall not be less than:

- for low-speed engine, boiler or machinery (specified in Table 12.2.6):

$$t = c_1 \sqrt[3]{M} + t_m \quad [\text{mm}] \quad (12.2.6-1)$$

M – mass of engine, boiler or other machinery in operating condition, [t];

c_1 – factor as specified in Table 12.2.6;

t_m – thickness allowance, [mm], depending on the mass M . The following values of t_m shall be taken:

$$t_m = 0 \text{ for } M > 200,$$

$$t_m = 1 \text{ for } 100 < M \leq 200,$$

$$t_m = 2 \text{ for } 50 < M \leq 100,$$

$$t_m = 3 \text{ for } 20 < M \leq 50,$$

$$t_m = 4 \text{ for } M \leq 20.$$

Table 12.2.6
Values of factor c_1

Machinery	Members of seating structure		
	Horizontal plates (bed plates)	Web plates of longitudinal girders ¹⁾	Brackets, including console brackets ²⁾
Main internal combustion engine	4.65	3.00	2.50
Turbine propulsion plants, electric engines and generating sets	4.15	2.70	2.70
Boiler	3.65	2.40	2.40

¹⁾ In the case of the seating with two longitudinal girders at each side of the engine, the thickness of outer girder web plates may be equal to that of the brackets.

²⁾ Console brackets – trapezoid brackets, three edges of which are attached to the seating structure members.

- for medium-speed engine:

$$t = c_2 \sqrt[3]{N} \quad [\text{mm}] \quad (12.2.6-2)$$

$c_2 = 2.3$ for horizontal plate (bed plate),

$c_2 = 1.6$ for web plates of inner girders of seating,

$c_2 = 1.3$ for web plates of outer girders, consoles and brackets;

N – power rating of the engine, [kW].

13 LOCAL STRENGTH AND BUCKLING CONTROL OF THE STRUCTURE

13.1 General

13.1.1 Application

13.1.1.1 The requirements specified in the present Chapter apply to the scantlings of plates, stiffeners, simple primary supporting members, pillars, supporting members, as well as to stiffener and primary supporting members end brackets. The above requirements, except those concerning the minimum scantlings, result from the local design loads on members in question.

13.1.1.2 For plates, stiffeners and simple primary supporting members which take part in the local strength and, in addition, in the longitudinal strength of ship, the requirements concerning the buckling control of these members are given.

13.1.2 Definitions

- A – required cross-sectional area [cm²];
 A_s – required web cross-sectional area [cm²];
 b – breadth of plating supported by a primary supporting member or stiffener in question [m];
 b_m – breadth of the free flange [mm];

$$f = \frac{5.7(M_s + M_w)}{W_1} \quad (13.1.2)$$

- h_s – web height, [mm];
 l – span of a stiffener or a simple girder determined in accordance with sub-chapter 3.2.1, [m];
 $L_1 = L_0$, however, not more than 250 m;
 $L_2 = L_0$, however, not more than 120 m;
 M_s – the maximum value of still water bending moment, obtained as the result of analysis of various load conditions, [kNm]; the assumed value of M_s shall not be less than $0.5M_{so}$ (M_{so} – design minimum still water bending moment, [kNm], determined in accordance with 15.4);
 M_w – Rule wave bending moment, [kNm], determined in accordance with 15.5;
 p – design pressure (see Chapter 16) [kPa];
 s – stiffener spacing measured along the plating [m];
 t – required thickness of the plating [mm];
 t_k – corrosion addition (see sub-chapter 2.5) [mm];
 t_m – flange thickness of stiffener or primary supporting member, [mm]; for bulb section, the mean thickness of the bulb shall be used;
 t_s – web thickness [mm];
 W – required section modulus of a stiffener or a primary supporting member [cm³];
 W_1 – the smallest section modulus of the ship's hull amidships, determined in accordance with 15.7, [cm³]. It should be determined for strength deck – if the member in question is above the horizontal neutral axis of hull cross section, or for the outer bottom – if the considered member is below this axis;
 w_k – section modulus corrosion factor (see paragraph 13.5.2.5);
 z_a – vertical distance from the base plane or the deck line to the point in question below or above the neutral axis, respectively [m];
 z_n – vertical distance from the base plane or the deck line to the neutral axis of the hull girder, whichever is applicable [m];
 σ – allowable normal stress [MPa];
 σ_c – critical compressive buckling stress [MPa];

- σ_E – ideal elastic compressive buckling stress [MPa];
 τ – allowable shear stress [MPa];
 τ_c – critical shear stress [MPa];
 τ_E – ideal elastic buckling shear stress [MPa].

13.1.3 Explanations

Design load point – point at which the design pressure shall be determined in accordance with the requirements specified in Chapter 16.

The location of the load point shall be determined as follows:

- for horizontally stiffened plates: in the midpoint of non-stiffened field;
- for vertically stiffened plates: at the lower edge of the plate for unsupported edges (e.g. when the thickness is changed within the plate area), or in half of the stiffener spacing above the lower edge for supported edges;
- for stiffeners: in span midpoint; where the pressure distribution along the stiffener span is not linear, the design pressure shall be determined in the middle of the span and as the arithmetic mean of pressures at the stiffener ends, whichever is the greater;
- for primary supporting members: in the midpoint of the plating area supported by a primary supporting member.

Effective longitudinal bulkhead – the bulkhead extending from the bottom to the deck attached at the both – fore and aft – ends with ship sides by means of transverse bulkheads. The assumed length of effective bulkhead shall be agreed with PRS.

13.2 Minimum Thickness

13.2.1 General Requirements

The minimum thickness of hull structural members shall not be less than that calculated in accordance with the following formula:

$$t = t_0 + \frac{k_1 L_1}{\sqrt{k}} + t_k \quad [\text{mm}] \quad (13.2.1)$$

- t_0, k_1 – parameters; the values thereof for particular hull members are given below (paragraphs 13.2.2 to 13.2.5);
 k – material factor depending on the material yield stress (see sub-chapter 2.2.1).

When determining the values of t for forepeak and after peak tank primary supporting members, the assumed value L_1 need not exceed 180 m.

13.2.2 Bottom Structure

13.2.2.1 Keel plate: $t_0 = 7.0$; $k_1 = 0.05$.

13.2.2.2 Outer bottom and bilge plating: $t_0 = 5.0$; $k_1 = 0.04$.

13.2.2.3 Inner bottom plating:

$t_0 = 7.0$ – below hatchways in dry cargo ships when ceiling of wood or other approved material is not fitted,

$t_0 = 6.0$ – elsewhere if ceiling is not fitted,

$t_0 = 5.0$ – in general, where ceiling is fitted;

$k_1 = 0.03$.

13.2.2.4 Floors and bottom longitudinal girders, supporting plates and brackets:

$t_0 = 6.0$;
 $k_1 = 0.04$ – for centre girder up to 2 m above the keel plate,
 $k_1 = 0.02$ – for other girders and the remaining part of centre girder.

13.2.2.5 Webs and flanges of longitudinal and transverse frames of the inner and outer bottom, stiffeners of floors, longitudinal girders and supporting plates:

$t_0 = 5.0$;
 $k_1 = 0.03$ – in forepeak and after peak tanks,
 $k_1 = 0.02$ – elsewhere.

13.2.3 Side Structure

13.2.3.1 Side plating:

$t_0 = 5.0$;
 $k_1 = 0.04$ – within $z \leq z_0$, where $z_0 = T + 4.6$ m; within $z > z_0$, the k_1 value may be reduced by 0.01 for each 2.3 m of z increase, but $k_1 \geq 0.01$,
 $k_1 = 0.06$ – for side plating connected to sternframe.

13.2.3.2 Webs and flanges of longitudinal and transverse frames:

$t_0 = 5.0$;
 $k_1 = 0.02$ – in forepeak and after peak tanks,
 $k_1 = 0.01$ – elsewhere.

13.2.3.3 Primary supporting members: flanges, webs, their stiffeners and brackets:

$t_0 = 5.0$;
 $k_1 = 0.03$ – in forepeak and after peak tanks,
 $k_1 = 0.02$ – in ballast and cargo tanks,
 $k_1 = 0.01$ – elsewhere.

13.2.4 Deck Structure

13.2.4.1 Strength deck plating:

$t_0 = 5.5$ – for exposed or cargo deck not sheathed with wood or other approved materials,
 $t_0 = 5.0$ – for exposed or cargo deck sheathed with wood or other approved materials, as well as within accommodation spaces;
 $k_1 = 0.02$ – for single-deck ships,
 $k_1 = 0.01$ – for ships having two continuous decks within $z > 0.7H$,
 $k_1 = 0.01$ – for exposed deck within $x \geq 0.3 L_0$ (minimum value),
 $k_1 = 0.00$ – for ships having more than two continuous decks within $z > 0.7H$.

13.2.4.2 The plating of decks situated above or below the strength deck:

t_0 – as given above for the strength deck;
 $k_1 = 0.01$ – for the deck situated within $z > 0.7H$ in ships with two continuous decks satisfying the condition $z > 0.7H$,
 $k_1 = 0.01$ – for the deck of the first tier of superstructure or deckhouse in single-deck ship if the length of the superstructure or deckhouse situated amidships ($-0.2L_0 \leq x \leq 0.2L_0$) exceeds $0.2L_0$,
 $k_1 = 0$ – for other decks.

13.2.4.3 Webs and flanges of deck longitudinals and beams:

t_0, k_1 – as given above for side frames.

13.2.4.4 Flanges, webs, web stiffeners and deck primary supporting member brackets:

t_0, k_1 – as given above for side primary supporting members.

13.2.5 Bulkhead Structure

13.2.5.1 Bulkhead plating:

$t_0 = 7.0$ – for forepeak and after peak tanks,

$t_0 = 5.0$ – elsewhere;

$k_1 = 0.02$ – in way of cargo (crude oil) tanks, ballast tanks situated in cargo portion of the ship and in forepeak and after peak tanks,

$k_1 = 0.01$ – elsewhere.

13.2.5.2 Webs and flanges of longitudinal, vertical and transverse stiffeners of cargo tank bulkheads, watertight bulkheads in bulk carriers, wash bulkheads:

$t_0 = 5.0$; k_1 – as given above for bulkhead plating.

13.2.5.3 Webs, flanges, stiffeners and brackets of bulkhead primary supporting members: t_0, k_1 – as given above for side primary supporting members.

13.3 Buckling Control of Structural Elements

13.3.1 General Requirements

13.3.1.1 The requirements of this sub-chapter apply to sea-going ships as specified in 1.1.1 except container carriers with length 90 m and above which are covered by requirements of *Publication 114/P – Longitudinal Strength Standard for Container Ships*.

13.3.1.2 The plating and longitudinal girders and stiffeners of the outer and inner bottom, sides, strength deck and longitudinal bulkheads taking part in the hull girder longitudinal strength and situated amidships shall be checked for buckling strength in uni-axial compression.

13.3.1.3 Within transition zones between midship portion of the hull and the peaks, the buckling strength of structural elements specified in paragraph 13.3.1.1 need not be checked. Such check may be required, however, in the case of structural discontinuity in these zones, uneven loading of the ship along its length, as well as in the case of large flare of sides in the ship's forebody.

13.3.1.4 For ships in which the hulls are subjected to considerable shear forces, the plating of sides and longitudinal bulkheads taking part in the hull girder longitudinal strength shall be checked for shear buckling strength. This applies particularly to ships where uneven loading conditions along the ship's length, for tankers also along the ship's breadth, may occur.

13.3.1.5 Compliance with compression buckling strength and shear buckling strength requirements do not preclude special consideration, by PRS, of buckling strength of plates and longitudinal structural elements which are simultaneously subjected to compression and shear. This applies also to bi-axial compression, as well as bi-axial compression and shear.

13.3.1.6 The required scope of buckling control of structural members not specified in paragraphs 13.3.1.1 ÷ 13.3.1.4 is given in detailed requirements referring to those members.

13.3.2 Buckling Strength Criteria and Design Stress Values

13.3.2.1 For members or their parts subject to check for buckling strength in uni-axial compression, the following condition shall be fulfilled:

$$\sigma_c \geq c\sigma_r \quad (13.3.2.1)$$

σ_c – critical compressive buckling stress determined in accordance with 13.3.2.2, taking into account the final scantlings of the member in question, [MPa];

σ_r – design compressive stress determined in accordance with 13.3.2.7, [MPa];

c – coefficient expressing the margin of critical stress in relation to the expected compressive stress:

$c = 1$ – for plate panels and primary supporting member or stiffener webs,

$c = 1.1$ – for stiffeners.

13.3.2.2 Critical stress in uni-axial compression for a member in question shall be determined in accordance with the following formula:

$$\sigma_c = \sigma_E \text{ [MPa] if } \sigma_E \leq \frac{R_e}{2} \quad (13.3.2.2-1)$$

$$\sigma_c = R_e \left(1 - \frac{R_e}{4\sigma_E} \right) \text{ [MPa] if } \sigma_E > \frac{R_e}{2} \quad (13.3.2.2-2)$$

σ_E – ideal elastic compressive buckling stress, [MPa], determined in accordance with 13.4.3 and 13.5.3.

13.3.2.3 For plate panels subject to check for shear buckling strength, the following condition shall be fulfilled:

$$\tau_c \geq \tau_r \quad (13.3.2.3)$$

τ_c – critical shear stress of plate panel determined in accordance with 13.3.2.4, [MPa];

τ_r – design compressive shear stress of plate panel determined in accordance with 13.3.2.8, [MPa].

13.3.2.4 Critical shear stress τ_c for plate panel shall be determined from the formula:

$$\tau_c = \tau_E \text{ [MPa] if } \tau_E \leq 0.5\tau_{pl} \quad (13.3.2.4-1)$$

$$\tau_c = \tau_{pl} \left(1 - \frac{\tau_{pl}}{4\tau_E} \right) \text{ [MPa] if } \tau_E > 0.5\tau_{pl} \quad (13.3.2.4-2)$$

$$\tau_{pl} = \frac{R_e}{\sqrt{3}} \text{ [MPa]} \quad (13.3.2.4-3)$$

τ_E – ideal elastic buckling shear stress, [MPa], determined in accordance with 13.4.3.

13.3.2.5 For plate panels subject to complex stresses (uni-axial or bi-axial compressive stresses combined with shear stresses), the following condition shall be fulfilled:

$$\sigma_{ec} \geq \sigma_{er}$$

σ_{ec} – critical equivalent buckling stress determined in accordance with 13.3.2.6, [MPa];

σ_{er} – design equivalent buckling stress determined in accordance with 13.3.2.9, [MPa].

13.3.2.6 Critical equivalent buckling stress for plate panels subject to complex stresses shall be determined in accordance with the following formula:

$$\sigma_{ec} = \sigma_{eE} \quad \text{if } \sigma_{eE} \leq \frac{R_e}{2} \quad (13.3.2.6-1)$$

$$\sigma_{ec} = R_e \left(1 - \frac{R_e}{4\sigma_{eE}} \right) \quad \text{if } \sigma_{eE} > \frac{R_e}{2} \quad (13.3.2.6-2)$$

σ_{eE} – ideal elastic equivalent buckling stress for plate panels subject to complex stresses, [MPa], determined in accordance with 13.4.3.7.

13.3.2.7 The compressive stress σ_r amidships, due to hull girder bending, which is the basis of the requirements for buckling strength of plate panels, primary supporting member and longitudinal primary supporting members subject to uni-axial compression, shall be determined in accordance with the following formula:

$$\sigma_r = \frac{M_s + M_w}{I_n} z \cdot 10^5 \quad [\text{MPa}] \quad (13.3.2.7-1)$$

The value of σ_r taken for buckling strength analysis of structural members shall fulfil the following condition:

$$\sigma_r \geq 30 k \quad [\text{MPa}] \quad (13.3.2.7-2)$$

M_s – design still water bending moment in the considered transverse cross-section, determined in accordance with 15.4 [kNm];

M_w – wave bending moment in the considered transverse cross-section, determined in accordance with 15.5 [kNm];

I_n – moment of inertia of the considered transverse cross-section of the hull, determined in accordance with 15.7 [cm⁴];

z – vertical distance from neutral axis of the cross-section to the considered point, [m];

k – material factor, determined in accordance with 2.2.1.

M_s and M_w shall be assumed as equal to design values of sagging or hogging moment depending on the position of the considered primary supporting member or stiffener above or below the neutral axis of transverse cross-section of the hull.

If, in all loading conditions in still water, the ship is hogged, then the value of design moment ($M_s + M_w$) will be specially considered by PRS.

The compressive stress σ_r being the result of simultaneous hull girder bending in vertical and horizontal planes and torsion are subject to special consideration by PRS on the basis of criteria given in *Publication 24/P – Strength Analysis of Container Ship Hull Structure*.

The check of buckling strength of plating panels and primary supporting member webs subjected to uni-axial compression does not waive the necessity of checking the buckling strength of the elements subject to complex stresses in accordance with 13.3.2.9 and 13.3.2.10.

13.3.2.8 Shear stresses τ_r in the side plating due to hull girder shear, which is the basis of the requirements for shear buckling strength of plate panels, shall be determined in accordance with the following formula:

– for ships without effective longitudinal bulkheads:

$$\tau_r = \frac{0.5|Q_s + Q_w|}{t} \frac{S_n}{I_n} \cdot 10^2 \text{ [MPa]} \quad (13.3.2.8-1)$$

– for ships with two effective longitudinal bulkheads or double skinned sides:

the stress τ_r in side plating:

$$\tau_r = \frac{|(0.5 - k_s)(Q_s + Q_w) + \Delta Q_{sb}|}{t} \frac{S_n}{I_n} \cdot 10^2 \text{ [MPa]} \quad (13.3.2.8-2)$$

the stress τ_r in longitudinal bulkhead plating:

$$\tau_r = \frac{(k_s(Q_s + Q_w) + \Delta Q_{sg})}{t} \frac{S_n}{I_n} \cdot 10^2 \text{ [MPa]} \quad (13.3.2.8-3)$$

$Q_s, Q_w, S_n, t, I_n, k_s, \Delta Q_{sb}, \Delta Q_{sg}$ – see 15.1.2 and 15.3, 15.9, 15.10, 15.11.

Stresses for ships with one effective longitudinal bulkhead are subject to PRS consideration in each particular case.

13.3.2.9 The design values of equivalent stresses in plate panels or in primary supporting member webs shall be calculated in accordance with the following formula:

$$\sigma_e = \sqrt{\sigma_x^2 + \sigma_y^2 - \sigma_x \sigma_y + 3\tau^2} \text{ [MPa]} \quad (13.3.2.9)$$

σ_x, σ_y, τ – stresses in panel, [MPa], as shown in Fig. 13.3.2.9. Compressive stresses σ_x or σ_y shall be taken as positive.

If σ_x or σ_y is tensile stress then 0 values shall be taken in formula 13.3.2.9. Stresses σ_x, σ_y, τ shall be calculated disregarding cut-outs in the plate panel.

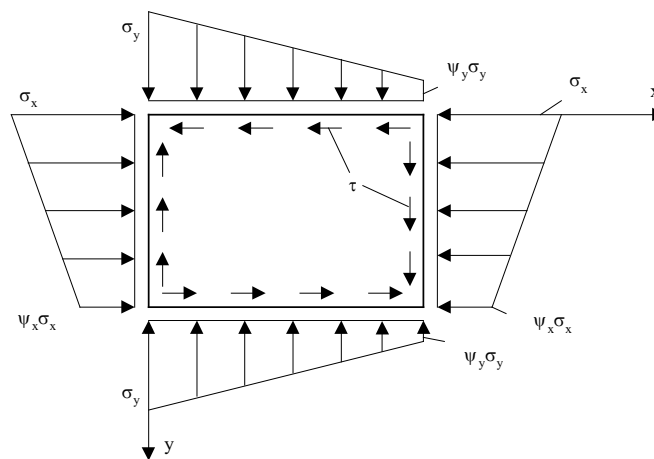

Fig. 13.3.2.9

13.3.2.10 Stress values applied in evaluation of buckling strength of a construction, in cases other than those specified in 13.3.2.7 and 13.3.2.8, shall be calculated within zone strength analysis of the construction in accordance with the provisions of Chapter 14.

In the case of hull primary supporting members and plate panels, in which significant values of bi-axial compressive stresses σ occur or of shear stresses τ acting simultaneously with normal stresses, the buckling strength for combined in-plane loads for design stress values determined in accordance with 13.3.2.9 shall be checked.

For longitudinal structural members, the stresses from hull girder bending or torsion determined in accordance with 13.3.2.7 shall be taken into account.

13.4 Hull Plating

13.4.1 General Requirements

The assumed thickness of the plating shall fulfil the following requirements:

- minimum thickness of structural members specified in 13.2,
- bending strength of plates specified in 13.4.2,
- buckling strength of plate panels specified in 13.3 in accordance with recommendations specified in 13.4.3.

13.4.2 Thickness of Plating

13.4.2.1 The thickness of the plating subjected to lateral pressure shall be determined in accordance with the following formula:

$$t = 18k_a s \sqrt{\frac{p}{\sigma}} + t_k \text{ [mm]} \quad (13.4.2.1-1)$$

$$k_a = \left(1 - 0.27 \frac{s}{l}\right)^2 \quad (13.4.2.1-2)$$

k_a need not be greater than 0.88;

p – design pressure acting on the plate in question, [kPa], to be determined in accordance with the recommendations specified in 16.2÷16.4;

σ – allowable normal bending stress calculated in accordance with 13.4.2.2 or 13.4.2.3, [MPa].

13.4.2.2 Allowable stresses for the plating fitted amidships and taking part in the hull longitudinal strength shall be determined in accordance with Table 13.4.2.2. The assumed value shall not exceed $\sigma_{\max} = 160k$ [MPa].

For plate panels in way of peaks, the value of $\sigma = 160k$ [MPa] shall be taken.

Note: The value of σ varies linearly between the midship and extreme parts of the ship.

Table 13.4.2.2
Allowable stress for plating amidships

Item	Plating in way of:	σ [MPa]
1	outer bottom	
1.1	longitudinally stiffened	120k
1.2	transversely stiffened	175k – 120f
2	inner bottom	
2.1	longitudinally stiffened	140k
2.2	transversely stiffened	200k – 110f, however, not more than 140k
3	sides ¹⁾	
3.1	longitudinally stiffened	140k
3.2	transversely stiffened	120k
4	longitudinal bulkheads ¹⁾	

4.1	longitudinally stiffened	160 <i>k</i>
4.2	transversely stiffened ²⁾	140 <i>k</i>
5	strength deck	
5.1	longitudinally stiffened	120 <i>k</i>
5.2	transversely stiffened	175 <i>k</i> – 120 <i>f</i> , however, not more than 120 <i>k</i>

- 1) Values of σ in way of the neutral axis of the hull cross-section are given. Above and below the neutral axis, the σ shall be linearly reduced to the values required for the deck and bottom plating assuming the same stiffening direction and the material factor as for the plating in question.
- 2) Where the longitudinal bulkhead forms the tank boundary and design pressure $p = p_{10}$ or $p = p_{12}$ was applied, the allowable stress may be increased to $\sigma = 160$ MPa.

13.4.2.3 Allowable stresses σ may be taken equal to 160*k* for the plating of transverse bulkheads, decks below the strength deck and for the side and deck plating in short superstructures and deckhouses.

Allowable stresses for the transverse bulkhead plating for flooded compartment may be taken equal to 220*k* [MPa].

The allowable stress values for longitudinal bulkhead plating in flooded condition are to be taken as:

- .1 at the level of the neutral ship hull axis: 220*k* [MPa],
- .2 for the midship portion, towards the deck, the allowable stress values decrease linearly from the value 220*k*, [MPa], at the neutral axis of ship hull to the value $220k \cdot (\sigma_{deck} / \sigma_{neutral_axis})$, [MPa], where σ_{deck} and $\sigma_{neutral_axis}$ are the allowable stress values given in Table 13.4.2.2 for the longitudinal bulkheads at the deck and neutral axis level,
- .3 for the midship portion, towards the bottom, the allowable stress values decrease linearly from the value 220*k*, [MPa], at the neutral axis of the ship hull to the value $220k \cdot (\sigma_{bottom} / \sigma_{neutral_axis})$, [MPa], where σ_{bottom} and $\sigma_{neutral_axis}$ are the allowable stress values given in Table 13.4.2.2 for the longitudinal bulkheads at the bottom and neutral axis level,
- .4 along the length of the ship hull the stresses should be interpolated as required in p.13.4.2.2, assuming the allowable values in the ship's ends equal to 220*k*, [MPa].

13.4.2.4 The thickness of side and longitudinal bulkhead plating in way of supports of horizontal primary supporting members on the transverse bulkheads shall be adequately increased.

13.4.3 Buckling Strength of Plating and Primary Supporting Member Webs

13.4.3.1 The provisions specified in sub-chapter 13.4.3 apply to determining the ideal elastic buckling stresses for actual dimensions of the plate panels subjected to uni-axial compression, shear, or combined in-plane loads.

13.4.3.2 The plate panels and primary supporting member webs of the outer and inner bottom, sides, strength deck and longitudinal bulkheads taking part in the hull girder longitudinal strength shall comply with the requirements of 13.3 for the buckling strength of uni-axial compressed plates, the ideal elastic buckling stress σ_E being calculated in accordance with 13.4.3.4 and τ_E calculated in accordance with 13.4.3.5, if applicable.

All panels of hull plating, bulkheads, walls and primary supporting member webs, in cases specified in 13.3.2.10, shall fulfil buckling strength criteria for combined in-plane loads, specified in 13.3.2.5, unless PRS allows the application of requirements specified in 13.4.3.3 to certain panels.

13.4.3.3 Elastic buckling of panels may be accepted upon special consideration by PRS. In such cases the evaluation of the hull longitudinal strength shall be based on the reduced effective width of the plate panels.

13.4.3.4 Ideal elastic buckling stress σ_E for compression of plate fields within the adjacent supporting contour shall be determined in accordance with the following formula:

$$\sigma_E = 0.9 m E \left[\frac{t_n}{1000 s} \right]^2 \quad [\text{MPa}] \quad (13.4.3.4-1)$$

For plate fields stiffened longitudinally (parallel to compressive stress):

$$m = \frac{8.4}{k_2 + 1.1} \quad (13.4.3.4-2)$$

For plate fields stiffened transversely (perpendicularly to compressive stress):

$$m = c \left[1 + \left(\frac{s}{l} \right)^2 \right]^2 \frac{2.1}{k_2 + 1.1} \quad (13.4.3.4-3)$$

E – see 1.2.1;

t_n – net thickness of plating panel, [mm], taking into account the standard deduction, determined in accordance with Table 13.4.3.4;

s – length of shorter side of plate field, [m];

l – length of longer side of plate field, [m];

$c = 1.30$ – where the plating is stiffened with bottom floors or deep girders,

$c = 1.21$ – where stiffeners are angles or T-sections,

$c = 1.10$ – where stiffeners are bulb flats,

$c = 1.05$ – where stiffeners are flat bars;

k_2 – is the ratio of the smallest and the largest compressive stress σ (see Fig. 13.4.3.4).

The assumed value of k_2 shall meet the condition $0 \leq k_2 \leq 1$.

For plates with cut-outs, σ_E shall be corrected in accordance with 13.4.3.8, 13.4.3.10 and 13.4.3.11.

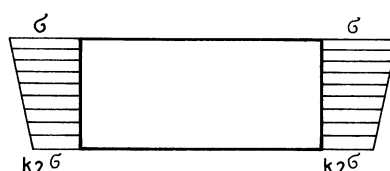

Fig. 13.4.3.4. Definition of factor k_2

Table 13.4.3.4

Item	Structure	Standard deduction [mm]	Limit values min – max [mm]
1	– Compartments carrying dry bulk cargoes. – Vertical surfaces and surfaces sloped at an angle greater than 25° to the horizontal line at one side exposed to ballast and/or liquid cargo.	0.05t	0.5 – 1
2	– Horizontal surfaces and surfaces sloped at an angle less than 25° to the horizontal line at one side exposed to ballast and/or liquid cargo. – Vertical surfaces and surfaces sloped at an angle greater than 25° to the horizontal line at two sides exposed to ballast and/or liquid cargo.	0.10t	2 – 3
3	– Horizontal surfaces and surfaces sloped at an angle less than 25° to the horizontal line at two sides exposed to ballast and/or liquid cargo.	0.15t	2 – 4

13.4.3.5 The ideal elastic buckling shear stress τ_E of plate fields within the adjacent supporting contour shall be determined in accordance with the following formula:

$$\tau_E = 0.9k_t E \left(\frac{t_n}{1000s} \right)^2 \quad [\text{MPa}] \quad (13.4.3.5-1)$$

$$k_t = 5.34 + 4 \left(\frac{s}{l} \right)^2 \quad (13.4.3.5-2)$$

For E, t_n, s, l – see 13.4.3.4.

For plates with cut-outs, τ_E shall be corrected in accordance with 13.4.3.9, 13.4.3.10 and 13.4.3.11.

13.4.3.6 For plate field subjected to combined in-plane load (Fig. 13.3.2.9), the values of ideal elastic buckling stresses $\sigma'_{xE}, \sigma'_{yE}, \tau'_E$ shall be determined in accordance with the following formula:

$$\frac{\sigma'_{xE}}{\sigma_{xE}} + \frac{\sigma'_{yE}}{\sigma_{yE}} + \left(\frac{\tau'_E}{\tau_E} \right)^2 = 1 \quad (13.4.3.6)$$

where:

σ'_{xE} – value of ideal elastic buckling stress at compression along axis x , in case of combined in-plane load, as shown in Fig. 13.3.2.9;

σ_{xE} – value of ideal elastic buckling stress at uni-axial compression along axis x (Fig. 13.4.3.4), calculated as σ_E in accordance with 13.4.3.4;

$\sigma'_{yE}, \sigma_{yE}$ – like $\sigma'_{xE}, \sigma_{xE}$, but at compression along axis y ;

τ'_E – ideal elastic shear stress value for combined in-plane load, as shown in Fig. 13.3.2.9;

τ_E – ideal elastic shear stress value for pure shearing, calculated in accordance with 13.4.3.5.

When calculating the values of $\sigma'_{xE}, \sigma'_{yE}$ and τ'_E in accordance with formula 13.4.3.6, they shall be assumed to be directly proportional to the values of stresses σ_x, σ_y, τ determined in accordance with 13.3.2.9 and 13.3.2.10. Compressive stresses shall be taken as positive. Where σ_x or σ_y are tensile, $\sigma'_{xE} / \sigma_{xE}$ or $\sigma'_{yE} / \sigma_{yE}$ shall be taken equal to 0 in formula 13.4.3.6.

13.4.3.7 The values of equivalent ideal elastic stress for plate subjected to combined in-plane load shall be calculated in accordance with the following formula:

$$\sigma_{eE} = \sqrt{(\sigma'_{xE})^2 + (\sigma'_{yE})^2 - \sigma'_{xE}\sigma'_{yE} + 3(\tau'_E)^2} \quad (13.4.3.7)$$

$\sigma'_{xE}, \sigma'_{yE}, \tau'_E$ – ideal elastic stresses calculated in accordance with 13.4.3.6; they shall be non-negative numbers.

13.4.3.8 Where a circular or oval opening has been cut out in the centre of the panel field, the values of σ_E calculated in accordance with 13.4.3.4 shall be corrected through multiplying by non-dimensional factor r_k of values determined according to Table 13.4.3.8.

Table 13.4.3.8
Correction factors for panels with openings subjected to uni-axial compression

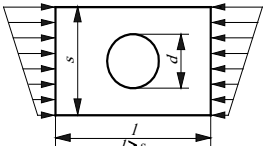
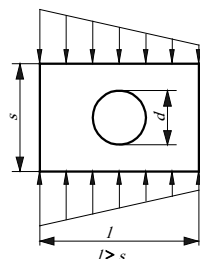
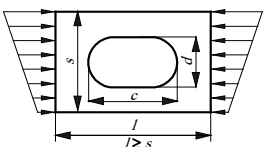
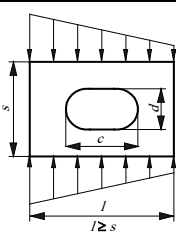
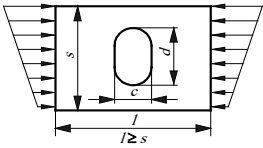
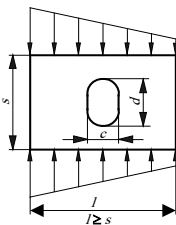
Item	Type of opening and direction of compression	Value of r_k and scope of application
1		$r_k = 1.17 - 1.41 \frac{d}{s} + 1.17 \left(\frac{d}{s} \right)^2$ for: $0.3 \leq \frac{d}{s} \leq 0.7$
2		$r_k = 0.85$ for: $0.3 \leq \frac{d}{s} \leq 0.7$
3		$r_k = 0.66 \text{ for } 1 \leq \frac{l}{s} \leq 2; r_k = 0.76 \text{ for } \frac{l}{s} > 2$ Values of r_k valid for: $0.3 \leq \frac{d}{s} \leq 0.7$ and $1.25 \leq \frac{c}{d} \leq 2$
4		$r_k = 0.82 \text{ for } 1 < \frac{l}{s} \leq 2; r_k = 0.66 \text{ for } \frac{l}{s} > 2$ Values of r_k valid for: $0.3 \leq \frac{d}{s} \leq 0.75$ and $1.25 \leq \frac{c}{d} \leq 2$
5		$r_k = 0.78 \text{ for } 1 \leq \frac{l}{s} \leq 2; r_k = 0.85 \text{ for } \frac{l}{s} > 2$ Values of r_k valid for: $0.3 \leq \frac{d}{s} \leq 0.75$ and $1.25 \leq \frac{d}{c} \leq 2$
6		$r_k = 0.74 + 0.03 \frac{l}{s}$ for: $0.3 \leq \frac{d}{s} \leq 0.75$ and $1.25 \leq \frac{d}{c} \leq 2$

13.4.3.9 Where a circular or oval opening has been cut out in the centre of the panel field, the values of τ_E calculated in accordance with 13.4.3.5 shall be corrected through multiplying by non-dimensional factor r_k of values determined in accordance with Table 13.4.3.9.

Table 13.4.3.9
Correction factors for panels with openings subjected to shear stresses only

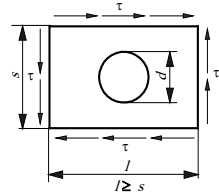
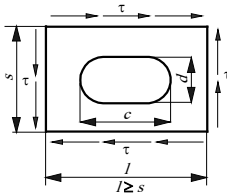
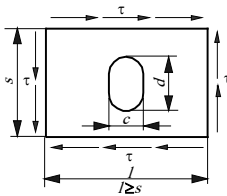
Item	Type of opening	Value of r_k and scope of application
1		$r_k = 1.17 - 2.32 \frac{d}{s} + 1.31 \left(\frac{d}{s} \right)^2$ for: $0.3 \leq \frac{d}{s} \leq 0.7$
2		$r_k = 1.17 - 2.32 \frac{d}{s} + 1.31 \left(\frac{d}{s} \right)^2 + 0.16 \left(1.75 - \frac{c}{d} \right) + \Delta r$ for: $1.25 \leq \frac{c}{d} \leq 2$; $0.3 \leq \frac{d}{s} \leq 0.7$ where: $\Delta r = 0.08 \left(\frac{l}{s} - 2.5 \right)$, for $1.5 < \frac{l}{s} < 2.5$; $\Delta r = 0$ – for other values $\frac{l}{s}$
3		$r_k = 1.17 - 2.32 \frac{d}{s} + 1.31 \left(\frac{d}{s} \right)^2 + 0.22 \left(1 - \frac{c}{d} \right) + \Delta r$ for: $0.5 \leq \frac{c}{d} \leq 0.75$; $0.3 \leq \frac{d}{s} \leq 0.7$ where: $\Delta r = 0.3 \frac{l}{s} - 0.06 \left(\frac{l}{s} \right)^2 - 0.25$, for $\frac{l}{s} \leq 2.5$; $\Delta r = 0.125$, for $\frac{l}{s} > 2.5$

13.4.3.10 For the plate panels with circular or oval opening cut out in the centre of the panel field and strengthened with a flat bar welded around to the edge of the opening symmetrically to the panel plane, the ideal elastic stresses calculated in accordance with 13.4.3.8 or 13.4.3.9 may be corrected in the following way:

a) where the thickness of the flat bar is not less than the panel plate thickness and the flat bar height is not less than four times the thickness of panel plate, then for the plate panel subject to uni-axial compression:

$$r_k = 1 \quad (13.4.3.10-1)$$

b) for the plate panel subject to shear only, strengthened in way given in a), value r_k in accordance with Table 13.4.3.9 shall be additionally multiplied by the factor:

$$r_u = 0.3 + 2.0 \frac{d}{s} + 0.2 \frac{c}{d} + 0.6 \frac{s}{l} \quad (13.4.3.10-2)$$

- l, s, c, d – dimensions as shown in figures in Table 13.4.3.9;
- $c = d$ – for a circular cut-out;

c) where, in pure shear, the opening edge has been strengthened with a flat bar of thickness not less than two times the panel plate thickness and the height not less than four times panel plate thickness, then:

$$r_k = 1 \quad (13.4.3.10-3)$$

13.4.3.11 Where the panel with a circular or oval opening in the centre has been strengthened, as shown in Fig. 13.4.3.11, with flat bars of thickness not less than the panel plate thickness and the height not less than four times the panel plate thickness, then for panels subjected to pure shear, the values of τ_E calculated in accordance with 13.4.3.5 may be corrected, in relation to the requirements of 13.4.3.9, by multiplying the value of r_k (calculated in accordance with Table 13.4.3.9) by factor r_u determined in the following way:

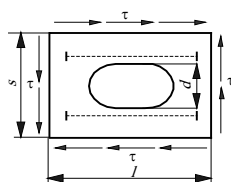

Fig. 13.4.3.11

$$r_u = \left(2 - \frac{d}{s}\right) \left(0.6 + 0.1 \frac{h}{t}\right) \quad (13.4.3.11)$$

where:

d, s – dimensions as shown in Fig. 13.4.3.11;

h, t – height and thickness of flat bars [mm].

For the plate panels subject to uni-axial compression, strengthened as specified above, stresses σ_E for each of three parts of the panel, formed due to the application of flat bars (Fig. 13.4.3.11) may be calculated in accordance with 13.4.3.4, i.e. assuming that flat bars are the stiff support for the panel plate and ignoring the opening. The above-mentioned flat bars shall then meet the requirements specified in 13.3.2.1 in association with the requirements specified in 13.5.3.2 and 13.5.3.3.

13.5 Stiffeners

13.5.1 General Requirements

13.5.1.1 The scantlings of various stiffeners cross-sections shall comply with the following requirements concerning:

- the minimum thickness of structural members specified in 13.2,
- the bending strength of a stiffener due to lateral load specified in 13.5.2,
- stiffener buckling strength, specified in 13.3, taking into account the requirements specified in 13.5.3, where applicable.

13.5.1.2 In cases, specified in 14.7.1, checking the strength of stiffeners with the use of FEM calculations in accordance with the requirements of 14.7.3, may be required.

13.5.1.3 The scantlings of stiffeners transferring compressive axial loads shall be determined in accordance with 13.7.3.

13.5.2 Section Modulus

13.5.2.1 The net section modulus, i.e. after deduction of corrosion additions in accordance with 2.5 (see also 13.5.2.5) for:

- longitudinal and transverse stiffeners of the outer and inner bottom and of sides, as well as stiffeners of tight floors and longitudinal primary supporting members;
- longitudinal and transverse stiffeners of decks and platforms,
- longitudinal and transverse, horizontal and vertical stiffeners of bulkheads and partitions subjected to lateral load,

shall be not less than:

$$W = \frac{1000 I^2 s p}{m \sigma} \quad [\text{cm}^3] \quad (13.5.2.1)$$

however, not less than 15 cm³.

m – the bending moment factor in accordance with 13.5.2.2 (see also 13.5.2.4), as well as Table 5.2.3.3.

The allowable stresses σ shall be determined as follows (see also 13.5.2.3):

- for longitudinal stiffeners in the midship part of ship: from Table 13.5.2.1 and the assumed values shall not exceed $\sigma_{\text{max}} = 160k$ [MPa].

Table 13.5.2.1
Allowable stress for longitudinal stiffeners in the midship part of ship

Item	Longitudinal stiffener in way of:	σ [MPa]
1	Outer bottom:	
1.1	– in double bottom	$225k - 130f - \sigma_{dp}$ $225k - 130f$
1.2	– in single bottom	
2	Inner bottom – in way of cargo hold	$225k - 100f - \sigma_{dp}$
3	Tight longitudinal girders	$225k - 110f$
4	Sides	$225k - 130f(z_n - z_a) / z_n$ max. 130k in single-deck ships
5	Longitudinal bulkheads	$225k - 130f(z_n - z_a) / z_n$
6	Deck:	
6.1	– strength deck, long superstructure and effective deckhouse above the strength deck	$225k - 130f$
6.2	– continuous decks below the strength deck	$225k - 130f(z_n - z_a) / z_n$

- for longitudinal stiffeners in ship ends: $\sigma = 160k$ [MPa]; the value of σ may be varied linearly between the midship part and the ship's ends;
- for transverse stiffeners (vertical and horizontal), including collision bulkhead stiffeners: $\sigma = 160k$ [MPa];
- for stiffeners of other watertight bulkheads : $\sigma = 220k$ [MPa].

The allowable stress values for stiffeners of longitudinal bulkheads in flooded condition are to be taken as:

- at the level of the neutral ship hull axis: 220k [MPa],

- for the midship portion, towards the deck, the allowable stress values decrease linearly from the value $220k$, [MPa], at the neutral axis of ship hull to the value $220k \cdot (\sigma_{deck} / \sigma_{neutral_axis})$, [MPa], where σ_{deck} and $\sigma_{neutral_axis}$ are the allowable stress values given in Table 13.5.2.1 for the longitudinal bulkheads at the deck and neutral axis level,
- for the midship portion, towards the bottom, the allowable stress values decrease linearly from the value $220k$, [MPa], at the neutral axis of ship hull to the value $220k \cdot (\sigma_{bottom} / \sigma_{neutral_axis})$, [MPa], where σ_{bottom} and $\sigma_{neutral_axis}$ are the allowable stress values given in Table 13.5.2.1 for the longitudinal bulkheads at the bottom and neutral axis level,
- along the length of the ship hull the stresses should be interpolated as required in p.13.5.2.1, assuming the allowable values in the ship's ends equal to $220k$, [MPa].

σ_{dp} – stresses in stiffeners face plate due to double bottom bending in way of the considered cargo hold, [MPa], determined in accordance with the requirements specified in Chapter 14.

The applied values of σ_{dp} shall not be less than:

$\sigma_{dp} = 15k$ [MPa] – for dry cargo holds,

$\sigma_{dp} = 35k$ [MPa] – for cargo holds intended for liquid cargo or ballast,

$\sigma_{dp} = 50k$ [MPa] – for bulk carrier holds,

$\sigma_{dp} = 60k$ [MPa] – for holds of bulk carriers with mark **HC/E** and **BC-A**.

13.5.2.2 The following values of the bending moment factor m shall be substituted into formula 13.5.2.1:

$m = 12$ for continuous longitudinal stiffeners,

$m = 10$ for discontinuous longitudinal and transverse stiffeners,

$m = 7.5$ for free supported vertical stiffeners,

$m = 10$ for vertical stiffeners which may be considered fixed at both ends.

For watertight bulkhead structures exposed to sea pressure in flooded conditions:

$m = 16$ for stiffener fixed at both ends,

$m = 12$ for stiffener fixed at one (lower) end and simply supported at the other,

$m = 8$ for stiffener simply supported at both ends.

Note: The above values of m for watertight bulkheads have been based on the assumption that plastic hinges occur at fixed supports and shall not be compared with the bending moment factor m corresponding to elastic bending.

13.5.2.3 The stiffener and plating shall generally be of steel with the same yield stress. If the stiffener is of a greater value of yield stress than that of the plating, σ corresponding to the plate material shall be applied. If the calculated stress in the plating is less than the applicable limit, the value of σ for the stiffener may be multiplied by a factor not greater than k_u/k_p (k_u – material factor for stiffener; k_p – material factor for plating).

13.5.2.4 In special cases stiffeners may be snipped at the ends if the thickness of plating supported by the stiffener is not less than:

$$t = 1.25 \sqrt{\frac{(1 - 0.5s) s p}{k}} + t_k \quad [\text{mm}] \quad (13.5.2.4)$$

In this case the section modulus shall be calculated from formula 13.5.2.1, taking $m = 8$, $\sigma = 145k$ [MPa].

13.5.2.5 Design section moduli of stiffeners (within region A or B area in accordance with sub-chapter 2.5) shall be increased in relation to values W , calculated from formula 13.5.2.1, due to corrosion additions.

For stiffeners welded of web and face plate or made of flat bars, adequate value of t_k (see 2.5) shall be added to the web and face plate thicknesses to ensure the required value of net section modulus.

For stiffeners made of rolled sections, the design section modulus may be calculated as the product of W calculated from formula 13.5.2.1 and factor w_k , determined from the following formulae:

– for angles:

$$w_k = 1 + 0.1 t_k \quad (13.5.2.5-1)$$

– in other cases:

$$w_k = 1 + 0.06 t_k \quad (13.5.2.5-2)$$

t_k – corrosion allowance addition, see 2.5.

13.5.3 Buckling Strength of Stiffeners

13.5.3.1 The scantlings of cross-section of:

- longitudinal stiffeners of bottom, sides, strength deck and longitudinal bulkheads taking part in the ship longitudinal strength,
- stiffeners and primary supporting members of bulkheads and sides,
- pillars,
- cross-ties,
- rows of panting beams fitted at the side stringers level in forepeak and after peak,
- primary supporting member webs stiffeners

shall fulfil the requirements specified in 13.3 for buckling strength, applying the ideal elastic buckling stress σ_E determined below.

The following buckling modes of a stiffener shall be considered:

- lateral buckling of the whole stiffener,
- torsional buckling of the whole stiffener,
- local web buckling,
- flange buckling.

13.5.3.2 For checking the lateral buckling strength of longitudinal stiffeners subjected to compression loads due to hull girder bending, bulkhead supporting stiffeners, pillars, cross-ties, rows of panting beams in the forepeak and longitudinal stiffeners of primary supporting member webs, the ideal elastic buckling stress σ_E may be determined in accordance with the following formula:

$$\sigma_E = 0.001 E \frac{I_\alpha}{A I^2} \quad [\text{MPa}] \quad (13.5.3.2)$$

I_α – moment of inertia, without corrosion allowance, about the axis perpendicular to the expected direction of buckling, i.e. perpendicular to the plating, [cm⁴];

A – cross-sectional area of stiffener, [cm²].

When calculating I_α and A , the effective width of plating equal to the stiffener spacing and the thickness equal to t_n may be included – see 13.4.3.4.

The σ_E value, calculated in accordance with formula 13.5.3.2, corresponds to simply supported ends of the stiffener and axial compression.

If, in a particular case, it is verified that one end can be regarded as fixed, the value σ_E may be multiplied by 2. If it is verified that both ends can be regarded as fixed, the value of σ_E may be multiplied by 4.

The ends of stiffener may be considered fixed if:

- they are connected to the primary supporting members having considerable bending stiffness in relation to the stiffener, in two perpendicular directions,
- they have end brackets on both ends.

13.5.3.3 At checking the torsional buckling strength of a stiffener, the value of σ_E may be determined in accordance with the following formula:

$$\sigma_E = \frac{\pi^2 EI_w}{10^4 I_0 l^2} \left(m^2 + \frac{K}{m^2} \right) + 0.385 E \frac{I_t}{I_0} \quad [\text{MPa}] \quad (13.5.3.3-1)$$

$$K = \frac{cl^4}{\pi^4 EI_w} \cdot 10^6 \quad (13.5.3.3-2)$$

m – number of buckling made half-waves, it may be determined from the following formula:

$$(m - 1)^2 m^2 < K \leq (m + 1)^2 m^2$$

where:

- $m = 1$ for $0 < K \leq 4$;
- $m = 2$ for $4 < K \leq 36$;
- $m = 3$ for $36 < K \leq 144$;
- $m = 4$ for $144 < K \leq 400$;

I_w – sectorial moment of inertia of the stiffener cross-section about connection of stiffener to plating, [cm⁶]:

- for flat bars:

$$I_w = \frac{h_s^3 t_s^3}{36} \cdot 10^{-6} \quad (13.5.3.3-3)$$

- for T-sections:

$$I_w = \frac{t_m b_m^3 h_s^2}{12} \cdot 10^{-6} \quad (13.5.3.3-4)$$

- for angles and bulb floats:

$$I_w = \frac{b_m^3 h_s^2}{12 (b_m + h_s)^2} \left[t_m (b_m^2 + 2 b_m h_s + 4 h_s^2) + 3 t_s b_m h_s \right] \cdot 10^{-6} \quad (13.5.3.3-5)$$

h_s – web height, [mm];

t_s – web thickness, [mm], minus standard deduction in accordance with 13.4.3.4, i.e. assuming $t_s = t_n$;

b_m – flange width, [mm];

t_m – flange thickness, [mm], minus standard deduction in accordance with 13.4.3.4. For bulb sections, the mean thickness of bulb shall be taken;

l – span of stiffener, [m];

I_0 – polar moment of inertia of stiffener cross-section about connection of stiffener to plating, [cm⁴]:

- for flat bars:

$$I_0 = \frac{h_s^3 t_s}{3} \cdot 10^{-4} \quad (13.5.3.3-6)$$

- for stiffeners with flange:

$$I_0 = \left[\frac{h_s^3 t_s}{3} + h_s^2 b_m t_m \right] \cdot 10^{-4} \quad (13.5.3.3-7)$$

I_t – St. Venant's moment of inertia of stiffener cross-section (without effective plate flange), [cm⁴]:

- for flat bars:

$$I_t = \frac{h_s^3 t_s}{3} \cdot 10^{-4} \quad (13.5.3.3-8)$$

- for stiffeners with flange:

$$I_t = \frac{1}{3} \left[h_s t_s^3 + b_m t_m^3 \left(1 - 0.63 \frac{t_m}{b_m} \right) \right] \cdot 10^{-4} \quad (13.5.3.3-9)$$

c – spring stiffness exerted by supporting plate panel:

$$c = \frac{k_p E t_p^3}{3s \left(1 + \frac{1.33 k_p h t_p^3}{1000 s t_s^3} \right)} \cdot 10^{-3} \quad (13.5.3.3-10)$$

$k_p = 1 - r$, however, not less than $k_p = 0$ (13.5.3.3-11)

$$r = \frac{\sigma_r}{\sigma_{Ep}} \quad (13.5.3.3-12)$$

σ_r – design compressive stress, [MPa]; for longitudinal deck beams, bottom and side frames, as well as stiffeners of longitudinal bulkheads – see 13.3.2.7;

σ_{Ep} – ideal elastic buckling stress of supporting plate in accordance with 13.4.3.4;

t_p – plating thickness, [mm], minus standard deduction in accordance with 13.4.3.4.

For stiffeners with flanges, the assumed value of k_p factor need not be taken less than 0.1.

13.5.3.4 For checking the local buckling strength of a web, the value σ_E may be determined in accordance with the following formula:

$$\sigma_E = 3.8 E \left(\frac{t_s}{h_s} \right)^2 \text{ [MPa]} \quad (13.5.3.4)$$

h_s – see 13.1.2;

t_s – web thickness, [mm], minus standard deduction in accordance with paragraph 13.4.3.4.

13.5.3.5 Buckling strength of flange of longitudinal stiffener made of angle or T-section may be considered sufficient if the following requirement is fulfilled:

$$t_m \geq \frac{1}{15} b_m \sqrt{k} \quad (13.5.3.5)$$

b_m – flange width for angle bar, half the flange width for T-sections, [mm];

t_m – design flange thickness;

k – material factor.

13.5.3.6 For stiffeners supporting plate panels subject to compression perpendicular to the stiffener direction (e.g. transverse deck beams of strength deck, vertical side frames and stiffeners of longitudinal bulkheads), the moment of inertia of stiffener cross-section, including effective plate flange, shall not be less than:

$$I = \frac{0.09 \sigma_r \sigma_E l^4 s}{t} \quad [\text{cm}^4] \quad (13.5.3.6-1)$$

t – plate thickness, [mm];

σ_r – compressive stress, [MPa], acting in plate panels perpendicular to the stiffener direction;

$\sigma_E = 1.18 \sigma_r$ [MPa] – when $\sigma_E \leq 0.5 R_e$, (13.5.3.6-2)

$\sigma_E = \frac{R_e^2}{4(R_e - 1.18\sigma_r)}$ [MPa] – in other cases; (13.5.3.6-3)

l, s – see 13.1.2.

13.6 Simple Primary Supporting Members

13.6.1 General Requirements

The structure of simple primary supporting members and the scantlings of their structural parts shall comply with the below specified requirements within the scope of:

- minimum thickness, see 13.2,
- section modulus, see 13.6.2,
- web cross-sectional area, see 13.6.3,
- buckling strength, see 13.6.4.

13.6.2 Section Modulus

13.6.2.1 The section modulus of a primary supporting member, subjected to lateral load, shall be calculated including effective plate flange, determined in accordance with 3.2.2, about the neutral axis parallel to the plating. The net section modulus, i.e. after deduction of corrosion additions in accordance with 2.5, if required, shall not be less than that determined in accordance with the following formula:

$$W = \frac{1000 l^2 b p}{m \sigma} \quad [\text{cm}^3] \quad (13.6.2.1-1)$$

l, b, p – see 13.1.2;

σ – allowable stress determined as follows:

- for the continuous longitudinal primary supporting members amidships:

$$\sigma = 190k - 130f \frac{z_n - z_a}{z_n} \quad [\text{MPa}] \quad (13.6.2.1-2)$$

however not more than $160k$ [MPa];

- for the longitudinal primary supporting members in peaks:

$$\sigma = 160k \quad [\text{MPa}]$$

The value of σ varies linearly between the above specified regions;

- for transverse and vertical girders:

$$\sigma = 160k \quad [\text{MPa}]$$

m – bending moment factor (see 5.2.3.3), in general $m = 10$ may be taken.

13.6.2.2 Design values of W may be determined in accordance with the requirements specified in paragraph 13.5.2.5.

13.6.3 Web Cross-section Area

13.6.3.1 Effective web cross-section area of primary supporting member subjected to the lateral load, determined in accordance with 3.2.3, shall not be less than:

$$A = \frac{c k_1 l b p}{k} + 0.01 h_s t_k \quad [\text{cm}^2] \quad (13.6.3.1)$$

$c = 0.75$ – for web of watertight bulkhead primary supporting members (not applicable to the collision bulkhead);

$c = 1.0$ in other cases;

$k_1 = 0.06$ – for continuous horizontal primary supporting members, as well as upper ends of vertical primary supporting members of sides and bulkheads;

$k_1 = 0.08$ – for lower ends of vertical primary supporting members of sides and bulkheads;

$k_1 = 0.07$ – for deck primary supporting members;

l, b, p, h_s, t_k – see 13.1.2.

13.6.3.2 The web cross-section area in the middle of the span shall not be less than half the value determined in accordance with formula 13.6.3.1.

13.6.4 Buckling Strength of Primary Supporting Members

13.6.4.1 The buckling strength of primary supporting members subjected to axial loads (pillars and cross-ties) shall be checked in accordance with 13.7.3 and 13.7.4.

13.6.4.2 The buckling strength of primary supporting members subjected to transverse loads and possible additional axial loads due to the hull girder bending shall comply with the following requirements:

- lateral buckling strength of the whole girder need not, in general, be checked;
- it is assumed that the requirements regarding torsional buckling of primary supporting members and local buckling of flanges are complied with if the requirements of 3.6.2 and 3.6.4 are satisfied;
- primary supporting member webs shall comply with local buckling strength criteria, specified in 13.3.2.2, 13.3.2.3 or 13.3.2.5 for design stress value determined in accordance with 13.3.2.7 or 13.3.2.10. Their stiffening or strengthening in accordance with the requirements specified in sub-chapter 3.6.3 may be required for that purpose.

13.6.4.3 For primary supporting members – supporting longitudinal stiffeners (deck beams, frames, longitudinal bulkhead stiffeners) or primary supporting members supporting other stiffeners subjected to axial compression stresses, the moment of inertia of primary supporting member cross-section (including effective plate flange) shall not be less than:

$$I = 0.3 \frac{l_w^4 I_u}{b^3 s} \quad [\text{cm}^4] \quad (13.6.4.3-1)$$

l_w – span of the primary supporting member, [m],

b – distance between primary supporting members, [m];

s – spacing of stiffeners, [m];

$I_u = \frac{\sigma_E A l^2}{0.001 E}$ [cm⁴] – moment of inertia of compressed stiffener cross-section, necessary to fulfil

the requirements specified in 13.5.3.2;

$$\sigma_E = 1.18 \sigma_r \text{ if } \sigma_r \leq 0.5 R_e \quad (13.6.4.3-2)$$

$$\sigma_E = \frac{R_e^2}{4(R_e - 1.18 \sigma_r)} \text{ [MPa] - in other cases;} \quad (13.6.4.3-3)$$

σ_r – the compressive stress in the stiffener, [MPa];

A – cross-section area of stiffener, see 13.5.3.2, [cm²];

l – span of stiffener, [m].

13.7 Pillars and Supporting Members

13.7.1 Application

The requirements of the present sub-chapter apply to members subjected to compressive axial stresses: deck pillars, vertical stiffeners and bulkhead primary supporting members supporting deck structures, panting beams in peaks and cross-ties in tanks.

13.7.2 General Requirements

13.7.2.1 As far as practicable, the deck pillars shall be fitted in line with the upper and lower pillars.

13.7.2.2 Transverse web beams in decks and platforms of machinery spaces shall be fitted in line with side web frames and deck pillars to form stiff frame structures.

13.7.3 Pillars and Supporting Stiffeners

13.7.3.1 The critical buckling stress σ_c of pillars, cross-ties and panting beams, determined in accordance with the requirements specified in 13.5.3 and 13.3.2.2, shall be not less than:

$$\sigma = \frac{10P}{Ak_1} \text{ [MPa]} \quad (13.7.3.1-1)$$

P – axial load, as specified in 13.7.3.2, 13.7.4 or obtained from direct stress analysis in accordance with Chapter 14, [kN];

$$k_1 = \frac{k_2}{1 + \frac{l}{i}}, \text{ however, not less than 0.3;} \quad (13.7.3.1-2)$$

$k_2 = 0.5$ – for supporting members of weather deck within $x \geq 0.4L_0$, as well as for cross-ties and panting beams in side tanks and peaks;

$k_2 = 0.6$ – for supporting members of weather deck when sea loads are applied;

$k_2 = 0.7$ – in other cases;

$i = \sqrt{\frac{I_\alpha}{A}}$ – radius of gyration of cross-section of the supporting member, [cm];

I_α, A – see 13.5.3.2;

l – span of a pillar, cross-tie or panting beam.

13.7.3.2 The nominal axial force in deck pillars shall be determined in accordance with the following formula:

$$P = \sum P_i \text{ [kN]} \quad (13.7.3.2)$$

P_i – force transmitted to the considered pillar from deck i [kN].

The force transmitted from deck primary supporting members shall be taken equal to half the sum of lateral forces acting on primary supporting members supported by the considered pillar.

13.7.4 Cross-ties and Panting Beams

The required cross-sectional area of cross-ties in tanks and panting beams in peaks shall be determined in accordance with 13.7.3.1, taking $k_2 = 0.5$ and the axial force determined in accordance with the following formula:

$$P = lb p \text{ [kN]} \quad (13.7.4)$$

l – mean span of a primary supporting member or frame supported by a cross-tie or panting beam, [m];

b – the breadth of the plating supported by a primary supporting member or frame, see 3.2.2.3, [m].

13.8 Brackets

13.8.1 Application

The requirements specified in this sub-chapter apply to brackets connecting stiffener and primary supporting member ends to other structures.

13.8.2 Bracket Ends of Stiffeners

13.8.2.1 All types of stiffeners shall be connected at their ends with brackets. In special cases, bracketless connections or snipped ends of stiffeners may be allowed (see 13.8.2.7 and 13.8.2.8).

Brackets of overlap type (see items (a) and (b) in Fig. 13.8.2.3) shall generally be applied only at locations where the bending moment capacity required for the bracket is reduced compared to the bending moment capacity of the stiffener. It means that brackets of overlap type are generally permitted at upper ends of side frames and vertical stiffeners of bulkheads.

13.8.2.2 Where continuity of strength of longitudinals members is provided by bracketed connections with primary supporting members or transverse bulkheads, the alignment of the brackets on each side of the primary supporting member shall be ensured. The scantlings and design of the brackets shall be such that the combined stiffener/bracket (or the bracket alone where the stiffener end is not welded to the primary supporting member/bulkhead) section modulus and effective cross-section area are not less than those of the member. PRS may require calculations of fatigue strength for such type hull structure nodes, according to the requirements of *Publication 45/P – Fatigue Strength Analysis of Steel Hull Structure*.

13.8.2.3 The scantlings of the brackets for stiffeners not taking part in the longitudinal strength shall fulfil the requirements specified in 13.8.2.4 to 13.8.2.8 (see also Fig. 13.8.2.3 and 3.2.1.1).

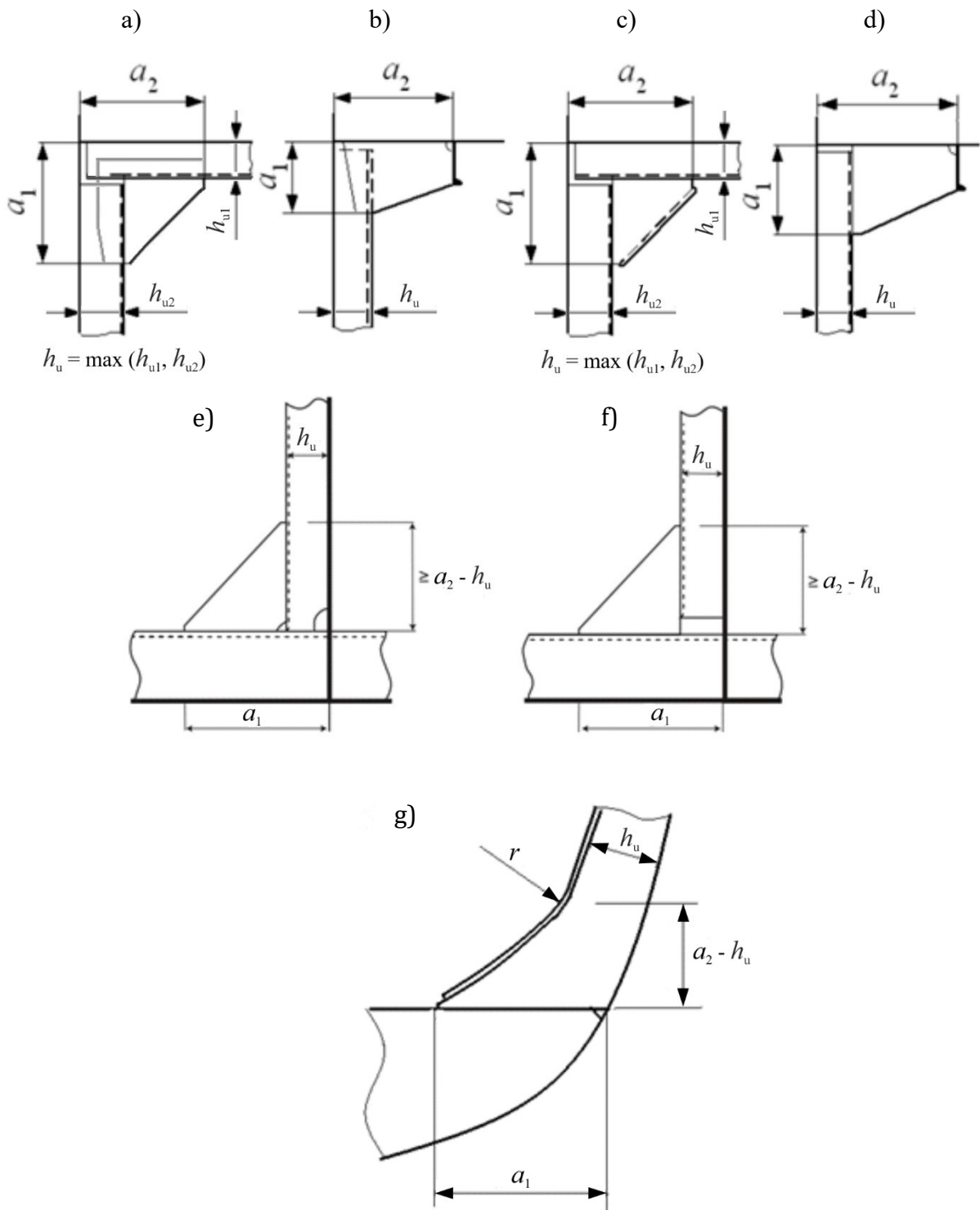

Fig. 13.8.2.3. Bracket ends of stiffeners

13.8.2.4 The net thickness of the bracket t_w shall be not less than determined from the formula:

$$t_w = (2 + k_1 \sqrt{W}) \sqrt{\frac{R_{e-u}}{R_{e-w}}} \quad [\text{mm}] \quad (13.8.2.4)$$

W – rule net section modulus for the stiffener (the minimum value if more than one stiffener have been attached to the bracket), [cm³];

$k_1 = 0.2$ for flanged brackets;
 $k_1 = 0.3$ for unflanged brackets;
 R_{e-w} – yield strength of bracket material, [MPa];
 R_{e-u} – yield strength of stiffener material, [MPa].

The bracket thickness t_w shall not be less than 6.

If the stiffener end is not welded to plating or flange of the second stiffener (see items a), b), c), d) and f) in Fig. 13.8.2.3, the net bracket thickness shall also not be less than the net web thickness of the non-continuous stiffener and the material yield strength of the bracket shall not be less than that of the stiffener.

13.8.2.5 The bracket arm length a shall be not less than determined from the formula:

$$a = c \sqrt{\frac{W}{t_w}} \quad [\text{mm}] \quad (13.8.2.5-1)$$

W, t_w – in accordance with 13.8.2.4;

a – see a_1 and a_2 Fig. 13.8.2.3 and further requirements specified in this paragraph;

$c = 65$ for flanged brackets;

$c = 70$ for unflanged brackets.

The adopted value of a shall also be not less than:

- a) $1.8h_u$ – for connections where the ends of the stiffeners are welded with each other or with plating and the bracket is in line with stiffener webs (or with offset necessary to enable welding) – as in the items e) and g) in Fig. 13.8.2.3 (value h_u in [mm] – see Fig. 13.8.2.3.);
- b) $2.2h_u$ – for other cases of stiffener connections (as in items a), b), c), d) and f) in Fig. 13.8.2.3);
- c) $2h_u$ – for cases where plating stiffener is connected to a primary supporting member of bulkhead (see vertical stiffeners in items f).

In the case of different arm lengths a_1 and a_2 , their sum shall not be less than $2a$ and the length of the smaller arm shall not be less than $0.8a$ (see Fig. 13.8.2.3).

For bracket connection as in item d) in Fig. 13.8.2.3 (bracket edge connected with the stiffener flange), the dimension a_1 shall be not less than h_u and a_2 – not less than $0.8a$.

For stiffener ended with an integral bracket, the radius r (see item g) in Fig. 13.8.2.3) shall be not less than:

$$r = 1.6 \frac{b_1^2}{t_m} \quad [\text{mm}] \quad (13.8.2.5-2)$$

where:

b_1 – the distance between flange and web (greater value of two distances in case of an angle of asymmetrical flange), [mm];

t_m – flange thickness, [mm].

Where the length of free edge exceeds $50t_w$, a flange or edge stiffener shall be fitted, its width b being taken not less than that calculated in accordance with the following formula:

$$b = 45 \left(1 + \frac{W}{2000} \right) \quad [\text{mm}] \quad (13.8.2.5-3)$$

and not less than 50 mm.

W – see 13.8.2.4.

13.8.2.6 The arrangement of the connection between plating stiffener and the bracket shall be such that at no point in the connection (bracket cross-section) is the section modulus to be less than that required for the stiffener.

13.8.2.7 Bracketless end connections may be applied for longitudinals and other stiffeners running continuously through primary supporting members (web frames, web deck beams, bulkheads), provided sufficient welded joints are arranged (for longitudinals see also 6.2.2.2 and 8.2.2).

13.8.2.8 Stiffeners with snipped ends may be allowed where dynamic loads are small and where vibrations shall be considered to be of small importance, provided the thickness of plating supported by the stiffeners is not less than calculated in accordance with the following formula:

$$t = 1.25 \sqrt{\frac{(l-0,5s)p}{k}} \quad [\text{mm}] \quad (13.8.2.8)$$

l – stiffener span, [m];

s – stiffener spacing, [m];

p – pressure acting on plating supported by stiffener in question, [kPa].

The distance of the snipped ends of stiffeners to the web of primary supporting member, deck plating, bulkhead, etc., shall not exceed double thickness of plating and 40 mm. The depth of the snipped end of the stiffener shall not exceed its thickness, but need not be less than 15 mm.

13.8.3 End Connections of Primary Supporting Members

13.8.3.1 Ends of primary supporting members or connections between primary supporting members forming frame systems shall be provided with brackets.

The free edges of the brackets shall be rounded with a radius or well rounded at their toes and flanged.

Bracketless connections may be applied, provided adequate support of adjoining face plates is arranged.

13.8.3.2 The thickness of the primary supporting member brackets shall not be less than that of the primary supporting member web plate.

Primary supporting member brackets shall have along their free edges the face plates with cross-sectional area not less than:

$$A_{mw} = l_w t_w \quad [\text{cm}^2] \quad (13.8.3.2)$$

l_w – length of free edge of bracket, [m];

If l_w exceeds 1.5 m, the bracket shall be fitted with an additional stiffener parallel to the face plate and maximum 0.15 m from the edge, the cross-sectional area of the face plate being equal to 60% of the value determined from the above formula and the cross-sectional area of the stiffener equal to 40% of this value;

t_w – thickness of bracket, [mm].

Where face plate of the primary supporting member is continuous with the bracket face plate, the change in face plate dimensions shall, as far as possible, be gradual. Where there is a discontinuity between the face plates, the face plate of the primary supporting member shall extend well beyond the toe of the bracket.

13.8.3.3 The bracket arm length, including the primary supporting member depth shall be determined in accordance with the following formula:

$$a_w = c \sqrt{\frac{W}{t_w}} \quad [\text{mm}] \quad (13.8.3.3)$$

W – the required section modulus of the primary supporting member connected with the bracket, [cm³];

t_w – bracket thickness, [mm];

$c = 63$ for bracket of bottom and deck primary supporting members,

$c = 88$ in other cases.

Other values of c may be accepted after PRS consideration in each particular case.

13.8.3.4 Normal stresses in mid length of the bracket free edge shall not exceed the allowable stresses specified in 14.4 increased by:

- 25% for structures where the bracket with stiffened edge is welded to the face plates of connected primary supporting members,
- 45% for structures where the bracket is an integral part of both girders, its face plate being an extension of the primary supporting member face plates.

13.8.3.5 At cross joints of bracketless connections, the required flange area of face plate may be gradually tapered beyond the crossing flange. For flanges in tension, the allowable tensile stress shall be reduced when lamellar tearing of flanges may occur.

The thickness of the primary supporting member web at cross joints of bracketless connection (see Fig. 13.8.3.5) shall not be less than the greater value determined from the following formulae:

$$t_3 = \frac{\sigma_1 A_1}{k_t h_2} - \frac{\tau_2 t_2}{k_t 100} \quad [\text{mm}] \quad (13.8.3.5-1)$$

$$t_3 = \frac{\sigma_2 A_2}{k_t h_1} - \frac{\tau_1 t_1}{k_t 100} \quad [\text{mm}] \quad (13.8.3.5-2)$$

A_1, A_2 – minimum required flange cross-sectional area of primary supporting members 1 and 2, respectively, [cm²];

h_1, h_2 – height of primary supporting members 1 and 2, [mm];

t_1, t_2 – minimum required thicknesses (outside region 3) of primary supporting member 1 and 2 web plates, [mm];

σ_1, σ_2 – bending stresses in primary supporting members 1 and 2, [MPa];

τ_1, τ_2 – shear stresses in webs of primary supporting members 1 and 2, [MPa];

k_t – material factor for corner web plate (region 3) of the web.

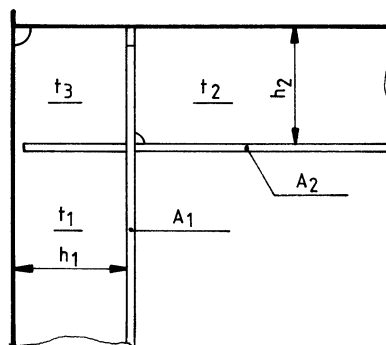

Fig. 13.8.3.5. Bracketless connection of primary supporting members

14 ZONE, GENERAL AND LOCAL STRENGTH, THE PRINCIPLES OF FINITE ELEMENTS METHOD CALCULATIONS

14.1 General

14.1.1 Application

14.1.1.1 The requirements of the present Chapter are applicable to:

- strength analysis of the hull primary supporting members system;
- global hull strength analysis in cases where the strength assessment in accordance with the requirements of Chapter 15 cannot be performed (e.g. in ships with superstructures located amidship, ships with large hatchway openings in deck, etc.);
- hull stiffeners strength assessment in cases where the methods and criteria given in 13.5 cannot be applied, as well as to the assessment of stress level in stress concentration areas (e.g. brackets, edges of openings, cut-outs, etc.).

The calculated stress values may be applied for buckling strength analysis of the plating, primary supporting member webs and stiffeners – according to the criteria given in 13.3.2 and 13.4.3.

14.1.1.2 Cases where the stress analysis shall be carried out are specified in the following Chapters:

- 18 – for container ships,
- 19 – for ro-ro ships,
- 20 – for bulk carriers,
- 21 – for tankers.

14.2 Design Load Conditions

14.2.1 Stress analysis shall be conducted for the most severe but realistic load conditions, with the ship:

- fully loaded,
- partly loaded,
- ballasted (tank cleaning procedures to be taken into consideration),
- loading / discharging.

For sea conditions, realistic combinations of external and internal dynamic loads, as specified in Chapter 16, shall be considered. For harbour conditions, the dynamic loads may be neglected. The mass of deck structures may be neglected when it is less than 5% of the design loads.

Recommendations on design load conditions are also given in Chapters listed in paragraph 14.1.1.2.

14.3 Hull Primary Supporting Members System Strength Assessment on the Basis of Beam FE Models

14.3.1 Application

14.3.1.1 The term „beam FE models” means models in the form of continuous beams, flat frames and three-dimensional frames.

Such models may be used for zone strength analysis of the hull structure modules consisting of flat or almost flat, stiffened fragments of the plating, strengthened with primary supporting members (such as side shell, bottom, decks, bulkheads), which can be considered as slender.

14.3.1.2 The zone strength analysis of the structure with strongly variable shapes (such as the hulls without middle body or end parts of the hulls) shall be made in accordance with the requirements of sub-chapter 14.4.

14.3.2 Structure Modelling Principles

14.3.2.1 Beam elements of FE model shall, in general, be located at the neutral axis of the considered section.

In the case of T beams welded to the shell plating, location of elements in a line of the web contact with the plating is permitted.

14.3.2.2 FEM calculations with the use of beam elements shall be made in a linear-elastic range, having regard to deformations due to bending, shear, torsion, tension and compression.

14.3.2.3 Strength characteristics of the transverse sections the model elements (section area, moment of inertia, section moduli, torsional rigidity) shall be determined for net thicknesses of structural members, i.e. after deduction of corrosion additions according to 2.5.

14.3.2.4 Moment of inertia and section moduli of the primary supporting members shall be calculated for the web with the effective flange or flanges (in the case of double skin structures).

The width of the effective flange shall be determined in accordance with 3.2.2. Stiffeners located within the effective flange may be considered in accordance with the requirements of 3.2.2.1.

The flanges of T-shaped primary supporting members shall be considered in their entirety.

14.3.2.5 Within the web openings, the shear area shall be taken as an effective web section area determined in accordance with 3.2.3.

14.3.2.6 Torsional constant for the T primary supporting members (Fig. 14.3.2.6 a) shall be determined from the formula:

$$I_0 = \frac{1}{3} \sum_{i=1}^3 l_i t_i^3 \quad (14.3.2.6-1)$$

Torsional constant for the primary supporting members in double skin structures shall be determined from the formula:

$$I_0 = \frac{b_m \cdot h_s^2}{\frac{1}{t_1} + \frac{1}{t_2}} \quad (14.3.2.6-2)$$

Thicknesses t_1 and t_2 in the above formulae are the net thicknesses of the plating.

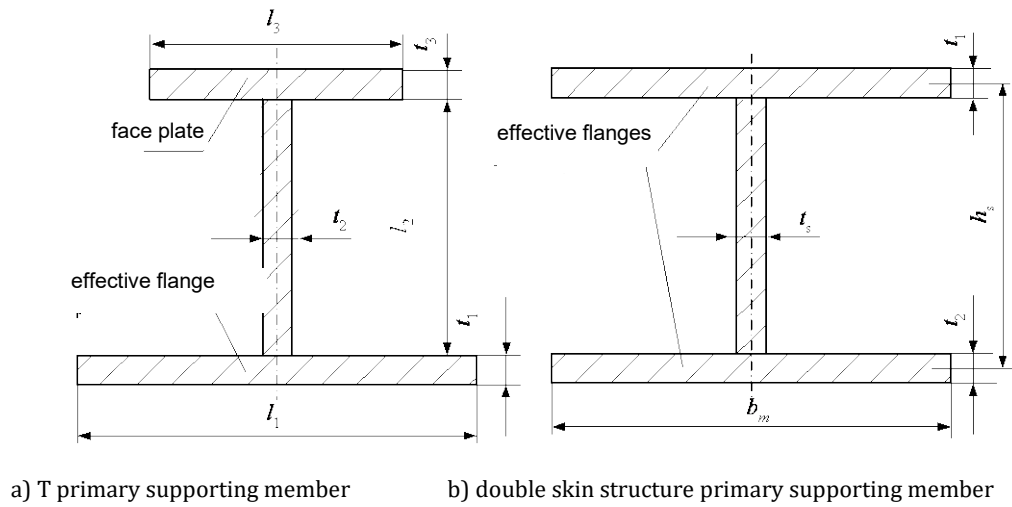

Fig. 14.3.2.6

14.3.2.7 In way of brackets and the crossings of primary supporting members, rigid beam elements (or rigid ends of elements – if the program allows) with the lengths determined according to Fig. 14.3.2.7 shall be used.

Strength characteristics of the rigid elements shall be determined as follows:

- moment of inertia shall be assumed 100 times the moment of inertia of average elements with finite rigidity, used in a given model,
- section area and shear section area shall be assumed 10 times the relevant section area of average elements with finite rigidity, used in a given model.

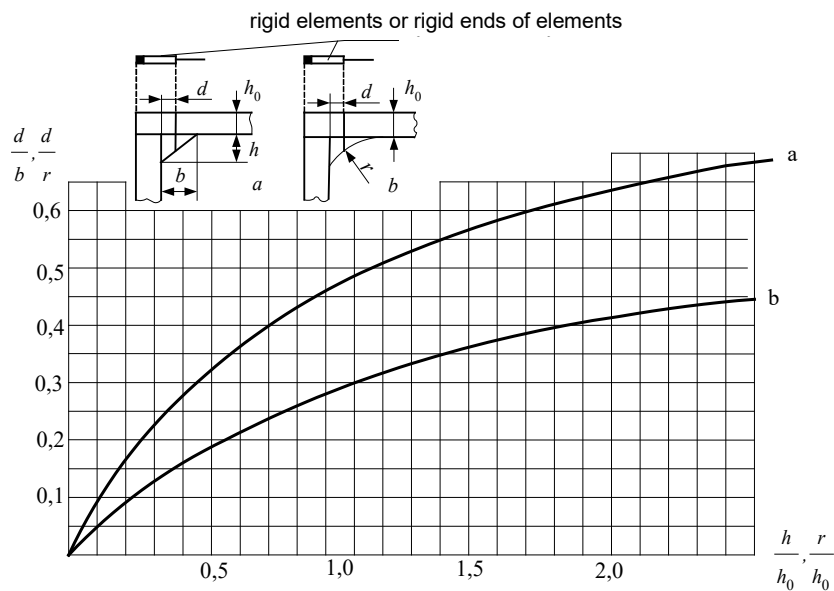

Fig. 14.3.2.7. Determining the lengths of rigid elements or rigid ends of elements

14.3.3 FE Model Loads

14.3.3.1 FE model loads due to water pressure, liquid stores or the load of stores on decks shall be applied to beam elements in the form of a continuous load having the following value:

$$q = p \cdot b \quad (14.3.3.1)$$

where:

p – design pressure

b – width of the supported plating strake (equal to half the distance between adjacent primary supporting members, bulkheads, etc).

14.3.3.2 The load from equipment, containers, etc., may, in general, be applied in the form of concentrated forces at FE model nodes.

14.3.3.3 On the boundary of FE model, loads in the form of concentrated forces and moments resulting from the loads acting on the hull structure outside the region covered by the FE model, shall be applied.

14.3.4 Boundary Conditions

14.3.4.1 FE model nodes may, in general, be supported non-displaceably in a vertical direction, in the planes of sides, transverse and longitudinal bulkheads, vertical divisions.

14.3.4.2 On the boundary of FE model, the correlation between the considered fragment of the structure and the rest of the hull – in the form of appropriate springs connected to the model nodes shall be taken into account.

14.3.4.3 FE model may span a fragment of the hull structure on one side of the plane of symmetry. In such case, under symmetrical load, appropriate boundary conditions in the plane of symmetry (naught rotation angles of the nodes around longitudinal and vertical axes) shall be applied.

14.3.5 Permissible Stresses

Permissible values of stresses in primary supporting members corresponding to design loads determined in accordance with Chapter 16 are given in 14.5.

14.3.6 Report on FEM Calculations

14.3.6.1 Calculations Data

The report on FEM calculations shall contain the following information concerning the applied input data:

- arrangement of beam elements (drawing of the model – generated, e.g. by the computer program – and co-ordinates of the nodes);
- sections of beam elements and values of their strength characteristics (strength and section moduli, etc.), assumed for calculations;
- applied loads;
- applied boundary conditions;
- material properties (Young's modulus, Poisson's coefficient, yield point).

14.3.6.2 Calculation Results

The calculation results shall include:

- drawing of the deformed structure (computer print) and the maximum values of the nodes displacement;
- values of stresses in particular elements of FE model.

14.4 Hull Primary Supporting Member System Strength Assessment on the Basis of FE Models Using Membrane, Shell and Beam Finite Elements

14.4.1 Application

14.4.1.1 The requirements of sub-chapter 14.4 apply to the assessment of hull primary supporting member system strength with the use of 3D finite FE models (applying membrane, shell and beam finite elements).

14.4.1.2 FE model shall cover a sufficiently large module of the hull structure – in the form of imposed boundary conditions – so as to minimize, in the region where the strength of primary supporting members is assessed, the influence (on the results of the calculations) of inaccurate modelling of the correlation between the primary supporting members used in FE model and the remaining primary supporting members.

The minimum required extent of FE model shall span the hull module from the centre of the compartment between watertight bulkheads to the centre of such adjacent compartment. For symmetrical hull and the symmetry of the load, the FE model spanning a fragment of the structure – from CP to one side, may be applied.

It is advisable, however, to develop a FE model spanning three successive compartments between watertight bulkheads. In such case, only the stresses in the middle compartment of the module, including transverse bulkheads, will be subject to assessment.

14.4.1.3 The calculation results of FE model required in 14.4.1.2 may be utilized as the boundary conditions for the local FEM strength analysis in accordance with the requirements specified in 14.7.

14.4.2 Principles of Structure Geometry Modelling

14.4.2.1 The principles of modelling, presented below, refer to FEM calculations in a linear-elastic range, with the use of models, in which 4-node membrane or shell finite elements and 2-node rod or beam elements are applied.

The application of higher order elements (8-node or 6-node) allows, in general, to employ a more coarse division into finite elements than that required below. Such models are subject to a separate consideration of PRS.

The application of 3-node triangular elements shall be avoided. Such elements may be used in exceptional cases only so as to avoid unacceptable shapes of quadrangle elements.

14.4.2.2 In FE model, all primary supporting members in the considered hull module (including brackets and the bracket webs stiffeners), the plating and the plating stiffeners shall be taken into account.

The net thicknesses of structural members shall be applied, i.e. corrosion additions, required in 2.5, shall be deducted.

To determine the effective area A_e for curved webs of primary supporting members or curved plating (e.g. at the bilge) according to 3.2.2.4 and 3.2.2.5, their reduced effectiveness in bending condition shall be considered using reduced plate thickness.

14.4.2.3 The stiffeners of the plating may be modelled using one row of shell or membrane finite elements at the height of the web; face plates may be modelled by rod elements.

Alternatively, the stiffeners of the plating in the form of 2-node beam non-axial elements, i.e. the elements in which the stiffener neutral axis displacement in relation to the plating has been taken into account, may be considered.

Where the computer program does not allow to apply such elements, the modelling of stiffeners in the form of 2-node rod elements in the plane of the plating is permitted. However, section areas of such elements shall be suitably reduced in relation to the section areas of stiffeners to correctly represent the bending stiffness of the primary supporting member with the stiffened belts of the plating. The principle of modelling non-continuous stiffeners is given in 14.4.2.4.

14.4.2.4 The primary supporting member face plates and stiffeners applied to ensure stability of the primary supporting member webs may be considered in the form of 2-node rod elements. In the case of curved face plates, the requirements of 14.4.2.2 shall apply.

If the primary supporting member face plates or stiffeners of the primary supporting member webs are not continuous (the ends are sloped), then, for the end sections of these elements, over the length not less than the 2 times the face plate thickness or the stiffener height, the reduced value of their cross-section shall be taken in the FE model. This value shall be equal to 25% of the mean value of the actual section area along the length of the finite element.

14.4.2.5 When developing FE models of the plating, the primary supporting member webs and brackets with the use of membrane or shell elements, the following principles shall be observed:

- the ratio of the length of the longer quadrangle element side to the shorter side length shall not, in general, exceed 2, and in no case shall be greater than 4;
- the angle between the sides of the element shall be in a range of 60° to 120°;
- the angles of triangle elements (if their application cannot be avoided) shall be in a range of 30° to 120°.

14.4.2.6 When developing FE model of the plating, the division into finite elements shall be such that the size of the elements will be not greater than that given by the following minimum requirements:

- at the height of the primary supporting member webs, at least 3 finite elements shall be applied and the web division into elements shall be adjusted to the arrangement of the web stiffeners;
- when dividing the hull shell plating, the plating of decks and bulkheads into finite elements, at least one finite element between adjacent stiffeners shall be applied; along the ship length, the length of the finite elements sides shall not be greater than the frame spacing.

14.4.2.7 Openings in the primary supporting member webs in FE model shall be considered in accordance with the below principles, depending on the height h of the structural member, the height h_0 and the length b_0 of the opening, the spacing e_0 between the adjacent openings (see Fig. 14.4.2.7), as well as the proportion of these dimensions characterized by the value c_0 :

$$c_0 = 1 + \frac{b_0^2}{2.6(h - h_0)^2} \quad (14.4.2.7-1)$$

The opening may be neglected in FE model when $h_0/h < 0.35$ and $c_0 < 1.2$.

In FE model in way of the opening shown in Fig. 14.4.2.7, the reduced thickness of the plating shall be applied:

$$t_1 = \frac{h - h_0}{h} t_s \quad (14.4.2.7-2)$$

(t_s – net thickness of the web), when $0.35 \leq h_0/h < 0.5$ and $c_0 < 1.2$.

In FE model in way of the opening shown in Fig. 14.4.2.7, the reduced thickness shall be applied:

$$t_2 = \frac{t_1}{c_0} \quad (14.4.2.7-3)$$

(t_1 and c_0 defined above), when $0.35 \leq h_0/h < 0.5$ and $1.2 \leq c_0 < 2$.

When $h_0/h \geq 0.5$ or $c_0 \geq 2$, the opening shall be directly considered in the FE model.

When the distance e_0 between adjacent openings is less than $0.25h$, the dimension b_0 shall be interpreted according to Fig. 14.4.2.7 c) (the web area in which openings in the FE model are considered covers the whole area of adjacent openings).

If, according to the above principles, the opening is not considered in the FE model, the stresses calculated by the FE method shall be corrected in accordance with 14.5.2.2 before they are compared with permissible values, specified in 14.5.3.

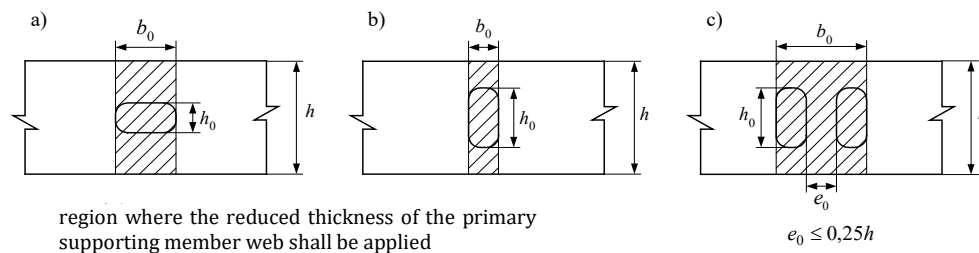

Fig. 14.4.2.7. Dimensions of openings in the primary supporting member web

14.4.2.8 The primary supporting member brackets shall be directly considered in the FE model. The length of finite elements sides in way of such brackets shall not be greater than 250 mm; in each case, at least 3 finite elements shall be placed along the free edge of the bracket. If the end of the bracket face plate is not connected to the face plate (or plating) of the primary supporting member, the lack of this connection shall be represented in the FE model and for the end parts of the face plate, the reduced value of cross-sectional area shall be used – in accordance with 14.4.2.4.

14.4.3 Design Loads

14.4.3.1 Scope of Calculations

Calculations shall be performed for the most severe but realistic load conditions, with the ship:

- fully loaded,
- partly loaded,
- ballasted (tank cleaning procedures to be taken into consideration),
- loading / discharging.

For sea conditions, realistic combinations of external and internal dynamic loads, as specified in Chapter 16, shall be considered. For harbour conditions, the dynamic loads may be neglected. The mass of deck structures may be neglected when it is less than 5% of the design loads.

Guidelines for design loads of certain ship types specified are also given in Chapters 18 to 21, as well as in Publications: *Publication 17/P – Zone Strength Analysis of Hull Structure of Roll on/Roll off Ship*, *Publication No. 18/P – Zone Strength Analysis of Bulk Carrier Hull Structure*, *Publication 19/P – Zone Strength Analysis of Hull Structure in Tankers* and *Publication 24/P – Strength Analysis of Container Ship Hull Structure*.

The loads shall be applied to FE model in a way described in paragraphs 14.4.3.2 and 14.4.3.3.

14.4.3.2 Local Loads

If the plates of the plating are modelled by shell elements and the stiffeners have bending stiffness, then the load from sea water acting on the hull and the loads from liquid cargo or bulk cargo, ballast water or liquid stores and general cargo loads from inside the hull may be imposed on FE model in the form of pressures.

The load from containers or large cargoes shall be applied in the form of concentrated forces at the point of their supports.

If the plates of the plating are modelled by membrane elements, then the loads listed above shall be applied in the form of continuous loads in the plane of stiffener webs of primary supporting members. The value of the continuous load is equal to the value of the pressure multiplied by the width of the supported strake of the plating.

14.4.3.3 Global Loads

The term “global loads” refers to inner forces in the hull due to general bending or torsion.

In the FE model spanning 3 successive compartments between watertight bulkheads, the vertical hull bending moments having the values $M = M_s + M_{wr}$, determined according to 15.1.1.2, 15.4 and 15.5, shall be considered.

The value of M shall be reduced to obtain the design value of M_{obl} moment:

$$M_{obl} = M \frac{W_{netto}}{W} \quad (14.4.3.3-1)$$

where:

M – as defined above;

W – the value of section modulus determined for design net thicknesses of structure elements according to the principles given in sub-chapter 15.7;

W_{netto} – the value determined analogously to W but for the net thicknesses of the structure elements (see 14.3.2.3).

Bending moments to be applied to the end transverse sections of the hull module, described above, shall be such that the value of M_{obl} moment will be obtained in the hull transverse section located in the centre of the length of the hull module middle compartment.

The method of bending moments application to the end transverse sections of the hull module is specified in 14.4.4.1.

The value of M_0 of these moments is as follows:

$$M_0 = M_{obl} - M_{lok} \quad (14.4.3.3-2)$$

where:

M_{obl}, M_0 – as defined above,

M_{lok} – the value of bending moment due to local bending of the hull module; the value of M_{lok} shall be calculated using a beam model having the length of the hull module, simply supported in transverse bulkheads planes at the ends of the module and subject to a

continuous load corresponding to the vertical component of local loads determined in 14.4.3.2.

14.4.4 Boundary Conditions

14.4.4.1 Boundary Conditions for the Hull Module Spanning 3 Successive Watertight Compartments

Flat end cross-sections of the hull module shall be enforced by applying, in each of the cross sections, independent nodes (at the neutral axis on CP) rigidly linked with all nodes of the plates, longitudinal stiffeners plating and longitudinal primary supporting members lying in the same cross-section (dependent nodes).

The boundary conditions are as follows:

on the aft end of the model:

- the zero values of independent node displacements in the y and z directions (the co-ordinate system is defined in paragraph 17.2.1);
- the use of rigid connections between dependent nodes and an independent node in the x , y and z directions;

on the bow end of the model:

- the zero values of independent node displacements in the x , y and z directions and the zero value of its angle of rotation around the x -axis;
- the application of rigid connections between dependent nodes and independent nodes in the x , y and z directions.

If FE model spans only a half of the structure, from CP to the ship's sides, then the zero values of angles of rotation around the x and z axes, as well as the zero displacement of all nodes lying in CP in the y -axis direction shall be enforced.

At both ends of the model, the values of M_0 , determined according to 14.4.3.3, shall be applied to independent nodes.

14.4.4.2 Boundary Conditions for the Hull Module Spanning Half the Length of the Successive Watertight Compartments

Upon agreement with PRS, the symmetry conditions in the end cross-sections of the hull module may be applied, i.e. all nodes lying in the planes of these sections before the FE model deformation shall remain in the planes perpendicular to the x -axis after the model deformation (the coordinate system axes are shown in Fig. 17.2.1).

In all nodes on the ship's sides, at the upper deck, the zero values of vertical displacements may normally be enforced.

If the FE model spans only a half of the structure, from CP to the ship's side, the zero values of angles of rotation around the x and z axes and the zero displacements of all nodes lying in CP in the y -axis direction shall be enforced.

Normal stresses due to M moment (see 14.4.3.3) shall be considered in accordance with 14.5.2.1.

14.4.4.3 Boundary Conditions for the Remaining FE Models

Where FE models of the fragments of the structure having the scantlings other than those determined in 14.4.4.1 and 14.4.4.2 are used, the applied boundary conditions will be assessed by PRS separately.

14.4.5 Report on FEM Calculations

14.4.5.1 Calculation Data

Report on FEM calculations shall include complete information concerning the applied input data.

In each case, the following information shall be given:

- the assumed thicknesses of plates (in the form of FE model coloured map or numerical values on the FE model background);
- transverse sections of the webs modelled by the rod elements;
- effective cross-section areas of the curved webs or equivalent thickness of the curved plating;
- parameters of the transverse sections of the beam elements;
- the applied boundary conditions (description or in a graphical form – on the FE model drawings);
- the applied loads (the form as above);
- material properties (Young's modulus, Poisson's coefficient, yield point).

14.4.5.2 Calculation Results

The calculation results report shall include:

- the drawing of the deformed structure with information on the maximum values of the nodes displacements;
- the values of the normal, shear and equivalent stresses in particular FE model membrane or shell elements – in the form of a coloured map or numerical values on the FE model background.

14.5 Assessment of Stress Level in Primary Supporting Members

14.5.1 Application

The values of permissible stresses given in the present sub-chapter are applicable to the calculations performed in accordance with the requirements of 14.3 and 14.4.

In the case of calculations performed according to 14.4, the requirements of sub-chapter 14.5.2 relating to interpretation of the calculated stresses shall be taken into account.

14.5.2 Interpretation of the Stresses Calculated with the Use of Membrane or Shell FE Models

14.5.2.1 Normal stresses σ , subject to assessment, are membrane stresses. In the case of shell elements, reference stresses are internal plane stresses (the stresses in the middle of the plates thickness).

If the FE model does not span three successive compartments between watertight bulkheads, i.e. it is shorter (see 14.4.1.2), then, upon agreement with PRS, normal stresses due to general bending, determined from the formula:

$$\sigma(z) = \frac{M}{I} \cdot \frac{W_{netto}}{W} (z - z_0) \quad (14.5.2.1)$$

where:

M , W_{net} , W – defined in 14.4.3.3;

I – moment of inertia of the hull cross-section (see 15.7);

z – vertical coordinate (see Fig. 17.2.1);

z_0 – coordinate of the hull cross-section neutral axis;

may be algebraically added to normal stresses σ_x (acting along the hull) of the determined FE models.

The stresses so calculated shall be compared with permissible values specified in 14.5.3.

14.5.2.2 Shear stresses τ in the primary supporting member webs, subject to assessment, are mean stresses, calculated for the effective section area of the web with openings according to 3.2.3 (see also 14.4.2.7).

14.5.2.3 Equivalent stresses shall be calculated from the formula:

$$\sigma_{zr} = \sqrt{\sigma_x^2 + \sigma_y^2 - \sigma_x \sigma_y + 3\tau^2} \quad [\text{MPa}] \quad (14.5.2.3)$$

where:

- x, y – axes of the local co-ordinate system;
- σ_x – normal stresses in the x -axis direction;
- σ_y – normal stresses in the y -axis direction;
- τ – shear stresses in the xy plane

14.5.2.4 Where finite elements having constant stress values in way of the element are used, consideration of the actual stresses variation in way of the element may be required.

In such cases, linear interpolation may be applied assuming that computer program calculates the values of stresses in the middle of finite elements.

14.5.2.5 In the structure regions where the stress level exceeds 75% of the permissible values given in 14.5.3, FEM calculations of the stresses and the stress level assessment in these areas according to the principles specified in 14.7 may be required by PRS.

Fatigue strength analysis of such areas according to *Publication 45/P – Fatigue Strength Analysis of Ship Steel Hull Structure* may be also required.

14.5.3 Values of Permissible Stresses

14.5.3.1 For primary supporting members, which do not transfer stresses due to general bending or the hull torsion (such as transverse, vertical primary supporting members, etc.), the values of the permissible stresses are as follows:

- $\sigma = 160k$ [MPa] (in the direction of the primary supporting member axis);
- $\tau = 90k$ [MPa], for the primary supporting member webs with one effective flange or for the plating;
- $\tau = 100k$ [MPa], for the primary supporting member webs with two effective flanges or for the plating;
- $\sigma_{zr} = 180k$ [MPa], for the primary supporting member webs, face plates or the plating.

Where a tensile stress is acting perpendicular to the plane of the plate (e.g. at the inner bottom or top of stool tank), its value shall not exceed $100k$ [MPa] unless the plate material used is specially treated to obtain high resistance to lamellar tearing and is of suitable grade (see 2.2.2).

14.5.3.2 For primary supporting members transferring normal stresses due to general bending or torsion (longitudinal primary supporting members), the values of the permissible stresses are as follows:

- in accordance with 14.5.3.1, where stresses due to general bending or the hull torsion are disregarded;
- $\sigma = 190k$ [MPa] – the permissible value of the total normal stresses in primary supporting members due to zone bending and general bending or torsion; for calculations, 0.59 of the M_w value, determined according to 15.5 (see 15.1.1.2) shall be taken if the hull torsion is disregarded.

The hull torsion shall be taken into account in the case of ships with large openings in deck. In such cases, the values of bending and torsional moments shall be taken in accordance with *Publication 24/P – Strength Analysis of Container Ship Hull Structure*.

14.5.3.3 The permissible value of normal stresses in the middle of the free edge of the primary supporting member bracket, along the bracket edge, is 200k [MPa].

The above requirement applies to all primary supporting members. In the case of longitudinal primary supporting members, both load variants, required in 14.5.3.2, shall be considered.

14.5.3.4 For longitudinal stiffeners of the bottom plating, the inner bottom, sides, decks, longitudinal bulkheads, etc., the criterion expressed in the form of formula 14.7.3.3 shall be complied with.

14.5.3.5 The values of the permissible stresses given in 14.5.3.1÷14.5.3.4 concern loads in sea conditions, determined according to Chapter 16.

For harbour conditions (loading operations) and for ship repair conditions, the values of the permissible stresses may be increased by 10% with respect to those given above.

14.6 Assessment of the Hull General Strength with the Use of FE Method

14.6.1 Application

14.6.1.1 In cases where calculations according to Chapter 15, based on beam hull model, cannot be applied for the assessment of the hull general strength, FEM calculations using membrane – rod or shell – rod model, in accordance with the requirements of sub-chapter 14.6, shall be performed.

Such calculations may be required by PRS in the case of ships with long superstructures in the central part or in the case of a non-typical hull structure.

In the case of ships with wide hatch openings, the analysis of the hull torsional strength according to the requirements of *Publication 24/P – Strength Analysis of Container Ship Hull Structure* shall be carried out.

14.6.1.2 The assessment of the hull general strength may be performed with the use of FE model in accordance with the requirements of 14.4.1.2, applied for the zone strength analysis. In such case the gross scantlings of structure elements, i.e. without deduction of corrosion additions, shall be used. It will be sufficient, however, to use the FE model which complies with the requirements specified in 14.6.2.

14.6.2 Requirements for FE Models

14.6.2.1 The assessment of the hull global strength shall be performed for the gross scantlings of structural members, e.g. without deduction of corrosion additions.

14.6.2.2 The FE model shall correspond to the hull module in the middle part of the ship, spanning three successive compartments between watertight bulkheads.

The use of FE model having different length will be specially considered by PRS.

14.6.2.3 FE model shall precisely enough represent rigidity of the structure.

The minimum requirements concerning the division of the structure into finite elements are as follows:

- longitudinal stiffeners of the side plating, decks and longitudinal bulkheads, etc., may be modelled in the form of rods located in planes of plates stiffened by the stiffeners and grouped into several pieces;
- the primary supporting member webs may be divided into finite elements in such a way that at the height of the web there is only one finite element;
- the primary supporting member face plates may be modelled by rod elements;
- side plating may, in general, be divided into finite elements in such a way that there is only one row of finite elements between adjacent primary supporting members;
- cut-outs in primary supporting members, through which plating stiffeners pass and other small cut-outs and openings can be neglected in division of the structure into the finite elements;
- access holes in the primary supporting members shall be considered – in the regions, where such openings are located, equivalent plate thickness may be applied in the FE model in such a way that the value of the cross-section of the web with an opening will be maintained.

Note: In the case of structure considered by PRS as non-typical, the application of a more precise FE model may be required.

14.6.2.4 Membrane or shell finite elements shall comply with the requirements of 14.4.2.5.

14.6.3 Loads and Boundary Conditions

14.6.3.1 Assessment of Normal stresses due to Bending Moment

Flat cross-sections at the ends of the hull module (see 14.6.2.2) shall be enforced by applying boundary conditions for displacements identical to those specified in paragraph 14.4.4.1.

For independent nodes (see 14.4.4.1) in the end cross-sections, the extreme value of bending moment:

$$M = M_s + M_w \quad (14.6.3.1)$$

which occurs in an interval equal to the hull module length, shall be applied.

The value of M_s and M_w shall be determined according to 15.4 and 15.5.

The structure local loads may be neglected (see also 14.6.3.4).

In cases considered by PRS as non-typical, PRS may require that boundary conditions other than those specified above shall be used. PRS may also require that FEM calculations of the entire hull should be performed.

14.6.3.2 Assessment of Shear Stresses due to Vertical Shear Force

Boundary conditions for displacements are identical to those specified in 14.6.3.1.

To independent nodes (see 14.4.4.1) in the end cross-sections, the extreme values of vertical shear force shall be applied:

$$Q = Q_s + Q_w \quad (14.6.3.2-1)$$

in the interval equal to the hull module length and bending moments:

$$M = \frac{1}{2} Q l_m \quad (14.6.3.2-2)$$

where:

l_m – the hull module length.

The values of Q_s and Q_w shall be determined according to 15.9. The values of Q_s may take into account correction of the shear force curve according to 15.12.

The way of Q and M application is shown in Fig. 14.6.3.2.

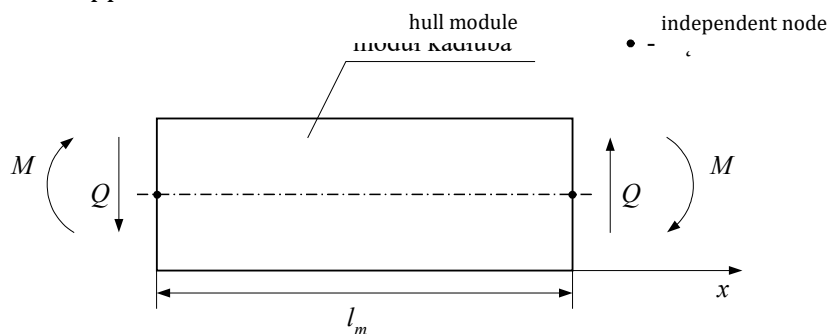

Fig. 14.6.3.2. Hull module loads

14.6.3.3 Consideration of the Symmetry of the Hull

Where the hull module subject to strength assessment is symmetrical with respect to the ship's CP, the FE model may comprise only a fragment of the structure – from CP to the ship's side.

In such case, the zero values of the angles of rotation around the x and z axes, as well as the zero values of displacements of the nodes lying in CP in the y -axis direction shall be enforced.

14.6.3.4 Consideration of Structure Local Loads

In FE model of the hull module, the Rule values of structure local loads may be considered.

In such case, in order to consider internal forces in the hull module regarded as a beam simply supported at the ends, appropriate modification of the value of M at the ends of the hull module in relation to the values required in 14.6.3.1 and 14.6.3.2 and the value of Q required in 14.6.3.2 will be required.

The design values of $M = M_s + M_w$ and $Q = Q_s + Q_w$ (i.e. complying with the requirements of Chapter 15) shall be obtained in the middle part of the hull module.

14.6.4 Permissible Stresses

14.6.4.1 The stress level $\sigma = \sigma_x$ in the plating of the bottom, deck, continuous hatchway coamings, etc. as well as the shear stress τ level in the plating of the sides, inner sides, longitudinal bulkheads, etc. shall be assessed separately.

The above stresses are the stresses in the centres of shell (or membrane) finite elements, in the neutral (central) layer.

The permissible values of the above stresses are identical to those specified in Chapter 15:

$$\sigma = 175 k \text{ [MPa]} \quad (14.6.4.1-1)$$

$$\tau = 110 k \text{ [MPa]} \quad (14.6.4.1-2)$$

14.6.4.2 In stress concentration areas, the stress values calculated by computer program may normally exceed the values determined in 14.6.4.1. Such cases are subject to special consideration of PRS.

14.6.5 Report on FEM Calculations

14.6.5.1 Report on FEM calculations in the same scope as that specified in 14.4.5 shall be prepared.

14.7 Assessment of Stress Level in Stress Concentration Areas and in the Plating Stiffeners (Local FE Models)

14.7.1 Application

The assessment of stress level on the basis of local FE models may be required by PRS for the ship's hull regions where the calculations of the hull primary supporting member system strength made according to 14.4 show the equivalent stress level exceeding $135 k$, [MPa], i.e. 75 % of the permissible values (see 14.5.2.5).

This refers, in particular, to primary supporting member crossing, the ends of brackets, openings in primary supporting members, etc.

Checking the stress level in parts of longitudinal stiffeners of the bottom plating, decks, longitudinal bulkheads adjacent to transverse bulkheads or divisions may be also required. Bending of transverse primary supporting members adjacent to transverse bulkheads or divisions may induce significant stresses in stiffeners supported by these primary supporting members.

14.7.2 Requirements for FE Models in Stress Concentration Areas

14.7.2.1 Extent of FE Model

FE model using adequately small finite elements (see 14.7.2.2) shall normally cover the region around the stress concentration area (e.g. the bracket ends, the edges of opening or cut-outs in a primary supporting member, etc.).

In the FE model, at the area of the highest stress concentration, at least 10 rows of finite elements having the scantlings as specified in 14.7.2.2 shall be applied in all directions. Outside this region, the scantlings of finite elements may be gradually reduced.

An example of a proper division into finite elements of the structure in way of the end of the primary supporting member bracket is shown in Fig. 14.7.2.1 (only the structure on one side of the symmetry plane is shown).

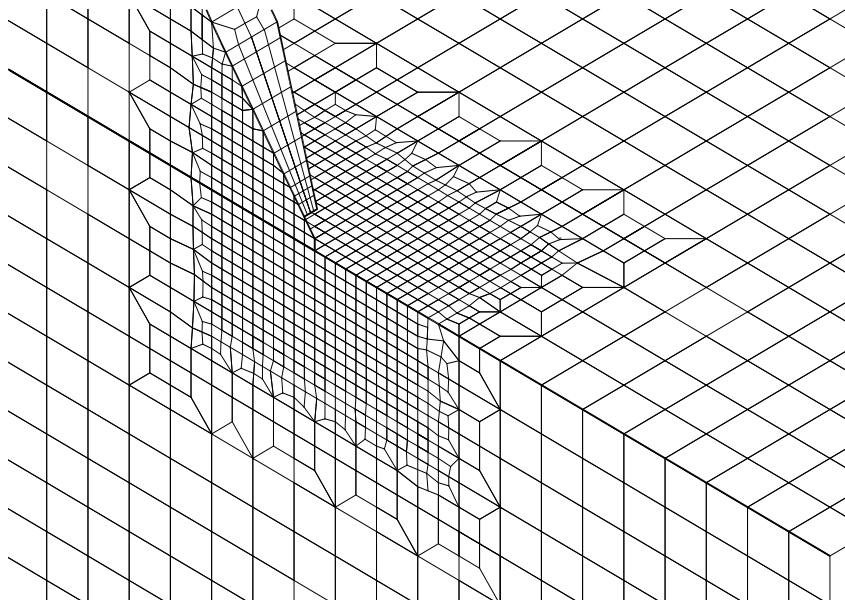

Fig. 14.7.2.1 An exemplary division of the structure into finite elements

For the assessment of stress level on the edges of cut-outs or openings in primary supporting members, the application of 2 rows of finite elements having the maximum scantlings, specified in 14.7.2.2, will be sufficient.

The boundaries of the local FE model shall be in line with the walls of primary supporting members (floors, transverse web frames, etc.) used in FE models, described in 14.4.

The boundary conditions according to the requirements of 14.7.2.3 shall be applied.

Alternatively, a local FE model may form an integral part of the model required in 14.5.

14.7.2.2 Finite Elements

The walls and flanges of primary supporting members or the plating stiffeners in stress concentration areas shall be modelled by shell finite elements.

The maximum scantlings of these structural elements within close proximity of the highest stress concentration area shall not be greater than 50 mm x 50 mm.

For the width of the primary supporting member flanges, stiffeners of the plating or the edges of openings, not less than 3 rows of finite elements shall be used.

The shape of the applied finite elements shall comply with the requirements set forth in 14.4.2.5.

14.7.2.3 Boundary Conditions and Loads

Where a separate local FE model is used (i.e. a model which is not an integral part of the primary supporting member system FE model, described in 14.4), then the values of displacements obtained from the FE model calculations shall be enforced on the nodes located on the model edge.

Alternatively, general forces resulting from the calculations of the primary supporting member system FE model may be applied to the above-mentioned nodes.

If the local FE model boundaries contain nodes, which do not occur in the primary supporting member system FE model (see 14.4), then the values of displacements obtained by linear interpolation, used for nodes displacements in the primary supporting member system FE model (14.4), shall be enforced on the local FE model nodes.

Local loads used in the primary supporting member system FE model (14.4), acting within the local FE model, shall be applied for the local FE model.

14.7.2.4 Stress Level Assessment

The stress level assessment refers to equivalent stresses in the middle layer of shell elements, in the centres of these elements.

Where finite elements having the maximum scantlings, specified in 14.7.2.2 (50 mm x 50 mm) are used, the permissible value of equivalent stresses is 310 k [MPa].

The assessment of stress level in stress concentration areas may be performed using FE models having the dimensions smaller than those specified above (e.g. models used for determining geometrical stresses of the hull structure applied to fatigue strength assessment – according to *Publication 45/P – Fatigue Strength Analysis of Ship Steel Hull Structure*). In that case the permissible value of equivalent stresses, specified above, refers to average stresses in any area with dimensions 50 mm x 50 mm. The average value shall be calculated for equivalent stresses in the centres of finite elements which are entirely included in the area having the dimensions 50 mm x 50 mm. This area shall not include parts of plates having different thicknesses.

14.7.3 Requirements for FE Models of the Plating Stiffeners

14.7.3.1 Extent of FE Model and Finite Elements

The FE model shall comprise a fragment of the structure having the length equal to at least two transverse primary supporting members spacings on each side of transverse bulkhead or division and the width equal to at least two spacings of stiffeners on each side of the stiffener subject to strength assessment.

At least 3 rows of shell finite elements shall be applied at the height of the stiffener web and on the face plate width.

The size and shape of finite elements used in stress concentration area subject to strength assessment, as well as the minimum dimensions of the area in which finite elements with reduced scantlings are to be used shall comply with requirements specified in 14.7.2.1 and 14.7.2.2.

An exemplary division into finite elements of the double bottom longitudinal stiffeners in way of their connection with transverse bulkhead is shown in Fig. 14.7.3.1.

14.7.3.2 Boundary Conditions and Loads

The requirements analogous to those, specified in 14.7.2.3, shall apply.

14.7.3.3 Stress Level Assessment

For stress concentration areas, the criteria analogous to those specified in 14.7.2.4 apply.

For longitudinal stiffeners of the bottom plating, the inner bottom, sides, decks, longitudinal bulkheads, etc. the condition, given below, shall be additionally satisfied:

$$\sigma \leq 220 k \text{ [MPa]} (14.7.3.3)$$

where:

σ – normal stress in the stiffener face plates, determined for the FE model complying with the requirements of sub-chapter 14.4, taking into account hull general bending or torsion – in accordance with the requirements set forth in 14.5.3.2.

14.7.4 Report on FEM Calculations

For FEM calculations specified in 14.7.2 and 14.7.3, a report, in the same scope as described in 14.4.5, shall be prepared.

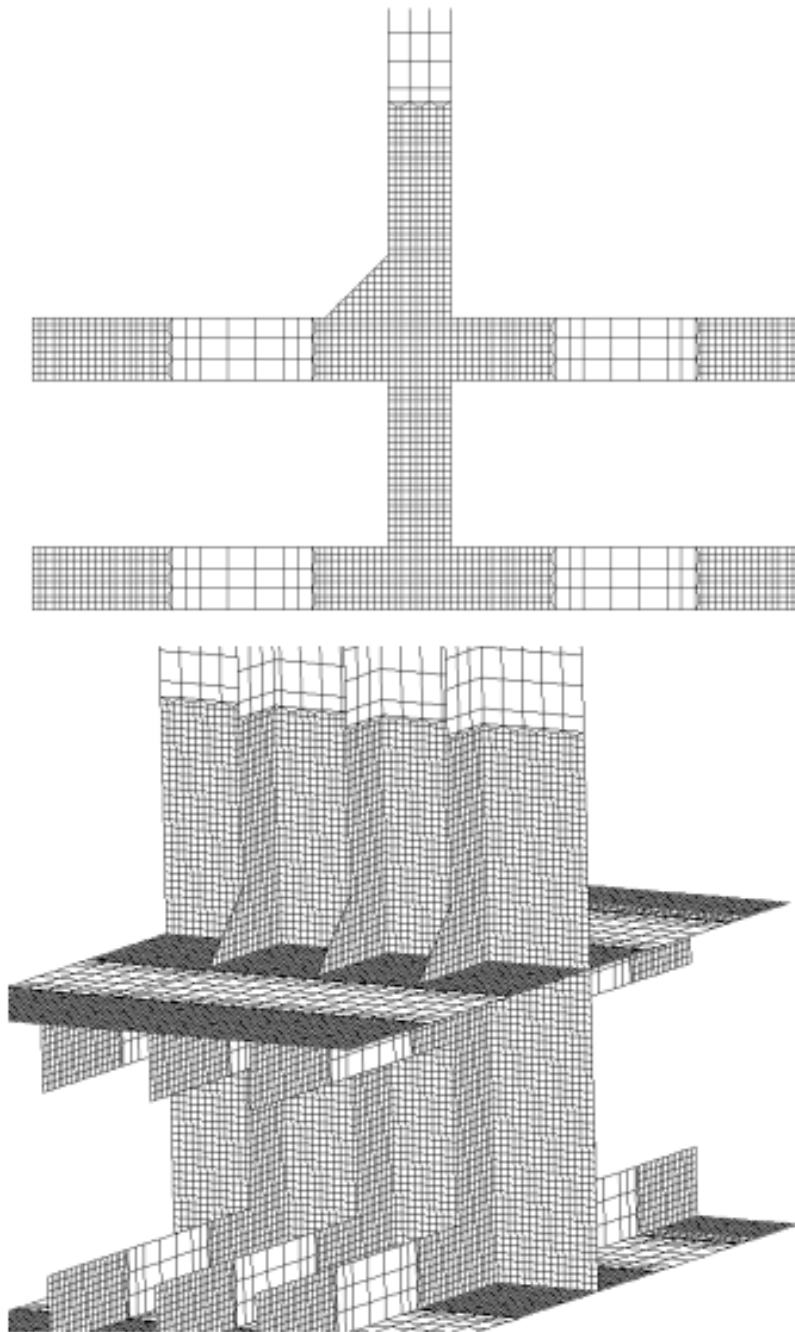

Fig. 14.7.3.1. An exemplary FE model of the double bottom stiffeners in way of the transverse bulkhead region

15 LONGITUDINAL STRENGTH

15.1 General

15.1.1 Application

15.1.1.1 The final scantlings of the longitudinal hull structure members, which shall comply with the requirements of local strength (Chapter 13) and zone strength (sub-chapters 14.3 or 14.4) of the hull structure shall also satisfy the requirements of hull girder bending and shear strength given in the present Chapter. These requirements apply to steel ships intended for navigation in unrestricted area except containers carriers with a length of 90 m and greater and except bulk carriers and oil tankers subjected to requirements of CSR.

15.1.1.2 Ships having one or more features given below are subject to PRS consideration in each particular case:

- main dimensions ratios: $L_0 / B < 5$; $B/H > 2.5$,
- $L_0 > 500$ m,
- block coefficient $\delta < 0.6$,
- large deck openings,
- carriage of heated cargoes,
- unusual design.

Strength calculations with the use of FE model – according to the provisions of sub-chapter 14.6, may be required.

15.1.1.3 The values of the wave bending moments and shear forces applied in the present Part of the *Rules* correspond to the values which can be exceeded with probability equal to 10^{-8} . Values in this form are applied at determining the required section modulus and shear cross-sectional area of the hull, as well as at checking the buckling and ultimate strength of the hull. In other cases, where wave hull bending stresses are combined with stresses determined on the basis of zone or local strength analysis of the structure, the Rule values of wave bending moments and shear forces may be reduced to the following values:

$$M_{wr} = 0.59M_w \text{ [kNm]} \quad (15.1.1.2-1)$$

$$Q_{wr} = 0.59Q_w \text{ [kN]} \quad (15.1.1.2-2)$$

M_w – vertical wave bending moment, [kNm], determined in accordance with 15.5;

Q_w – wave component of hull shear force, [kN], determined in accordance with 15.10.

The modified values of wave hull loads correspond with the values of allowable stresses determined in present Part of the *Rules*.

15.1.1.4 The scantlings of the longitudinal members taking part in the longitudinal strength of the hull girder shall comply with the requirements for buckling strength specified in 13.3.

15.1.1.5 For ships with small block coefficient, high speed and large flare, the section modulus in the forebody may have to be specially considered by PRS based on the distribution of still water and wave bending moments along the ship's length, determined in accordance with 15.4 and 15.5. Such procedure is obligatory for ships with length $L_0 > 120$ m and speed $v > 17$ knots.

15.1.1.6 Longitudinal strength of relatively small breadth ships shall comply with the requirements of 15.2.4, taking into account the combined effects of vertical and horizontal bending of the hull girder.

15.1.1.7 For ships with large deck openings, the combined effects of hull girder bending, shear and torsion related to local bending and shear stresses may have to be taken into account. The way of determining the above-mentioned stresses is specified in *Publication 24/P – Strength Analysis of Container Ship Hull Structure*.

15.1.1.8 Additional requirements for the scantlings of hull structural members may be given, taking into consideration specific features of the ship regarding the load conditions and structure.

15.1.1.9 Hull strength assessment shall take into account the assumed changes of the ship ballasting on a voyage which result in the hull load change.

15.1.2 Definitions

C_w – wave coefficient, as specified in 17.2.2;

I_n – moment of inertia of the hull girder cross-section for the transverse neutral axis, [cm⁴];

M_s – design still water bending moment, [kNm];

M_w – vertical wave bending moment, [kNm];

Q_s – design still water shear force, [kN];

Q_w – design wave shear force, [kN];

S_n – first moment of area of the longitudinal structure members above or below the horizontal neutral axis, taken about this axis, [cm³];

z_n – vertical distance from the base plane or deck line to the neutral axis of the hull girder, whichever is relevant, [m];

τ – allowable shear stress, [MPa];

σ – allowable bending stress, [MPa].

15.1.3 Explanations

Loading Manual is a document which describes:

- the loading conditions on which the design of the ship has been based, including permissible limits of still water bending moment and shear force;
- the results of the calculations of still water bending moments, shear forces and, where applicable, limitations due to torsional and lateral loads;
- the allowable local loading for the structure (hatch covers, decks, double bottom, etc.).

Loading Instrument is an instrument, either analogue or digital (computer system), by means of which it can be easily and quickly ascertained that, at specified read-out points, the still water bending moments, shear forces and the still water torsional moments and lateral loads, where applicable, in any load or ballast condition will not exceed the specified permissible values.

Category I ships

- ships with large deck openings where combined stresses due to vertical and horizontal hull girder bending and torsional and lateral loads shall be considered;
- ships liable to carry non-homogeneous loadings, where the cargo and/or ballast may be unevenly distributed. Ships of $L_0 < 120$ m, when their design takes into account uneven distribution of cargo or ballast, belong to Category II;
- chemical tankers and gas carriers.

Category II ships – ships with arrangement giving small possibilities for variation in the distribution of cargo and ballast, and ships on regular and fixed trading pattern where the Loading Manual gives sufficient guidance, and in addition the exceptions given under Category I.

15.2 Hull Section Modulus

15.2.1 The section modulus about the horizontal neutral axis, determined in accordance with sub-chapter 15.7 for cargo and ballast conditions, shall not be less than:

$$W = \frac{(M_s + M_w)}{\sigma} \cdot 10^3 \quad [\text{cm}^3] \quad (15.2.1)$$

M_s – hull still water bending moment, calculated in accordance with 15.4, [kNm];

M_w – hull wave bending moment, determined in accordance with 15.5, [kNm];

$\sigma = 175k$ [MPa], within $-0.2L_0 \leq x \leq +0.2L_0$,

$\sigma = 105k$ [MPa], within $x \leq -0.4L_0$ and $x \geq +0.4L_0$.

Between the specified regions, the value of σ varies linearly. In each case the hull girder section modulus W shall comply with the requirements specified in 15.2.2.

15.2.2 The midship section modulus related to the deck and the keel shall not be less than:

$$W_o = \frac{C_{wo}}{k} L_0^2 B (\delta + 0.7) \quad [\text{cm}^3] \quad (15.2.2)$$

The value of δ shall not be taken less than 0.6.

Values of C_{wo} are as follows:

- for ships with length $L_0 \geq 90$ m: $C_{wo} = C_w$, C_w – see 17.2.2;
- for ships with length $L < 90$ m: $C_{wo} = 5.7 + 0.022 L_0$, however, not less than 7.0;
- for ships of restricted service, the coefficient C_{wo} may be reduced:
 - by 5% for service area **II**,
 - by 15% for service area **III**
- for service areas corresponding to marks Class C and Class D it is enough to fulfill the requirement of paragraph 15.2.1.

For atypical constructions, the reduction percentage is subject to PRS consideration in each particular case.

The minimum value of section modulus shall be generally maintained within $-0.2L_0 \leq x \leq +0.2L_0$. It may be, however, gradually reduced from the midship towards fore and aft end of ship, provided the stresses due to still water and wave bending moments do not exceed the values allowed for the middle part of the ship.

15.2.3 In slender ships it may happen that to keep the required section modulus within the end regions of the middle part of the ship it would be necessary to increase scantlings of hull longitudinal members within these regions.

In such cases PRS may accept not increased scantlings, provided the scantlings of the members and their material groups are kept unaltered within the whole midship body and the proper tapering of material and structural member scantlings towards the ends of the ship is made.

15.2.4 In ships with the length $L_0 \geq 90$ m, the midship section modulus about the vertical neutral axis shall not be less than that calculated in accordance with the following formula:

$$W_{oh} = \frac{5}{k} L_0^{9/4} (T + 0.3B) \delta \quad [\text{cm}^3] \quad (15.2.4-1)$$

The above requirement may be disregarded, provided the equivalent stresses due to vertical and horizontal hull bending at bilge and deck corners are proved to be within 195k [MPa]. The equivalent stress may be determined in accordance with the following formula:

$$\sigma_e = \sigma_s + \sqrt{\sigma_w^2 + \sigma_{wh}^2} \quad [\text{MPa}] \quad (15.2.4-2)$$

σ_s – stress due to M_s moment (see sub-chapter 15.4.1), [MPa];

σ_w – stress due to M_w moment (see sub-chapter 15.5.1), [MPa];

σ_{wh} – stress due to M_{wh} moment (see sub-chapter 15.5.3), [MPa].

In ships with large openings in the strength deck, departure from this requirement (formula 15.2.4-1) is possible, provided that normal stresses in the hull, determined in accordance with *Publication 24/P – Strength Analysis of Container Ship Hull Structure*, with hull torsion taken into account, do not exceed $195k$ [MPa].

15.2.5 The scantlings of longitudinal members outside amidships may be gradually reduced to the scantlings determined by the local strength for the ship ends. In the cases specified in 15.1.1 or determined by the ship structural design, special consideration of the hull section modulus in other places along the ship's length may be required.

As a minimum, hull girder bending strength checks shall be performed outside amidships at the following locations:

- in way of the forward end of the engine room,
- in way of the forward end of the foremost cargo hold,
- at any locations where there are significant changes in hull cross-section,
- at any locations where there are changes in the framing system.

Buckling strength of members contributing to the longitudinal strength and subjected to compressive and shear stresses shall be checked, in particular in regions where changes in the framing system or significant changes in the hull cross-section occur. The buckling evaluation criteria used for this check is determined in Chapter 13.

Continuity of structure shall be maintained throughout the length of the ship. Where significant changes in structural arrangement occur adequate transitional structure shall be provided.

For ships with large deck openings, sections at or near to the aft and forward quarter length positions shall be checked. For such ships with cargo holds aft of the superstructure, deckhouse or engine room, strength checks of sections in way of the aft end of the aft-most holds, and the aft end of the deckhouse or engine room shall be performed.

15.3 Moment of Inertia of Hull Cross-section

The moment of inertia of the ship's hull cross-section amidships shall not be less than:

$$I_n = 3C_w L_0^3 B(\delta + 0.7) \quad [\text{cm}^4]. \quad (15.3)$$

15.4 Still Water Bending Moment

15.4.1 General

15.4.1.1 Still water bending moments M_s and shear forces Q_s shall be calculated at each section along the ship length for design cargo and ballast loading conditions, specified in 15.4.2. For ships of length $L_0 \geq 90$ m, the design values of M_s and Q_s shall be taken as the maximum values obtained from the above calculation, having regard to the requirements specified in 15.4.3.

For these calculations, downward loads shall be taken as positive values and shall be integrated in the forward direction from the aft end of L . The sign conventions of bending moments and shear forces are as shown in Fig. 15.4.1.1.

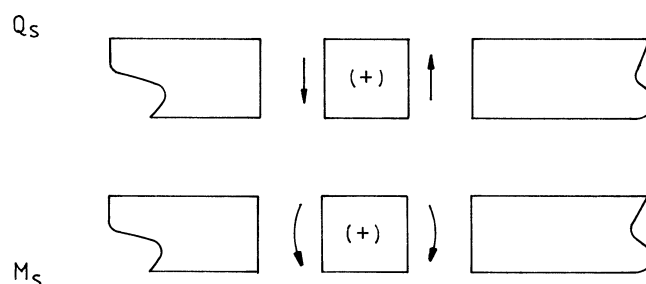

Fig. 15.4.1.1. Sign conventions of M_s and Q_s

15.4.2 Design Loading Conditions

15.4.2.1 In general, the design cargo and ballast loading conditions, specified in 15.4.2.3, shall be taken into account.

The realistic homogeneous and non-homogeneous, full and part loading conditions, realistic amounts of bunker, fresh water and stores at departure and arrival, including ballast and tank cleaning conditions in tankers, as well as docking conditions shall be taken into account.

15.4.2.2 Where the amount and disposition of consumables at any intermediate stage of the voyage are considered more severe, calculations of M_s and Q_s for such intermediate conditions shall be made in addition to those required for departure and arrival conditions.

Where any ballasting or deballasting is intended during voyage, the values of M_s and Q_s calculated for the intermediate condition just before and just after ballasting (or deballasting) any ballast tank shall be taken into account.

The above loading conditions shall be included in the *Loading Manual*.

15.4.2.3 Loading conditions to be considered for different ship types:

- .1** General cargo ships, ro-ro ships, refrigerated carriers, bulk carriers, ore carriers:
 - homogeneous loading condition at maximum draught,
 - ballast conditions,
 - special loading conditions, e.g. light load conditions at less than the maximum draught, heavy cargo, empty holds or non-homo-geneous cargo conditions, deck cargo conditions, etc., where applicable,
 - short voyage or harbour conditions, and
 - docking conditions afloat,
 - loading and unloading transitory conditions, where applicable,
- .2** Oil tankers:
 - homogeneous loading conditions (excluding clean and dry ballast tanks), ballast condition and part-loaded condition,
 - any specified non-uniform distribution of loading,
 - mid-voyage conditions relating to tank cleaning or other operations where these differ significantly from the ballast conditions,
 - docking conditions afloat,
 - loading and unloading transitory conditions.
- .3** Chemical tankers:
 - loading conditions, as specified for oil tankers,
 - loading conditions for high density or heated cargo, as well as segregated cargo if such products are included in the approved cargo list.

- .4** Liquefied gas carriers:
- homogeneous loading conditions for all approved cargoes,
 - ballast conditions,
 - loading conditions where one or more tanks are empty or partially filled, or where more than one type of cargo having significantly different densities is carried,
 - harbour conditions, for which an increased vapour pressure has been approved,
 - docking conditions afloat.
- .5** Combination carriers:
- loading conditions, as specified in 1. and 2.

15.4.2.4 Ballast loading conditions involving partially filled peak and/or other ballast tanks at departure, arrival or during intermediate conditions are not permitted to be used as design conditions unless:

- design stress limits are satisfied for all filling levels between empty and full, and;
- for bulk carriers, the requirements specified in sub-chapter 20.6, as applicable, are fulfilled for all filling levels between empty and full.

To demonstrate compliance with all filling levels between empty and full, it will be acceptable if, in each condition at departure, arrival and where required in 15.4.2.3 any intermediate condition, the tanks intended to be partially filled are assumed to be:

- empty;
- full;
- partially filled at the intended level.

Where multiple tanks are intended to be partially filled, all combinations of empty, full or partially filled at intended level for those tanks shall be investigated.

For conventional ore carriers with large wing water ballast tanks in cargo area, where empty or full ballast water filling levels of one or maximum two pairs of these tanks (symmetrically against the ship's plane of symmetry) lead to the ship's trim exceeding one of the conditions specified in .1 and .2 or fulfilling the condition specified in .3, it is sufficient to demonstrate compliance with maximum, minimum and intended partial filling levels of these one or maximum two pairs of ballast tanks such that the ship's condition does not exceed any of these trim limits.

Filling levels of all other wing ballast tanks shall be considered between empty and full.

The trim conditions mentioned above are:

- .1** trim by stern of 3% of the ship's length, or
- .2** trim by bow of 1.5% of ship's length, or
- .3** any trim where propeller immersion ratio $I/D \geq 0.25$ is maintained (I , D – see Fig. 15.4.2.4).

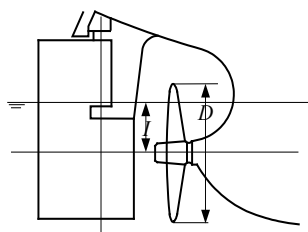

I – the distance from propeller centreline to the waterline

D – propeller diameter

Fig. 15.4.2.4

The maximum and minimum filling levels of the above mentioned pairs of side ballast tanks shall be indicated in the *Ship Loading Manual*.

Detailed guidance for application of the above-specified requirements is provided in *Part IV of Publication 16/P – Loading Guidance Information*.

15.4.2.5 In cargo loading conditions with partially filled ballast tanks, the requirements specified in paragraph 15.4.2.4 apply to the peak tanks only.

15.4.2.6 The requirements specified in paragraphs 15.4.2.4 and 15.4.2.5 are not applicable to ballast water exchange using the sequential method.

However, bending moment and shear force calculations for each deballasting or ballasting stage in the ballast water exchange sequence shall be included in the loading manual or ballast water management plan of any vessel that intends to employ the sequential ballast water exchange method.

15.4.3 Minimum Values of M_s

15.4.3.1 Design still water bending moment M_s amidships shall be taken as the maximum absolute value of the bending moments in accordance with 15.4.1 however not less than:

$$M_{so} = M_{sou} = -0.065C_w L_0^2 B (\delta + 0.7) \quad [\text{kNm}] \quad (15.4.3.1-1)$$

in sagging, and

$$M_{so} = M_{sow} = C_w L_0^2 B (0.1225 - 0.015\delta) \quad [\text{kNm}] \quad (15.4.3.1-2)$$

in hogging.

The value of block coefficient shall be taken as $\delta \geq 0.6$.

For ships with space arrangement giving small possibilities for variation of the distribution of cargo and ballast, the value of M_{so} may be dispensed with as the design basis for determining the scantlings of hull structural members.

15.4.3.2 The still water bending moments M_s at arbitrary position along the ship's length, when required for stress analysis or buckling control, shall be taken for each cross-section of the hull as the maximum value of M_s determined as the result of examination of loading conditions, specified in 15.4.1. The above values shall not be less than those determined in accordance with the following formula:

$$M_{sx} = k_{sm} M_{so} \quad [\text{kNm}] \quad (15.4.3.2)$$

M_{so} – see 15.4.3.1,

$k_{sm} = 1.0$ for the midship body: $-0.2L_0 \leq x \leq 0.2L_0$,

$k_{sm} = 0.15$ for sections: $x = -0.4L_0$ and $x = +0.4L_0$,

$k_{sm} = 0.0$ for sections: $x = -0.5L_0$ and $x = +0.5L_0$.

The value of k_{sm} shall be varied linearly between the above specified areas.

15.4.4 Bending Moment in Ships of Length $L_0 < 90$ m

The minimum value of still water bending moment shall be determined in accordance with the following formula:

$$M_s = M_{so} = 0.006 L_0^3 B (\delta + 0.7) \quad [\text{kNm}] \quad (15.4.4)$$

Where absolute value of still water bending moment M_{sl} , determined for ballast condition and, possibly, for conditions with non-homogeneous distribution of load along the ship's length, exceeds M_{so} , then $M_s = M_{sl}$ shall be taken.

The determined value of M_s is applicable within $-0.2L_0 \leq x \leq +0.2L_0$. Beyond this area, M_s may be linearly reduced to zero at $x = -0.5L_0$ and $x = +0.5L_0$.

15.5 Wave Bending Moment

15.5.1 Vertical Wave Bending Moment

The design vertical wave bending moment M_w amidships within $-0.1L_0 < x < +0.15L_0$ shall be taken as:

$$M_w = M_{wu} = -0.11 C_w L_0^2 B(\delta + 0.7) \quad [\text{kNm}] \quad (15.5.1-1)$$

for negative moment (sagging), and

$$M_w = M_{ww} = 0.19 C_w L_0^2 B\delta \quad [\text{kNm}] \quad (15.5.1-2)$$

for positive moment (hogging).

The following values shall be taken:

$\delta \geq 0.6$;

C_w – see 17.2.2.

For ships of restricted service, the values of M_w , calculated according to 15.5.1-1 and 15.5.1-2, may be reduced:

- by 10% for service area **II**;
- by 20% for service area **III**;
- by 35% for service area corresponding to mark Class C;
- by 50% for service area corresponding to mark Class D.

In harbour conditions, the values of the wave bending moment shall be taken equal to 40% of the values determined above for unsheltered waters and equal to 10% – for sheltered waters.

15.5.2 Distribution of M_w along Ship's Length

15.5.2.1 When values of the wave bending moments M_w at any position along the ship's length are required in connection with stress analysis or buckling control, the applied values M_{wx} shall not be less than the values determined in accordance with the following formula:

$$M_{wx} = k_{wm} M_w \quad [\text{kNm}] \quad (15.5.2.1)$$

M_w – defined in 15.5.1,

$k_{wm} = 1.0$ within $-0.1L_0 \leq x \leq 0.15L_0$ – for ships of $L_0 \geq 90$ m,

$k_{wm} = 1.0$ within $-0.1L_0 \leq x \leq 0.1L_0$ – for ships of $L_0 < 90$ m,

$k_{wm} = 0.0$ in sections $x = -0.5L_0$ and $x = +0.5L_0$.

The value of k_{wm} shall be varied linearly between the midship and end areas (see Fig. 15.5.2.2).

15.5.2.2 For ships with high speed or large flare in the forebody, an adjusted value of k_{wm} shall be taken in formula 15.5.2.1 within $x \geq +0.1L_0$. The adjustment depends on the value of parameters $C_a = C_{av}$ and $C_a = C_{af}$, whichever of the adjusted values of k_{wm} is the greater.

$$C_{av} = \frac{C_v v}{\sqrt{L_0}} \quad (15.5.2.2-1)$$

$$C_{af} = \frac{C_v v}{\sqrt{L_0}} + \frac{F_{pd} - F_{wd}}{L_0 z_{pd}} \quad (15.5.2.2-2)$$

$C_v = \frac{\sqrt{L_0}}{50}$; $C_v \leq 0.2$ shall be taken;

L_0 and ν – see 1.2.2;

F_{pd} – projected area in the horizontal plane of upper deck, including any forecastle deck, in way of $x \geq +0.3L_0$, [m²];

F_{wd} – area of waterplane at draught T in way of $x \geq +0.3L_0$, [m²];

z_{pd} – vertical distance from the summer load waterline to deck line of the projected deck at F.P. [m].

The values of k_{wm} coefficients adjusted for parameter $C_a = C_{av}$ apply to loading conditions causing hogging or sagging still water bending moments. The values of coefficient k_{wm} adjusted for $C_a = C_{af}$ apply to loading conditions causing sagging only.

If $C_{af} \geq 0.5$, the adjustment of k_{wm} coefficients for $C_a = C_{av}$ parameter shall not be made.

The adjusted values of k_{wm} are as follows:

- for $C_a \leq c_1$
 k_{wm} shall be determined in accordance with paragraph 15.5.2.1 (without adjustment),
- for $C_a \geq c_2$
 $k_{wm} = 1.2$ within $-0.02L_0 \leq x \leq +0.15L_0$,
 $k_{wm} = 0.0$ for $x = -0.5L_0$ and $x = 0.5L_0$,
- for intermediate values $c_1 < C_a < c_2$, and for x co-ordinate, the values of k_{wm} coefficient shall be determined by linear interpolation;

c_1 and c_2 – the limit values of C_a :

$c_1 = 0.28$; $c_2 = 0.32$ when $C_a = C_{av}$ and

$c_1 = 0.40$; $c_2 = 0.50$ when $C_a = C_{af}$.

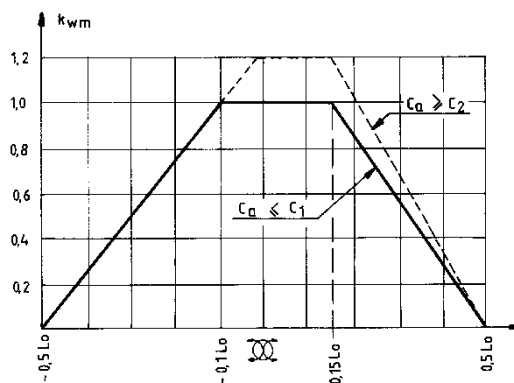

Fig. 15.5.2.2. Distribution of k_{wm} along the ship's length

15.5.3 Horizontal Wave Bending Moment

The design horizontal wave bending moment M_{wh} in each section along the ship length shall be determined in accordance with the following formula:

$$M_{wh} = 0.22L_0^{9/4} (T + 0.3B) \delta \left(1 + \cos \frac{2\pi x}{L_0} \right) \quad [\text{kNm}] \quad (15.5.3)$$

x – coordinate, see Fig. 1.2.3.1.

15.6 Extent of High Strength Steel Application

15.6.1 The vertical extent of HS steel application measured from the bottom or deck toward hull cross-section neutral axis shall not be less than that determined in accordance with the following formula:

$$z_{HS} = z_n \frac{f - k}{f} \quad [m] \quad (15.6.1)$$

k – material factor (in accordance with 2.2.1) for the members located more than z_{HS} from the deck or bottom (see Fig. 15.6.1);

f – see 13.1.2;

z_n – see 15.1.2.

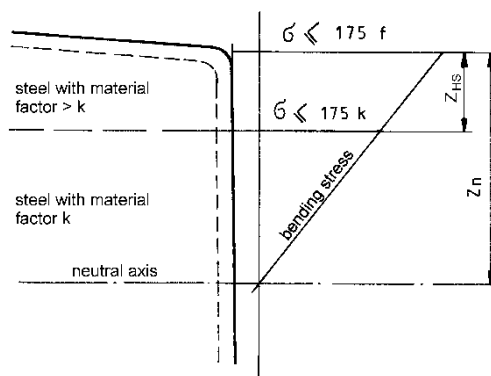

Fig. 15.6.1. Vertical extent of HS steel application

15.6.2 The longitudinal extent of HS steel application (x_{HS}) in the bottom or deck shall not be less than that shown in Fig. 15.6.2.

Fig. 15.6.2 a) shows application of HS steel members amidships (within $-0.2L_0 \leq x \leq +0.2L_0$) extended, without the change of material and scantlings, to the point where their scantlings become equal to those required at that point for members made of NS steel.

Fig. 15.6.2 b) shows the application of HS steel members also outside amidships reducing, within this area, the scantlings of longitudinal members in accordance with the requirements of the Rules. Outside the area of HS steel application, these members are extended without the change of material and scantlings, to the point where their scantlings become equal to those required at that point for members made of NS steel.

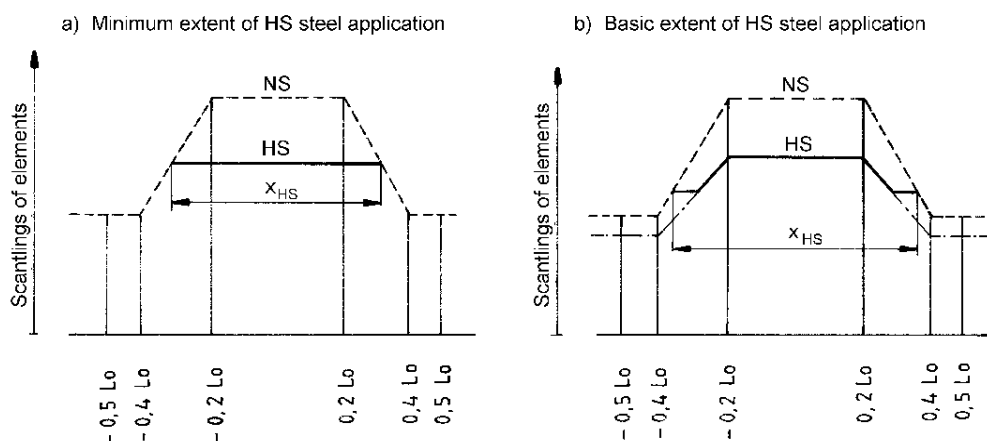

Fig. 15.6.2. Longitudinal extent of HS steel

15.7 Geometrical Data on Hull Cross-section as Built

15.7.1 Section Modulus and Moment of Inertia of Hull Section

15.7.1.1 When calculating the hull cross-section moments of inertia and section modulus, the following shall be taken into account:

- the sectional area of continuous longitudinal strength members (the effect of openings being taken into consideration in accordance with 15.7.2);
- the value of effective sectional area of longitudinal strength members between rows of hatch openings shall be multiplied by factor 0.6 or shall be determined on the basis of stress analysis conducted in a way accepted by PRS in each particular case;
- superstructures which do not form a strength deck shall not be included in the sectional area;
- deckhouses, bulwarks and non-continuous hatch side coamings shall not be included in the sectional area.

When calculating the hull section modulus, continuous longitudinal strength members may be taken into consideration if:

- the scantlings of the cross-sectional area of the members are maintained within $-0.2L_0 \leq x \leq +0.2L_0$;
- outside the above-mentioned region, the reduction of the member scantlings is gradual;
- the change of strength properties of the applied steel fulfils the requirements specified in 15.6.

In special cases, considering the ship type, hull form and loading conditions, the scantlings of strength members may be gradually reduced towards the ends of midship part of the ship ($-0.2L_0 \leq x \leq +0.2L_0$), bearing in mind the desire not to inhibit the vessel's loading flexibility.

15.7.1.2 The hull section modulus generally refers to the base plane and strength deck line at side.

For ships with continuous longitudinal hatch coamings or other continuous longitudinal strength members above the strength deck, effectively supported by longitudinal bulkheads or deep girders, the Rule section modulus shall be referred to the line above the neutral axis at the distance determined in accordance with the following formula:

$$z_t = (z_n + z_a) \left(0.9 + 0.2 \frac{y_a}{B} \right) \quad [\text{m}] \quad (15.7.1.2)$$

however not less than z_n ;

z_n – see 15.1.2;

z_a – distance from the strength deck to the member in question, [m];

y_a – horizontal distance from the ship centre plane to the member in question, [m].

y_a and z_a co-ordinates shall be so selected as to obtain the greatest value of z_t .

15.7.2 Determining Influence of Openings on Effective Cross-sectional Area of Hull

15.7.2.1 When calculating the midship section modulus, openings exceeding 2.5 m in length or 1.2 m in breadth and scallops, where scallop welding has been applied, shall be deducted from the sectional areas of continuous longitudinal members.

15.7.2.2 Smaller openings (manholes, lightening holes), as well as ineffective sections of cross-sectional area of longitudinal structural members (e.g. scallops, flow or ventilation openings, structural member ends areas, etc., see Fig. 15.7.2.2) need not be deducted when calculating the cross-sectional area of these members, provided that the sum of their breadths in one transverse section does not reduce the section modulus at deck or bottom by more than 3%. The height of these openings in longitudinals and longitudinal girders shall not exceed 25% of the web depth (75 mm for scallops), and the distance between single openings or groups of openings along the stiffener (girder) shall not be less than 10 times the height of opening. The sum of breadths of smaller

openings in one transverse section of bottom or deck, equal to $0.06(B - \Sigma b_i)$ (Σb_i – the sum of breadth of openings), may be considered as equivalent to the above reduction in section modulus.

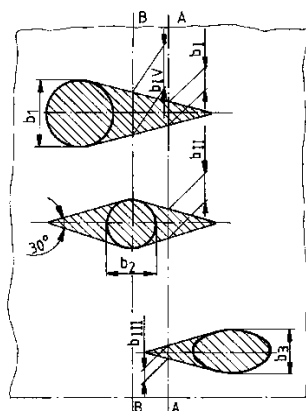

Fig. 15.7.2.2. Examples of determining the influence of openings on the effective sectional area

15.7.2.3 It is assumed that the openings which need not be deducted are arranged approximately symmetrically about ship's centre plane and that the openings do not cut any continuous longitudinal or girder included into the midship section area.

15.7.2.4 The cross-section area of openings subjected to deduction may be compensated as a whole or in part by increased plate thickness, additional longitudinal stiffeners or increase of sectional area of existing longitudinals or girders in way of the opening.

Compensation shall be extended accordingly outside the opening edge. Other compensation methods may be applied upon PRS acceptance in each particular case.

15.7.2.5 When calculating the total breadth of openings in one cross-section, the openings are assumed to have longitudinal extension as shown by the shaded areas in Fig. 15.7.2.2, inside tangents at angle 30° to each other, and symmetric about the longitudinal axis. For instance, the total design breadth of openings in section A-A is:

$$b_{A-A} = b_I + b_{II} + b_{III}, \text{ and in section B-B: } b_{B-B} = b_2 + b_{IV}.$$

15.8 Shear Strength

15.8.1 Application

The requirements of the present sub-chapter apply to ships:

- with single or double skin construction of the side shell without effective longitudinal bulkheads;
- with two or more effective longitudinal bulkheads.

The shear strength in ships with one effective longitudinal bulkhead is subject to PRS consideration in each particular case.

15.8.2 General Requirements

15.8.2.1 To check the shear strength, the following length regions and the ship's cross-sections are distinguished:

- region A_1 – between fore bulkhead in after cargo tank (after hold) and after bulkhead in fore cargo tank (fore hold);
- region B_1 – at fore bulkhead of machinery space located aft. Where the machinery space is located in the direction of midship, the section B_1 corresponds with the aft boundary of region A_1 ;

- region B_2 – at after bulkhead of forepeak. Where a deep tank is positioned between the forepeak and the forward cargo tank (fore hold), the section B_2 is at the after bulkhead of the deep tank.

15.8.2.2 The shear strength of ship's hull is considered satisfactory, provided the following requirements are fulfilled:

- the requirements concerning thickness of the ship's sides and effective longitudinal bulkheads, specified in 15.11.1 and 15.11.2, sufficient for transmission of the design shear forces. This applies to all cross-sections of ships without effective longitudinal bulkheads and to ships with two effective longitudinal bulkheads;
- the requirement, specified in 15.11.3, relating to the minimum shear strength in hull sections B_1 and B_2 at specified load conditions;
- the requirement, specified in 15.11.4, relating to the minimum sum of plating thickness of the ship's sides and effective longitudinal bulkheads. This applies to ships with two or more effective longitudinal bulkheads;
- the requirement, specified in 15.11.4, regarding the minimum thickness of effective longitudinal bulkheads. This applies to ships with two effective longitudinal bulkheads.

15.8.2.3 The thicknesses of side shell and effective longitudinal bulkheads less than those required by the present sub-chapter may be applied if the stress analysis carried out by a method approved by PRS proves those thicknesses to be satisfactory.

15.8.2.4 Where the shear stress analysis in side shell and effective longitudinal bulkheads is conducted, their thickness shall be determined taking the allowable shear stress $\tau = 110k$ [MPa].

15.9 Still Water Shear Forces

15.9.1 Loading Conditions

Still water shear forces, Q_s , shall be determined at each cross-section of the hull along the ship length for design cargo and ballast loading conditions, specified in 15.4.2. For sign conventions, see Fig. 15.4.1.1.

15.9.2 Distribution of Shear Forces along Ship's Length

The design values of still water shear forces, determined in accordance with 15.9.1, shall comply with the following requirements:

$$Q_s \geq k_s Q_{so} \quad [\text{kN}] \quad (15.9.2-1)$$

$$Q_{so} = \frac{5M_{so}}{L_0} \quad [\text{kN}] \quad (15.9.2-2)$$

M_{so} – still water bending moment – see 15.4.3 or 15.4.4, [kNm];

$k_s = 0$ for $x = -0.5L_0$ i $x = +0.5L_0$,

$k_s = 1$ for $-0.35L_0 \leq x \leq -0.2L_0$,

$k_s = 0.8$ for $-0.1L_0 \leq x \leq +0.1L_0$,

$k_s = 1$ for $+0.2L_0 \leq x \leq +0.35L_0$.

The values of k_s are varied linearly in the intermediate regions.

For ships with space arrangement giving small possibilities for variation of the cargo and ballast distribution, the value of Q_{so} may be waived as the design basis for determining the scantlings of hull structural members.

15.10 Wave Shear Forces



15.10.1 The design values of wave shear forces in particular cross-sections of the hull along the ship's length shall be determined in accordance with the following formulae:

$$Q_{wp} = 0.3k_p C_w L_0 B(\delta + 0.7) \quad [\text{kN}] \quad (15.10.1-1)$$

$$Q_{wn} = -0.3k_n C_w L_0 B(\delta + 0.7) \quad [\text{kN}] \quad (15.10.1-2)$$

Q_{wp} – positive wave shear force applied for hull cross-sections, for which the still water shear force is positive;

Q_{wn} – negative wave shear force applied for hull cross-sections, for which the still water shear force is negative.

The shear force sign shall be determined in accordance with Fig. 15.4.1.1.

$$k_p = 0 \quad \text{for } x = -0.5L_0 \text{ and } x = +0.5L_0,$$

$$k_p = \frac{1.59\delta}{\delta + 0.7} \quad \text{for } -0.3L_0 \leq x \leq -0.2L_0,$$

$$k_p = 0.7 \quad \text{for } -0.1L_0 \leq x \leq +0.1L_0,$$

$$k_p = 1 \quad \text{for } +0.2L_0 \leq x \leq +0.35L_0.$$

The values of k_p are varied linearly in the intermediate regions (see Fig. 15.10.1).

$$k_n = 0 \quad \text{for } x = -0.5L_0 \text{ and } x = +0.5L_0,$$

$$k_n = 0.92 \quad \text{for } -0.3L_0 \leq x \leq -0.2L_0,$$

$$k_n = 0.7 \quad \text{for } -0.1L_0 \leq x \leq +0.1L_0,$$

$$k_n = \frac{1.73\delta}{\delta + 0.7} \quad \text{for } +0.2L_0 \leq x \leq +0.35L_0.$$

The values of k_n are varied linearly in the intermediate regions (see Fig. 15.10.1).

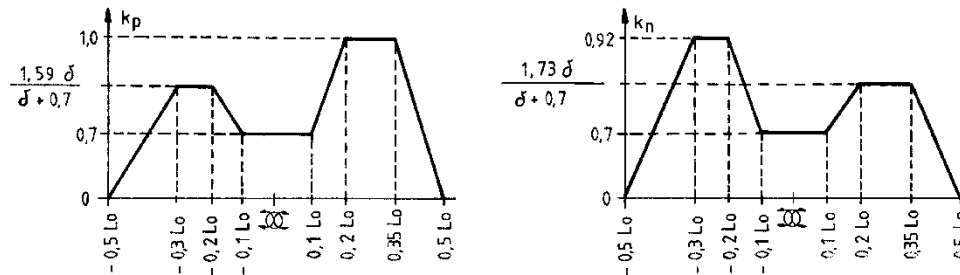

Fig. 15.10.1. Factors k_p and k_n

15.10.2 For ships with high speed or large flare in the forebody, the adjusted values of k_p and k_n shall be applied in formulae 15.10.1-1 and 15.10.1-2. The adjustment depends on the value of parameters $C_a = C_{av}$ and $C_a = C_{af}$. The adjusted values of k_p and k_n may be determined by multiplying their values, determined from 15.10.1, by the following coefficient r :

$$\text{for } C_a \leq c_1 \quad r = 1.0 \text{ within } -0.5L_0 \leq x \leq +0.5L_0;$$

$$\text{for } C_a \geq c_2 \quad r = 1.0 \text{ within } x \leq +0.1L_0,$$

$$r = 1.2 \text{ within } 0.2L_0 \leq x \leq 0.35L_0,$$

$$r = 1.0 \text{ at cross-section } x = 0.5L_0.$$

For intermediate values of $C_1 < C_a < C_2$ and x co-ordinate, the value of r shall be determined by linear interpolation.

For $C_a, C_{av}, C_{af}, c_1, c_2$ – see 15.5.2.2.

15.11 Requirements for Structures Subjected to Shear Forces

15.11.1 In ships without effective longitudinal bulkheads, the thickness of the side (sum of outer and inner side thicknesses – for double skin construction) shall not be less than that determined in accordance with the following formula:

$$t = \frac{0.5(Q_s + Q_w) \pm 0.5\Delta Q_s}{\tau} \frac{S_n}{I_n} 10^2 \quad [\text{mm}] \quad (15.11.1)$$

ΔQ_s – still water shear force correction, for direct transmission of shear forces by longitudinal structural members of the bottom to transverse bulkheads in ships with uneven distribution of load, [kN],

The value of ΔQ_s may be determined in accordance with 15.12.1 if the Q_s value has been determined from analysis of the ship loading conditions.

The value of $\Delta Q_s = 0$ if the Q_s value has been determined as $Q_s = k_s Q_{s0}$ (see 15.9.2).

$\tau = 110k$ [MPa] unless lesser value results from the buckling strength requirements.

The value of $\frac{S_n}{I_n}$ may be taken equal to $\frac{1}{90H}$ for the neutral axis of the cross-section.

For other levels, the value of S_n shall be determined for the neutral axis as the first moment of cross-sectional area of the effective longitudinal members positioned between the vertical level at which the shear stress is being calculated and the vertical extremity of effective longitudinal members, taken at the section under consideration.

15.11.2 In ships with two effective longitudinal bulkheads, the plating thickness of the ship side or longitudinal bulkhead shall not be less than:

– for side plating:

$$t = \frac{|(0.5 - k_s)(Q_s + Q_w) + \Delta Q_{sb}|}{\tau} \frac{S_n}{I_n} 10^2 \quad [\text{mm}] \quad (15.11.2-1)$$

– for bulkhead plating:

$$t = \frac{|k_s(Q_s + Q_w) + \Delta Q_{sg}|}{\tau} \frac{S_n}{I_n} 10^2 \quad [\text{mm}] \quad (15.11.2-2)$$

– k_s – participation coefficient of a given structure in shear force transmission in a considered cross-section of the ship's hull:

$$k_s = 0.34 - 0.08 \frac{A_b}{A_w}$$

A_b – mean shear area of side shell plating in the side tank under consideration, taken as the total cross-sectional area of the plating over the height H , [cm²];

A_w – mean shear area of longitudinal bulkhead or inner shell in the side tank under consideration, taken as the total cross-sectional area of the bulkhead plating between the

bottom and deck for plane bulkheads. For corrugated bulkheads, A_w shall be taken equal to 80% of the value determined for plane bulkheads, [cm²];

$\Delta Q_{sb}, \Delta Q_{sg}$ – shear force corrections for side and longitudinal bulkhead plating determined in accordance with 15.12.2.

15.11.3 In ships without effective longitudinal bulkheads or with two effective longitudinal bulkheads, the thickness of the side plating and effective longitudinal bulkheads in sections B_1 and B_2 (see 15.8.2.1) shall be not less than those determined in accordance with 15.11.1 or 15.11.2. The ship loading conditions described hereinafter, as well as those, mentioned in 15.4.2, shall be taken into account.

When determining the thickness of side plating and effective longitudinal bulkheads in way of fore bulkhead of machinery space (section B_1), the fully loaded condition, with stores at arrival, shall be taken account.

When determining the thickness of side plating and effective longitudinal bulkheads in section B_2 , the following loading conditions shall be taken into account: ballast condition with forepeak filled or fully loaded condition, with stores at arrival. The greater value of the sum of side and bulkhead thicknesses, resulting from the above-mentioned conditions, shall be taken.

If a deep tank is positioned between the forward cargo hold (cargo tank) and the forepeak, then, in a considered ballast condition, the deep tank shall be also filled.

Where forepeak and a deep tank are not intended to carry ballast when the ship is in ballast condition, the shear force in section B_2 will be subject to PRS consideration in each particular case.

15.11.4 In ships with more than two effective longitudinal bulkheads, the sum of thicknesses, measured at $z = 0.5H$, of the ship's sides and longitudinal bulkheads shall be not less than:

$$\sum t = \frac{c \sqrt[3]{L_0 B}}{k} (0.8 + 0.1n) + \sum t_k \quad [\text{mm}] \quad (15.11.4-1)$$

n – number of effective longitudinal bulkheads;

$c = 2.7$ for $n = 2$,

$c = 2.6$ for $n > 2$.

In ships with two effective longitudinal bulkheads, the thickness of each longitudinal bulkhead plating, measured at $z = 0.5H$, shall be not less than:

$$t = \frac{0.6 \sqrt[3]{L_0 B}}{k} + t_k \quad [\text{mm}] \quad (15.11.4-2)$$

Above $z = 0.5H$, the thickness of the longitudinal bulkhead plating may be gradually reduced to $0.9t$ at strength deck. The required sum of thicknesses of the ship's sides and the longitudinal bulkheads shall be maintained within the region A_1 . Beyond this region, the sum of the thicknesses of the ship's sides and longitudinal bulkheads shall be reduced linearly to the values required in 15.11.3 for B_1 and B_2 sections.

15.12 Shear Force Corrections

15.12.1 When Q_s value has been determined from analysis of ship loading conditions, then, in ships without effective longitudinal bulkheads, the shear force transmitted directly to each transverse bulkhead forming boundary of a hold may be determined in accordance with the following formula:

$$\Delta Q_s = C_p (P_h + \sum k_n P_n) - C_d T_1 \quad [\text{kN}] \quad (15.12.1-1)$$

- P_h - mass of cargo or ballast for the hold in question [t];
 P_n - mass of fuel oil or ballast in the double bottom, in tank No. n (port and starboard side), below hold in question [t];
 T_1 - ship's draught in the middle of the considered hold [m];
 C_p - cargo hold load transmission factor [kN/t];
 C_d - buoyancy transmission factor [kN/m].

The values of C_p and C_d may be taken as constants over the whole length of the hold independent of cargo filling height and draught, respectively.

The values may be determined in accordance with the following formulae:

$$C_p = \frac{9.81}{V_h} C b l h \quad [\text{kN/t}] \quad (15.12.1-2)$$

$$C_d = 10 C b l \quad [\text{kN/m}] \quad (15.12.1-3)$$

$$C = \frac{B}{2.2(B+l)} \quad (\text{for conventional designs})$$

b - breadth of the flat part of the double bottom [m];

l - length of hold [m];

h - height of hold [m];

V_h - volume of hold [m³];

$k_n = \frac{V_h a_{np}}{h a_n a_b}$, coefficient to be determined for each full tank;

a_n - horizontal cross-sectional area (port and starboard side) of tank No. n , determined at the inner bottom level [m²];

a_{np} - horizontal cross-sectional area (port and starboard side) at inner bottom level of this part of tank No. n , which is situated within the length of the considered cargo hold [m²];

a_b - sum of all areas a_{np} [m²].

The value of ΔQ_s shall be deducted from the peak-values of the conventional shear force curve in way of the loaded hold bulkheads between empty holds or the empty hold bulkheads between loaded holds (see Fig. 15.12.1).

For other loading conditions, the sign of ΔQ_s correction shall be determined in a similar manner.

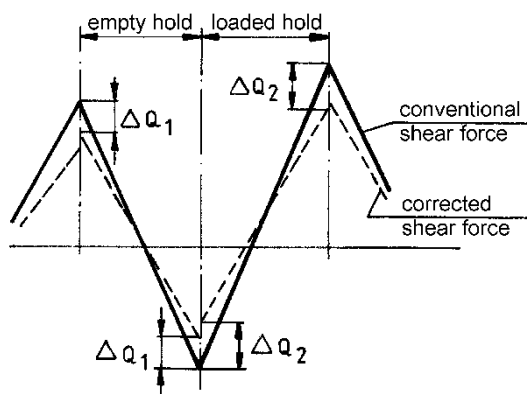

Fig. 15.12.1. Shear force correction

15.12.2 For ships with two effective longitudinal bulkheads, the values of shear force corrections ΔQ_{sg} and ΔQ_{sb} transmitted by the ship's sides and longitudinal bulkheads plating will be subject to PRS consideration in each particular case. These values may be determined with use of zone strength analysis of ship structure.

15.13 Ship Loading Control

15.13.1 General Requirements

15.13.1.1 All new ships of 65 m in length and above shall be provided with means of ship loading control in accordance with *Publication 16/P – Loading Guidance Information*, that is:

- category I ships – with loading manual and loading instrument,
- category II ships – with loading manual.

Category II ships of length less than 90 m, whose deadweight does not exceed 30% of the displacement at draught to summer load waterline are excluded from the above requirement.

15.13.1.2 Loading manual shall be approved by PRS in accordance with the conditions specified in *Publication 16/P – Loading Guidance Information*.

15.13.1.3 Loading instrument is subject to approval procedure resulting in the issue of *Program Installation Test Certificate*.

The requirements given in the following publications are applicable in the procedure: *Publication 16/P – Loading Guidance Information*, *Publication 14/P – Principles of Approval of Computer Programs*, *Publication 9/P – Requirements for Computer Based System* and *Publication 11/P – Environmental Tests of Marine Equipment*.

15.13.1.4 Loading manual and loading instrument shall be based on the final data of the ship.

15.13.1.5 In the case of modifications resulting in changes to the main data of the ship, a new approved loading manual shall be issued. In that case, if necessary and applicable, the loading instrument shall be modified accordingly, approved by PRS and suitably tested after being fitted on board the ship.

15.13.1.6 Where the hull stress monitoring system is used to control ship loading, it is subject to PRS consideration and approval in each particular case¹.

15.14 Buckling strength of hull structure subject to hull girder stresses

15.14.1 General

15.14.1.1 Requirements of subchapter 15.14 amend the requirements of chapter 13 of these rules for buckling capacity of ship hull structural elements and they are equivalent to requirements of IACS UR S35 Buckling Strength Assessment of Ship Structural Elements for structural elements subject to hull girder stresses (see p. 15.14.4).

The form and content of subchapter 15.14 text where some requirements of Chapter 8 *Buckling of IACS Common Structural Rules for Bulk Carriers and Oil Tankers* (CSR) are indicated to fulfil gives a set of requirements for buckling fully covering and amending the requirements of UR S35 for structures subject to hull girder stresses.

¹ It is recommended that the requirements of IMO MSC/Circ. 646 should be complied with.

15.14.1.2 The hull structure elements subject to the requirements of subchapter 15.14 are plates (including webs of primary supporting members), longitudinal stiffeners of plating (including stiffeners of webs of primary supporting members), primary supporting members and other structures subject to hull girder stresses.

15.14.1.3 Ship longitudinal extent where the buckling check is performed for structural elements subject to hull girder stresses is to be in accordance with requirements of p. 13.3.1.2 to p. 13.3.1.4.

15.14.2 Net Scantling Approach

15.14.2.1 Unless otherwise specified, all the scantling requirements of subchapter 15.14 are based on net scantlings obtained by removing full corrosion addition t_c from the gross thicknesses values of plating, stiffeners of plating and primary supporting members shown in approved design drawings of the ship hull structure.

15.14.2.2 Corrosion addition t_c values shall be determined applying the requirements similar to those given in CSR, Chapter 3, Section 3, p. 1.2 where values of t_{c1} and t_{c2} for both sides of the structural member and $t_{res} = 0.5$ mm are applied.

However, corrosion additions t_{c1} and t_{c2} values for dry spaces in ships, cargo holds and tanks not applied for transporting of dry bulk cargo or liquid cargo typical for tankers, and made from hull structural steel, are given in table 15.14.2.2 instead of the values in table 1 in CSR, Chapter 3, Section 3.

Table 1 in CSR, specified above, is applicable in the following requirements of subchapter 15.14 to cargo holds for bulk cargo or liquids typically transported by tankers.

Minimum value of total corrosion addition required in CSR, Chapter 3, Section 3, p. 1.2.2 are applicable.

On case –by–case basis PRS may require to apply different values of t_c from the values given above, after consideration of general plan of the ship.

Table 15.4.2.2
Corrosion addition for one side of a structural member

Compartment type		t_{c1} or t_{c2}
Ballast water tank, bilge tank, drain storage tank		1.00
Exposed to atmosphere		1.00
Exposed to seawater ⁽¹⁾		1.00
Fuel and lubrication oil tank		0.50
Fresh water tank		0.50
Void spaces		0.50
Dry spaces (inside of machinery spaces, pump rooms, steering gear space, passageways, etc.)		0.50
Container and general cargo holds, cargo spaces in Ro-Ro ships	Transverse bulkheads	0.50
	Elsewhere	1.00
Accommodation spaces		0.00
Compartments other than those mentioned above		0.50
(1) For the determination of the corrosion addition of the outer shell plating, the pipe tunnel is considered as for a ballast water tank.		

15.14.3 Slenderness requirements

15.14.3.1 Stiffeners of plating elements subject to hull girder stresses shall comply with the applicable slenderness and proportion requirements given in CSR, Chapter 8, Section 2, p. 3.1. Scantling parameters (dimensions) for popular types of the stiffeners are defined in CSR, Chapter 8, Section 2, Figure 1.

15.14.3.2 Proportions of primary supporting members web plate and flange which are subject to hull girder stresses shall comply with the applicable requirements given in CSR, Chapter 8, Section 2, p. 4.1.

Proportions of web dimensions and bending stiffness of such primary supporting members web stiffeners shall comply with requirements given in CSR, Chapter 8, Section 2, p. 4.2.

15.14.4 Stress calculation for buckling assessment

15.14.4.1 Normal stresses σ_{hg} due to general bending of ship hull applied for buckling assessment according to requirements of p.15.14.6 shall be computed as σ_r according to requirements of p. 13.3.2.7 where applied moment of inertia of the considered transverse cross-section of the hull value, I_n , is to be computed for the thickness of structural elements equal to the gross thickness shown in the design drawings decreased by half of the t_c required (see p. 15.14.2).

15.14.4.2 Shear stresses τ_{hg} due to general bending of ship hull applied for buckling assessment according to requirements of 15.14.6 shall be computed at any position along the ship applying the theory of thin-walled beams and shear force value:

$$Q = Q_s + Q_w \quad (15.14.4.2-1)$$

where:

Q_s – design value of still water shear force determined according to requirements of p. 15.9;

Q_w – design value wave force, Q_{wp} or Q_{wn} , determined according to requirements of p. 15.10.

Q_s and Q_w applied to determine Q according to formula 15.14.3.2 shall be of the same sign.

Requirements of CSR, Chapter 5, Appendix1 may be used to compute the shear flow q_i (in [N/mm]) in i -th plate of the transverse ship hull cross-section with thickness t_{i-n50} , in [mm], which is computed as the gross thickness shown in the design drawings decreased by half of the t_c required (see p. 15.4.2).

q_i is computed for shear force value $Q = 1.0$ N.

Value I_{y-n50} used in the formulae in that Appendix1 shall be understood as the value computed for the thickness t_{n50} defined above.

Shear stress τ in i -th plate, in [MPa], is computed as follows:

$$\tau_{hg} = \left| \frac{Q \cdot q_i}{t_{i-n50}} \right| \cdot 10^3 \quad (15.14.4.2-2)$$

Q value in the formula above, determined according to equation 15.14.4.2-1, should be put in [kN].

15.14.5 Stress combinations for hull girder buckling strength check

15.14.5.1 Each elementary plate (see definition of EPP in CSR, Chapter 3, Section 7, p. 2.1.1), webs of primary supporting members, longitudinal stiffeners and horizontal corrugations of

longitudinal bulkheads shall satisfy the criteria defined in p.15.14.6 with stress combinations listed in points a) and b) below.

Below σ_x means normal stress along longer side of a plate while σ_y is the normal stress along shorter side of a plate.

For σ_{hg} – see p. 15.14.4.1 and for τ_{hg} – see p. 15.14.4.2.

Value of compressive stress is considered as positive while value of tension stress is negative.

a) Longitudinal stiffening arrangement:

- Stress combination 1 with:

$$\sigma_x = \sigma_{hg}$$

$$\sigma_y = 0$$

$$\tau = 0.7\tau_{hg}$$

- Stress combination 2 with:

$$\sigma_x = 0.7\sigma_{hg}$$

$$\sigma_y = 0$$

$$\tau = \tau_{hg}$$

b) Transverse stiffening arrangement:

- Stress combination 1 with:

$$\sigma_x = 0$$

$$\sigma_y = \sigma_{hg}$$

$$\tau = 0.7\tau_{hg}$$

- Stress combination 2 with:

$$\sigma_x = 0$$

$$\sigma_y = 0.7\sigma_{hg}$$

$$\tau = \tau_{hg}$$

15.14.6 Buckling criteria

15.14.6.1 General

Any of the structural members considered in p. 15.14.6.3 to p.15.14.6.7 shall fulfill, for any form of buckling considered there, the criterion:

$$\eta_{act} \leq \eta_{all} \quad (15.14.6.1)$$

where:

$\eta_{act} = \frac{1}{\gamma_c}$ – buckling utilisation factor defined in CSR, Chapter 8, Section 1, p. 3.2, based on the applied stress, as defined in p.15.14.5;

γ_c – stress multiplier factor at failure computed as described in p. 15.14.6.3 to p. 15.14.6.7;

η_{all} – allowable value of the buckling utilization factor; $\eta_{all} = 1.0$ is applicable for applied stresses according to p. 15.14.5.

Value of η_{act} shall be computed for the net thickness of structural elements i.e. for the gross thickness decreased by value of $1.0 \cdot t_c$, where t_c is corrosion addition determined according to p. 15.14.2.2.

15.14.6.2 Definitions and basic assumptions



Equivalent Plate Panel (EPP)

Model of stiffened plating in the form of Equivalent Plate Panel (EPP) is used to assess the buckling strength.

EPP means unstiffened part of the plating between stiffeners and/or primary supporting members. For panel length and breadth – see CSR, Chapter 3, Section 7, p. 2.1.1 and Figure 16 there.

Requirements of CSR, Chapter 8, Section 3, p. 1.2 for thickness and material of EPP where it is composed of parts of different thickness or different material are to be applied.

Load Calculation Point (LCP)

Stress values or pressure value at this point are to be used in the buckling assessment required in this subchapter 15.14.

For stress values used for the buckling check of EPP, requirements of CSR, Chapter 3, Section 7, p. 2.2.2 are applicable.

For pressure and stress values used for buckling check of the stiffeners, requirements of CSR, Chapter 3, Section 7, p. 3.2.1 and p. 3.2.2 are applicable.

SP-A structural model

SP-A means that stiffened plate model is considered with Method A (see definition of Method A and Method B in CSR, Chapter 8, Sec 1, p. 3.1.3).

Standard types of stiffeners

Standard types of stiffeners are defined in CSR, Chapter 8, Section 2, Figure 1.

HP bulb profiles may be considered as equivalent built up profile according to requirements of CSR, Chapter 3, Section 7, p. 1.4.1.

15.14.6.3 Overall stiffened panel

η_{act} (see p. 15.14.6.1) shall be computed according to requirements of CSR, Chapter 8, Sec 5, p. 2.1.

γ_c shall be computed as γ_{GEB} applying stress values at LCP as required in CSR, Chapter 8, Sec 5, p. 2.2.7 for the prescriptive assessment.

15.14.6.4 Plates

η_{act} (see p. 15.14.6.1) shall be computed according to requirements of CSR, Chapter 8, Sec 5, p. 2.2 for the buckling strength of EPP applying SP-A structural model (see p.15.14.6.2) and stress values at LCP specified in p. 15.14.6.2.

Requirements of CSR, Chapter 8, Section 3, p. 1.2 apply for EPP with thickness or material that change over the width or length of the plate.

For curved plates, η_{act} shall be computed applying the plate limit state condition given in CSR, Chapter 8, Sec 5, p. 2.2.6. applying there $\sigma_{ax} = \sigma_x$ or $\sigma_{ax} = \sigma_y$ (see p. 15.14.5.1) and $\sigma_{tg} = 0$.

15.14.6.5 Stiffeners

Buckling capacity check according to p.15.14.6.5 is only required when the overall stiffened panel capacity according to p. 15.14.6.3 is satisfied.

Standard types of stiffeners usually cover possible forms of stiffeners applied (see definitions in p. 15.14.6.2).

Bulb profiles may be considered as equivalent to angle profiles, as defined in CSR, Chapter 3, Section 7, p. 1.4.1.

η_{act} (see p. 15.14.6.1) shall be computed for γ value determined according to requirements of CSR, Chapter 8, Section 5, p. 2.3 for the stress values σ_x computed according to p15.14.5.1 at LCP specified in p. 15.14.6.2 and assuming safety factor value $S = 1.0$.

Static lateral pressure shall be applied in the buckling check and its value corresponds to considered draught of ship and internal pressure of bulk or liquid cargo, or ballast. Its value is considered as constant along the stiffener.

15.14.6.6 Webs of primary supporting members

Web plates of primary supporting members without openings shall fulfill the requirements of p. 15.14.6.4 applying the normal stress σ_x or σ_y only (see p. 15.14.5.1).

For web plate fields with openings, requirements of p. 13.4.3 shall be applied.

15.14.6.7 Horizontally corrugated longitudinal bulkhead

For corrugations of horizontally corrugated longitudinal bulkheads, units composed of half flange, web and the opposite half flange (i.e. single corrugation as shown in grey in Figure 15.14.6.7) shall be considered and η_{act} (see p. 15.14.6.1) shall be computed as η according to requirements of CSR, Chapter 8, Section 5, p.3.1.1 where $\sigma_E = \sigma_{EC}$ value computed according to CSR, Chapter 8, Sec 5, p. 3.1.2 shall be applied.

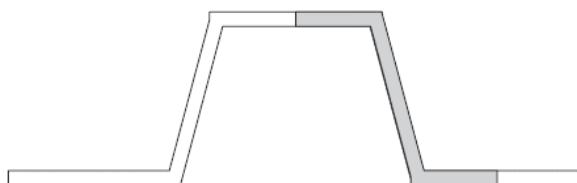

Figure 15.14.6.7 Single corrugation

16 LOCAL LOADS OF STRUCTURE

16.1 General

16.1.1 Application

16.1.1.1 The values of the design loads, determined in compliance with the below given requirements, are applicable to the calculation of scantlings of plate panels, stiffeners, simple girders, complex girder systems and supporting members of hull structure. These design values may be applied within the assumed concept of requirements only.

PRS may accept, after special consideration, values of the design loads computed directly, applying the methods described in *Publication 35/I – Wave Loads on Ships*.

16.1.1.2 The design compressive axial forces for calculating scantlings of the supporting members shall be determined in accordance with 13.7.

16.1.2 Design Load Components

When determining the design loads of structure, account has been taken of static and dynamic load components due to:

- sea pressure (see 16.2),
- pressure from liquids in tanks (see 16.3),
- pressure from dry cargoes, stores and equipment (see 16.4).

16.1.3 General Requirements

16.1.3.1 In general, pressure may act on both sides of the plating and the supporting members in question. Pressures shall be determined independently and the greater value shall be assumed as the design pressure. In special cases the difference in pressures acting from the opposite sides of the panel may be taken as the design pressure, provided both pressures always act simultaneously.

16.1.3.2 Tanks for crude oil or diesel oil shall be designed for liquids of density equal to that of sea water:

$$\rho = 1.025 \text{ t/m}^3 .$$

16.1.3.3 The structure of tanks for heavier liquids is subject to PRS consideration in each particular case. In such cases, the density applied as the basis for approval will be given in Appendix to the *Certificate of Class*.

16.1.3.4 For ships of restricted navigation, pressure components or coefficients representing in formulae the dynamical part of local loads of structure for unrestricted navigation area, may be reduced as below:

- for area II, by 10%,
- for area III, by 30%
- for Class C passenger ships, by 40%,
- for Class D passenger ships, by 50%.

Detailed provisions are given at the requirements for particular loads.

16.1.4 Definitions

b_a – the largest athwartship distance, parallel to y axis, from the load point to the tank corner at top of the tank most distant from the load point, [m];

- b_s – the tank top breadth, [m];
 b_z – distance, parallel to y axis, between tank sides or longitudinal wash bulkheads at the height of the load point in question, [m];
 g – acceleration of gravity, [m/s²], (see 1.2.2);
 h_a – vertical distance from the load point to the top of the tank or to the hatch coaming, [m]; for all high, narrow tanks, the value of h_a may be taken not greater than 15 times the smallest tank breadth (or length) measured above the load point;
 h_g – vertical distance from the load point to the bulkhead deck of passenger ships and the freeboard deck of cargo ships, [m]; (see resolution *MSC.429(98)/Rev.2* - “Revised Explanatory to the SOLAS Chapter II-1 Subdivision and Damage Stability Regulations”);
 In ships with very large distance from the summer load waterline to the top of the bulkhead, h_g may be based on flooding calculation;
 h_p – vertical distance from the load point to the top of air pipe, [m];
 h_0 – vertical distance from summer load waterline to the load point, [m];
 h_z – height of tank, [m];
 l_a – the largest longitudinal distance, parallel to x axis, from the load point to the tank corner at top of the tank most distant from the load point, [m];
 l_s – tank top length, [m];
 l_z – distance, parallel to x axis, between tight or wash transverse bulkheads at the height of the structural member in question, [m];
 $p_0 = 25$ kPa, in general;
 $p_0 = 15$ kPa – in ballast holds in dry cargo ships; the assumed value of p_0 shall not be less than p_v ;
 p_v – safety valve opening pressure, [kPa];
 T_m – minimum design draught, [m]; T_m shall be normally taken as $0.35T_s$ for dry cargo vessels and $0.02L_0 + 2$ – for tankers;
 ρ – density of liquid cargo, ballast or stores, [t/m³];
 $P(x, y, z)$ – point for which the sea pressure is determined;
 p_i – sea pressure in point P , $i = 1, \dots, 5$ [kPa].

16.2 Sea Pressures

16.2.1 General Requirements

The external sea pressure acting on the ship’s bottom, sides and the weather deck shall be determined in accordance with the formulae specified in the present sub-chapter.

16.2.2 External Pressure Acting on Ship’s Hull

16.2.2.1 The external sea pressure acting at point $P(x, y, z)$ of the ship’s side below the summer load waterline or the bottom shall be determined in accordance with the following formula:

$$p_1 = 0.5p_{ab} + 10(T_s - z) \text{ [kPa]} \quad (16.2.2.1-1)$$

$$p_{ab} = (1 + 0.036v)[0.7Z_A + k_x\theta_A + 3|y|\Phi_A] + 0.02L_0 \cdot [10 - 0.25(T_s - z)] \text{ [kPa]} \quad (16.2.2.1-2)$$

$$k_x = -4(x + 0.05L_0) \text{ for } x < -0.05L_0 \quad (16.2.2.1-3)$$

$$k_x = 5.4(x + 0.05L_0) \text{ for } x \geq -0.05L_0$$

v – ship’s speed, [knots];

Z_A, θ_A, Φ_A – see 17.3.2 and 17.3.3;



x, y, z – co-ordinates of point $P(x, y, z)$ – see Fig. 17.2.1.

16.2.2.2 The external sea pressure acting at point $P(x, y, z)$ of the ship's side at the level of the exposed deck shall be determined in accordance with the following formula:

$$p_2 = 0.5 p_{ds} \quad [\text{kPa}] \quad (16.2.2.2-1)$$

$$p_{ds} = \rho g [S_A - (z - T_S)] \quad [\text{kPa}] \quad (16.2.2.2-2)$$

$\rho = 1.025 \text{ t/m}^3$;

$[S_A - (z - T_S)] \geq 2$ shall be assumed;

S_A – see 17.3.7;

$z - T_S$ – distance from the summer load waterline to point P .

16.2.2.3 The pressure between the deck level and summer load waterline shall be determined by linear interpolation. The pressure in extreme points is determined in accordance with formulae 16.2.2.1-1 and 16.2.2.2-1.

16.2.2.4 The external sea pressure acting at point $P(x, y, z)$ of the exposed deck shall be determined in accordance with the following formula:

$$p_3 = 0.5 p_{dd} \quad [\text{kPa}] \quad (16.2.2.4-1)$$

$$p_{dd} = 0.5 \rho (g + 0.5 a_v) [S_A - (z - T_S)] \quad [\text{kPa}] \quad (16.2.2.4-2)$$

$[S_A - (z - T_S)] \geq 2$ shall be assumed;

S_A and a_v – see 17.3.7 and 17.4.1;

$\rho = 1.025 \text{ t/m}^3$.

16.2.2.5 The sea pressure acting on the ship's bottom and sides which may be deducted from the internal pressure in tanks adjacent thereto corresponds to the minimum design draught of the ship in still water. The value of the external pressure shall be determined in accordance with the following formula:

$$p = \rho g (T_m - z) \quad [\text{kPa}] \quad (16.2.2.5)$$

$p \geq 0$ shall be taken;

$\rho = 1.025 \text{ t/m}^3$;

z – co-ordinate of the considered point, [m].

16.2.3 External Pressure Acting on Superstructures

16.2.3.1 The external sea pressure acting on exposed sides and end bulkheads of a superstructure, deckhouse or engine room casing may be determined in accordance with the following formulae given in 16.2.3.2 and 16.2.3.3.

16.2.3.2 At point $P(x, y, z)$ of the exposed front bulkhead of superstructure or deckhouse

$$p_4 = 3 p_{dd} \quad [\text{kPa}] \quad (16.2.3.2)$$

$[S_A - (z - T_S)] \geq 1$ shall be assumed

p_{dd} – see 16.2.2.4.

16.2.3.3 At point $P(x, y, z)$ of exposed side and aft bulkheads of superstructures and deckhouses

$$p_5 = 0.5 p_{ds} \quad [\text{kPa}] \quad (16.2.3.3)$$

$[S_A - (z - T_S)] \geq 1$ shall be assumed

S_A – see 17.3.7;

z – co-ordinate of the considered point, [m];

p_{ds} – see 16.2.2.2.

16.2.4 Emergency Condition Pressures

16.2.4.1 The design pressure on watertight bulkhead (compartment flooded) shall be determined in accordance with the following formula:

$$p_{d_1} = \rho g h_g \quad [\text{kPa}] \quad (16.2.4.1)$$

$\rho = 1.025 \text{ t/m}^3$.

16.2.4.2 The design pressure acting on the inner bottom (double bottom flooded) shall not be less than that determined in accordance with the following formula:

$$p_{d_2} = \rho g T_S \quad [\text{kPa}] \quad (16.2.4.2)$$

$\rho = 1.025 \text{ t/m}^3$.

This pressure is also the minimum pressure considered at determining the scantlings of plate floors and side girders forming boundaries of the double bottom tanks.

16.3 Pressure of Liquids in Tanks

16.3.1 General Requirements

If the liquid cargo tanks may be either full or empty, the design pressure acting on the structures forming boundaries of these tanks shall be determined in accordance with the requirements specified in 16.3.2. The structures forming boundaries of the tanks are: inner and outer bottom, sides, bilge, decks, platforms, watertight walls (bulkheads) of tanks situated anywhere within the ship space. These structures may form common boundaries of neighbouring tanks and in that case they shall be considered separately, as a boundary of each tank.

16.3.2 Pressure of Liquid in Full Tanks

The design pressure for structures forming the boundaries of full tanks shall be taken as the greatest value of $p_6 \div p_{10}$ pressures, determined in accordance with the following formulae:

$$p_6 = (g + 0.5a_v) \rho h_a \quad [\text{kPa}] \quad (16.3.2-1)$$

$$p_7 = 0.67 \rho g h_p \quad [\text{kPa}] \quad (16.3.2-2)$$

$$p_8 = \rho g h_a + p_0 \quad [\text{kPa}] \quad (16.3.2-3)$$

$$p_9 = g \rho \left[0.67(h_a + \Phi_A l_a) - 0.12 \sqrt{h_z l_s \Phi_A} \right] \quad [\text{kPa}] \quad (16.3.2-4)$$

$$p_{10} = g \rho \left[0.67(h_a + \Phi_A b_a) - 0.12 \sqrt{h_z b_s \Phi_A} \right] \quad [\text{kPa}] \quad (16.3.2-5)$$

a_v – in accordance with 17.4.1;

Φ_A – in accordance with 17.3.3;

Θ_A – in accordance with 17.3.2.

Formulae 16.3.2-4 and 16.3.2-5 shall be applied at dimensioning the structures forming boundaries of cargo or ballast tanks, the length of which exceeds $0.15L_0$ or the maximum breadth exceeds $0.4B_S$.

Formulae 16.3.2-1, 16.3.2-4 and 16.3.2-5 shall be also used at checking the strength of the inner bottom, sides, decks (platforms), longitudinal and transverse bulkheads forming boundaries of dry cargo holds which are also intended for the carriage of ballast.

The design pressures of independent tanks (gas carriers, sulphur carriers, asphalt carriers, etc.) will be subject to PRS consideration in each particular case.

16.3.3 Pressure of Liquid in Partly Filled Tanks

16.3.3.1 The pressure in tanks which may be filled between 20% and 90% of the tank height (tank parameters $l_z \leq 0.13L_0$ and $b_z \leq 0.56B$) shall be taken as the greater of the values determined for full tanks, in accordance with 16.3.2, and the values not lesser than those determined in accordance with the formulae, respectively:

– for structural members located within $0.25l_z$ from the transverse end bulkheads of the tank:

$$p_{11} = \rho(4 - 0.005L_0)l_z \quad [\text{kPa}] \quad (16.3.3.1-1)$$

– for structural members located within $0.25b_z$ from tank longitudinal sides:

$$p_{12} = \rho(3 - 0.01B)b_z \quad [\text{kPa}]. \quad (16.3.3.1-2)$$

For tanks with parameters $l_z > 0.13L_0$ or $b_z > 0.56B_S$, the values of pressures p_{11} or p_{12} will be subject to PRS consideration in each particular case. In respect of ships of $50 \text{ m} \leq L_0 < 100 \text{ m}$, pressure p_{11} will be subject to PRS consideration in each particular case if $l_z > 0.2L_0$.

16.3.3.2 The design pressure on girder webs in cargo and ballast tanks shall not be less than 20 kPa.

16.3.3.3 The design pressure on transverse and longitudinal wash bulkheads shall be not less than that determined from formulae 16.3.3.1-1 and 16.3.3.1-2.

16.3.3.4 Where appropriate, with respect to a given region, the structures of the ship's sides, decks, longitudinal and transverse bulkheads forming boundaries of tanks shall be checked for pressure p_{11} in ships of $L_0 \geq 50 \text{ m}$ and for pressures p_{11} and p_{12} in ships of $L_0 \geq 100 \text{ m}$.

16.4 Cargo Loads

16.4.1 General Cargo Loads

16.4.1.1 The pressure acting on cargo decks and bottom in cargo holds from general cargo or equipment shall be determined in accordance with the following formula:

$$p_{13} = (g + 0.5a_v)q \quad [\text{kPa}] \quad (16.4.1.1)$$

a_v – according to 17.4.1;

$q = \rho h$ – the mass of cargo or equipment per 1 m^2 of the loaded area, [t];

ρ – density of cargo loading on the structure in question, [t/m³].

When there are no other indications, $\rho = 0.7 \text{ t/m}^3$ shall be taken for general cargo. Where, in result of the application of $\rho = 0.7 \text{ t/m}^3$ for all cargo areas designed for the carriage of general cargoes, the ship's deadweight is exceeded, the assumed value of ρ may be reduced subject to PRS acceptance in each particular case. If the mass of deck exceeds 10% of the cargo mass assumed for this deck, then, when determining the value q for this deck, account shall be taken of the mass of deck and the mass of cargo carried on the deck.

h – height of cargo tier loading acting on a given structure, [m].

For the structures of the cargo hold bottom, as well as the structures of the sheltered decks designed for the carriage of general cargo, the height h shall be measured vertically from the load point to the deck above; in way of hatchways – to the top of the coaming.

For sheltered decks not intended for the carriage of cargo, the following values of q may be taken:
 $q = 1.6 \text{ t/m}^2$ for platform decks in machinery space (lesser values may be applied if they result from the weight of the ship's equipment to be stowed on the platform deck),
 $q = 0.35 \text{ t/m}^2$ for accommodation decks.

When direct zone strength analysis has been made for accommodation decks, including deck own mass, the value of q may be reduced, but shall be taken not less than $q_{\min} = 0.25 \text{ t/m}^2$.

16.4.1.2 Where the weather deck is designed to carry deck cargo, the design pressure for this deck shall be taken equal to $p = p_2$ or $p = p_{13}$, whichever is the greater (for definitions of p_2 and p_{13} – see 16.2.2.2 and 16.4.1.1).

If the design stowage height on the weather deck is smaller than 2.3 m, summation of loads from cargo and partly from sea may be required.

For the weather cargo decks, the minimum value of q , [t/m^2], shall be as follows:

$q = 1.0$ for $L_0 \leq 100 \text{ m}$ – in general,
 $q = 1.3$ for $L_0 \geq 150 \text{ m}$ – for superstructure deck,
 $q = 1.75$ for $L_0 \geq 150 \text{ m}$ – for freeboard deck.

For ships of length $100 \text{ m} < L_0 < 150 \text{ m}$, the value of q_{\min} shall be determined by linear interpolation.

16.4.1.3 In ships of restricted service, pressures $p = p_{13}$, determined in accordance with 16.4.1.1 for sheltered cargo decks, platform decks in machinery space, accommodation decks, as well as the weather cargo deck, may be reduced in accordance with 16.1.3.4.

16.4.1.4 Where transverse forces from deck cargo are required (e.g. for dimensioning the transverse support of hatch covers), they may be determined in the same way as the forces for heavy units, i.e. in accordance with formula 16.4.4.

16.4.2 Bulk Cargo Loads

16.4.2.1 The pressure from bulk cargoes on sloping and vertical sides and bulkheads shall be determined in accordance with the following formula:

$$p_{14} = \rho h_a (g + 0.5a_v) K \quad [\text{kPa}] \quad (16.4.2.1)$$

a_v – in accordance with sub-chapter 17.4.1;

$K = \sin^2 \alpha \text{tg}^2(45^\circ - 0.5 \gamma) + \cos^2 \alpha$;

α – angle between panel in question and the horizontal plane, [degrees];

γ – angle of repose of cargo, [degrees]. It shall be taken as follows:

$\gamma \leq 20^\circ$ for light bulk cargo (coal, grain),



$\gamma \leq 25^\circ$ for cement ($\rho = 1.35 \text{ t/m}^3$),
 $\gamma \leq 35^\circ$ for heavy bulk cargo (ore);
 ρ – cargo density in accordance with 16.4.2.2 or 16.4.3, [t/m^3].

In ships of restricted service, the value of pressure p_{14} , determined in accordance with formula 16.4.2.1, may be reduced in accordance with indications given in 16.1.3.4.

16.4.2.2 The design pressure in holds for bulk cargo of uncertain characteristics shall be determined for the standard cargo density:

$$\rho = \frac{M_c}{V_h} \text{ [t/m}^3\text{]} \quad (16.4.2.2)$$

M_c – the greatest total weight of cargo in the ship [t];
 V_h – total volume of cargo holds [m^3];
 $\rho > 0.7 \text{ t/m}^3$ shall be taken.

16.4.3 Heavy Bulk Cargo Loads

16.4.3.1 The design pressure for holds intended for ore or other heavy bulk cargoes shall be determined taking cargo density corresponding to the greatest expected mass of cargo in the hold in question, for ship fully loaded:

$$\rho = \frac{M_h}{V_h} \text{ [t/m}^3\text{]} \quad (16.4.3.1)$$

M_h – allowable load in the hold in question [t];
 V_h – total cargo hold volume, including the hatchway in question [m^3].

16.4.3.2 For ships with additional mark **HC/ALT** or **HC/E** in the symbol of class, cargo density for any hold shall be increased by 25% of ρ value as given in 16.4.2.2.

16.4.4 Heavy Units Loads

The components of forces acting on supporting structures and securing system for heavy units of cargo, equipment and stores shall be determined in accordance with the following formulae:

– vertical force alone or in combination with longitudinal force, determined in accordance with formula 16.4.4-4:

$$P_v = (g + 0.5a_v) M \text{ [kN]} \quad (16.4.4-1)$$

– vertical force in combination with transverse force, determined in accordance with formula 16.4.4-3:

$$P_{vt} = gM \text{ [kN]} \quad (16.4.4-2)$$

– transverse force in combination with vertical force, determined in accordance with formula 16.4.4-2:

$$P_t = 0.67a_T M \text{ [kN]} \quad (16.4.4-3)$$

– longitudinal force in combination with vertical force, determined in accordance with formula 16.4.4-1:

$$P_l = 0.67a_L M \text{ [kN]} \quad (16.4.4-4)$$

M – mass of unit in question, [t];
 a_v – vertical acceleration, [m/s^2], determined in accordance with 17.4.1;

a_T - transverse acceleration, [m/s²], determined in accordance with 17.4.2;
 a_L - longitudinal acceleration, [m/s²], determined in accordance with 17.4.3.

17 SHIP MOTIONS

17.1 General

17.1.1 The present Chapter gives formulae for determining motions (displacements, velocities and accelerations) of ships in sea-going conditions during their normal service.

PRS may accept, after special consideration, values of the motions computed directly, applying the method described in *Publication 35/I – Wave Loads on Ships*.

17.1.2 The ship motions determined in the present Chapter are the values for which probability of exceeding is 10^{-8} .

17.1.3 For ships of restricted service, the motions may be reduced by:

- by 10% for service area **II**;
- by 30% for service area **III**;
- by 40% for service area corresponding to mark Class C;
- by 50% for service area corresponding to mark Class D.

In justified cases, PRS may determine other reduction of ship motions.

17.2 Definitions

17.2.1 Co-Ordinate System

The co-ordinate system, as well as names of various ship motions, assumed in this Chapter, are defined in Fig. 17.2.1.

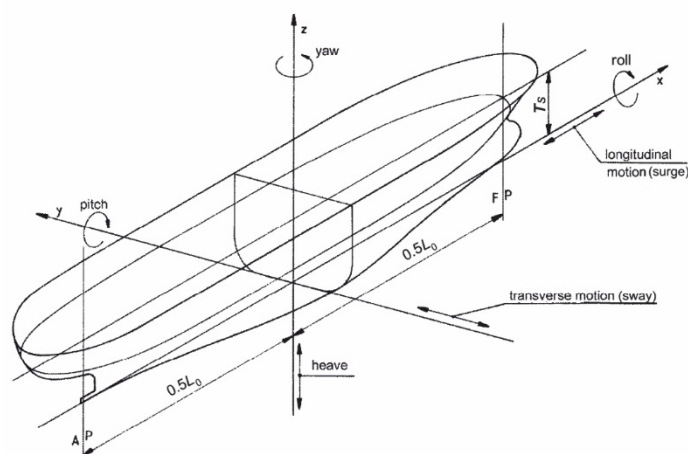

Fig. 17.2.1. Ship motions

17.2.2 Wave Coefficient

The wave coefficient C_w , which is the basic parameter for determining wave induced hull loads and ship motions, shall be determined in accordance with the following formula:

$$C_w = 0.0856L_0 \quad \text{for } L_0 < 90 \text{ m,}$$

$$C_w = 10.75 - \left(\frac{300 - L_0}{100} \right)^{3/2} \quad \text{for } 90 \text{ m} \leq L_0 < 300 \text{ m,} \quad (17.2.2)$$

$$C_w = 10.75 \quad \text{for } 300 \text{ m} \leq L_0 \leq 350 \text{ m,}$$

$$C_w = 10.75 - \left(\frac{L_0 - 350}{150} \right)^{3/2} \quad \text{for } L_0 > 350 \text{ m.}$$

17.3 Amplitudes of Ship Motions

17.3.1 Heave Amplitude

The heave amplitude may be determined in accordance with the following formula:

$$Z_A = 12 - 0.1T_S \text{ [m]} \quad (17.3.1)$$

T_S – see sub-chapter 1.2.2.

17.3.2 Pitch Amplitude

The pitch amplitude may be determined in accordance with the following formula:

$$\theta_A = 4 \left(1 - 4.5 \frac{T_S}{L_0} \right) \frac{C_w}{L_0} \text{ [rad]} \quad (17.3.2)$$

17.3.3 Roll Amplitude

The roll amplitude may be determined in accordance with the following formula:

$$\Phi_A = 35 \frac{T_S}{B_S^2 + 50} \text{ [rad]} \quad (17.3.3)$$

17.3.4 Surge Amplitude

The surge amplitude may be determined in accordance with the following formula:

$$X_A = 8 \frac{1 - 0.03T_S}{1 - 0.036v} \text{ [m]} \quad (17.3.4)$$

v – ship speed, [knots].

17.3.5 Sway Amplitude

The sway amplitude may be determined in accordance with the following formula:

$$Y_A = 12 - 0.25T_S \text{ [m]}. \quad (17.3.5)$$

17.3.6 Yaw Amplitude

The yaw amplitude may be determined in accordance with the following formula:

$$\Psi_A = 0.25 \left(1 - 0.008 \frac{L_0 T_S}{B_S} \right) \text{ [rad]}. \quad (17.3.6)$$

17.3.7 Relative Motion Amplitude

Motion amplitude of ship's point $P(x, y, z)$ in relation to the wave surface may be determined in accordance with the following formula:

$$S_A = \sqrt{(0.3Z_A)^2 + \left[(x + 0.05L_0)\theta_A \right]^2 + [0.8y\Phi_A]^2} \text{ [m]} \quad (17.3.7)$$

Z_A, θ_A, Φ_A – see paragraphs 17.3.1, 17.3.2 and 17.3.3;

x, y – co-ordinates of P point – see Fig. 17.2.1.

17.4 Resultant Acceleration Amplitudes

17.4.1 Resultant Vertical Acceleration

The resultant linear acceleration of the ship's point P along the vertical axis (taking no account of gravity acceleration) shall be determined in accordance with the following formula:

$$a_v = (1 + 0.036v)^2 \frac{25}{L_0} \sqrt{Z_A^2 + [1.6(x + 0.05L_0)\Theta_A]^2 + [0.5y\Phi_A]^2} \quad [\text{m/s}^2] \quad (17.4.1)$$

v – ship speed, [knots];

Z_A, Θ_A, Φ_A – see paragraphs 17.3.1, 17.3.2 and 17.3.3;

x, y – co-ordinates of P point – see Fig. 17.2.1.

17.4.2 Resultant Transverse Acceleration

The resultant linear acceleration of the ship's point P along the transverse axis (taking into account gravity acceleration) shall be determined in accordance with the following formula:

$$a_T = (1 + 0.036v)^2 \frac{25}{L_0} \sqrt{(0.8Y_A)^2 + [(x + 0.05L_0)\Psi_A]^2 + [(z - T_S)\Phi_A]^2} \quad [\text{m/s}^2] \quad (17.4.2)$$

v – ship speed, [knots];

Θ_A, Y_A, Ψ_A – see paragraphs 17.3.2, 17.3.5 and 17.3.6;

x, z – co-ordinates of P point – see Fig. 17.2.1.

17.4.3 Resultant Longitudinal Acceleration

The resultant linear acceleration of the ship's point P along the longitudinal axis (taking into account gravity acceleration) shall be determined in accordance with the following formula:

$$a_L = (1 + 0.036v)^2 \frac{25}{L_0} \sqrt{(0.2X_A)^2 + [0.5y\Psi_A]^2 + [2(z - T_S)\Theta_A]^2} \quad [\text{m/s}^2] \quad (17.4.3)$$

v – ship speed, [knots];

Θ_A, X_A, Ψ_A – see paragraphs 17.3.2, 17.3.4 and 17.3.6;

y, z – co-ordinates of P point – see Fig. 17.2.1.

17.4.4 Resultant Acceleration in Any Direction

The resultant linear acceleration of the ship's point P in any direction may be determined from ellipsoid (Fig. 17.4.4) with principal axes ($a_v + g$), a_T and a_L .

a_v, a_T and a_L – see paragraphs 17.4.1, 17.4.2 and 17.4.3.

$P(x, y, z)$ – point for which the accelerations are determined.

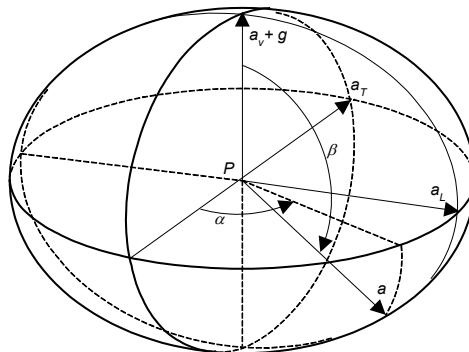

Fig. 17.4.4. Determining acceleration a of the ship's point P in any direction

18 CONTAINER CARRIERS

18.1 General

18.1.1 Application

The requirements specified in the present Chapter apply to ships intended for the carriage of containers at fixed positions in holds equipped with cell guides or on deck, having double bottom and double sides or single sides, together with the effective case structure at the upper deck and large hatch openings.

Where other structural arrangement is applied, the relevant requirements specified in the present Chapter shall be complied with within the scope agreed with PRS.

The requirements specified below shall be regarded as supplementary to the basic requirements specified in Chapters 1÷13 (except 13.3), 14, 15.13, 16, 17.

18.1.2 Classification

Ships complying with the relevant requirements of the present Chapter may be affixed with additional mark in the symbol of class:

CONTAINER SHIP – ships exclusively intended for the carriage of containers and arranged with cell guides in holds,

ACC – ships primarily intended for the carriage of other cargo but arranged for the carriage of containers.

For ships which have been affixed with one of the above-mentioned additional marks in the symbol of class, a statement of the maximum number of twenty foot equivalent units (TEU) that may be carried on board, determined by the designer, will be entered into the ship's *Certificate of Class*.

18.1.3 General Requirements

Structural arrangement of ships intended for the carriage of other cargo, but adapted for the carriage of containers, may result from the main designation of the vessel.

It is assumed that in each case the containers are supported and secured to the hull structure. Stowage arrangement of containers, guide cells in container holds and fixed equipment for securing the containers shall comply with the requirements specified in Chapter 15, *Part III – Hull Equipment*.

Equipment for securing the containers shall comply with the below-specified requirements if it is an integral part of the hull structure.

18.1.4 Documentation

Technical documentation, within the scope specified in 1.4.2, shall be submitted for consideration and approval.

18.2 Materials and Welding

18.2.1 Fixed equipment (permanently attached to the hull structure) for securing the containers shall be made of steel complying with the requirements specified in Chapter 2. The application of other steel grades or materials is subject to PRS consideration in each particular case.

18.2.2 Castings forming the fixed equipment for securing the containers, connected to the hull structure, shall comply with the requirements specified in *Part IX – Materials and Welding*.

18.2.3 Welding of structural members of fixed equipment for securing the containers to the hull structure shall comply with the requirements specified in Chapter 4.

18.2.4 YP36, YP40 and YP47 refers to the minimum specified yield strength of steel defined in Part IX; 355, 390 and 460 N/mm² respectively. Material factor, *k*, of YP36 is to be taken as 1.39, YP40 – as 1.47 and YP47 – as 1.61. UR S33: The HT factor (Material factor of high tensile steel, K) of YP47 steel for the assessment of hull girder strength is to be taken as 1.61

In the case that YP47 steel plates are used for longitudinal structural members in the upper deck region such as hatch side coaming and hatch coaming top, their attached longitudinals, the grade of YP47 steel plates shall be EH47. Material factor, *k*, for this steel shall be taken as 1.61.

18.2.5 Brittle crack arrest steel is defined in 2.1.2 of UR W31. Only for the scope of this Chapter the definition in UR W31 2.1.2 also applies to YP36 and YP40 steels.

18.3 Structure

18.3.1 Maximum continuity of structure shall be provided, avoiding abrupt changes of shape and dimensions of structural members, in order to reduce the stresses to the minimum.

18.3.2 In ships with the length $L_0 \geq 100$ m, it is recommended that longitudinal framing should be applied for bottom, strength deck and the upper parts of sides.

18.3.3 Double bottom longitudinal girders shall, as a rule, be arranged in line with container sockets on the inner bottom.

Double bottom plate floors and web frames shall be coplanar.

18.3.4 It is recommended that case structures transverse in relation to the ship's centre plane above and under transverse bulkheads should be applied to improve the hull torsional rigidity.

It is also recommended that intermediate supports of double bottom between transverse bulkheads should be applied in the form of case structures specified above or in the form of partitions.

18.3.5 Side structure in way of steps of the inner skin, where the arrangement of containers is changed is subject to PRS consideration in each particular case.

18.3.6 The hull structure under container corners shall be adequately reinforced.

18.3.7 The structure in way of hatch corners shall comply with the requirements specified in *Publication 24/P – Strength Analysis of Container Ship Hull Structure*.

18.3.8 For longitudinal structure members made of YP36, YP40 and YP47 steel plates with thickness of over 50 mm and not greater than 100 mm, appropriate measures for prevention of brittle crack propagation shall be taken. These measures consist in:

- non-destructive testing (NDT) during ship construction (acc. to requirements of 18.6.5);
- periodic non-destructive testing (NDT) after ship delivery (acc. to requirements of 18.6.5);
- brittle crack arrest design (acc. to requirements of 18.6.3 and 18.6.5).

Equivalent measures for structure members made of YP36, YP40 and YP47 steel plates with thickness exceeding 100 mm shall be specially considered by PRS.

18.4 Hull Strength Analysis

18.4.1 Calculation of longitudinal strength of the ship shall be performed in accordance with *Publication 114/P – Longitudinal Strength Standard for Container Ships*. Additionally calculation of general strength of the ship shall be made taking into account the effect of hull torsion. It shall also be checked if the hull torsional stiffness is sufficient. The hull torsion calculation methods and criteria to be complied with are specified in *Publication 24/P – Strength Analysis of Container Ship Hull Structure*. Buckling control of structural elements shall be performed in accordance with the requirements specified in *Publication 114/P – Longitudinal Strength Standard for Container Ships*.

18.4.2 Global Analysis shall be performed for ships of length 290 m or above. The Global Analysis is a finite element analysis using full ship model, for assessing the structural strength of global hull girder structure, cross deck structure and hatch corner radii. Hull girder loads (including torsional effects) shall be considered. The following methods may be used for Global Analysis:

Method 1: Analysis where hull girder loads only (vertical bending moments and torsional moment) are directly applied to the full ship finite element model;

Method 2: Analysis where direct loads transferred from direct load analysis are applied to the full ship finite element model.

18.4.3 Cargo Hold Analysis shall be performed for ships of length 150 m or above. The Cargo Hold Analysis is a finite element analysis for assessing the structural strength of the cargo hold primary structural members in the midship region.

Primary structural members are members of girder or stringer type envelope and cargo hold boundaries, such as:

- double bottom structure (bottom plate, inner bottom plate, girders, floors);
- double side structure (shell plating, inner hull, stringers and web frames);
- bulkhead structure;
- deck and cross deck structure.

Method of strength assessment shall be according to requirements specified in 14.6.

18.5 Design Loads, Loading Conditions

18.5.1 Global Analysis

The ship is considered sailing in the North Atlantic for yielding and buckling assessments. The vertical wave bending moments shall be in line with *Publication 114/P – Longitudinal Strength Standard for Container Ships*.

The torsional moment shall be calculated according to requirements contained *Publication 24/P – Strength Analysis of Container Ship Hull Structure*.

Wave conditions presumed to lead to the most severe load condition due to vertical bending moment, horizontal bending moment and torsional moment shall be considered (see *Publication 24/P – Strength Analysis of Container Ship Hull Structure*). Load components to be considered in Global Analysis are specified in Table 18.5.1. The corresponding local loads shall be taken in accordance with chapter 16.

Loading conditions shall be considered in accordance with *Publication 114/P* and *Loading Manual*.

Table 18.5.1
Load Components to be considered in Global Analysis

	Static load	Dynamic load
Method 1	<ul style="list-style-type: none"> – still water vertical bending moment – still water torsional moment 	<ul style="list-style-type: none"> – wave-induced vertical bending moment – wave-induced horizontal bending moment – wave-induced torsional moment
Method 2	<ul style="list-style-type: none"> – static sea pressure – static container loads – static loads for ballast and fuel oil – self-weight of hull structure 	<ul style="list-style-type: none"> – wave-induced sea pressure – dynamic loads for hull structure, containers, ballast and fuel oil

18.5.2 Cargo Hold Analysis

In Cargo Hold Analysis the following wave conditions shall be considered:

- head sea condition yielding the maximum hogging and sagging vertical moments;
- beam sea condition yielding the maximum roll motion. This condition may be disregarded for some loading conditions defined in Table 18.5.2-2 where PRS deems it not necessary.

Hull girder loads shall be in accordance with *Publication 114/P*. Local loads shall be taken in accordance with chapter 16. Container loads shall be considered according to requirements of 18.5.3 ÷ 18.5.6. Loads components to be considered in Cargo Hold Analysis are specified in Table 18.5.2-1.

The minimum set of loading conditions is specified in Table 18.5.2-2.

In addition, loading condition from *Loading Manual* shall be considered where PRS deems it necessary.

Table 18.5.2-1
Load components to be considered in Cargo Hold Analysis

	Static load	Dynamic load
Hull girder loads	<ul style="list-style-type: none"> – still water vertical bending moment 	<ul style="list-style-type: none"> – wave-induced vertical bending moment
Local loads	<ul style="list-style-type: none"> – static sea pressure – static container loads – static loads for ballast and fuel oil⁽¹⁾ – self-weight of hull structure 	<ul style="list-style-type: none"> – wave-induced sea pressure – dynamic loads for hull structure, containers, ballast and fuel oil

(1) For the minimum set of loading conditions specified in Table 18.5.2-2, all ballast and fuel oil tanks in way of the cargo hold model shall be empty. If additional loading conditions other than those given in Table 18.5.2-2 are considered, ballast and fuel oil loads may be taken into consideration at the discretion of PRS in each particular case.

Table 18.5.2-2
Minimum set of loading conditions for Cargo Hold Analysis

Loading condition	Draught	Container weight	Ballast and fuel oil tanks	Still water hull girder moment
Full load condition	Scantling draught	Heavy cargo weight ⁽¹⁾ (40' containers)	Empty	Permissible hogging
Full load condition	Scantling draught	Light cargo weight ⁽²⁾ (40' containers)	Empty	Permissible hogging
Full load condition	Reduced Draught ⁽³⁾	Heavy cargo weight ⁽¹⁾ (20' containers)	Empty	Permissible sagging (minimum hogging)

One bay empty condition ⁽⁴⁾	Scantling draught	Heavy cargo weight ⁽¹⁾ (40' containers)	Empty	Permissible hogging
<p>(1) Heavy cargo weight of a container unit shall be calculated as the permissible stacking weight divided by the maximum number of tiers planned.</p> <p>(2) Light cargo weight corresponds to the expected cargo weight when light cargo is loaded in the considered holds</p> <ul style="list-style-type: none"> – Light cargo weight of a container unit in hold shall not be taken more than 55% of its related heavy cargo weight [see (1) above]. – Light cargo weight of a container unit on the deck shall not be taken more than 90% of its related heavy cargo weight [see (1) above] or 17 metric tons, whichever is the lesser. <p>(3) Reduced draught corresponding to the expected draught amidships when heavy cargo is loaded in the considered holds while lighter cargo is loaded in other holds. Reduced draught shall not be taken more than 90% of scantling draught.</p> <p>(4) For one bay empty condition, if the cargo hold consist of two or more bays, then each bay shall be considered entirely empty in hold and on deck (other bays full) in turn as separate load cases.</p>				

18.5.3 Fatigue assessment on the longitudinal structural members is to be performed in accordance with *Publication 45/P – Fatigue Strength Analysis of Steel Hull Structure*.

18.5.4 Special consideration is to be paid to the construction details where extremely thick steel are applied as structural members such as connections between outfitting and hull structures.

18.5.5 Loads resulting from securing and supporting the containers shall be determined for the most severe realistic loading condition, including the dynamic loads assumed in accordance with the requirements specified in 16.4.4.

18.5.6 When determining the static loads, the static conditions which give the largest support forces, lashing forces and the largest internal forces in the container structure (e.g. in a container block stack) shall be taken into account. The assumed mass of individual containers shall be such that the most severe realistic load condition is obtained.

Unless otherwise specified, the maximum mass of containers shall be taken as follows:

- 20' container: 24.00 t,
- 40' container: 30.48 t.

18.5.7 When determining dynamic loads from containers (inertial forces), possible combinations of vertical, transverse and longitudinal loads shall be taken into account in accordance with the requirements specified in 16.4.4.

It may be assumed that transverse and longitudinal loads do not act simultaneously. All containers in a stack or a group of stacks shall be considered as one mass assuming that they are subjected to the acceleration of gravity in combination with a uniform vertical acceleration.

Containers, the side walls of which will be exposed to wind, shall be considered for a wind force, which may be taken as follows:

$$P_W = 17.5 \text{ kN} \quad \text{for 20' containers,}$$

$$P_W = 35.0 \text{ kN} \quad \text{for 40' containers.}$$

Horizontal dynamic loads shall be taken into account in combination with wind force P_W .

18.5.8 Response of supports (forces acting on the hull structure) shall be determined assuming the total system of securing arrangements and considering, where necessary, flexibility of securing members and container sides, as well as possible effects of clearances between various connections. The calculation method is specified in Chapter 15, *Part III – Hull Equipment* and in *Publication 32/P – The Requirements for the Stowage and Securing of Cargo on Sea-Going Ships*.

18.6 Brittle Crack Arrest Design

18.6.1 General

18.6.1.1 The brittle crack arrest steel method detailed in Chapter 18.6 may be used when the measures specified in Table 18.6.5 in items 3, 4 and 5 and those below the table are applied and the steel grade material of the upper deck (structure members such as upper deck plating, hatch side coaming plating, including top plating and longitudinals) is not higher than YP40. Otherwise other means for preventing the crack initiation and propagation shall be agreed with PRS.

18.6.1.2 Measures for prevention of brittle crack propagation, shall be taken within the cargo hold region.

18.6.1.3 The measures given in sub-chapter 18.6 generally apply to the block-to-block butt joints but it should be noted that cracks can initiate and propagate away from such joints. Therefore appropriate measures should also be considered for the cases specified in 18.6.2.3.

18.6.1.4 Brittle crack arrest steels are defined in *Part IX* of the *Rules*.

18.6.2 Functional requirements of brittle crack arrest design

18.6.2.1 The purpose of the brittle crack arrest design is to arrest propagation of a crack at a proper position and to prevent large scale fracture of the hull girder.

18.6.2.2 The locations of most concern for brittle crack initiation and propagation are the block to-block butt weld joints either on hatch side coaming or on upper deck plating. Other locations in block fabrication where joints are aligned may also present higher opportunity for crack initiation and propagation along butt weld joints.

18.6.2.3 Both of the following cases shall be considered:

- .1 where the brittle crack runs straight along the butt joint, and
- .2 where the brittle crack initiates in the butt joint but deviates away from the weld and into plate, or where the brittle crack initiates from any other weld (see 18.6.2.4) and propagates into the plate.

18.6.2.4 “Other weld” includes the following (refer to Fig. 18.6.2.4)

- .1 Fillet welds where hatch side coaming plating, including top plating, meet longitudinals;
- .2 Fillet welds where hatch side coaming plating, including top plating and longitudinals, meet attachments. (e.g., fillet welds where hatch side top plating meet hatch cover pad plating);
- .3 Fillet welds where hatch side coaming top plating meet hatch side coaming plating;
- .4 Fillet welds where hatch side coaming plating meet upper deck plating;
- .5 Fillet welds where upper deck plating meet inner hull/bulkheads;
- .6 Fillet welds where upper deck plating meet longitudinal; and
- .7 Fillet welds where sheer strakes meet upper deck plating.

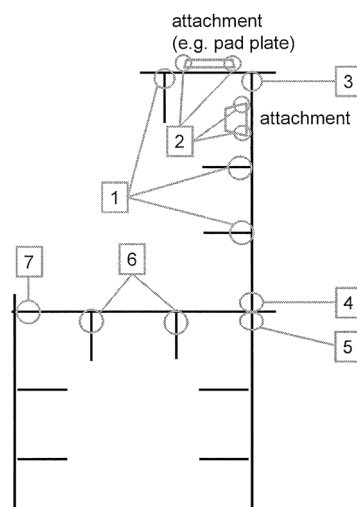

Fig. 18.6.2.4 Other weld areas

18.6.3 Variants of Design

The following methods are considered to be acceptable examples of brittle crack arrest-design. The detail design arrangements shall be submitted for approval by PRS. Other concept designs may be considered and accepted for review by PRS.

- .1 For cases as in 18.6.2.3.1:
 - a) Where the block to block butt welds of the hatch side coaming and those of the upper deck are shifted, this shift shall be greater than or equal to 300 mm. Brittle crack arrest steel shall be provided for the hatch side coaming plating.
 - b) Where crack arrest holes are provided in way of the block-to-block butt welds at the region where hatch side coaming weld meets the deck weld, the fatigue strength of the lower end of the butt weld shall be assessed. Additional countermeasures shall be taken for the possibility that a running brittle crack may deviate from the weld line into upper deck or hatch side coaming. These countermeasures shall include the application of brittle crack arrest steel in hatch side coaming plating.
 - c) Where Arrest Insert Plates of brittle crack arrest steel or Weld Metal Inserts with high crack arrest toughness properties are provided in way of the block-to-block butt welds at the region where hatch side coaming weld meets the deck weld, additional countermeasures shall be taken for the possibility that a running brittle crack may deviate from the weld line into upper deck or hatch side coaming. These countermeasures shall include the application of brittle crack arrest steel in hatch side coamings plating.
- .2 For cases as in 18.6.2.3.2: Brittle crack arresting steel shall be used for the upper deck plating along the cargo hold region in a way suitable to arrest a brittle crack initiating from the coaming and propagating into the structure below.
- .3 The application of enhanced NDT, particularly time of flight diffraction (TOFD) technique using stricter defect acceptance in lieu of standard UT technique (see *Publication 80/P – Non-destructive Testing*) can be an alternative to 18.6.3.1 a), b) and c).

18.6.4 Selection of brittle crack arrest steels

18.6.4.1 The brittle crack arrest steels fitted in the upper deck region of container ships (see structural members defined in 18.6.1.1) are to comply with Table 18.6.4 where suffixes BCA1 and BCA2 are defined in Part IX of the Rules.

18.6.4.2 The brittle crack arrest steel property is to be selected for each individual structural member with thickness above 50 mm according to Table 18.6.4.

Table 18.6.4
Brittle crack arrest steel requirement in function of structural members and thickness

Structural members plating (*)	Thickness t [mm]	Steel grade required
Upper deck	$50 < t \leq 100$	YP36 or YP40, type BCA1
Hatch coamings side	$50 < t \leq 80$	YP40 or YP47, type BCA1
	$80 < t \leq 100$	YP40 or YP47, type BCA2
(*) – Excluding their attached longitudinals		

18.6.4.3 When brittle crack arrest steels as specified in Table 18.6.4 are used, the weld joints between the hatch coaming side and the upper deck are to be partial penetration weld details approved by PRS.

In the vicinity of ship block joints, alternative weld details may be used for the deck and hatch coaming side connection provided additional means for preventing the crack propagation are implemented and agreed by PRS in this connection area.

18.6.5 Controlling Parameters for the Application of Brittle Crack Arrest Measures

The thickness and the yield strength shown in Table 18.6.5 apply to the hatch coaming top plating and side plating are the controlling parameters for the application of brittle crack arrest measures.

If as built thickness of the hatch coaming top plating and side plating is below the values contained in the table, countermeasures are not necessary regardless of the thickness and yield strength of the upper deck plating.

Table 18.6.5

Yield strength (MPa)	Thickness (mm)	Option	Measures			
			1	2	3 + 4	5
355 (YP36)	$50 < t \leq 85$	–	N.A.	N.A.	N.A.	N.A.
	$85 < t \leq 100$	–	X	N.A.	N.A.	N.A.
390 (YP40)	$50 < t \leq 85$	–	X	N.A.	N.A.	N.A.
	$85 < t \leq 100$	A	X	N.A.	X	X
B		X*	N.A.**	N.A.	X	
460 (YP47) Flux Cored Arc Welding	$50 < t \leq 100$	A	X	N.A.	N.A.	X
		B	X*	N.A.**	N.A.	X
460 (YP47) Electro-Gas Welding	$50 < t \leq 100$	–	X	N.A.	X	X

Description of measures:

- 1 NDT other than visual inspection on all target block joints during construction. See *Publication 80/P – Non-destructive Testing*;
- 2 Periodic NDT other than visual inspection on all target block joints (after delivery). See *Publication 80/P – Non-destructive Testing*;
- 3 Brittle crack arrest design against straight propagation of brittle crack along weld line to be taken during construction. See 18.6.3.1 a), b) and c);
- 4 Brittle crack arrest design against deviation of brittle crack from other weld areas such as fillets and attachments welds during construction. See 18.6.3.2.
- 5 Brittle crack arrest design against propagation of cracks from “other weld areas” (18.6.2.3) such as fillets and attachment welds (during construction). See 18.6.3.2

Symbols:

X – to be applied;

N.A. – need not be applied;

A, B – selectable from option “A” or “B”;

* – see 18.6.2.3

** – may be required at the discretion of PRS

19 PASSENGER SHIPS, FERRIES AND RO-RO SHIPS

19.1 General

19.1.1 Application

19.1.1.1 The requirements specified in the present Chapter apply to passenger ships and to ships for horizontal mode of loading: roll on/roll off ships and ferries. The requirements specified below shall be regarded as supplementary to the basic requirements specified in Chapters 1÷17.

On ships subject to SOLAS Convention, the applicable requirements for equipment in the hull construction of passenger ships, given in Chapter 13 of Part III of the Rules shall be met (SOLAS II-1, Part B-2).

19.1.1.2 Passenger ships engaged on domestic voyages and assigned in the symbol of class, in addition to the mark **PASSENGER SHIP**, one of the following additional marks: **Class A**, **Class B**, **Class C** or **Class D**, shall comply with the applicable requirements of this Part of the *Rules* and *Publication 100/P*.

19.1.2 Structural Arrangement

Standard structural arrangement of a ship for horizontal mode of loading includes a multi-deck structure with double bottom and side tanks extended to the lowest deck.

If cargo decks are supported by pillars, the pillars shall be arranged in line from the deck to the bottom or to a supporting bulkhead.

In ships with a limited number of effective transverse bulkheads, partitions, web frames and web beams shall give the hull girder a sufficient transverse strength.

Longitudinal framing in bottom and upper deck is recommended.

19.1.3 Classification

19.1.3.1 Ships complying with the relevant requirements of the present Chapter may be affixed with additional mark in the symbol of class:

PASSENGER SHIP

RO-RO SHIP

FERRY

SD – ship with strengthened deck intended for the carriage of wheeled vehicles (on decks).

19.1.3.2 Marks **RO-RO SHIP** or **FERRY** mean that all cargo decks meet the requirements sufficient for affixing mark **SD**. In such case mark **SD** will not be entered into the ship's *Certificate of Class*.

19.1.3.3 Ships (ferries) carrying vehicles on weather decks may operate only in restricted area **II** and **III**.

19.1.3.4 Ships meeting the requirements specified for two or more ship types are affixed with combination of additional marks according to paragraph 3.4.2.3, *Part I – Classification Regulations*.

19.1.4 Documentation

Technical documentation, within the scope determined in 1.4.2, shall be submitted for consideration and approval.

19.1.5 General Requirements

19.1.5.1 Cargo ports shall comply with the requirements specified in *Part III – Hull Equipment*.

19.1.5.2 The structure of movable car decks, platforms, car deck pontoons, etc. shall comply with the requirements specified in *Part III – Hull Equipment*.

19.1.5.3 In ships intended for the carriage of rail vehicles, structures supporting rails and securing arrangement for rail cars are subject to PRS consideration in each particular case. Each railway rail shall be supported by deck longitudinal.

19.1.5.4 In passenger ships, forepeak or collision bulkhead shall be fitted which shall be watertight up to the bulkhead deck.

Location of the bulkhead shall comply with the requirements specified in 9.2.2.2.

In passenger ships, an after peak bulkhead, watertight up to the bulkhead deck, shall also be fitted.

The bulkhead may be stepped, provided that the safety of the ship as regards subdivision will not thereby be impaired.

19.1.5.5 Where a long forward superstructure is fitted, the forepeak or collision bulkhead on all passenger ships shall be extended weathertight to the next full deck above the bulkhead deck. The extension shall be so arranged as to preclude the possibility of the bow door causing damage to it in the case of damage to, or detachment of, a bow door.

19.1.5.6 The extension required in 19.1.5.5 need not be fitted directly above the bulkhead below, provided that all parts of the extension are not located forward of the forward limit specified in 19.1.5.4 (see also 9.2.2.4).

19.1.5.7 A double bottom in passenger ships shall comply with the requirements of 6.1.2.

19.1.5.8 Ro-ro passenger ships of 130 m in length and upwards shall be fitted with helicopter landing area meeting the requirements specified in sub-chapter 8.8.

Length L defined in 1.2.2 shall be taken as the ship's length.

19.1.5.9 The stern gland shall be situated in a watertight shaft tunnel or other watertight space separate from the stern tube compartment and of such volume that, if flooded by leakage through the stern gland, the bulkhead deck will not be submerged.

19.1.5.10 Where the whole or part of a ventilation trunk, tunnel or duct is located on the ro-ro deck, the structure of the trunk, tunnel or duct shall be capable of withstanding impact pressures due to sea water accumulated on the ro-ro deck, assumed for damage calculations in accordance with *Part IV – Stability and Subdivision*.

The pressures determined in 16.3.3 shall be taken as slamming pressures.

19.1.5.11 PRS may require that on passenger ships partial watertight bulkheads or barriers above the bulkhead deck should be fitted to confine the volume or movement of sea water accumulated in a compartment above the bulkhead deck.

The structures, referred to above, fitted above the transverse bulkheads or as close as possible to these bulkheads shall be provided with watertight plating and they shall be watertightly connected with the deck to limit the spread of sea water along the bulkhead deck when the ship is listed or trimmed.

If a partial watertight bulkhead is not fitted immediately above the transverse bulkhead, provision shall be made for part of the deck between these bulkheads to be watertight.

19.2 Materials and Welding

19.2.1 Fixed equipment (permanently attached to the hull structure) for securing of vehicles and cargo shall be made of steel of grade complying with the requirements of Chapter 2. Application of other steel grades and materials is subject to PRS consideration in each particular case.

19.2.2 Castings connected to the hull structure and forming the fixed equipment for securing of vehicles and cargo shall comply with the requirements specified in *Part IX – Materials and Welding*.

19.2.3 Welding of structural members and fixed equipment for securing vehicles and cargo shall comply with the requirements specified in Chapter 4.

19.2.4 Cut-outs shall not be applied in places where primary supporting members and stiffeners are attached to the deck plating strengthened for the wheeled vehicles. Normally double continuous fillet weld shall be applied. Double intermittent fillet weld may be applied subject to PRS consideration in each particular case.

19.3 Zone Strength

19.3.1 Direct stress analysis methods, design loads and allowable stresses shall comply with the below specified requirements and those specified in sub-chapters 14.3 and 14.4.

19.3.2 The scantlings of the following structural members shall be based on the structural strength analysis:

- transverse primary supporting members in ships with a small number of transverse bulkheads,
- primary supporting members in decks strengthened for the wheeled vehicles if they form part of a complex primary supporting member system or are unevenly loaded,
- supports and suspensions in movable car decks, deck and bottom structures if such calculations are considered necessary.

19.3.3 Structural strength analysis of transverse primary supporting members in ships provided with a small number of transverse bulkheads shall be carried out for the ship in heeled and upright positions. The values of stresses shall not exceed the allowable stresses specified in 14.5.

19.3.4 The scantlings of the deck primary supporting members for the wheel loading (also cars) shall be based on the most severe conditions of moving or stowed vehicles and on the unevenly distributed load.

19.3.5 Calculation methods recommended by PRS are specified in *Publication 17/P – Zone Strength Analysis of Hull Structure of Roll on/Roll off Ships* and in sub-chapters 14.3 and 14.4.

19.4 Permanent Decks for Wheel Loading

19.4.1 General Provisions

19.4.1.1 The present requirements cover structure strengthenings for direct wheel loads from cargo handling vehicles, or from cargo transporting vehicles kept on board and supported on their wheels when the ship is at sea, as well as loads from rail car wheels. Loadings from vehicles supported by crutches, horses, etc., are subject to PRS consideration in each particular case.

19.4.1.2 The strength requirements are based on the assumption that the considered element (plate or stiffener) is subjected to one or several wheel prints and that the element is continuous in both directions across several evenly spaced supports such as stiffeners, primary supporting members, etc. The requirements for other loads and/or boundary conditions is subject to PRS consideration in each particular case.

19.4.2 Deck Plating

The thickness of the deck plating subjected to wheel loading shall not be less than:

$$t = 58K_1 \sqrt{\frac{K_2 Q_s}{m R_e}} + t_k \quad [\text{mm}] \quad (19.4.2)$$

K_1 – numeric factor to be determined as follows:

- the minimum values of K_1 to be applied for plating of all decks, except the upper deck, are:

$K_1 = K_{1\min} = 1.0$ – for harbour conditions, for loads during loading and unloading,

$K_1 = K_{1\min} = 1.075$ – for sea conditions, for loads from carried vehicles;

- for upper deck plating amidships

$$K_1 = \frac{1}{\sqrt{K_0}} \quad [\text{mm}]$$

however, not less than $K_{1\min}$ values specified above.

The values of K_0 shall be taken in accordance with Table 19.4.2.

Table 19.4.2
Values of K_0

Deck framing system	Service conditions	
	Harbour	Sea
Longitudinal	$K_0 = 1 - 0.05 \frac{W}{W_r}$	$K_0 = 0.92 - 0.16 \frac{W}{W_r}$
Transverse	$K_0 = 1 - 0.23 \frac{W}{W_r}$	$K_0 = 0.86 - 0.36 \frac{W}{W_r}$

W – the required value of the hull section modulus amidships, [cm³], determined according to 15.2.1;

W_r – the actual value of the hull section modulus amidships, [cm³], determined according to 15.7.

- for the upper deck plating at the ship's ends, the minimum values of K_1 specified above, shall be applied;

- the values of K_1 vary linearly between the midship and the ship's ends;

$K_2 = 1.25 - 0.5 s/l$ for $s/l > 0.5$,

$K_2 = 1$ for $s/l \leq 0.5$;

l – spacing of primary supporting members, [m];

s – spacing of beams, [m];

Q – design load according to paragraph 19.6.2;

R_e – yield stress of the plating material, [MPa] (see 2.2);

m – coefficient determined in the following way:

- if only one wheel print or a group of wheel prints is within the panel width (see Fig. 19.4.2-1 and paragraph 19.6.1.2), then:

$$m = \frac{5.85}{1 - 0.57 \frac{b}{s}} \quad \text{for } b/s < 1$$

$$m = 29.47 - \frac{b}{s} \left[23.65 - 8.75 \frac{b}{s} + 0.97 \left(\frac{b}{s} \right)^2 \right] \quad \text{for } 1 \leq b/s \leq 3.35$$

$$m = 12 \quad \text{for } b/s > 3.35$$

- b – dimension of wheel print measured perpendicularly to stiffeners (Fig. 19.4.2-1);

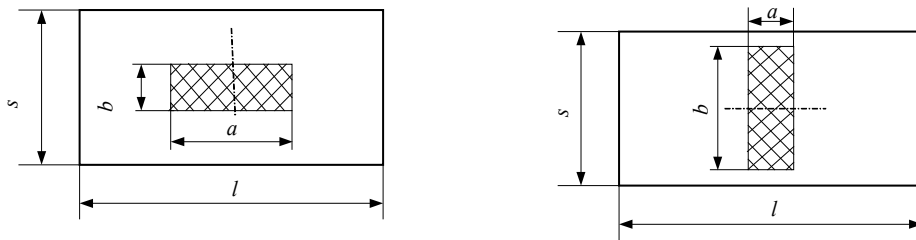

a) Axis of wheel rotation perpendicular to stiffeners

b) Axis of wheel rotation parallel to stiffeners

Fig. 19.4.2-1

- if several wheel prints or groups of wheel prints are within the panel width (see Fig. 19.4.2-2), then:

$$m = \frac{5.85}{1 - 0.57 \frac{b}{s} - \frac{K_3 e_s}{s}};$$

$$K_3 = \frac{b_s}{b} - 1 \quad \text{for } 1 \leq \frac{b_s}{b} \leq 2;$$

$$K_3 = 0.5 \frac{b_s}{b} \quad \text{for } \frac{b_s}{b} > 2;$$

b_s, e_s – dimensions of wheel prints, see Fig. 19.4.2-2, [m].

If the wheel print dimensions are determined in accordance with 19.6.1.4, then the plating thickness, determined from formula 19.4.2, shall be increased by 15%.

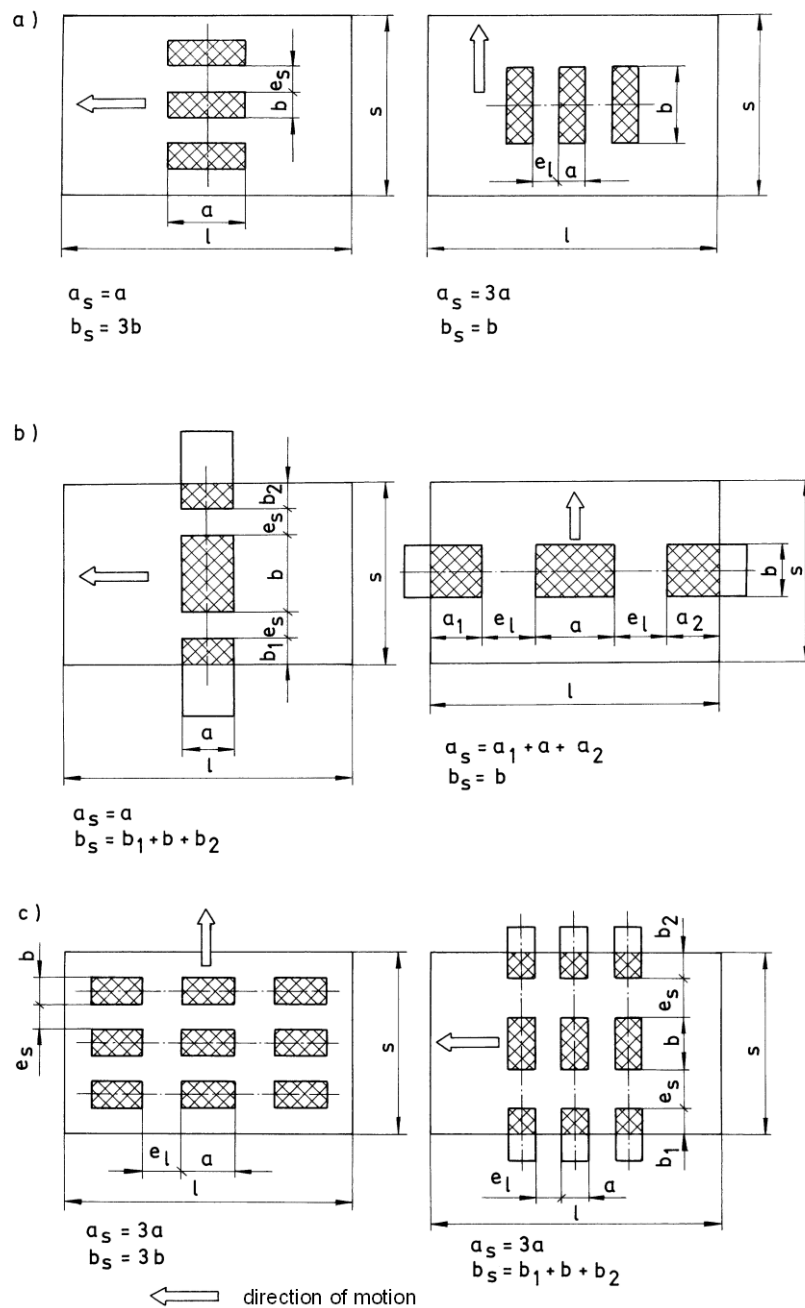

Fig. 19.4.2-2

19.4.3 Deck Beams and Longitudinals

19.4.3.1 Net section modulus (i.e. after deduction of corrosion additions according to 2.5) of the deck beams and longitudinals subjected to wheel load shall not be less than:

$$W = \frac{1000Ql}{mKR_e} \quad [\text{cm}^3] \quad (19.4.3.1)$$

Q – design load [kN], determined in accordance with paragraph 19.6.3;
 l – span of beams or longitudinals [m];

R_e – yield stress of the material [MPa] (see 2.2);

m – coefficient determined as follows:

- if only one wheel print or a group of wheel prints is along the length l (see Fig. 19.6.3 and paragraph 19.6.1.2), then:

$$m = \frac{5.85}{1 - 0.57 \frac{a}{l}} \text{ for } a/l < 1;$$

$$m = 29.47 - \frac{a}{l} \left[23.65 - 8.75 \frac{a}{l} + 0.97 \left(\frac{a}{l} \right)^2 \right] \text{ for } 1 \leq a/l \leq 3.35;$$

$m = 12$ for $a/l > 3.35$;

- if several wheel prints or a group of wheel prints are along the panel length l (see Fig. 19.6.3), then:

$$m = \frac{5.85}{1 - 0.58 \frac{a_s}{l} - \frac{K_4 e_l}{l}}$$

$$K_4 = \frac{a_s}{a} - 1 \text{ for } 1 \leq a_s/a \leq 2;$$

$$K_4 = 0.5 \frac{a_s}{s} \text{ for } a_s/a > 2;$$

a_s – see Fig. 19.4.2-2, [m];

e_l – distance, measured along the deck beam, between the adjacent wheel prints or groups of wheel prints along the length l [m] (see Fig. 19.6.3);

K – allowable stress factor determined as follows:

- for deck longitudinals amidships – from Table 19.4.3.1; the assumed values shall not exceed K_{\max} ;
- for deck longitudinals at the ship's ends: $K = K_{\max}$; the values of K vary linearly between the midship part and ship's ends;
- for deck beams: $K = K_{\max}$.

Table 19.4.3.1
Values of K for deck longitudinals amidships

Deck longitudinals	Service conditions	
	Sea	Harbour
Any deck	$0.96 - 0.56 \frac{W}{W_r}$	$0.96 - 0.36 \frac{W}{W_r}$
K_{\max}	0.7	0.8

W – the required value of the hull section modulus amidships, [cm³], determined according to 15.2.1;

W_r – the actual value of the hull section modulus amidships, [cm³], determined according to 15.7.

19.4.3.2 If the dimensions of wheel prints have been determined in accordance with 19.6.1.4, then the section modulus, determined in accordance with formula 19.4.3.1, shall be increased by 15%.

19.4.3.3 The values of coefficient m , which shall be used where the deck stiffeners shall not be considered as fixed to each girder, shall be agreed with PRS.

19.4.3.4 The section modulus W of deck longitudinals, [cm³], supporting the rail tracks shall not be less than that determined in accordance with formula 19.4.3.1 for the following parameters:

Q – according to 19.6.4;

$$m = \frac{5.85}{1 - K_5 \frac{e_l}{l}};$$

$K_5 = 0$ for $n_1 = 1$;

$K_5 = 0.5 n_1$ for $n_1 \geq 2$;

n_1 – see paragraph 19.6.4;

e_l – mean distance between centres of adjacent wheels within span l of deck stiffener, [m];

K – according to 19.4.3.1.

19.4.4 Primary Supporting Members

The scantlings of primary supporting members are subject to PRS consideration in each particular case taking into account the most severe conditions of moving or stowed (secured) vehicles.

The scantlings of the primary supporting members being part of a complex system shall be based on a zone strength analysis.

19.4.5 Connection between Stiffeners and Primary Supporting Members

Sectional area of the connections between stiffeners and primary supporting members is subject to PRS consideration in each particular case. Shear stresses shall not exceed 100 MPa in the stiffeners and primary supporting members to be joined and 115 MPa in the weld material.

19.5 Car Decks

19.5.1 General Requirements

19.5.1.1 The structure and scantlings of primary supporting members in the decks intended for the carriage of cars shall comply with the requirements concerning decks for wheel loading as specified in 19.4 and also the requirements specified below.

19.5.1.2 Fixed car decks with deck plating not welded to the supporting strength members, made of material other than steel, the strength of which is equal to that of the welded steel plating may be applied subject to PRS consideration in each particular case.

19.5.1.3 Other types and combinations of car decks and materials may be approved subject to PRS consideration in each particular case.

19.5.2 Design Loads

Design loads shall be determined in accordance with 19.6. For primary supporting members, the total load, including the cargo load (cars) and the mass of deck structure, shall be regarded as evenly distributed. Its value shall be determined in accordance with formula 16.4.1.1 assuming:

$$q = q_1 + q_0 \quad [\text{t/m}^2] \quad (19.5.2)$$

q_1 – distributed cargo load [t/m²];

q_0 – distributed mass of deck structure [t/m²].

The value of $(q_1 + q_0)$ shall be taken not less than 0.25 t/m².

19.5.3 Plating and Deck Beams

The scantlings of the plating and deck beams shall comply with the requirements specified in sub-chapters 19.4.2 and 19.4.3.

Where the stiffeners of movable decks are simply supported on web beams, then their section modulus shall be determined in accordance with formula 19.4.3.1 assuming:

$$m = \frac{8}{2 - \frac{a}{l}}$$

a – dimension of wheel print (or a group of wheel prints) parallel to the stiffeners [m] (see Fig. 19.6.3);

l – stiffener span [m].

19.5.4 Simple Primary Supporting Members

19.5.4.1 The required section modulus of the primary supporting member shall be determined as required in 13.6.2 assuming:

$\sigma = 160k$ [MPa];

$m = 12$ for primary supporting members with fixed ends,

$m = 8$ for primary supporting members with simply supported ends.

19.5.4.2 Effective cross-sectional area of the primary supporting member web shall not be less than that determined in accordance with formula 13.6.3.1 assuming:

$c = 1$;

$k_1 = 0.06$.

19.5.4.3 Moment of inertia of the primary supporting member section area shall not be less than that determined in accordance with the following formula:

$$I = C_1 W k l \quad [\text{cm}^4] \quad (19.5.4.3)$$

$C_1 = 1.1$ for steel,

$C_1 = 3.0$ for aluminium alloys;

W – primary supporting member section modulus according to 19.5.4.1 [cm³];

l – primary supporting member span [m].

19.5.4.4 Critical stress of the primary supporting member effective plate shall comply with the following condition:

$$\sigma_c \geq \frac{\sigma_a}{0.87} \quad [\text{MPa}] \quad (19.5.4.4)$$

σ_a – design compressive stress [MPa];

σ_c – critical stress determined in accordance with formula 13.3.2.2-1 or 13.3.2.2-2 assuming σ_E in accordance with formula 13.4.3.4-1 [MPa].

Tripping brackets and local stiffeners of plates shall be applied, where necessary.

19.5.5 Complex Primary Supporting Member System

The scantlings of the primary supporting members, being part of a complex system or unevenly loaded, shall be based on a zone strength analysis in accordance with the requirements specified in Chapter 14.

The allowable stresses shall be taken as follows:

- normal stresses: $\sigma = 160k$ [MPa];
- shear stresses: $\tau = 90k$ [MPa].

The requirements specified in paragraphs 19.5.4.3 and 19.5.4.4 shall also be complied with.

19.6 Design Loads

19.6.1 General Requirements

19.6.1.1 Design loads shall be determined in accordance with the technical data of vehicles.

When the arrangement and dimensions of wheel prints are not available, they shall be determined in accordance with 19.6.1.4.

19.6.1.2 Design loads shall be determined with regard to the pressure acting on the wheel print area, wheel print dimensions and the distance between wheel prints.

Where the distance e between the adjacent wheel prints is less than the width v_1 of a single wheel print, the loaded area may be considered as a single wheel print of a group of wheels (Fig. 19.6.1.2) having the dimensions u and v .

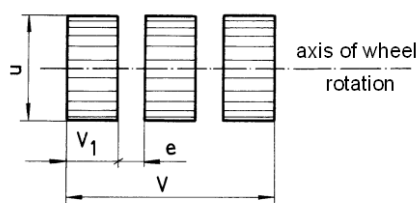

Fig. 19.6.1.2

The design area of a single wheel print or a group of wheel prints F shall be determined in accordance with the following formula:

$$F = uv \quad [\text{m}^2] \quad (19.6.1.2)$$

$v = v_1$ for a single wheel or where $e > v_1$ (see Fig. 19.6.1.2),

$v = n v_1 + (n - 1) e$ for a group of wheels, where $e \leq v_1$;

n – number of wheels in the group.

19.6.1.3 Design pressure p for a single wheel or a group of wheels shall be determined in accordance with the following formula:

$$p = K_d p_K \quad [\text{kPa}] \quad (19.6.1.3)$$

$K_d = \alpha_1 \alpha_2$ – coefficient taking into account dynamic loads during loading or unloading operations;

α_1 – coefficient equal to 1.1 or 1.05 – for vehicles (except fork lift trucks) with respective axle load not exceeding 50 kN and not less than 50 kN,

$\alpha_1 = 1$ – for fork lift trucks,

α_2 – coefficient equal to 1.03 or 1.15 for vehicles with pneumatic and solid tyres, respectively;

$\alpha_2 =$ coefficient equal to 1.25 for wheels with steel rims;

$$K_d = 1 + \frac{0.5a_v}{g} \quad \text{for sea conditions;}$$

a_v – vertical acceleration, [m/s²], determined in accordance with 17.4.1;

$$p_K = \frac{n}{n_0} \frac{Q_0}{F} \quad \text{– static pressure acting on the area of wheel print or a group of wheel prints;}$$

n_0 – number of wheels on an axle;

n – number of wheels in a group of wheels ($n = 1$ for a single wheel);

Q_0 – static load per axle of vehicle, [kN];

F – the area of wheel print or a group of wheel prints (see 19.6.1.2).

Where distribution of the load between wheeled vehicle axles is not uniform, Q_0 shall be taken equal to the maximum value.

In the case of forklift trucks, it shall be assumed that total load acts on the fore axle.

19.6.1.4 If the dimensions of vehicle wheel prints are not available, pressure P_K [kPa] may be taken in accordance with Table 19.6.1.4.

Table 19.6.1.4

Vehicle type	Tyre type	
	Pneumatic	Solid
Cars	200	–
Trucks	800	–
Trailers and semitrailers	800	1500
Fork lift trucks	800 (for $n = 1$)	1500
	600 (for $n \geq 2$)	1500

The area of a wheel print or a group of wheel prints shall be determined in accordance with the following formula:

$$F = \frac{n}{n_0} \frac{Q_0}{p_K} \quad [\text{m}^2] \quad (19.6.1.4-1)$$

n, n_0, Q_0 – as in 19.6.1.3.

Dimension u of the wheel print, perpendicular to the rotation axis, shall be determined in accordance with the following formulae (see Fig. 19.6.1.2):

– for wheels with solid tyres:

$$u = 0.01 \frac{Q_0}{n_0} \quad [\text{m}] \quad \text{where } Q_0/n_0 \leq 15 \text{ kN}, \quad (19.6.1.4-2)$$

$$u = 0.15 + 0.001 \left(\frac{Q_0}{n_0} - 15 \right) \quad [\text{m}] \quad \text{where } Q_0/n_0 > 15 \text{ kN};$$

– for wheels with pneumatic tyres:

$$u = 0.15 + 0.0025 \frac{Q_0}{n_0} \quad [\text{m}] \quad \text{where } Q_0/n_0 \leq 100 \text{ kN}, \quad (19.6.1.4-3)$$

$$u = 0.4 + 0.002 \left(\frac{Q_0}{n_0} - 100 \right) \quad [\text{m}] \quad \text{where } Q_0/n_0 > 100 \text{ kN.}$$

The dimension v of the wheel print, parallel to the rotation axis, shall be determined in accordance with the following formula:

$$v = \frac{F}{u} \quad [\text{m}] \quad (19.6.1.4-4)$$

19.6.1.5 When determining the design loads, the harbour loads (loading and discharging), as well as sea loads from the carried vehicles shall be taken into account.

Design loads shall be determined for two mutually perpendicular positions of wheel rotation axis with respect to the plate panel sides or stiffeners:

- wheel rotation axis parallel to the shorter side of the panel (perpendicular to the stiffeners),
- wheel rotation axis parallel to the longer side of the panel (parallel to the stiffeners).



Fig. 19.6.1.5

The arrangement of wheel prints within the panel width or the stiffener length, unless otherwise specified in the ship design, shall comply with the following requirements:

- for odd number of wheel prints, the centre of the middle wheel print shall coincide with the middle of the shorter side or stiffener (Fig. 19.6.1.5-a);
- for even number of wheel prints, the following two cases shall be taken into account:
 - the wheel prints shall be so arranged that their total length along the shorter panel side or along stiffener is the greatest (Fig. 19.6.1.5-b),
 - the number of wheel prints shall be reduced by one and the centre of the middle wheel print is in line with the middle of the shorter side of panel or stiffener (Fig. 19.6.1.5-c).

In all cases, wheel prints shall be so arranged that their total length along the longer side of the panel or plating section supported by stiffener is the greatest.

19.6.2 Design Load for Plating

The design load for plating Q shall be determined in accordance with the following formula:

$$Q = p C s_1 \quad [\text{kN}] \quad (19.6.2)$$

p – according to 19.6.1.3, [kPa];

$C = 1.35C_1 - 0.6C_1^2 + 0.09C_1^3$, however, not more than 1;

$C_1 = \frac{a}{s}$ where one wheel print acts along the longer side of the panel;

$C_1 = [C_2 - (C_2 - 1)C_3] \frac{a}{s}$ where more than one wheel print act along the longer side of the panel;

$C_2 = \frac{a_s}{s}$, a_s – see Fig. 19.4.2-2;

$C_3 = \frac{e_l}{a} \frac{1}{C_4}$ where $e_l/a < C_4$;

$C_3 = 1$ where $e_l/a \geq C_4$;

$C_4 = \frac{1-C}{C}$.

Note: C applied for determining C_4 shall be calculated for $C_1 = a/s$.

a – size of loaded area parallel to stiffeners, [m], (see Fig. 19.4.2-2);

s – spacing between stiffeners, [m], (see Fig. 19.4.2-2);

e_l – distance between wheel prints or groups of wheel prints, measured along the longer side of the panel, [m] (see Fig. 19.4.2-2).

s_1 – parameter to be determined in the following way:

– where a single wheel print or a group of wheel prints acts on the panel (Fig. 19.4.2-1):

$s_1 = b$ where $b < s$;

$s_1 = s$ where $b \geq s$;

– where several wheel prints act on the panel (see Fig. 19.4.2-2):

$s_1 = b$ where $b_s < s$,

$s_1 = s$ where $b_s \geq s$.

19.6.3 Design Loads for Stiffeners

The design load Q for stiffeners shall be determined in accordance with the following formula:

$$Q = K_p p s_1 l_1 \quad [\text{kN}] \quad (19.6.3)$$

$K_p = 1$ where $\frac{b}{s_p} < 1$ or $\frac{b}{s_p} \geq 3$;

$K_p = 1.3 - 0.3 \left(\frac{b}{s_p} - 2 \right)$ where $1 \leq \frac{b}{s_p} \leq 3$;

s_p – width of plating supported by the stiffener, [m];

p – according to 19.6.1.3, [kPa].

s_1 and l_1 – parameters, [m], to be determined in the following way:

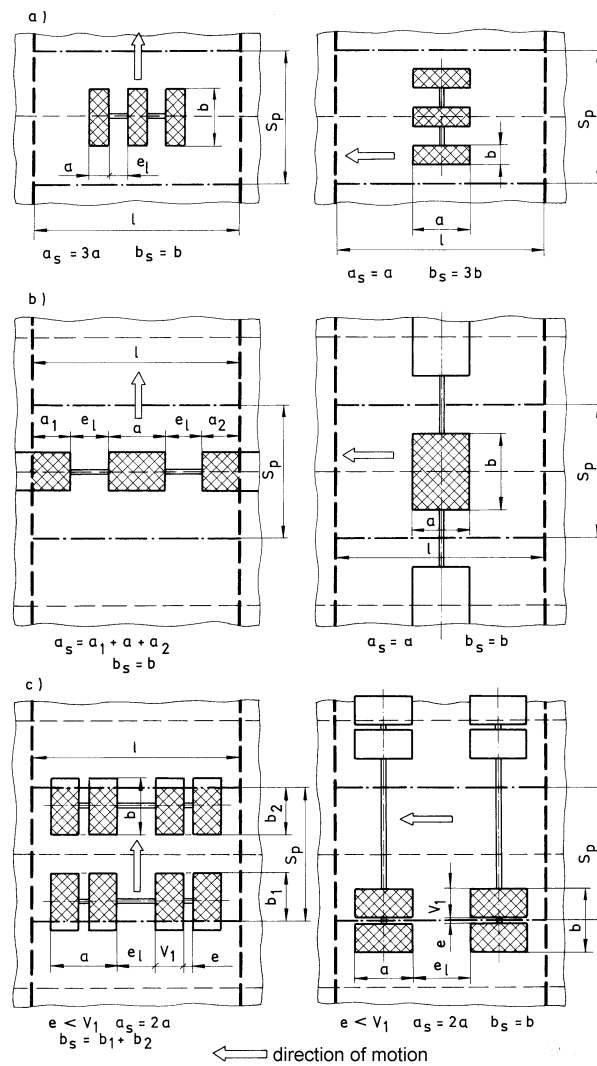

Fig. 19.6.3

- where a single wheel print or a group of wheel prints considered as a single wheel print act on the plating area supported by the stiffener, then (see Fig. 19.6.3):

$$s_1 = b \quad \text{where} \quad b < s_p;$$

$$s_1 = s_p \quad \text{where} \quad b \geq s_p;$$

$$l_1 = a \quad \text{where} \quad a < l;$$

$$l_1 = l \quad \text{where} \quad a \geq l;$$

- where several wheel prints act on the plating area supported by the stiffener, then (see Fig. 19.6.3):

$$s_1 = b_s \quad \text{where} \quad b_s < s_p;$$

$$s_1 = s_p \quad \text{where} \quad b_s \geq s_p;$$

$$l_1 = a_s \quad \text{where} \quad a_s < l;$$

$$l_1 = l \quad \text{where} \quad a_s \geq l.$$

19.6.4 Design Loads for Railway Tracks

The design load Q for railway tracks shall be determined in accordance with the following formula:

$$Q = 0.5CQ_0 n_1 \quad [\text{kN}] \quad (19.6.4)$$

$C = 1.1$ in harbour conditions (loading or discharging);

$C = 1 + \frac{0.5a_v}{g}$ in sea conditions;

a_v – vertical acceleration in the considered cross-section of the hull, calculated according to 17.4.1;

Q_0 – static load per one axle of rail vehicle, [kN];

n_1 – number of vehicle wheels arranged within the span l of stiffeners supporting rails.

20 BULK CARRIERS

20.1 General

20.1.1 Application

20.1.1.1 The requirements of the present Chapter apply to bulk carriers defined by SOLAS as those intended primarily for the carriage of dry cargo in bulk¹, constructed generally with single deck, top-side tanks and hopper side tanks in cargo spaces and including such types as ore carriers and combination carriers².

The requirements given below shall be regarded as supplementary to the basic requirements specified in chapters 1 to 17. Ships intended for alternate carriage of liquid and dry bulk cargoes shall also comply with the relevant requirements specified in Chapter 21.

20.1.1.2 Carriage of the following bulk cargoes: woodchips, cement, fly ash or sugar doesn't result in classifying the ship as a bulk carrier type, provided that loading and unloading is not carried out by grabs heavier than 10 tonnes, power shovels and other means which frequently damage cargo hold structures.

20.1.1.3 Ships not being bulk carrier type can occasionally carry dry cargoes in bulk, provided the conditions specified in Chapter 27 are complied with.

20.1.1.4 For bulk carriers³ having the length $L_0 \geq 90$ m, the requirements of CSR Rules shall be applied instead of the requirements specified in sub-chapters 20.1.4 to 20.1.7 and 20.2 to 20.12.

20.1.2 Structural Arrangement

20.1.2.1 A basic type of bulk carrier is a sea-going self-propelled ship with single deck, double bottom, topside and hopper tanks and with single (Fig. 20.1.2.1 a) or double side skin construction in cargo length area (Fig. 20.1.2.1 b), which is intended primarily to carry dry cargo in bulk.

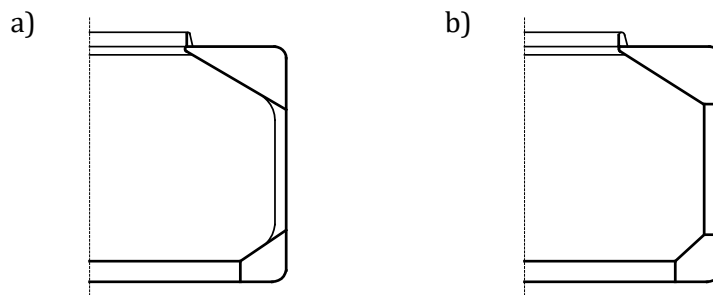

Fig. 20.1.2.1. Typical midship section of bulk carrier

20.1.2.2 A basic type of ore carrier is a sea-going self-propelled ship with single deck, two longitudinal bulkheads and a double bottom throughout the cargo length area and intended primarily to carry ore cargoes in the centre holds only. Typical midship sections of ore carriers are shown in Fig. 20.1.2.2.

¹ I.e. primarily designed to carry dry cargoes in bulk and to transport cargoes which are carried, and loaded or discharged, in bulk, and which occupy the ship's cargo spaces exclusively or predominantly.

² Ships are not considered outside the definition of bulk carriers on the grounds that they are not ore or combination carrier or that they lack some or all of the specified constructional features.

³ See bulk carrier definition in Common Structural Rules (CSR).

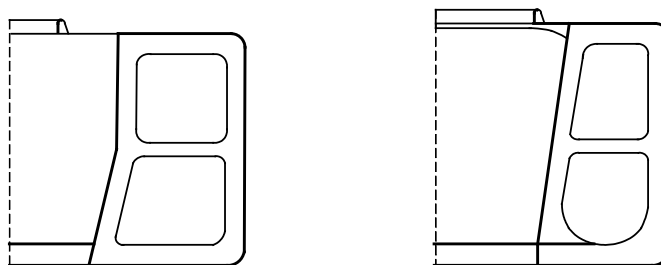

Fig. 20.1.2.2. Typical midship sections of ore carriers

20.1.2.3 Combination carrier is a ship intended for the carriage of both oil and dry cargoes in bulk. These cargoes are not carried simultaneously, with the exception of oil retained in slop tanks. Ore carriers/crude oil tankers and oil/bulk/ore (OBO) carriers, defined below, are considered as combination carriers.

A basic type of ore carrier/crude oil tanker is a sea-going self-propelled ship with single deck, two longitudinal bulkheads and a double bottom throughout the cargo area and intended primarily to carry ore cargoes in the centre holds or oil cargoes in centre holds and wing tanks.

Typical midship sections of ore carriers/crude oil tankers are shown in Fig. 20.1.2.3-1.

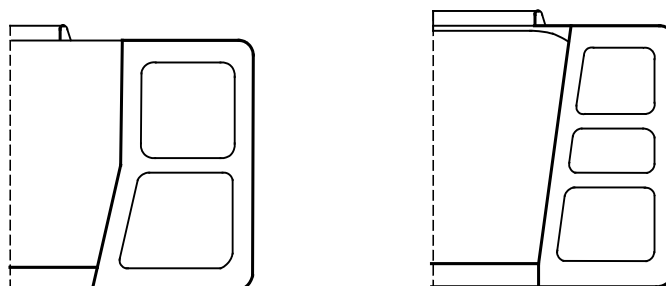

Fig. 20.1.2.3-1. Typical midship sections of ore carrier/crude oil tanker

A basic type of oil/bulk/ore carrier is a sea-going self-propelled ship with single deck, double bottom, hopper side tanks and topside tanks and with single or double side skin construction in the cargo length area. The ship is intended primarily to carry oil or dry cargoes, including ore, in bulk. Typical midship sections of oil//bulk/ore carriers are shown in Fig. 20.1.2.3-2.

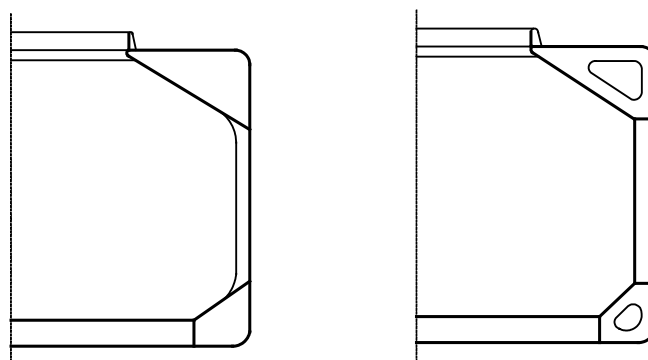

Fig. 20.1.2.3-2. Typical midship sections of oil//bulk/ore carriers

20.1.2.4 The construction of ships intended for alternate carriage of dry cargo and oil cargo shall be so modified with respect to the above mentioned structures as to fulfil also requirements for tankers specified in Chapter 21.

20.1.2.5 Bulk or ore carriers may have characteristic design solutions related to their ability for the carriage of one or more categories of bulk cargo. The above solutions are subject to PRS acceptance in each particular case.

20.1.3 Classification

20.1.3.1 Ships complying with the relevant requirements specified in this Chapter (or those specified in CSR) may be affixed with the following additional marks in the symbol of class:

ORE CARRIER – ship intended for the carriage of ore;

BULK CARRIER – ship intended for the carriage of other solid bulk cargoes; and ships arranged for alternate carriage of liquid and solid bulk cargo:

CRUDE OIL TANKER/ORE CARRIER – oil-ore carrier,

CRUDE OIL TANKER/ORE CARRIER/BULK CARRIER – oil-bulk-ore carrier.

20.1.4 General Requirements

20.1.4.1 Deck, double bottom, slopping bulkheads hopper and topside tanks, as well as a side in way of the tanks in question shall be arranged with longitudinal system of framing. A side situated between the hopper tank and the topside tank shall be arranged with the transverse system of framing. Double skin side structures may have longitudinal or transverse system of framing.

20.1.4.2 Side structures of the cargo holds bounded by the side shell only of bulk carriers constructed with single deck, topside tanks and hopper tanks in cargo spaces intended primarily to carry dry cargo in bulk, shall fulfil the requirements specified in sub-chapter 20.5.

20.1.5 Structural Particulars

20.1.5.1 Inner bottom plating shall be connected with hopper tank plating in the following way:

type A – rounded continuous connection (Fig. 20.1.5.1-a);

type B – welded connection (Fig. 20.1.5.1-b).

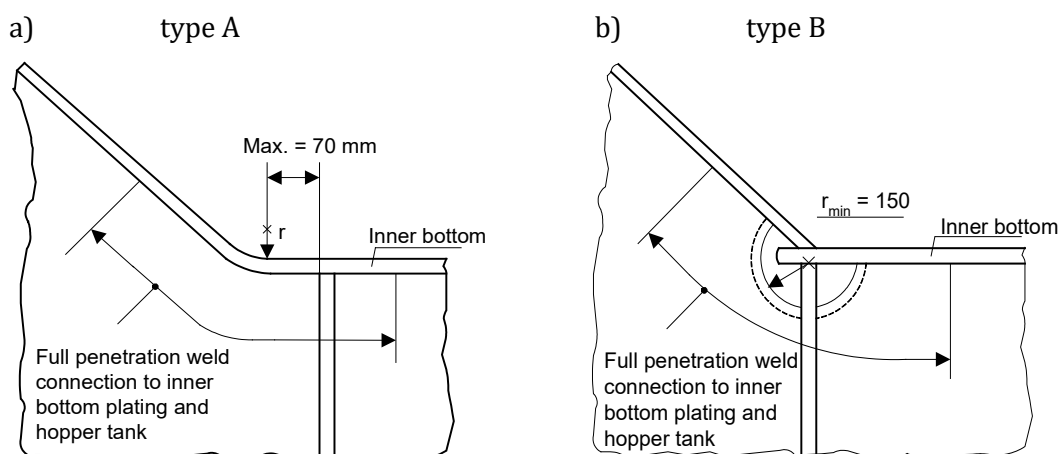

Fig. 20.1.5.1. Connection of inner bottom plating and hopper tank plating

20.1.5.2 No scallops may be applied in type A connections in floor and girder webs in hopper tanks. In way of the plating rounding, full penetration welding shall be applied. The distance between the rounding centre point and the longitudinal girder shall not exceed 70 mm.

20.1.5.3 Scallop in type B connections in floor and girder webs in hopper tanks (applied for the productivity purpose) shall be closed by welded collar plates.

In such cases the scallop radius shall not be less than 150 mm. Full penetration welding shall be applied for connections of floor and girder webs in hopper tanks and collar plates with plating.

20.1.5.4 Scallop in floor and girder webs may be applied provided the gusset plates shown in Fig. 20.1.5.4 are applied. It is recommended that gusset plates be integral part of inner bottom plating. Where the scallops are closed by collar plates in accordance with 20.1.5.3, the gusset plates are not required, however, intermediate brackets shall be applied in accordance with the requirements specified in paragraph 20.1.5.5.

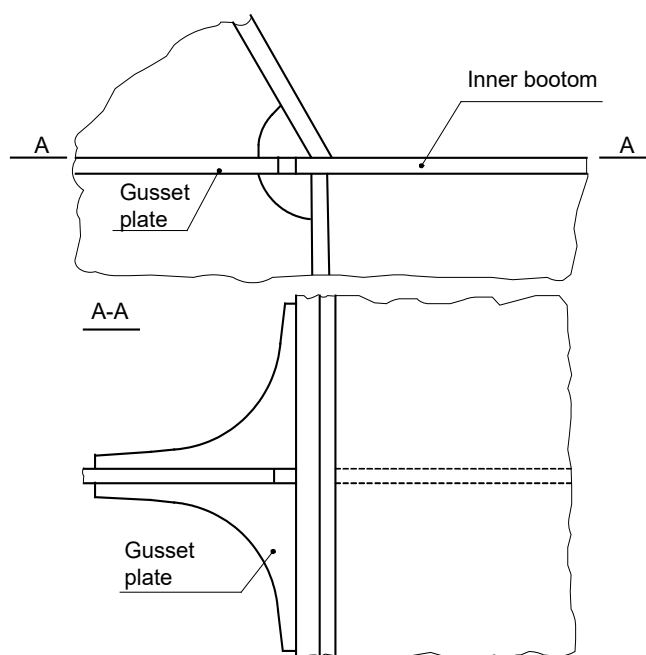

Fig. 20.1.5.4. Application of gusset plates in connection with scallops

20.1.5.5 Where the type A connection has been applied, brackets as shown in Fig. 20.1.5.5 shall be applied between floors. Distances between the brackets and between the brackets and adjacent floors shall not be greater than 1.0 m. Such brackets are also required in the case of type B connection with closed scallops, where gusset plates complying with the requirements specified in paragraph 20.1.5.4 have not been applied.

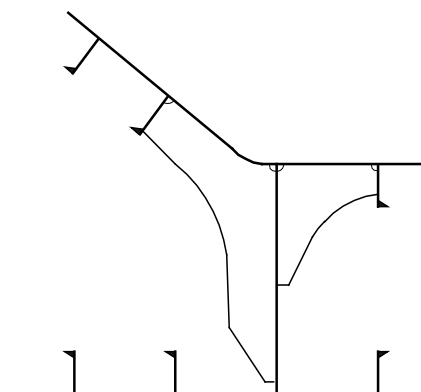

Fig. 20.1.5.5. Intermediate brackets

20.1.6 Corrosion Additions

20.1.6.1 The following corrosion additions, increased in relation to those specified in 2.5 are recommended:

- a) inner bottom plating and lowest parts of hopper tanks and bulkhead lower stools plating in holds – not less than 3.5 mm;
- b) other parts of hopper tanks and bulkhead lower stools plating in holds – not less than 2.0 mm.

Final values of applied corrosion additions for the hull elements specified above are subject to PRS acceptance in each case.

20.1.7 Documentation

20.1.7.1 Technical documentation, specified in sub-chapter 1.4.2, shall be submitted to PRS for consideration and approval.

20.2 Local Strength

20.2.1 The scantlings of structural members shall be determined in accordance with the requirements specified in Chapter 13, taking parameters in accordance with the requirements specified in the present sub-chapter.

As regards the construction of sides, bulkheads and bottom, the requirements specified in sub-chapters 20.5, 20.6, 20.7 and 20.8 also apply.

20.2.2 The thickness of the inner bottom plating shall not be less than that determined in accordance with formula 13.2.1 assuming:

$$k_1 = 0.03;$$

$$t_0 = 9.0 \text{ below cargo hatch way openings,}$$

$$t_0 = 8.0 \text{ elsewhere.}$$

20.2.3 The thickness of plating and geometrical properties of cross-sectional area of stiffeners shall be determined in accordance with the basic requirements taking design load values specified in sub-chapters 16.4.2 and 16.4.3, where applicable.

20.2.4 When determining the required thickness of inner and outer bottom plating for ships with transverse bottom framing, having additional mark HC/ALT or HC/E in the symbol of class, the following values of allowable stresses shall be taken (instead of those given in Table 13.4.2.2):

- for outer bottom $\sigma = 160k - 120f$, but not greater than $120k$;
- for inner bottom $\sigma = 185k - 110f$, but not greater than $140k$.

20.3 Zone Strength

20.3.1 Scope and Methods of Direct Calculations

The scantling of girders of double bottom, sides, hopper and topside tanks, decks and bulkheads should be verified with the use of direct calculations.

It is recommended to apply finite element method using models including three adjacent holds, with membrane or shell finite elements.

Modelling with the use of beam and rod finite elements – in accordance with *Publication 18/P – Zone Strength Analysis of Bulk Carrier Hull Structure* is also permitted.

The strength of the longitudinals in hopper and topside tanks, supporting side frame ends shall be verified with the use of direct calculations.

20.3.2 Loading Conditions

20.3.2.1 The minimum strength of double bottom in ships with additional mark **HC/ALT** in the symbol of class shall be based on the following loading condition: the hold under consideration empty, adjacent holds full. The load of the inner bottom in the full hold shall be not less than:

$$p_{dw} = g\rho(H - h_{dp}) \quad [\text{kPa}] \quad (20.3.2.1)$$

ρ – according to 16.4.2.2 or 16.4.3;

h_{dp} – mean height of double bottom in a hold, [m].

The load of the outer bottom shall be taken as equal to hydrostatic pressure at ship's draught $z = 0.8T$ [m].

20.3.2.2 The strength of double bottom structure in ships with additional mark **HC/E** in the symbol of class shall be determined on the basis of the following loading condition: full hold and the adjacent holds empty, full fuel or ballast tanks in the double bottom under the full hold.

The design draught shall be taken as follows:

- for determining the scantlings of the full hold bottom structure: the minimum possible draught shall be applied, maximum $z = 0.67T$ for harbour conditions;
- for determining the scantlings of the empty hold bottom structure: design draught T shall be applied.

20.3.3 For determining the scantlings of other structures, the most severe realistic loading conditions and arrangement of cargo, ballast, oil, etc. shall be applied.

20.4 Longitudinal Strength and Fatigue Strength

20.4.1 The design shear force curve, determined in accordance with the requirements specified in 15.9, may be corrected for the direct transmission of forces from the double bottom to the transverse bulkheads.

20.4.2 In the area between the fore bulkhead in aft cargo hold and aft bulkhead in fore cargo hold, the side plating thickness shall be not less than:

$$t = \frac{0.0036}{k} L_1 \sqrt[3]{LB} \quad [\text{mm}] \quad (20.4.2)$$

L_1 – see 13.1.2.

If the ratio between the cargo hold length and the ship's breadth exceeds 1, then the side plating thickness will be specially considered by PRS.

Outside the region mentioned above, the side plating thickness may vary linearly to give the shear area required by sub-chapter 15.11 at fore end of machinery space and aft end of fore peak or adjacent deep tank.

20.4.3 The fatigue strength of hull structural elements made of high strength structural steel shall be checked in accordance with the requirements specified in *Publication 45/P – Fatigue Strength Analysis of Ship Steel Hull Structure*.

In special cases the fatigue strength analysis may be required for structural elements made of normal strength steel.

20.5 Side Structures in Single Side Ships

20.5.1 Application

The requirements specified in sub-chapter 20.5 apply to the side structures of cargo holds bounded by the side shell only of bulk carriers constructed with single deck, topside tanks and hopper tanks in cargo spaces intended primarily to carry dry cargo in bulk.

20.5.2 Scantlings of Side Structure

The thickness of the side shell plating and the section modulus and shear area of side frames shall be determined in accordance with the requirements specified in Chapter 13.

The scantlings of side hold frames immediately adjacent to the collision bulkhead shall be increased in order to prevent excessive deformation imposed on the shell plating. As an alternative, supporting structures shall be fitted which maintain the continuity of forepeak stringers within the foremost hold.

20.5.3 Minimum Thickness of Frame Webs

The thickness of frame webs within the cargo area shall not be less than:

$$t_{w,\min} = 7.0 + 0.03L_0 \quad [\text{mm}] \quad (20.5.3)$$

L_0 – the Rule length, [m], as defined in 1.2, but need not be taken greater than 200;

C = 1.15–for the frame webs in way of the foremost hold,
1.0–for the frame webs in way of other holds.

20.5.4 Lower and Upper Brackets

The thickness of the frame lower brackets shall not be less than the greater of t_w and $t_{w,\min} + 2$ mm, where t_w is the fitted thickness of the side frame web. The thickness of the frame upper bracket shall not be less than the greater of t_w and $t_{w,\min}$.

Section modulus SM of the frame and bracket or integral bracket, and associated shell plating, at the locations shown in Fig. 20.5.4-1, shall not be less than twice the section modulus SM_F required for the frame midspan area.

Dimensions of the lower and upper brackets shall not be less than those shown in Fig. 20.5.4-2.

Structural continuity with the upper and lower end connections of side frames shall be ensured within topsides and hopper tanks by connecting brackets as shown in Fig. 20.5.4-3. The brackets shall be stiffened against buckling in accordance with the requirements specified in 13.8.

The section moduli of the side longitudinals and sloping bulkhead longitudinals which support the connecting brackets shall be determined in accordance with the requirements specified in sub-chapter 13.5 criteria with the span taken between transverses. Other arrangements may be adopted upon PRS' agreement. In such cases the section moduli values of the longitudinals should be large enough for effective supporting of the brackets.

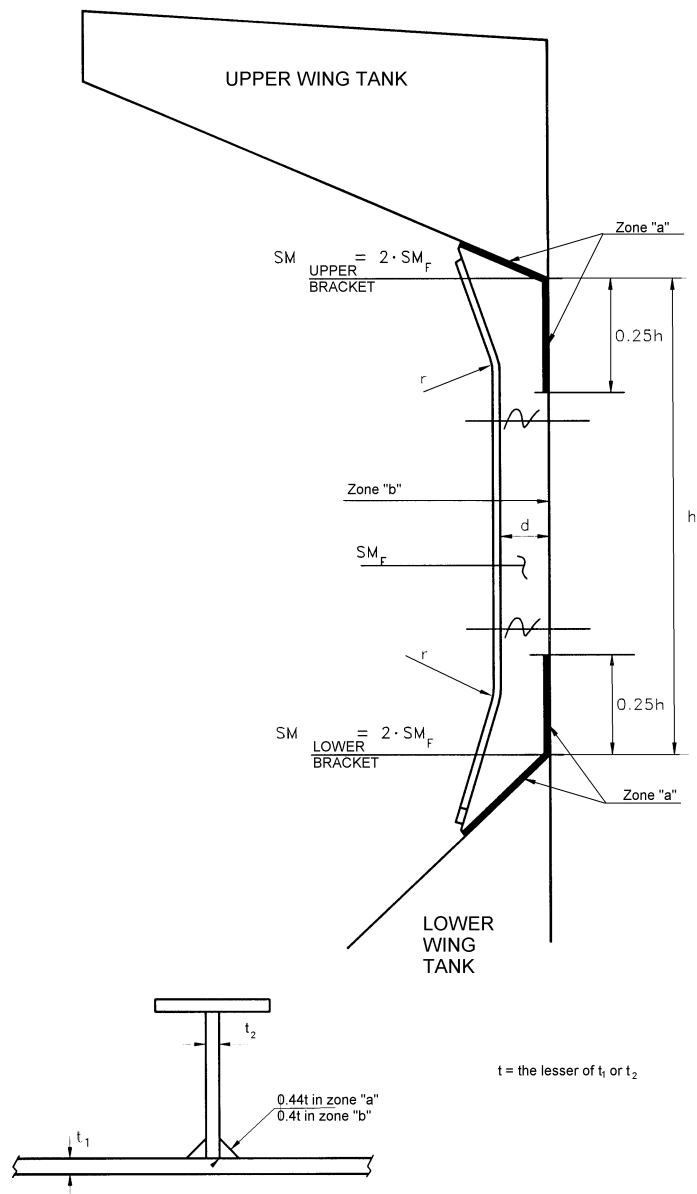

Fig. 20.5.4-1

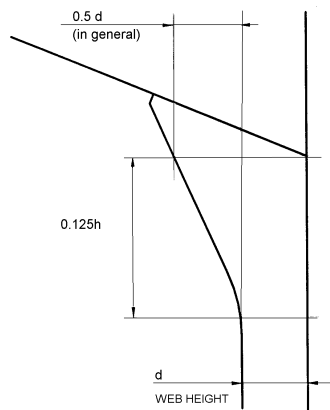

Fig. 20.5.4-2

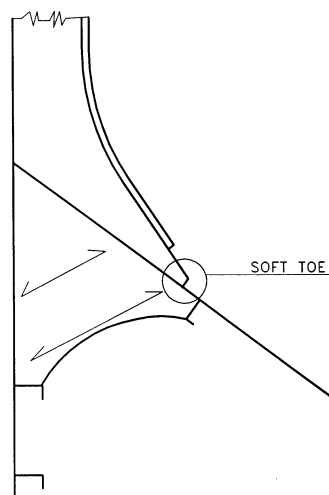

Fig. 20.5.4-3

20.5.5 Side Frame Sections

Frames shall be fabricated as symmetrical sections with integral upper and lower brackets and shall be arranged with soft toes (see Fig. 20.5.4-3).

Side frame flange shall be curved (not knuckled) at the connection with the end brackets. The radius of curvature shall not be less than:

$$r = \frac{0.4 \cdot b_f^2}{t_f} \quad [\text{mm}] \quad (20.5.5)$$

where b_f and t_f are the flange width and thickness of the brackets, respectively, in mm. The end of the flange shall be snipped.

In ships less than 190 m in length, mild steel frames may be asymmetric and fitted with separate brackets. The face plate or flange of the bracket shall be snipped at both ends. Brackets shall be arranged with soft toes.

The web depth to thickness ratio of frames shall not exceed the following values:

- $60/k^{0.5}$ for symmetrically flanged frames,
- $50/k^{0.5}$ for asymmetrically flanged frames,

where $k = 1.0$ for ordinary hull structural steel and $k > 1$ for higher tensile steel in accordance with the requirements specified in 2.2.

The outstanding flange shall not exceed $10 \cdot k^{0.5}$ times the flange thickness.

20.5.6 Tripping Brackets

In way of the foremost hold, side frames of asymmetrical section shall be fitted with tripping brackets at every two frames, as shown in Fig. 20.5.6.

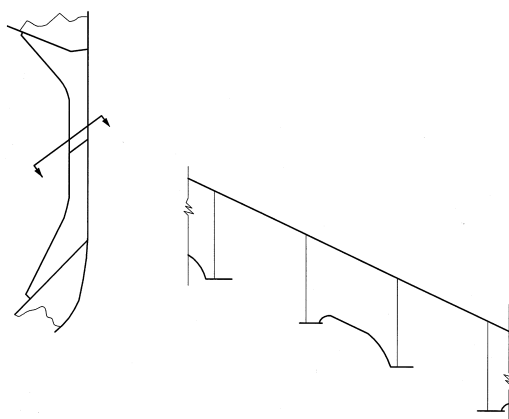

Fig. 20.5.6

20.5.7 Weld Connections of Frames and End Brackets

Double continuous welding shall be adopted for the connections of frames and brackets to side shell, hopper and upper wing tank plating and web to face plates.

For this purpose, the weld throat shall be (see Fig. 20.5.4-1):

- $0.44t$ in zone “a”,
- $0.4t$ in zone “b”,

where t is the thinner of the two connected members.

Where the hull form does not allow to apply an effective fillet weld, edge preparation of the web of frame and bracket may be required in order to ensure the same efficiency as the weld connection stated above.

20.5.8 Minimum Thickness of Side Shell Plating

The thickness of the side shell plating located between hopper and upper wing tanks shall not be less than:

$$t_{p,\min} = \sqrt{L_0} \quad [\text{mm}]. \quad (20.5.8)$$

20.6 Longitudinal Strength of Hull in Flooded Condition

20.6.1 Flooding Conditions

In bulk carriers of a length $L_0 \geq 150$ m intended for the carriage of dry bulk cargoes of a mass density 1.0 t/m^3 and above, having:

- a) single side shell, or
- b) double side shell so arranged that each portion of the longitudinal bulkhead is situated within $B/5$ or 11.5 m (whichever is less) measured horizontally from the ship's side inwards, perpendicularly to the centre plane, at the level of summer waterline,

each cargo hold shall be considered individually flooded up to the equilibrium waterline.

This application is to be also applied to self-unloading bulk carriers (SUBC), where the unloading system maintains the watertightness during seagoing operations.

In SUBCs with unloading systems that do not maintain watertightness, the longitudinal strength in the flooded conditions are to be considered using the extent to which the flooding may occur.

Such ships shall have their hull girder strength checked for the above flooded conditions, in each of the cargo and ballast loading conditions defined in 15.4.2 and in every other condition considered in the intact longitudinal strength calculations, including those according to *Publication 16/P – Loading Guidance Information*, except that harbour conditions, docking conditions, loading and unloading transitory conditions in port and loading conditions encountered during ballast water exchange need not be considered.

Still water loads in the flooded conditions shall be calculated for the above cargo and ballast loading conditions.

Wave loads in the flooded conditions are assumed to be equal to 80% of the maximum wave loads specified in Chapter 15.

20.6.2 Flooding Criteria

To calculate the weight of ingressed water, the following assumptions shall be made:

- .1 the permeability of empty cargo spaces and volume left in loaded cargo spaces above any cargo shall be taken as 0.95;
- .2 appropriate permeabilities and bulk densities shall be used for any cargo carried. For iron ore, a minimum permeability of 0.3 with a corresponding bulk density of 3.0 t/m³ shall be used. For cement, a minimum permeability of 0.3 with a corresponding bulk density of 1.3 t/m³ shall be used. In this respect, "permeability" for solid bulk cargo means the ratio of the floodable volume between the particles, granules or any larger pieces of the cargo, to the gross volume of the bulk cargo.

For packed cargo conditions (such as steel mill products), the actual density of the cargo shall be used with a permeability of zero.

20.6.3 Stress Assessment

The actual bending stress, σ_{fld} , at any location is given by:

$$\sigma_{fld} = \frac{M_{sf} + 0.8M_w}{W_z} 10^3 \text{ [MPa]} \quad (20.6.3-1)$$

where:

- M_{sf} – still water bending moment [kNm], in the flooded condition for the section under consideration;
- M_w – wave bending moment [kNm], as specified in 15.5.1 for the section under consideration;
- W_z – hull section modulus [cm³], for the corresponding location.

The shear strength of the side shell and the inner hull if any, at any location of the ship, shall be checked in accordance with the requirements specified in paragraph 15.11.1 or 15.11.2, where Q_s and Q_w shall be replaced by Q_{sf} and Q_{wf} , respectively, where:

- Q_{sf} – still water shear force, [kN], in the flooded condition for the section under consideration;
- $Q_{wf} = 0.8 Q_w$.
- Q_w – wave shear force for the section under consideration (see 15.10.1 and 15.10.2), [kN].

20.6.4 Strength Criteria

The damaged structure is assumed to remain fully effective in resisting the applied loading.

Allowable stress and axial stress buckling strength shall comply with the requirements specified in Chapters 13 and 15.

20.7 Evaluation of Scantlings of Corrugated Transverse Watertight Bulkheads in Bulk Carriers Considering Hold Flooding

20.7.1 Application and Definitions

20.7.1.1 The requirements specified in sub-chapters 20.7.2 to 20.7.6 shall be fulfilled in respect of flooding of any cargo hold of bulk carriers of 150 m in length and above, with single deck, topside tanks and hopper tanks, and of single side or double side skin¹ construction intended to carry solid bulk cargoes having a density of 1.0 t/m³, or above, with vertically corrugated transverse watertight bulkheads contracted for construction on 1 July 2006 or later.

The net thickness t_{net} is the thickness obtained by applying the strength criteria specified in 20.7.4.

The required thickness is obtained by adding the corrosion addition t_k , specified in sub-chapter 20.7.6, to the net thickness t_{net} .

Homogeneous loading condition, referred to in sub-chapter 20.7, means a loading condition in which the ratio between the highest and the lowest filling ratio, evaluated for each hold, does not exceed 1.20, (to be corrected for different cargo densities).

20.7.2 Load Model

20.7.2.1 General

The loads to be considered as acting on the bulkheads are those given by the combination of the cargo loads with those induced by the flooding of one hold adjacent to the bulkhead under examination. In any case, the pressure due to the flooding water alone shall be considered.

This application is to be also applied to self-unloading bulk carriers (SUBC), where the unloading system maintains the watertightness during seagoing operations.

In SUBCs, with unloading systems that do not maintain watertightness, the combination loads acting on the bulkheads in the flooded conditions are to be considered using the extent to which the flooding may occur.

The most severe combinations of cargo induced loads and flooding loads shall be used for the check of the scantlings of each bulkhead, depending on the loading conditions included in the loading manual:

- homogeneous loading conditions,
 - non-homogeneous loading conditions,
- considering the individual flooding of both loaded and empty holds.

The specified design load limits for the cargo holds shall be represented by loading conditions defined by the designer in the loading manual.

Non-homogeneous part loading conditions associated with multiport loading and unloading operations for homogeneous loading conditions need not be considered in accordance with these requirements. Holds carrying packed cargoes shall be considered as empty holds.

Unless the ship is intended to carry, in non-homogeneous conditions, only iron ore or cargo having bulk density equal or greater than 1.78 t/m³, the maximum mass of cargo which may be carried in the hold shall also be considered to fill that hold up to the upper deck level at centre plane.

¹ So arranged that each portion of the longitudinal bulkhead is situated within B/5 or 11.5 m (whichever is less) measured horizontally from the ship's side inwards, perpendicularly to the centre plane, at the level of summer waterline.

20.7.2.2 Bulkhead Corrugation Flooding Head

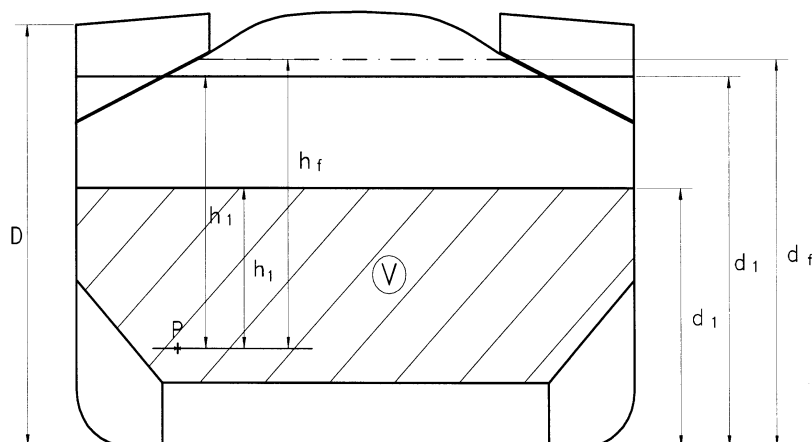

P = Calculation point

V = Volume of cargo

Fig. 20.7.2.2

Flooding head h_f (see Fig. 20.7.2.2) is the distance, in m, measured vertically with the ship in the upright position, from the calculation point to a level located at a distance d_f , in m, from the base plane equal to:

a) in general:

- D for the foremost transverse corrugated bulkhead,
- 0.9 for the other bulkheads.

Where the ship shall carry cargoes having bulk density less than 1.78 t/m^3 in non-homogeneous loading conditions, the following values can be assumed:

- $0.95D$ for the foremost transverse corrugated bulkhead,
- $0.85D$ for the other bulkheads;

b) for ships less than 50,000 tonnes deadweight with Type B freeboard:

- $0.95D$ for the foremost transverse corrugated bulkhead,
- $0.85D$ for the other bulkheads.

Where the ship shall carry cargoes having bulk density less than 1.78 t/m^3 in non-homogeneous loading conditions, the following values can be assumed:

- $0.9D$ for the foremost transverse corrugated bulkhead,
- $0.8D$ for the other bulkheads;

D being the distance, [m], from the base plane to the freeboard deck at side amidships (see Fig. 20.7.2.2).

20.7.2.3 Pressure in the Non-Flooded Bulk Cargo Loaded Holds

At each point of the bulkhead, the pressure p_c shall be determined in accordance with the following formula:

$$p_c = \rho_c g h_1 \tan^2 \gamma \quad [\text{kPa}] \quad (20.7.2.3-1)$$

where:

- ρ_c – bulk cargo density [t/m^3];
- g = 9.81 m/s^2 , gravity acceleration;

h_1 – vertical distance [m], from the calculation point to horizontal plane corresponding to the level height of the cargo (see Fig. 20.7.2.2), located at a distance d_1 [m], from the base plane;
 $\gamma = 45^\circ - (\phi/2)$;
 ϕ – angle of repose of the cargo, in degrees, that may generally be taken as 35° for iron ore and 25° for cement.

Force F_c , acting on a corrugation shall be determined in accordance with the following formula:

$$F_c = \rho_c g s_1 \cdot \frac{(d_1 - h_{DB} - h_{LS})^2}{2} \tan^2 \gamma \quad [\text{kN}] \quad (20.7.2.3-2)$$

where:

ρ_c, g, d_1, γ – as given above;

s_1 – spacing of corrugations [m], (see Fig. 20.7.2.3-1);

h_{LS} – mean height of the lower stool [m], from the inner bottom;

h_{DB} – height of the double bottom [m].

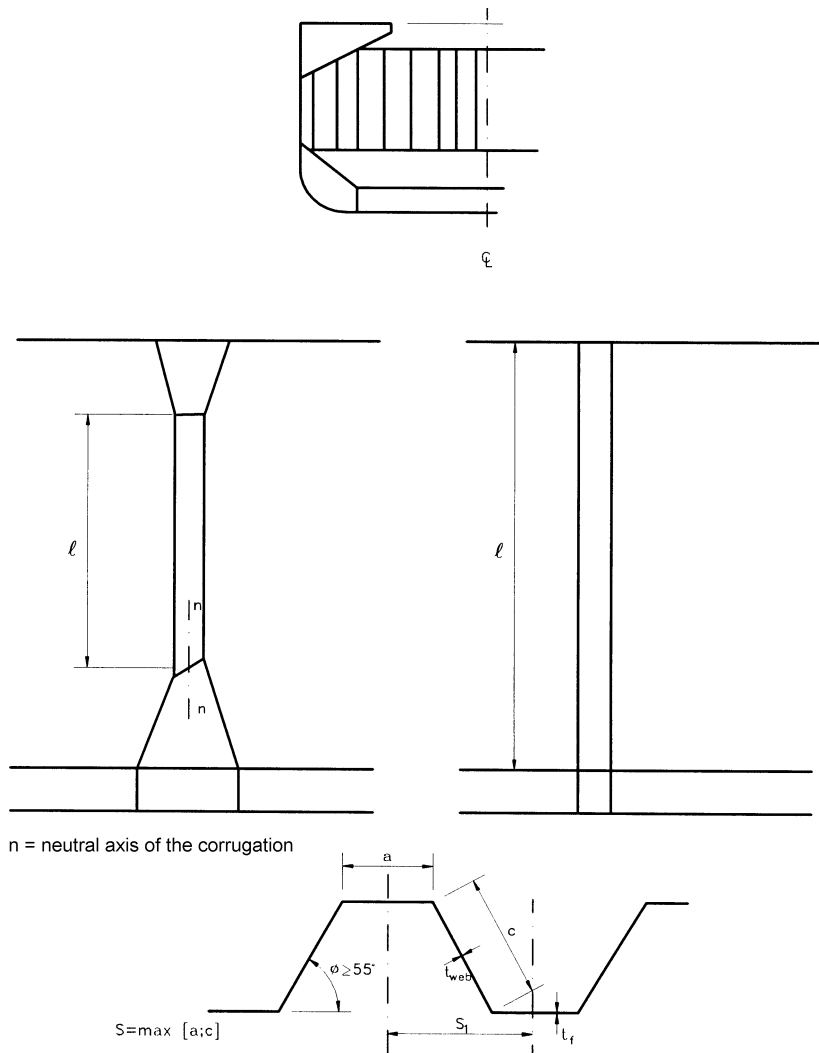

Fig. 20.7.2.3-1

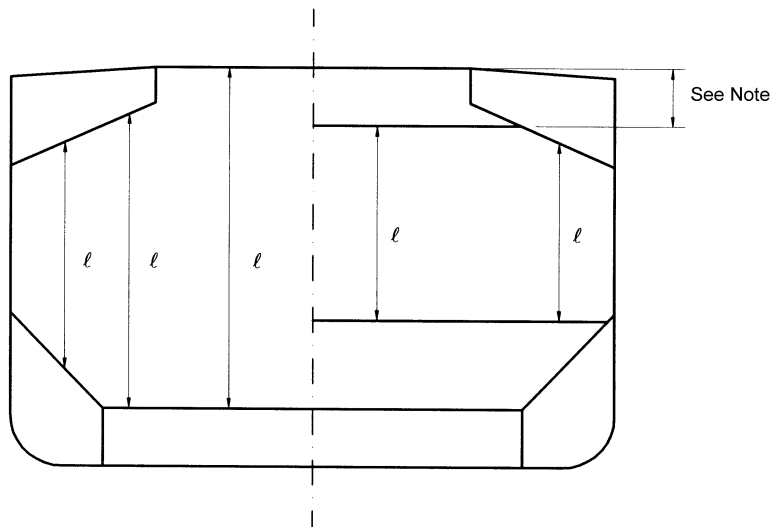

Fig. 20.7.2.3-2

Note:

For the definition of l , the internal end of the upper stool shall not be taken more than a distance from the deck at the centre plane equal to:

- 3 times the depth of corrugations, in general,
- 2 times the depth of corrugations, for rectangular stool.

20.7.2.4 Pressure in the Flooded Holds

20.7.2.4.1 Bulk Cargo Holds

Two cases shall be considered, depending on the values of d_1 and d_f :

- a) $d_f \geq d_1$

At each point of the bulkhead located at a distance between d_1 and d_f from the base plane, the pressure $p_{c,f}$ shall be determined in accordance with the following formula:

$$p_{c,f} = \rho g h_f \quad [\text{kPa}] \quad (20.7.2.4.1-1)$$

where:

- ρ – sea water density, [t/m³];
- g – as given in 20.7.2.3;
- h_f – flooding head as defined in 20.7.2.2.

At each point of the bulkhead located at a distance lower than d_1 from the base plane, the pressure $p_{c,f}$ shall be determined in accordance with the following formula:

$$p_{c,f} = \rho g h_f + [\rho_c - \rho(1 - \text{perm})] g h_1 \tan^2 \gamma \quad [\text{kPa}] \quad (20.7.2.4.1-2)$$

where:

- ρ, h_f – as given above;
- ρ_c, g, h_1, γ – as given in 20.7.2.3;
- perm – permeability of cargo, to be taken as 0.3 for ore (corresponding bulk cargo density for iron ore may generally be taken as 3.0 t/m³), coal cargoes and for cement (corresponding bulk cargo density for cement may generally be taken as 1.3 t/m³).

The force $F_{c,f}$ acting on a corrugation shall be determined in accordance with the following formula:

$$F_{c,f} = s_1 \left[\rho g \frac{(d_f - d_1)^2}{2} + \frac{\rho g (d_f - d_1) + (p_{c,f})_{le}}{2} (d_1 - h_{DB} - h_{LS}) \right] \text{ [kN]} \quad (20.7.2.4.1-3)$$

where:

ρ – as given above;

$s_1, g, d_1, h_{DB}, h_{LS}$ – as given in 20.7.2.3;

d_f – as given in 20.7.2.2;

$(p_{c,f})_{le}$ – pressure, [kPa], at the lower end of the corrugation.

b) $d_f < d_1$

At each point of the bulkhead located at a distance between d_f and d_1 from the base plane, the pressure $p_{c,f}$ shall be determined in accordance with the following formula:

$$p_{c,f} = \rho_c g h_1 \tan^2 \gamma \text{ [kPa]} \quad (20.7.2.4.1-4)$$

where:

ρ_c, g, h_1, γ – as given in 20.7.2.3.

At each point of the bulkhead located at a distance lower than d_f from the base plane, the pressure $p_{c,f}$ shall be determined in accordance with the following formula:

$$p_{c,f} = \rho g h_f + [\rho_c h_1 - \rho(1 - \text{perm}) h_f] g \tan^2 \gamma \text{ [kPa]} \quad (20.7.2.4.1-5)$$

where:

h_f, perm – see a) above;

ρ_c, g, h_1, γ – as given in 20.7.2.3.

Force $F_{c,f}$ acting on a corrugation shall be determined in accordance with the following formula:

$$F_{c,f} = s_1 \left[\rho_c g \frac{(d_1 - d_f)^2}{2} \tan^2 \gamma + \frac{\rho_c g (d_1 - d_f) \tan^2 \gamma + (p_{c,f})_{le}}{2} (d_f - h_{DB} - h_{LS}) \right] \text{ [kN]} \quad (20.7.2.4.1-6)$$

where:

$s_1, \rho_c, g, d_1, \gamma, h_{DB}, h_{LS}$ – as given in 20.7.2.3;

d_f – as given in 20.7.2.2;

$(p_{c,f})_{le}$ – pressure, [kPa], at the lower end of the corrugation.

20.7.2.4.2 Pressure in Empty Holds Due to Flooding Water Alone

At each point of the bulkhead, the hydrostatic pressure p_f induced by the flooding head h_f shall be considered.

Force F_f acting on a corrugation shall be determined in accordance with the following formula:

$$F_f = s_1 \rho g \frac{(d_f - h_{DB} - h_{LS})^2}{2} \text{ [kN]} \quad (20.7.2.4.2)$$

where:

s_1, g, h_{DB}, h_{LS} – as given in 20.7.2.3;

ρ – as given in 20.7.2.4.1 a);

d_f – as given in 20.7.2.2.

20.7.2.5 Resultant Pressure and Force

20.7.2.5.1 Homogeneous Loading Conditions

At each point of the bulkhead structures, the resultant pressure p , to be considered for the scantlings of the bulkhead, shall be determined in accordance with the formula:

$$p = p_{c,f} - 0.8p_c \quad [\text{kPa}]. \quad (20.7.2.5.1-1)$$

The resultant force F acting on a corrugation shall be determined in accordance with the following formula:

$$F = F_{c,f} - 0.8F_c \quad [\text{kN}]. \quad (20.7.2.5.1-2)$$

20.7.2.5.2 Non-Homogeneous Loading Conditions

At each point of the bulkhead structures, the resultant pressure p , to be considered for the scantlings of the bulkhead, shall be determined from the formula:

$$p = p_{c,f} \quad [\text{kPa}] \quad (20.7.2.5.2-1)$$

Resultant force F acting on a corrugation shall be determined from the formula:

$$F = F_{c,f} \quad [\text{kN}] \quad (20.7.2.5.2-2)$$

20.7.3 Bending Moment and Shear Force in the Bulkhead Corrugations

Bending moment M and shear force Q in the bulkhead corrugations shall be obtained using the formulae given in sub-chapters 20.7.3.1 and 20.7.3.2. The M and Q values shall be used for the checks in accordance with 20.7.4.5.

20.7.3.1 Bending Moment

Design bending moment M for the bulkhead corrugations shall be determined in accordance with the following formula:

$$M = \frac{Fl}{8} \quad [\text{kNm}] \quad (20.7.3.1)$$

where:

F – resultant force [kN], as in 20.7.2.5;

l – span of the corrugation [m], to be taken in accordance with Figures 20.7.2.3-1 and 20.7.2.3-2.

20.7.3.2 Shear Force

Shear force Q at the lower end of the bulkhead corrugations shall be determined in accordance with the following formula:

$$Q = 0.8F \quad [\text{kN}] \quad (20.7.3.2)$$

where:

F – as in 20.7.2.5.

20.7.4 Strength Criteria

20.7.4.1 General

The following criteria are applicable to transverse bulkheads with vertical corrugations (see Fig. 20.7.2.3-1). For ships of length 190 m and above, these bulkheads shall be fitted with a bottom stool, and generally, with a top stool below deck. For smaller ships, corrugations may extend from inner bottom to deck.

If the stool is fitted, it shall comply with the requirements specified in the present paragraph.

Corrugation angle ϕ , shown in Fig. 20.7.2.3-1, shall not be less than 55°.

The requirements for local net plate thickness are specified in 20.7.4.7.

In addition, the criteria specified in sub-chapters 20.7.4.2 and 20.7.4.5 shall be complied with.

Thicknesses of the lower part of corrugations considered in the application of 20.7.4.2 and 20.7.4.3 shall be maintained for a distance from the inner bottom (if no lower stool is fitted) or the top of the lower stool not less than 0.15*l*.

Thicknesses of the middle part of corrugations as considered in the application of 20.7.4.2 and 20.7.4.4 shall be maintained to a distance from the deck (if no upper stool is fitted) or the bottom of the upper stool not greater than 0.3*l*.

The section modulus of the corrugation in the remaining upper part of the bulkhead shall not be less than 75% of that required for the middle part, corrected for different yield stresses.

a) Lower stool

The height of the lower stool shall generally not be less than 3 times the depth of the corrugations. The thickness and material of the stool plate shall not be less than those required for the bulkhead plating above. The thickness and material of the upper portion of vertical or sloping stool side plating within the depth equal to the corrugation flange width from the stool top shall not be less than the required flange plate thickness and material to meet the bulkhead stiffness requirement at lower end of corrugation. The thickness of the stool side plating and the section modulus of the stool side stiffeners shall comply with the requirements specified in sub-chapter 9.4 for the design loads specified in 20.7.2 and allowable stresses determined in accordance with 13.4.2.3 or 13.5.2.1. The ends of stool side vertical stiffeners shall be attached to brackets at the upper and lower ends of the stool.

The distance from the edge of the stool top plate to the surface of the corrugation flange shall be in accordance with Fig. 20.7.4.1-1.

The stool bottom shall be installed in line with double bottom floors and shall have a width not less than 2.5 times the mean depth of the corrugation. The stool shall be fitted with diaphragms in line with the longitudinal double bottom girders for effective support of the corrugated bulkhead. Scallops in the brackets and diaphragms in way of the connections to the stool top plate shall be avoided.

Where corrugations are cut at the lower stool, corrugated bulkhead plating shall be connected to the stool top plate by full penetration welds.

The stool side plating shall be connected to the stool top plate and the inner bottom plating by either full penetration or deep penetration welds, in accordance with Fig. 20.7.4.1-2. The supporting floors shall be connected to the inner bottom by either full penetration or deep penetration welds, in accordance with Fig. 20.7.4.1-2.

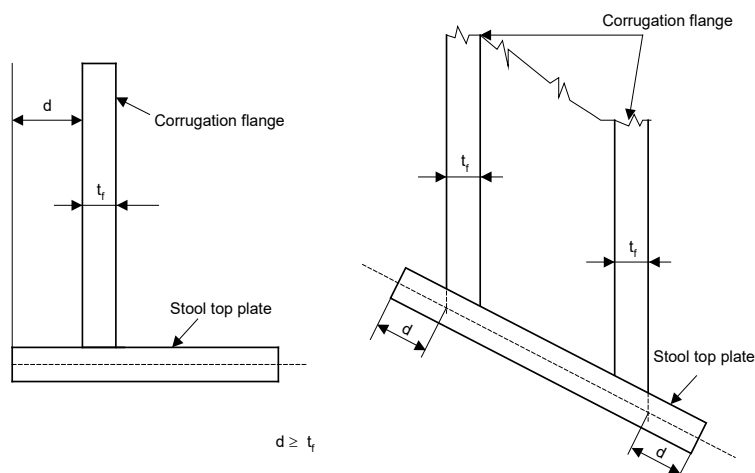

t_f – as built flange thickness

Fig. 20.7.4.1-1. Required distance, d , from the edge of stool top plate to the surface of corrugation flange

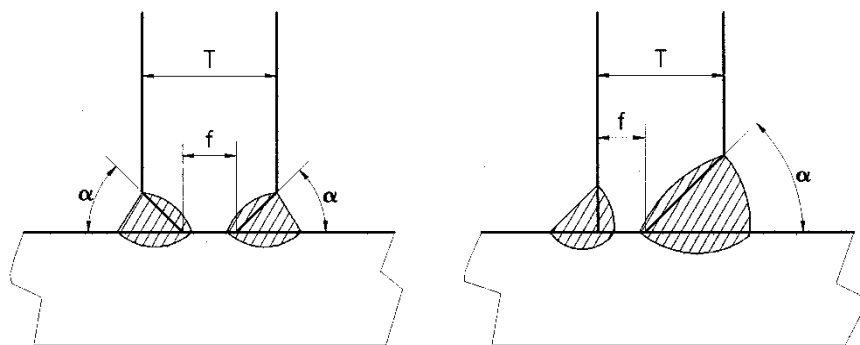

root face (f): 3 mm to $t/3$ mm
groove angle (α): 40° to 60°.

Fig. 20.7.4.1-2. Deep penetration weld

b) Upper stool

The upper stool, where fitted, shall have a height generally between 2 and 3 times the depth of corrugations. Rectangular stools shall have a height generally equal to 2 times the depth of corrugations, measured from the deck level and at hatch side girder. The upper stool shall be properly supported by girders or deep brackets between the adjacent hatch-end beams.

The width of the stool bottom plate shall generally be the same as that of the lower stool top plate. The stool top of non-rectangular stools shall have a width not less than 2 times the depth of corrugations. The thickness and material of the stool bottom plate shall be the same as those of the bulkhead plating below. The thickness of the lower portion of stool side plating shall not be less than 80% of that required for the upper part of the bulkhead plating where the same material is used. The thickness of the stool side plating and the section modulus of the stool side stiffeners shall comply with the requirements specified in sub-chapter 9.4 for the design loads defined in 20.7.2 and allowable stresses determined in accordance with the requirements specified in 13.4.2.3 or 13.5.2.1. The ends of stool side stiffeners shall be attached to brackets at upper and lower end of the stool. Diaphragms shall be fitted inside the stool in line with and effectively attached to longitudinal deck girders extending to the hatch end coaming girders for effective support of the corrugated bulkhead. Scallops in the brackets and diaphragms in way of the connection to the stool top plate shall be avoided.

c) Alignment

At deck, if no stool is fitted, two transverse reinforced beams shall be fitted in line with the corrugation flanges.

At bottom, if no stool is fitted, the corrugation flanges shall be in line with the supporting floors.

Corrugated bulkhead plating shall be connected to the inner bottom plating by full penetration welds. The plating of the supporting floors shall be connected to the inner bottom by either full penetration or deep penetration welds, in accordance with Fig. 20.7.4.1-2. The thickness and material properties of the supporting floors shall be at least equal to those provided for the corrugation flanges. Moreover, the cut-outs for connections of the inner bottom longitudinals to double bottom floors shall be closed by collar plates. The supporting floors shall be connected to each other by suitable shear plates of the PRS-approved design.

Stool side plating shall align with the corrugation flanges and stool side vertical stiffeners and their brackets in lower stool shall align with the inner bottom longitudinals to provide load transmission between these stiffening members. Stool side plating shall not be knuckled anywhere between the inner bottom plating and the stool top.

20.7.4.2 Bending Capacity and Shear Stress t

Bending capacity shall satisfy the following relationship:

$$10^3 \frac{M}{0.5Z_{le}\sigma_{a,le} + Z_m\sigma_{a,m}} \leq 0.95 \quad (20.7.4.2-1)$$

where:

- M – bending moment [kNm], calculated according to 20.7.3.1;
- Z_{le} – section modulus of one half pitch corrugation, (of width s_1 – see Fig. 20.7.2.3-1), [cm³], at the lower end of corrugations, to be calculated in accordance with 20.7.4.3;
- Z_m – section modulus of one half pitch corrugation, (of width s_1 – see Fig. 20.7.2.3-1) [cm³], at the mid-span of corrugations, to be calculated in accordance with 20.7.4.4;
- $\sigma_{a,le}$ – allowable stress [MPa], as required in 20.7.4.5, for the lower end of corrugations;
- $\sigma_{a,m}$ – allowable stress [MPa], as required in 20.7.4.5, for the mid-span of corrugations.

In no case Z_m shall be taken greater than the lesser of $1.15Z_{le}$ and $1.15Z'_{le}$ for calculation of the bending capacity, Z'_{le} being defined below.

Where shedder plates are fitted which:

- are not knuckled,
- are welded to the corrugations and the top of the lower stool by one side penetration welds or equivalent,
- are fitted with a minimum slope of 45° and their lower edge is in line with the stool side plating,
- have thicknesses not less than 75% of that provided by the corrugation flange,
- have material properties at least equal to those provided by the flanges,

or gusset plates are fitted which:

- are in combination with shedder plates having thickness, material properties and welded connections in accordance with the above requirements,
- have a height not less than half of the flange width,
- are fitted in line with the stool side plating,
- are generally welded to the top of the lower stool by full penetration welds, and to the corrugations and shedder plates by one side penetration welds or equivalent,
- have thickness and material properties at least equal to those provided for the flanges,

the section modulus Z_{le} shall be taken not larger than the value Z'_{le} , determined in accordance with the following formula:

$$Z'_{le} = Z_g + 10^3 \frac{Qh_g - 0.5h_g^2 s_1 p_g}{\sigma_a} \quad [\text{cm}^3] \quad (20.7.4.2-2)$$

where:

- Z_g – section modulus of one half pitch corrugation (of width s_1 – see Fig. 20.7.2.3-1), [cm³], of the corrugations calculated as required in 20.7.4.4, in way of the upper end of shedder or gusset plates, as applicable;
- Q – shear force [kN], calculated according to 20.7.3.2;
- h_g – height [m], of shedder or gusset plates, as applicable (see Figures 20.7.4.2-1 to 20.7.4.2-4);
- s_1 – as in 20.7.2.3;
- p_g – resultant pressure [kPa], as defined in 20.7.2.5, calculated in way of the middle of the shedder or gusset plates, as applicable;
- σ_a – allowable stress [MPa], see sub-chapter 20.7.4.5.

Stresses, τ , are obtained by dividing the shear force Q by the shear area. The shear area shall be reduced in order to account for possible non-perpendicularity between the corrugation webs and flanges. In general, the reduced shear area may be obtained by multiplying the web sectional area by $\sin\phi$ (ϕ being the angle between the web and the flange, as shown in Fig. 20.7.2.3-1).

When calculating the section modulus and the shear area, the net plate thicknesses shall be used.

The section modulus of corrugations shall be calculated on the basis of the requirements specified in 20.7.4.3 and 20.7.4.4.

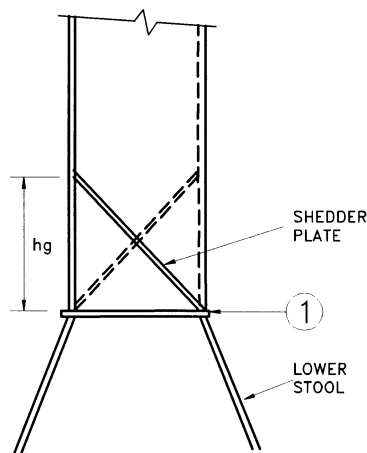

Fig. 20.7.4.2-1.
Symmetric shedder plates

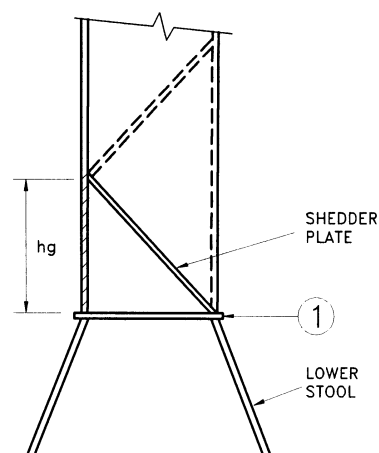

Fig. 20.7.4.2-2.
Asymmetric shedder plates

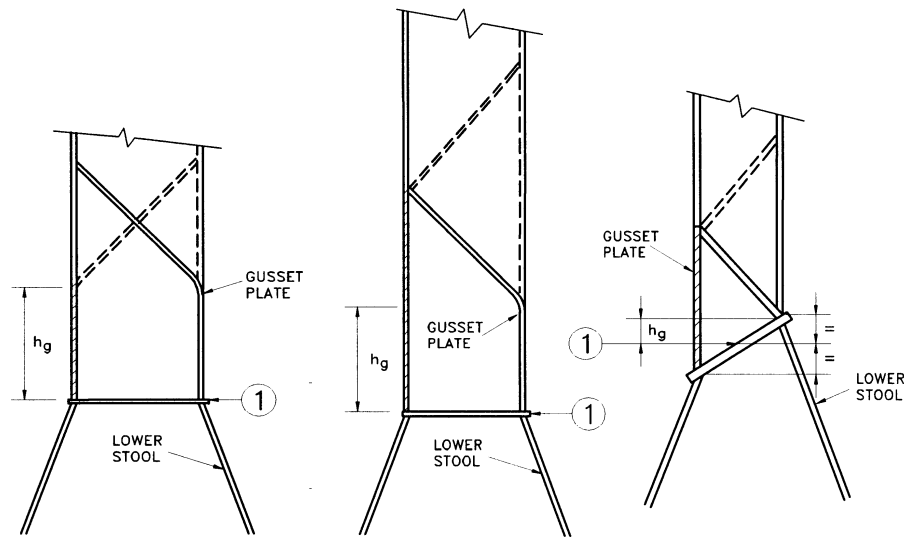

Fig. 20.7.4.2-3

Symmetric gusset/shedder plates

Fig. 20.7.4.2-4.

Asymmetric gusset/shedder plates

20.7.4.3 Section Modulus at the Lower End of Corrugations

The section modulus shall be calculated with the compression flange having an effective flange width, b_{ef} , not larger than as specified in 20.7.4.6.

If the corrugation webs are not supported by local brackets below the stool top (or below the inner bottom) in the lower part, the section modulus of the corrugations shall be calculated considering the corrugation webs 30% effective.

- a) Provided that effective shedder plates, as specified in 20.7.4.2, are fitted (see Figs. 20.7.4.2-1 and 20.7.4.2-2), when calculating the section modulus of corrugations at the lower end (cross-section ○ in the above Figures), the area of flange plates, in cm^2 , may be increased by:

$$2.5a\sqrt{t_f t_{sh}} \text{ (not to be taken greater than } 2.5at_f\text{)}$$

where:

- a – width, [m], of the corrugation flange (see Fig. 20.7.2.3-1);
 t_{sh} – net shedder plate thickness [mm];
 t_f – net flange thickness [mm].

- b) Provided that effective gusset plates, as specified in 20.7.4.2, are fitted (see Figs. 20.7.4.2-3 and 20.7.4.2-4), when calculating the section modulus of corrugations at the lower end (cross-section ○ in the above Figures), the area of flange plates, [cm^2], may be increased by $(7h_g t_f)$, where:

h_g – height of gusset plate [m], see Figs. 20.7.4.2-3 and 20.7.4.2-4, not to be taken greater than:

$$\left(\frac{10}{7} s_{gu} \right)$$

- s_{gu} – width of the gusset plates [m],
 t_f – net flange thickness [mm], based on the as built condition.

- c) If the corrugation webs are welded to a sloping stool top plate which have an angle not less than 45° with the horizontal plane, the section modulus of the corrugations may be calculated considering the corrugation webs fully effective. Where effective gusset plates are fitted, when

calculating the section modulus of corrugations, the area of flange plates may be increased as specified in b) above. No credit can be given where only shedder plates are applied.

For angles less than 45°, the effectiveness of the web may be obtained by linear interpolation between 30% for 0° and 100% for 45°.

20.7.4.4 Section Modulus of Corrugations at Cross-Sections other than the Lower End

The section modulus shall be calculated with the corrugation webs considered effective and the compression flange having an effective flange width, b_{ef} , not larger than as specified in 20.7.4.6.1.

20.7.4.5 Allowable Stress Check

Normal and shear stresses σ and τ shall not exceed the allowable values σ_a and τ_a given by:

$$\sigma_a = R_e \quad (20.7.4.5-1)$$

$$\tau_a = 0.5R_e \quad (20.7.4.5-2)$$

R_e – the minimum upper yield stress [MPa], of the material.

20.7.4.6 Effective Compression Flange Width and Shear Buckling Check

20.7.4.6.1 Effective Width of the Compression Flange of Corrugations

Effective width b_{ef} of the corrugation flange shall be calculated in accordance with the following formula:

$$b_{ef} = C_e a \quad [\text{m}] \quad (20.7.4.6.1)$$

where:

$$C_e = \frac{2.25}{\beta} - \frac{1.25}{\beta^2} \quad \text{for } \beta > 1.25;$$

$$C_e = 1.0 \quad \text{for } \beta \leq 1.25;$$

$$\beta = 10^3 \frac{a}{t_f} \sqrt{\frac{R_e}{E}};$$

t_f – net flange thickness [mm];

a – width [m], of the corrugation flange (see Fig. 20.7.2.3-1);

R_e – minimum upper yield stress [MPa], of the material;

E – modulus of elasticity of the material [MPa], to be assumed equal to $2.06 \cdot 10^5$ for steel.

20.7.4.6.2 Shear

Buckling check shall be performed for the web plates at the corrugation ends.

Shear stress τ shall not exceed the critical value τ_c [MPa], obtained by the following:

$$\tau_c = \tau_E \quad \text{when } \tau_E \leq \frac{\tau_F}{2} \quad (20.7.4.6.1.1-1)$$

$$\tau_c = \tau_E \left(1 - \frac{\tau_F}{4\tau_E} \right) \quad \text{when } \tau_E > \frac{\tau_F}{2} \quad (20.7.4.6.1.1-2)$$

where:

$$\tau_F = \frac{R_e}{\sqrt{3}}$$

R_e – minimum upper yield stress, [MPa], of the material;

$$\tau_E = 0.9k_t E \left(\frac{t}{1000c} \right)^2 \quad [\text{MPa}] \quad (20.7.4.6.1.1-3)$$

k_t , E , t and c are given by:

$$k_t = 6.34,$$

E – modulus of elasticity of material, determined in 20.7.4.6.1;

t – net thickness [mm], of corrugation web;

c – width [m], of corrugation web (see Fig. 20.7.2.3-1).

20.7.4.7 Local Net Plate Thickness

Bulkhead local net plate thickness t shall not be less than:

$$t = 14.9s_w \sqrt{\frac{1.05p}{R_e}} \quad [\text{mm}] \quad (20.7.4.7-1)$$

where:

s_w – plate width, [m], to be taken equal to the width of the corrugation flange or web, whichever is the greater (see Fig. 20.7.2.3-1);

p – resultant pressure [kPa], as specified in 20.7.2.5, at the bottom of each strake of plating; in all cases, the net thickness of the lowest strake shall be determined using the resultant pressure at the top of the lower stool, or at the inner bottom, if no lower stool is fitted or at the top of shedders, if shedder or gusset/shedder plates are fitted;

R_e – minimum upper yield stress [MPa], of the material.

For built-up corrugation bulkheads, when the thicknesses of the flange and web are different, the net thickness of the narrower plating shall be not less than:

$$t_n = 14.9s_n \sqrt{\frac{1.05p}{R_e}} \quad [\text{mm}] \quad (20.7.4.7-2)$$

s_n – being the width, [m], of the narrower plating.

The net thickness of the wider plating shall not be taken less than the maximum of the following values:

$$t_w = 14.9s_w \sqrt{\frac{1.05p}{R_e}} \quad [\text{mm}] \quad (20.7.4.7-3)$$

and

$$t_w = \sqrt{\frac{440s_w^2 1.05p}{R_e} - t_{np}^2} \quad [\text{mm}] \quad (20.7.4.7-4)$$

where $t_{np} \leq$ actual net thickness of the narrower plating and not to be greater than $14.9s_w \sqrt{\frac{1.05p}{R_e}}$.

20.7.5 Local Details

As applicable, the design of local details shall comply with the relevant requirements specified in this Part of the *Rules* for the purpose of transferring the corrugated bulkhead forces and moments to the boundary structures, in particular to the double bottom and cross-deck structures.

In particular, the thickness and stiffening of effective gusset and shedder plates, as defined in 20.7.4.3, shall comply with the requirements specified in sub-chapter 9.4 with the use of the design loads determined according to 20.7.2 and allowable stresses determined in accordance with the requirements of 13.4.2.3 or 13.5.2.1.

Unless otherwise stated, weld connections and materials shall meet the relevant requirements specified in the present Part of the *Rules* (Chapters 2 and 4).

20.7.6 Corrosion Addition and Steel Renewal

Corrosion addition t_s shall be taken equal to 3.5 mm.

Steel renewal is required where the gauged thickness is less than $t_{net} + 0.5$ mm.

Where the gauged thickness is within the range $t_{net} + 0.5$ mm and $t_{net} + 1.0$ mm, coating (applied in accordance with the coating manufacturer's requirements) or annual gauging may be adopted as an alternative to steel renewal.

20.8 Evaluation of Allowable Hold Loading for Bulk Carriers Considering Hold Flooding

20.8.1 Application and Definitions

20.8.1.1 Bulk carriers of $L_0 \geq 150$ m in length and above, with single deck, topside tanks and hopper tanks, and of single side or double side skin¹ construction intended to carry solid bulk cargoes having a density of 1.0 t/m³, or above, contracted for construction on 1 July 2006 or later, shall comply with the following requirements in respect of the flooding of any cargo hold:

- the loading in each hold shall not exceed the allowable hold loading in flooded condition, calculated in accordance with 20.8.4, using the loads as defined in 20.8.2 and the shear capacity of the double bottom as defined in 20.8.3;
- in no case is the allowable hold loading, considering flooding, to be taken greater than the design hold loading in intact condition.

20.8.2 Loading Model

20.8.2.1 General

Loads to be considered as acting on the double bottom are those given by the external sea pressures and the combination of the cargo loads with those induced by the flooding of the hold to which the double bottom belongs.

The most severe combinations of cargo induced loads and flooding loads shall be used, depending on the loading conditions included in the loading manual:

- homogeneous loading conditions;
- non-homogeneous loading conditions;
- packed cargo conditions (such as steel mill products. etc).

For each loading condition, the maximum bulk cargo density to be carried shall be considered in calculating the allowable hold loading limit.

20.8.2.2 Inner Bottom Flooding Head

¹ So arranged that each portion of the longitudinal bulkhead is situated within B/5 or 11.5 m (whichever is less) measured horizontally from the ship's side inwards, perpendicularly to the centre plane, at the level of summer waterline.

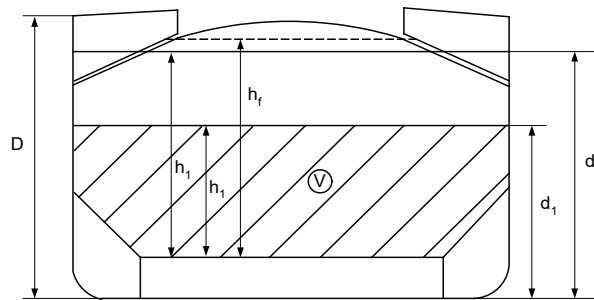

V —volume of cargo

Fig. 20.8.2.2

The flooding head h_f (see Fig. 20.8.2.2) is the distance, in m, measured vertically with the ship in the upright position, from the inner bottom to a level located at a distance d_f in m, from the base plane equal to:

a) in general:

- D for the foremost hold,
- $0.9D$ for the other holds;

b) for ships less than 50,000 tonnes deadweight with Type B freeboard:

- $0.95D$ for the foremost hold,
- $0.85D$ for the other holds,

D being the distance [m], from the base plane to the freeboard deck at side amidships (see Fig. 20.8.2.2).

20.8.3 Shear Capacity of Double Bottom

Shear capacity of the double bottom is defined as the sum of the shear strength at each end of:

- all floors adjacent to both hoppers, less one half of the strength of the two floors adjacent to each stool, or transverse bulkhead if no stool is fitted (see Fig. 20.8.3).
- all double bottom girders adjacent to both stools, or transverse bulkheads if no stool is fitted.

Where in the end holds, girders or floors run out and are not directly attached to the boundary stool or hopper girder, their strength shall be evaluated for the one end only.

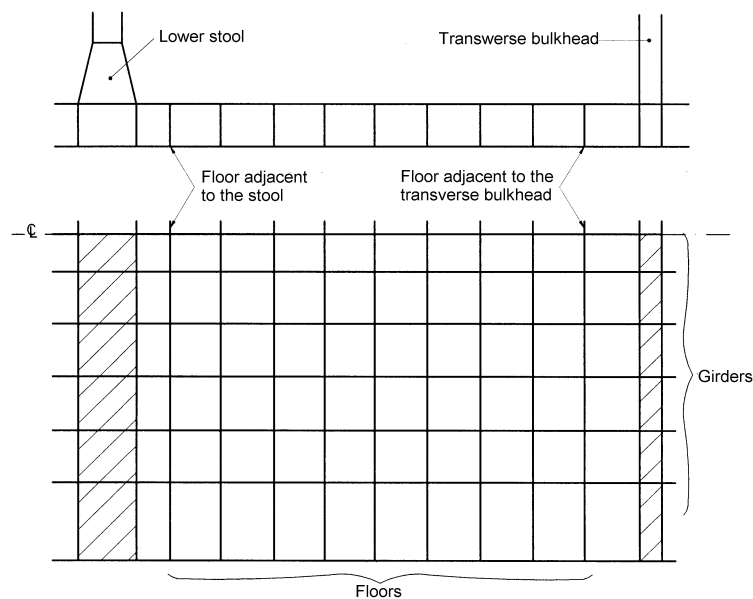

Fig. 20.8.3

Note that the floors and girders to be considered are those inside the hold boundaries formed by the hoppers and stools (or transverse bulkheads if no stool is fitted). The hopper side girders and the floors directly below the connection of the bulkhead stools (or transverse bulkheads if no stool is fitted) to the inner bottom shall not be included.

When the geometry and/or the structural arrangement of the double bottom are such as to make the above assumptions inadequate, the shear capacity of double bottom is subject to PRS consideration in each particular case.

In calculating the shear strength, the net thickness of floors and girders shall be used. The net thickness t_{net} shall be determined in accordance with the following formula:

$$t_{net} = t - 2.5 \quad [\text{mm}] \quad (20.8.3)$$

where:

t – thickness [mm], of floors and girders.

20.8.3.1 Floor Shear Strength

Floor shear strength in way of the floor panel adjacent to hoppers S_{f1} and the floor shear strength in way of the openings in the outmost bay (i.e. that bay which is closer to hopper) S_{f2} are given by the following expressions:

$$S_{f1} = 10^{-3} A_f \frac{\tau_a}{\eta_1} \quad [\text{kN}] \quad (20.8.3.1-1)$$

$$S_{f2} = 10^{-3} A_{f,h} \frac{\tau_a}{\eta_2} \quad [\text{kN}] \quad (20.8.3.1-2)$$

where:

A_f – sectional area [mm²], of the floor panel adjacent to hoppers;

$A_{f,h}$ – net sectional area [mm²], of the floor panels in way of the openings in the outmost bay (i.e. that bay which is closer to hopper);

τ_a – allowable shear stress [MPa], to be taken equal to the lesser of:

$$\tau_a = \frac{162R_e^{0.6}}{(s/t_{net})^{0.8}} \quad \text{and} \quad \frac{R_e}{\sqrt{3}} \quad (20.8.3.1-3)$$

For floors adjacent to the stools or transverse bulkheads, as indicated in Fig. 20.8.3, τ_a may be taken $R_e / \sqrt{3}$.

R_e – minimum upper yield stress [MPa], of the material;

s – spacing of stiffening members [mm], of panel under consideration;

$$\eta_1 = 1.10;$$

$$\eta_2 = 1.20;$$

η_2 may be reduced, upon PRS' agreement, down to 1.10 where appropriate reinforcements are fitted.

20.8.3.2 Girder Shear Strength

The girder shear strength in way of the girder panel adjacent to stools (or transverse bulkheads, if no stool is fitted) S_{g1} and the girder shear strength in way of the largest opening in the outmost bay (i.e. that bay which is closer to stool, or transverse bulkhead, if no stool is fitted) S_{g2} are given by the following expressions:

$$S_{g1} = 10^{-3} A_g \frac{\tau_a}{\eta_1} \quad [\text{kN}] \quad (20.8.3.2-1)$$

$$S_{g2} = 10^{-3} A_{g,h} \frac{\tau_a}{\eta_2} \quad [\text{kN}] \quad (20.8.3.2-2)$$

where:

A_g – minimum sectional area [mm²] of the girder panel adjacent to stools (or transverse bulkheads, if no stool is fitted);

$A_{g,h}$ – net sectional area [mm²] of the girder panel in way of the largest opening in the outmost bay (i.e. that bay which is closer to stool, or transverse bulkhead, if no stool is fitted);

τ_a – allowable shear stress [MPa], determined according to 20.8.3.1;

$$\eta_1 = 1.10;$$

$$\eta_2 = 1.15;$$

η_2 may be reduced, upon PRS' agreement, down to 1.10 where appropriate reinforcements are fitted.

20.8.4 Allowable Hold Loading

The allowable hold loading W shall be determined in accordance with the following formula:

$$W = \rho_c V \frac{1}{F} \quad [\text{t}] \quad (20.8.4-1)$$

where:

$F = 1.1$ in general,

1.05 for steel mill products;

ρ_c – cargo density [t/m³]; for bulk cargoes determined in accordance with 20.8.2.1; for steel products, ρ_c shall be taken as the density of steel;

V – volume [m³], occupied by cargo at a level h_1 (Fig. 20.8.2.2);

$$h_1 = \frac{X}{\rho_c g} \quad (20.8.4-2)$$

X – for bulk cargoes, the lesser of X_1 and X_2 given by the below formula shall be taken:

$$X_1 = \frac{Z + \rho g(E - h_f)}{1 + \frac{\rho}{\rho_c}(\text{perm} - 1)} \quad (20.8.4-3)$$

$$X_2 = Z + \rho h(E - h_f \text{ perm}) \quad (20.8.4-4)$$

X – for steel products, X may be taken as X_1 , using $\text{perm} = 0$;

ρ – sea water density [t/m³];

g = 9.81 m/s², gravity acceleration;

E – ship immersion, [m], for flooded hold condition = $d_f - 0.1D$;

d_f, D – as in 20.8.2.2;

h_f – flooding head [m], determined in accordance with 20.8.2.2;

perm – cargo permeability (i.e. the ratio between the voids within the cargo mass and the volume occupied by the cargo); it need not be taken greater than 0.3;

Z – the lesser of Z_1 and Z_2 given by:

$$Z_1 = \frac{C_h}{A_{DB,h}} \quad (20.8.4-5)$$

$$Z_2 = \frac{C_e}{A_{DB,e}} \quad (20.8.4-6)$$

C_h – shear capacity of the double bottom [kN], calculated in accordance with 20.8.3, considering, for each floor, the lesser of the shear strengths S_{f1} and S_{f2} (see 20.8.3.1) and, for each girder, the lesser of the shear strengths S_{g1} and S_{g2} (see 20.8.3.2);

C_e – shear capacity of the double bottom [kN], as determined in 20.8.3, considering, for each floor, the shear strength S_{f1} (see 20.8.3.1) and, for each girder, the lesser of the shear strengths S_{g1} and S_{g2} (see 20.8.3.2);

$$A_{DB,h} = \sum_{i=1}^{j=n} S_i B_{DB,i} \quad (20.8.4-7)$$

$$A_{DB,e} = \sum_{i=1}^{j=n} S_i (B_{DB} - S_i) \quad (20.8.4-8)$$

n – number of floors between stools (or transverse bulkheads, if no stool is fitted);

S_i – space of i^{th} -floor [m];

$B_{DB,i}$ = $B_{DB} - S_1$ for floors whose shear strength is given by S_{f1} (see 20.8.3.1);

$B_{DB,i}$ = $B_{DB,h}$ for floors whose shear strength is given by S_{f2} (see 20.8.3.1);

B_{DB} – breadth of double bottom, [m], between hoppers (see Fig. 20.8.4);

$B_{DB,h}$ – distance, [m], between the two considered openings (see Fig. 20.8.4);

S_1 – spacing, [m], of double bottom longitudinals adjacent to hoppers.

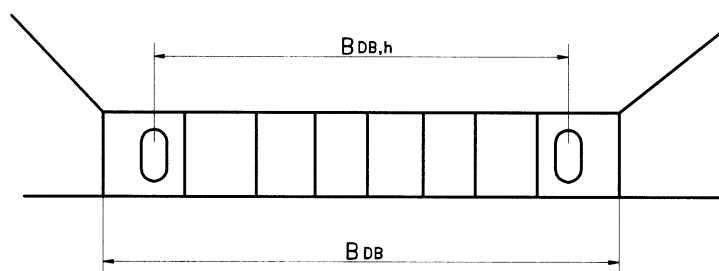

Fig. 20.8.4

20.9 Design Loading Conditions and Corresponding Descriptive Information

20.9.1 Application

20.9.1.1 The present requirements apply to bulk carriers specified in sub-chapter 20.1.2 of the length $L_0 \geq 150$ m:

20.9.1.2 The loading conditions specified in sub-chapter 20.9.3 shall be used for the checking of *Rules* criteria regarding longitudinal strength¹, local strength, capacity and disposition of ballast tanks and stability. The loading conditions specified in sub-chapter 20.9.4 shall be used for the checking of *Rules* criteria regarding local strength.

20.9.1.3 For the purpose of applying the conditions specified in the present sub-chapter, maximum draught shall be taken as moulded summer load line draught.

20.9.1.4 The present requirements are not intended to prevent any other loading conditions to be included in the loading manual for which calculations shall be submitted as required by Chapter 15, nor are they intended to replace in any way the required loading manual/instrument.

20.9.1.5 A bulk carrier may in actual operation be loaded differently from the design loading conditions specified in the loading manual, provided limitations for longitudinal and local strength as defined in the loading manual and loading instrument on board and applicable stability requirements are not exceeded.

20.9.2 Additional Descriptive Information

20.9.2.1 For the purpose of determining detailed limitations of service resulting from the design loading conditions, the following descriptive information is entered in the *Certificate of Class*:

- {**maximum allowable mass density of cargo x.y [t/m³]**} – for the maximum allowable mass density of cargo less than 3.0 t/m³;
- „**no MP**”, where a ship has not been designed for cargo handling operations in several ports in accordance with the requirements specified in 20.9.4.3;
- {**cargo holds a, b, may be empty**} – allowable combinations of empty holds are specified.

20.9.2.2 Additional Notations and Annotations

The following additional notations and annotations shall be provided in the *Certificate of Class* giving detailed description of limitations to be observed during operation as a consequence of the design loading condition applied during the design in the following cases:

- .1 additional notations:

¹ As required by Chapter 15 and sub-chapter 20.6.

- {**maximum cargo density [t/m³]**} for notations **BC-A** and **BC-B** if the maximum cargo density is less than 3.0 tonnes/m³;
 - {**no MP**} for all notations when the vessel has not been designed for loading and unloading in multiple ports in accordance with the conditions specified in 20.9.4.3.
- .2 annotations:
- {**allowed combination of specified empty holds**} for notation **BC-A**.

20.9.3 Design Loading Conditions (General Requirements)

20.9.3.1 Ballast Conditions

20.9.3.1.1 Ballast Tank Capacity and Disposition

All bulk carriers shall have ballast tanks of sufficient capacity and so disposed as to at least fulfil the following requirements.

Normal Ballast Condition

Normal ballast condition for the purpose of these requirements is a ballast (no cargo) condition where:

- .1 the ballast tanks may be full, partially full or empty. Where partially full option is exercised, the conditions specified in paragraph 15.4.1.1 shall be complied with;
- .2 any cargo hold or holds adapted for the carriage of water ballast at sea shall be empty;
- .3 the propeller shall be fully immersed, and
- .4 the trim shall be by the stern and shall not exceed $0.015L_{pp}$, where L_{pp} is the length between perpendiculars of the ship.

In the assessment of the propeller immersion and trim, the draughts at the forward and after perpendiculars may be used.

Heavy Ballast Condition

Heavy ballast condition for the purpose of these requirements is a ballast (no cargo) condition where:

- .1 the ballast tanks may be full, partially full or empty. Where partially full option is exercised, the conditions specified in paragraph 15.4.1.1 shall be complied with;
- .2 at least one cargo hold adapted for the carriage of water ballast at sea, where required or provided, shall be full;
- .3 the propeller immersion I/D shall be at least 60% where:
 I = the distance from propeller centerline to the waterline
 D = propeller diameter, and
- .4 the trim shall be by the stern and shall not exceed $0.015L_{pp}$, where L_{pp} is the length between perpendiculars of the ship;
- .5 the moulded forward draught in the heavy ballast condition shall not be less than the smaller of $0.03L_0$ or 8 m.

20.9.3.1.2 Strength Requirements

All bulk carriers shall meet the following strength requirements:

Normal Ballast Condition

- .1 the structure of bottom forward shall be strengthened in accordance with the PRS Rules against slamming for the condition at the lightest forward draught,

- .2 the longitudinal strength requirements shall be met for the condition specified in paragraph 20.9.3.1.1 for normal ballast, and
- .3 in addition, the longitudinal strength requirements shall be met with all ballast tanks 100 % full.

Heavy Ballast Condition

- .1 the longitudinal strength requirements shall be met for the condition specified in paragraph 20.9.3.1.1 for heavy ballast,
- .2 in addition, the longitudinal strength requirements shall be met under a condition with all ballast tanks 100 % full and one cargo hold adapted and designated for the carriage of water ballast at sea, where provided, 100 % full, and
- .3 where more than one hold is adapted and designated for the carriage of water ballast at sea, it will not be required that two or more holds be assumed 100 % full simultaneously in the longitudinal strength assessment, unless such conditions are expected in the heavy ballast condition. Unless each hold is individually investigated, the designated heavy ballast hold and any/all restrictions for the use of other ballast hold(s) shall be indicated in the loading manual.

20.9.3.2 Departure and Arrival Conditions

Unless otherwise specified, each of the design loading conditions specified in paragraphs 20.9.3.1 to 20.9.3.4 shall be investigated for the arrival and departure conditions as defined below.

Departure condition: with bunker tanks not less than 95 % full and other consumables 100 %.

Arrival condition: with 10% of consumables.

20.9.4 Design Loading Conditions (for local strength)

20.9.4.1 Definitions

The maximum allowable or minimum required cargo mass in a cargo hold, or in two adjacently loaded holds, is related to the net load on the double bottom. The net load on the double bottom is a function of draft, cargo mass in the cargo hold, as well as the mass of fuel oil and ballast water contained in double bottom tanks.

The following definitions apply:

- M_H – the actual cargo mass in a cargo hold corresponding to a homogeneously loaded condition at maximum draught.
- M_{Full} – the cargo mass in a cargo hold corresponding to cargo with virtual density (homogeneous mass/hold cubic capacity, minimum 1.0 tonne/m³) filled to the top of the hatch coaming. M_{Full} shall in no case be less than M_H .
- M_{HD} – the maximum cargo mass allowed to be carried in a cargo hold in accordance with the design loading condition(s) with specified holds empty at maximum draft.

20.9.4.2 General Conditions Applicable for All Notations

20.9.4.2.1 Any cargo hold shall be capable of carrying M_{Full} with fuel oil tanks in double bottom in way of the cargo hold, if any, being 100% full and ballast water tanks in the double bottom in way of the cargo hold being empty, at maximum draught.

20.9.4.2.2 Any cargo hold shall be capable of carrying minimum 50% of M_H , with all double bottom tanks in way of the cargo hold being empty, at maximum draught.

20.9.4.2.3 Any cargo hold shall be capable of being empty, with all double bottom tanks in way of the cargo hold being empty, at the deepest ballast draught.

20.9.4.3 Conditions Applicable to all Ships

20.9.4.3.1 Any cargo hold shall be capable of carrying M_{Full} with fuel oil tanks in double bottom in way of the cargo hold, if any, being 100% full and ballast water tanks in the double bottom in way of the cargo hold being empty, at 67% of maximum draught.

20.9.4.3.2 Any cargo hold shall be capable of being empty with all double bottom tanks in way of the cargo hold being empty, at 83% of maximum draught.

20.9.4.3.3 Any two adjacent cargo holds shall be capable of carrying M_{Full} with fuel oil tanks in double bottom in way of the cargo hold, if any, being 100% full and ballast water tanks in the double bottom in way of the cargo hold being empty, at 67% of the maximum draught. This requirement for the mass of cargo and fuel oil in double bottom tanks in way of the cargo hold applies also to the condition where the adjacent hold is filled with ballast, if applicable.

20.9.4.3.4 Any two adjacent cargo holds shall be capable of being empty with all double bottom tanks in way of the cargo hold being empty, at 75% of maximum draught.

20.9.4.4 Additional Conditions for Cargo Holds

20.9.4.4.1 Cargo holds, which are intended to be empty at maximum draught, shall be capable of being empty with all double bottom tanks in way of the cargo hold also being empty.

20.9.4.4.2 Cargo holds, which are intended to be loaded with high density cargo, shall be capable of carrying M_{HD} plus 10% of M_H , with fuel oil tanks in the double bottom in way of the cargo hold, if any, being 100% full and ballast water tanks in the double bottom being empty in way of the cargo hold, at maximum draught. In operation the maximum allowable cargo mass shall be limited to M_{HD} .

20.9.4.4.3 Any two adjacent cargo holds which in accordance with the design loading condition may be loaded with the next holds being empty, shall be capable of carrying 10% of M_H in each hold in addition to the maximum cargo load in accordance with that design loading condition, with fuel oil tanks in the double bottom in way of the cargo hold, if any, being 100% full and ballast water tanks in the double bottom in way of the cargo hold being empty, at maximum draught.

In operation the maximum allowable mass shall be limited to the maximum cargo load in accordance with the design loading conditions.

20.9.4.5 Additional Conditions Applicable for Ballast Hold(s) Only

20.9.4.5.1 Cargo holds, which are designed as ballast water holds, shall be capable of being 100% full of ballast water including hatchways, with all double bottom tanks in way of the cargo hold being 100% full, at any heavy ballast draught. For ballast holds adjacent to topside wing, hopper and double bottom tanks, it shall be strengthwise acceptable that the ballast holds are filled when the topside wing, hopper and double bottom tanks are empty.

20.9.4.6 Additional Conditions Applicable During Loading and Unloading in Harbour Only

20.9.4.6.1 Any single cargo hold shall be capable of holding the maximum allowable sea-going mass at 67% of maximum draught, in harbour condition.

20.9.4.6.2 Any two adjacent cargo holds shall be capable of carrying M_{Full} , with fuel oil tanks in the double bottom in way of the cargo hold, if any, being 100% full and ballast water tanks in the double bottom in way of the cargo hold being empty, at 67% of maximum draught, in harbour condition.

20.9.4.6.3 At reduced draught during loading and unloading in harbour, the maximum allowable mass in a cargo hold may be increased by 15% of the maximum mass allowed at the maximum draught in sea-going condition, but shall not exceed the mass allowed at maximum draught in the sea-going condition. The minimum required mass may be reduced by the same amount.

20.9.4.7 Hold Mass Curves

Based on the design loading criteria for local strength, as specified in paragraphs 20.9.4.2 to 20.9.4.6 (except paragraph 20.9.4.5.1) above, hold mass curves shall be included in the loading manual and the loading instrument, showing maximum allowable and minimum required mass as a function of draught, in sea-going condition, as well as during loading and unloading in harbour (see *Publication 16/P – Loading Guidance Information*).

At draughts other than those specified in the design loading conditions above, the maximum allowable and minimum required mass shall be adjusted for the change in buoyancy acting on the bottom. Change in buoyancy shall be calculated using water plane area at each draught.

Hold mass curves for each single hold, as well as for any two adjacent holds, shall be included.

20.10 Requirements for Forecastle

20.10.1 Application and Definitions

All ships, ore carriers and combination carriers shall be fitted with an enclosed forecastle on the freeboard deck. The required dimensions of the forecastle are defined in sub-chapter 20.10.2.

Structural arrangements and scantlings of the forecastle shall comply with the requirements specified in Chapter 10.

20.10.2 Dimensions

Forecastle shall be located on the freeboard deck with its aft bulkhead fitted in way or aft of the forward bulkhead of the foremost hold, as shown in Fig. 20.10.2.

However, if this requirement hinders hatch cover operation, the aft bulkhead of the forecastle may be fitted forward of the forward bulkhead of the foremost cargo hold, provided the forecastle length is not less than $0.07L$ of the ship's length abaft the forward perpendicular.

Forecastle height, H_F , above the main deck shall be not less than:

- the standard height of a superstructure as specified in the *International Convention on Load Lines, 1966* and its *Protocol of 1988*, or
- $H_C + 0.5$ m, where H_C is the height of the forward transverse hatch coaming of hold No. 1,

whichever is the greater.

All points of the aft edge of the forecastle deck shall be located at a distance l_F :

$$l_F \leq 5\sqrt{H_F - H_C}$$

from the hatch coaming plate in order to apply the reduced loading to the No.1 forward transverse hatch coaming and No.1 hatch cover in accordance with the requirements specified in paragraphs 12.3.4.1 and 12.3.5.2, respectively, *Part III – Hull Equipment*.

A breakwater shall not be fitted on the forecastle deck for the purpose of protecting the hatch coaming or hatch covers. If fitted for other purposes, it shall be located such that its upper edge at centre line is not less than $H_B/\tan 20^\circ$ forward of the aft edge of the forecastle deck, where H_B is the height of the breakwater above the forecastle (see Fig. 20.10.2).

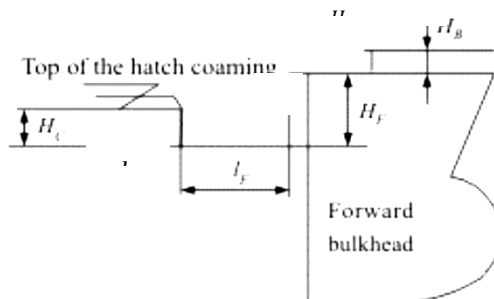

Fig. 20.10.2

20.11 Requirements for Ships with Double-side Skin Construction

20.11.1 Application

The requirements specified in sub-chapter 20.11 are consistent with the requirements of SOLAS-XII/6 and apply to bulk carriers with double-side skin-

20.11.2 Structure and Dimensions

20.11.2.1 Primary stiffening structures of the double-side skin shall not be placed inside the cargo hold space.

20.11.2.2 The distance between the outer shell and the inner shell at any transverse section shall not be less than 1,000 mm measured perpendicular to the side shell (see A in Fig. 20.11.2.2) and shall be maintained throughout the whole double-side skin construction, i.e. from inner bottom to main deck.

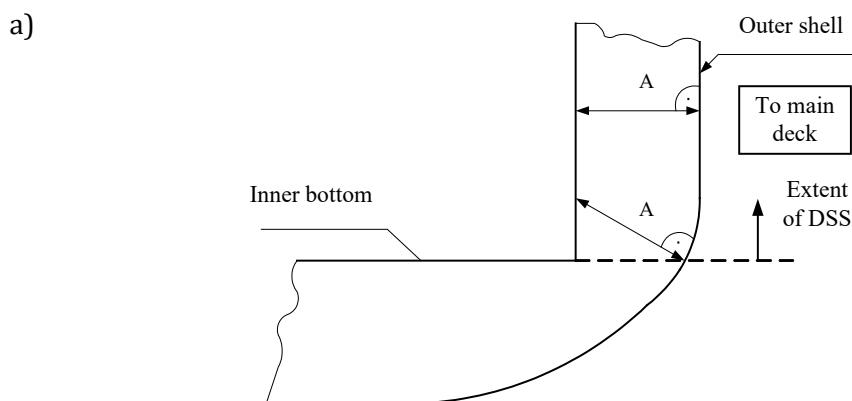

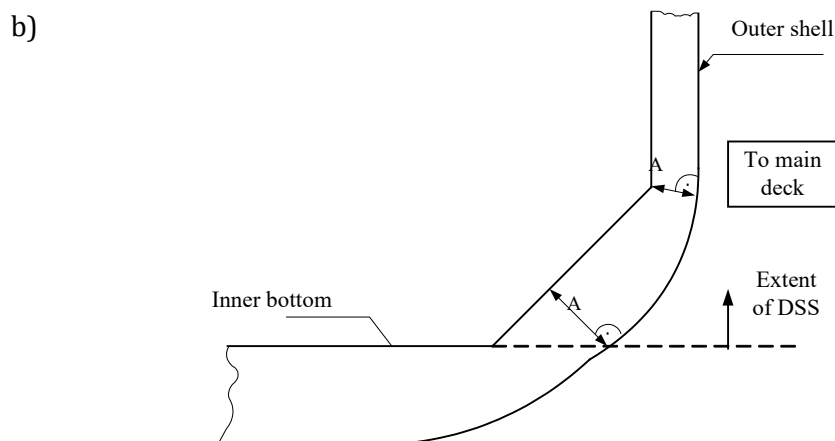

Fig. 20.11.2.2. Interpretation of the distance between outer and inner shell

20.11.2.3 Double-side skin construction shall be such as to allow access for inspection as provided in *SOLAS II-1/3-6* and the requirements specified in .1 to .3:

- .1 the minimum width of the clear passage through the double-side skin space in way of obstructions such as piping or vertical ladders shall not be less than 600 mm;
- .2 where the inner and/or outer skins are transversely framed, the minimum clearance between the inner surfaces of the frames shall not be less than 600 mm;
- .3 where the inner and outer skins are longitudinally framed, the minimum clearance between the inner surfaces of the frames shall not be less than 800 mm. Outside the parallel part of the cargo hold length, this clearance may be reduced where necessitated by the structural configuration, but, in no case, shall be less than 600 mm.

The minimum clearances, referred in .1 to .3, shall be the shortest distance measured between the assumed lines connecting the inner surfaces of the frames on the inner and outer skins.

The above clearances need not be maintained in way of cross-ties, upper and -lower end brackets of transverse framing or end brackets of longitudinal framing.

20.11.3 Corrosion Protection and Use of Double-side Skin Spaces

20.11.3.1 All dedicated seawater ballast tanks arranged in bulk carriers and double-side skin spaces arranged in bulk carriers of 150 m in length and upwards shall be coated during construction in accordance with the requirements specified in *SOLAS II-1*, Regulation 3-2 (detailed requirements are specified in IMO Resolution MSC.215(82) as amended by MSC.341(91)) and the requirements specified in *Publication 55/P – Survey of Corrosion Protection and Anti-fouling Systems* (see also 2.4.1 and 2.4.2).

20.11.3.2 The double-side skin spaces, with the exception of top-side wing tanks, if fitted, shall not be used for the carriage of cargo.

20.12 Requirements for Cargo Area Structure of Hull

20.12.1 Application

The requirements specified in sub-chapter 20.12 apply to bulk carriers of 150 m in length and upwards, carrying solid bulk cargoes having a density of 1.0 t/m³ and above. These requirements are conformant to those specified in *SOLAS XII/6*.

20.12.2 Hull Structure in Cargo Area

20.12.2.1 Effective continuity between the side shell structure and the rest of the hull structure shall be ensured.

20.12.2.2 The structure of cargo holds shall be such that all contemplated cargoes can be loaded and discharged by standard loading/discharge equipment and procedures without damage which may compromise the safety of the structure.

It can be assumed that a ship with **CG** in the symbol of class and fulfilling the requirements specified in sub-chapter 26.4 complies with the requirements listed above.

The protection of hatchways and coamings from grab wire damage is required by fitting protection bars (e.g. half-round bar) on the hatch-side girder in way of deck, hatch-end beams and the upper portion of hatch coamings.

20.12.2.3 The hull structure in the cargo area shall be such that a single failure of one stiffener of plating will not cause immediate damage to other structural members which may lead to complete collapse of stiffened panels (see also 20.12.2.4 to 20.12.2.6). The meaning of the terms used in this requirement is explained below.

Cargo area includes hatchway coamings, top-side tanks, side shells, longitudinal bulkheads of double-side skin construction, bilge hopper tanks and double bottom, but excludes hatchway covers.

Stiffening structural member means a stiffener (rolled or prefabricated) attached to a structural plating panel.

Structural members of a cargo hold are the hatchway coamings, transverse bulkheads, panel plates of the top-side tanks and bilge hopper tanks facing, inner bottom, side shell of single-side skin construction or longitudinal bulkhead of double-side skin construction.

Single failure of one stiffening structural member means localised mechanical damage such as local permanent deformation, cracking or weld failure that might result from accidental damage within the cargo hold.

20.12.2.4 The design considerations for paragraph 20.12.2.3 shall be such that a single localised damage, which is of a size that is likely to be detected, shall not lead to complete collapse of the stiffened panel under a load equal to the maximum allowable design still water plus 80% of the maximum allowable lifetime dynamic load, i.e. of the values exceeded with the probability of 10^{-8} .

20.12.2.5 If the damage is a crack or welding damage, immediate fracture propagation shall be avoided. This shall be achieved by appropriate design and selection of materials.

It can be assumed that the conditions listed above will be met by bulk carriers with single side skin construction if the following parts of hull structure shall not be of lower steel grade than D/DH:

- a) lower brackets of side frames;
- b) side shell plate between two points located to 0.125l above and 0.125l below the intersection of side shell and bilge hopper sloping plate (see Fig. 20.12.2.5).

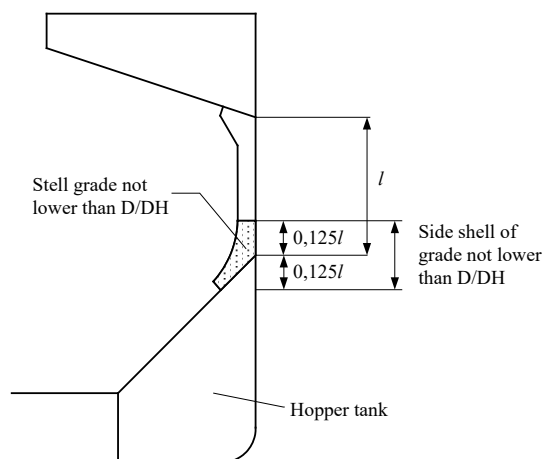

Fig. 20.12.2.5. Part of hull structure where steel grade not lower than D/DH is required

20.12.2.6 The assumption can be accepted that complete collapse of stiffened panels (see 20.12.2.3 and 20.12.2.4) will not occur if their stiffeners comply with the following condition with respect to lateral buckling:

$$\sigma_c \geq 1.27\sigma_r \quad (20.12.2.6)$$

where:

- σ_c – critical stress calculated in accordance with 13.3.2.2 for ideal elastic buckling stress σ_E value calculated in accordance with 13.5.3.2;
- σ_r – compressive stress at neutral axis of the stiffener, calculated in accordance with 13.3.2.7 or while performing zone strength analysis.

The requirements given above are applicable, in particular, to the following areas:

- hatchway coamings;
- inner bottom;
- sloped stiffened panel of topside tanks and hopper tanks;
- inner side (in double-side skin bulk carriers);
- top stool and bottom stool of transverse bulkhead;
- stiffened transverse bulkhead (if any);
- side shell (in single-side skin bulk carriers).

21 TANKERS

21.1 General

21.1.1 Application

21.1.1.1 For double hull oil tankers of 150 in length and above, the requirements of Common Structural Rules (CSR) shall apply in lieu of the requirements specified in sub-chapters 21.2 and 21.3.

The requirements of the present Chapter apply to the remaining ships intended for the carriage of liquid bulk cargoes.

The requirements specified below shall be regarded as supplementary to the basic requirements specified in Chapters 1÷17.

21.1.1.2 The requirements specified in the present Chapter apply also, within appropriate scope, to ships for alternate carriage of liquid cargo in bulk and dry bulk cargoes. These ships shall also comply with the requirements of Chapter 20.

21.1.2 Structural Arrangement

21.1.2.1 A basic type of oil tanker is a sea-going self-propelled ship having integral tanks and intended primarily to carry oil in bulk.

It is, generally, a single deck ship with the machinery space aft, transverse bulkheads, double hull construction, double bottom and one or more longitudinal bulkheads. The hull in way of cargo tanks is longitudinally stiffened.

Alternative structural arrangements – e.g. single hull construction (ships constructed before the entry into force of *MARPOL 73/78*) or mid-deck designs are also applied.

Typical midship sections of oil tankers are given in Fig. 21.1.2.1.

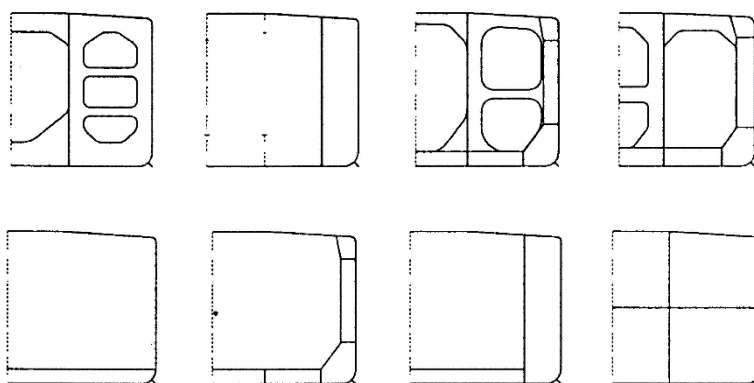

Fig. 21.1.2.1. Typical midship sections of oil tankers

21.1.2.2 Other structural arrangements may be applied in tankers intended for the carriage of liquid cargoes other than crude oil and oil products if they meet the appropriate requirements and are considered equivalent in respect of the hull strength.

21.1.2.3 A basic type of chemical tanker is a sea-going self-propelled ship having integral tanks, intended primarily to carry chemicals in bulk, of single or double hull construction. Alternative structural arrangements are also applied.

Typical midship sections of chemical tankers are shown in Fig. 21.1.2.3.

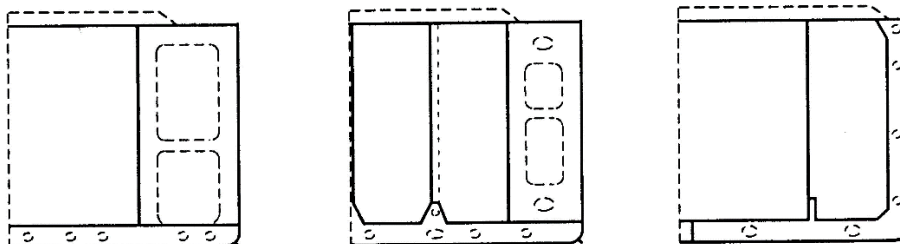

Fig. 21.1.2.3. Typical midship sections of chemical tankers

21.1.3 Classification

Ships complying with the requirements specified in this Chapter (or applicable requirements given in CSR) may be affixed with the following additional marks in the symbol of class:

- CRUDE OIL TANKER** – for crude oil carriers,
- PRODUCT CARRIER A** or
PRODUCT CARRIER B – oil tankers other than crude oil carriers,
- TANKER FOR ...** – for tankers other than crude oil carriers, oil tankers, chemical or gas carriers.

The requirements, which the ships shall fulfil to be affixed with additional marks in the symbol of class: **CHEMICAL TANKER** – chemical carriers, or **LIQUEFIED GAS TANKER** – gas carriers are specified in paragraphs 1.1.6 and 1.1.7, *Part I – Classification Regulations*.

21.1.4 Documentation

21.1.4.1 Technical documentation, specified in 1.4.2, shall be submitted to PRS for consideration and approval.

21.2 General Arrangement

21.2.1 Ship Arrangement

The arrangement of ship spaces shall comply with the requirements specified in the present sub-chapter and the applicable requirements specified in *Part III – Hull Equipment*, *Part IV – Stability and Subdivision*, *Part V – Fire Protection* and in *Part IX – Environmental Protection* of the *Rules for Statutory Survey of Sea-going Ships*.

On oil and chemical tankers, carrying liquid cargoes having a flashpoint not exceeding 60°C and/or toxic liquid cargoes¹, fuel tanks located with a common boundary to cargo or slop tanks shall not be situated within nor extend partly into the cargo tank block. Such tanks may, however, be situated aft and/or forward of the cargo tank block. They may be accepted when located as independent tanks on open deck in the cargo area subject to spill and fire safety considerations.

The arrangement of independent fuel tanks and associated fuel piping systems, including the pumps, can be as for fuel tanks and associated fuel piping systems located in the machinery spaces. For electrical equipment, requirements to hazardous area classification must however be met.

¹ For the purpose of these requirements, toxic liquid cargoes include those for which toxic vapour detection is specified in column “k” of the table of chapter 17 of the IBC Code.

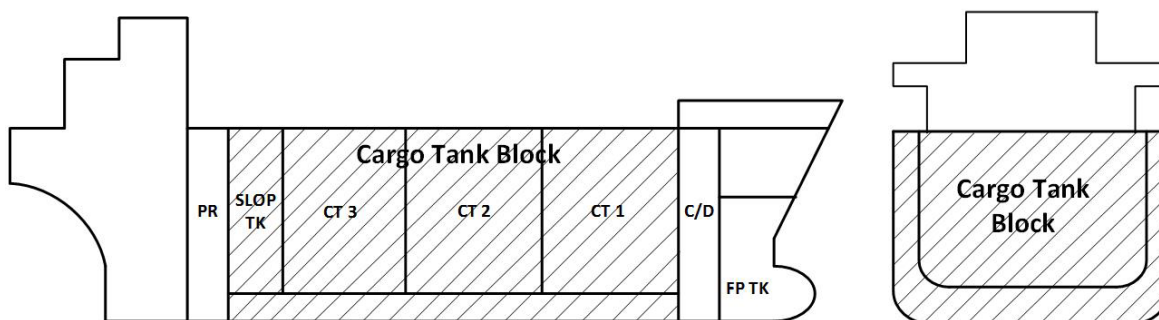

Cargo tank block is the part of the ship extending from the aft bulkhead of the aftmost cargo or slop tank to the forward bulkhead of the forward most cargo or slop tank, extending to the full depth and beam of the ship, but not including the area above the deck of the cargo or slop tank.

Irrespective of the requirements of sub-chapter 21.2.4, cargo, slop and oil fuel tanks in oil tankers, situated within cargo area, shall be arranged so that the requirements concerning accidental oil outflow, specified in Regulation 23 of Annex I to *MARPOL Convention 73/78*, are complied with.

When calculating the mean oil outflow parameter, the assumptions and requirements, specified in regulations 23.4 ÷ 23.11, shall apply. When calculating the cargo level after damage in accordance with Regulation 23.7.3.2, the normal overpressure p is to be taken as 5 kPa if any inert gas system is fitted; the overpressure may be taken as 0 if an inert gas system is not fitted.

21.2.2 Protective Compartments

21.2.2.1 The requirements specified in the present sub-chapter apply to oil tankers of 600 tons deadweight and above.

21.2.2.2 The oil tankers of 5,000 tons deadweight and above shall have the entire cargo tank length protected by ballast tanks or spaces other than cargo and fuel oil tanks, as follows:

- .1 Wing tanks or spaces. They shall extend either for the full depth of the ship's side or from the top of the double bottom to the uppermost deck, disregarding a rounded gunwale, where fitted. They shall be arranged such that the cargo tanks are located inboard of the moulded line of the side shell plating, nowhere less than the distance w which (see Fig. 21.2.2.2) is measured at any cross-section at right angles to the side shell, as specified below:

$$w = 0.5 + \frac{DWT}{20.000} \quad [\text{m}] \quad (21.2.2.2-1)$$

or $w = 2.0$ m, whichever is the lesser.

The minimum value of $w = 1.0$ m.

- .2 Double bottom tanks or spaces. At any cross-section the depth of each double bottom tank or space shall be such that the distance h between the bottom of the cargo tanks and the moulded line of the bottom shell plating measured at right angles to the bottom shell plating (see Fig. 21.2.2.2) is not less than that specified below:

$$h = \frac{B}{15} \quad [\text{m}] \quad (21.2.2.2-2)$$

or $h = 2.0$ m, whichever is the lesser.

The minimum value of $h = 1.0$ m.

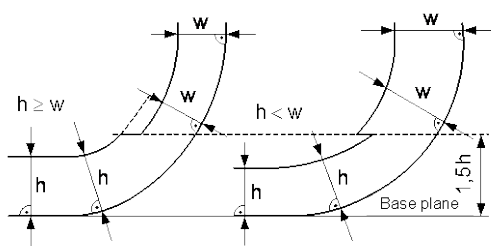

Fig. 21.2.2.2

21.2.2.3 On oil tankers of 5,000 tons deadweight and above, within turn of the bilge area or at locations without a clearly defined turn of bilge, where the distances w and h are different, the distance w shall have preference at levels exceeding $1.5h$ above the base plane – see Fig. 21.2.2.2.

This requirement is applicable throughout the entire tank length.

21.2.2.4 On crude oil carriers of 20,000 tons deadweight and above and product carriers of 30,000 tons deadweight and above, the aggregate capacity of wing tanks, double bottom tanks, forepeak and afterpeak tanks shall not be less than the capacity of segregated ballast tanks necessary to meet the requirements specified in 21.2.3. Wing tanks or spaces and double bottom tanks used to meet the requirements specified in 21.2.3 shall be located as uniformly as practicable along the cargo tank length. Additional segregated ballast capacity provided for reducing longitudinal hull girder bending stress, trim, etc. may be located anywhere within the ship.

21.2.2.5 Suction wells in cargo tanks may protrude into the double bottom below the boundary line defined by the distance h , provided that such wells are as small as practicable and the distance between the well bottom and bottom shell plating is not less than $0.5h$.

Additionally, the size of suction wells shall be appropriate to the size of the suction pipe and area covered.

The above requirements apply also to valves or other appliances cutting off the pipelines connected to the suction well.

21.2.2.6 Double bottom tanks or spaces, as required in 21.2.2.2, may be dispensed with, provided that the design of the tanker is such that the cargo and vapours pressure acting on the bottom shell plating forming a single boundary between the cargo and the sea does not exceed the external hydrostatic water pressure, expressed by the following formula:

$$fh_c p_c g + 100\delta_p \leq d_n p_s g \quad (21.2.2.6)$$

h_c – height of cargo in contact with the bottom shell plating, [m];

p_c – maximum cargo density, [t/m³];

d_n – minimum operating draught under any expected loading condition, [m];

p_s – density of sea water, [t/m³];

δ_p – maximum set pressure of the pressure/vacuum valve provided for the cargo tank, [bars];

f – safety factor = 1.1;

g – acceleration of gravity, [m/s²].

21.2.2.7 Any horizontal partition necessary to fulfill the requirements specified in 21.2.2.6 shall be located at a height of not less than $B/6$ or 6 m, whichever is the lesser, but not more than $0.6H$ above the base plane. H is the moulded depth amidships.

21.2.2.8 For the space arrangement in accordance with the requirements specified in 21.2.2.6, the location of wing tanks or spaces shall be in accordance with the requirements set forth in 21.2.2.2.1, except that, below a level $1.5 h$ above the base plane where h is as defined in 21.2.2.2.2, the cargo tank boundary line may be vertical down to the bottom plating, as shown in Fig. 21.2.2.8.

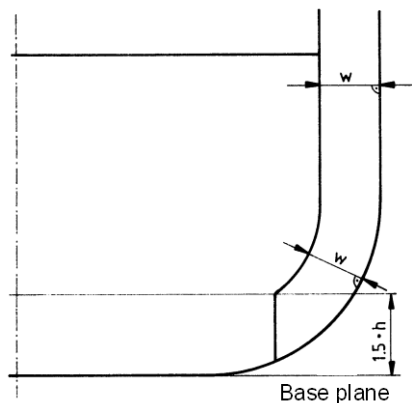

Fig. 21.2.2.8

21.2.2.9 Other methods of design and construction of oil tankers may be also accepted as alternatives to the requirements, specified in 21.2.2.2 to 21.2.2.5, provided that such methods ensure at least the same level of protection against oil pollution in the event of damage/collision or stranding.

In the evaluation of alternative designs, recommendations given in IMO Res. MEPC.110(49), Res. MEPC.64(36) shall be taken into account.

21.2.2.10 Oil tankers of less than 5,000 tons deadweight shall comply with the following requirements:

- they shall be fitted with at least double bottom tanks or spaces having such a depth that the distance h , determined in accordance with 21.2.2.2.2, complies with the following: $h = B/15$, [m], with a minimum value of $h = 0.76$ m.

In the turn of the bilge area and at locations without a clearly defined turn of the bilge, the cargo tank boundary line shall run parallel to the line of the midship flat bottom as shown in Fig. 21.2.2.10;

- they shall be provided with cargo tanks so arranged that the capacity of each cargo tank does not exceed 700 m^3 unless wing tanks or spaces are arranged in accordance with paragraph 21.2.2.2.1 complying with the following:

$$w = 0.4 + \frac{2.4DWT}{20.000} \text{ [m]}, \text{ and } w \text{ is not less than } 0.76 \text{ m.}$$

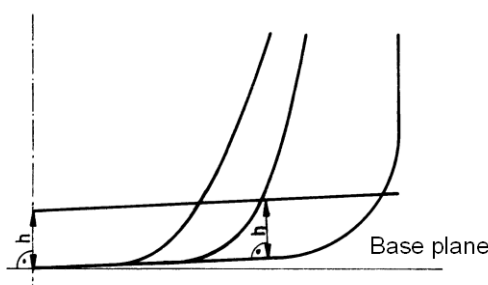

Fig. 21.2.2.10

21.2.2.11 No cargo tanks shall be provided in front of the collision bulkhead.

21.2.3 Segregated Ballast Tanks

21.2.3.1 The requirements specified in the present sub-chapter apply to crude oil tankers of 20,000 tons deadweight and above and product carriers of 30,000 tons deadweight and above.

21.2.3.2 Oil tankers specified in 21.2.3.1 shall have the segregated ballast tanks which capacity shall be so determined that the ship may operate safely on ballast voyages without recourse to the use of cargo tanks for water ballast except as provided for in *MARPOL 73/78*, Annex I, Regulation 18.3 and 18.4. In all cases, however, the capacity of segregated ballast tanks shall be at least such that, in any ballast condition at any part of the voyage, including the conditions consisting of lightweight plus segregated ballast only, the ship's draughts and trim can meet each of the following requirements:

- the moulded draught amidships (without taking into account any deformation of the ship) shall not be less than:

$$T_1 = 2.0 + 0.02L \quad [\text{m}] \quad (21.2.3.2)$$

- the draughts at forward and after perpendiculars shall correspond to those determined in accordance with formula 21.2.3.2, with the trim by the stern of not greater than $0.015L$;
- in any case the draught at the after perpendicular shall not be less than that necessary for full immersion of the propeller.

The above specified segregated ballast tanks shall be arranged in accordance with the requirements specified in Regulation 18.12 ÷ 18.15 of Annex I to *MARPOL 73/78*.

When determining the shell area of double bottom tanks/spaces necessary to comply with the requirements of Regulation 18.13, as well the minimum height of such tanks/spaces to comply with the requirements of Regulation 18.15, suction wells meeting the requirements of 21.2.2.5 may be neglected.

It is recommended that oil tankers of the length $L < 150$ m, irrespective of the requirements specified in paragraph 21.2.3.2, should meet also the requirements included in Unified Interpretations of Regulation 18.5 of Annex I to *MARPOL 73/78*.

21.2.3.3 In calculating the aggregate capacity of tanks in accordance with the requirements specified in paragraph 21.2.3.2, the following shall be taken into account:

- the capacity of engine-room ballast tanks shall be excluded from the aggregate capacity of ballast tanks,
- the capacity of ballast tank located inboard of double hull shall be excluded from the aggregate capacity of ballast tanks, as shown in Fig. 21.2.3.3-1,
- any ballast carried in localized inboard extensions, indentations or recesses of the double hull, such as bulkhead stools, shall be excess ballast above the minimum requirement for segregated ballast capacity.

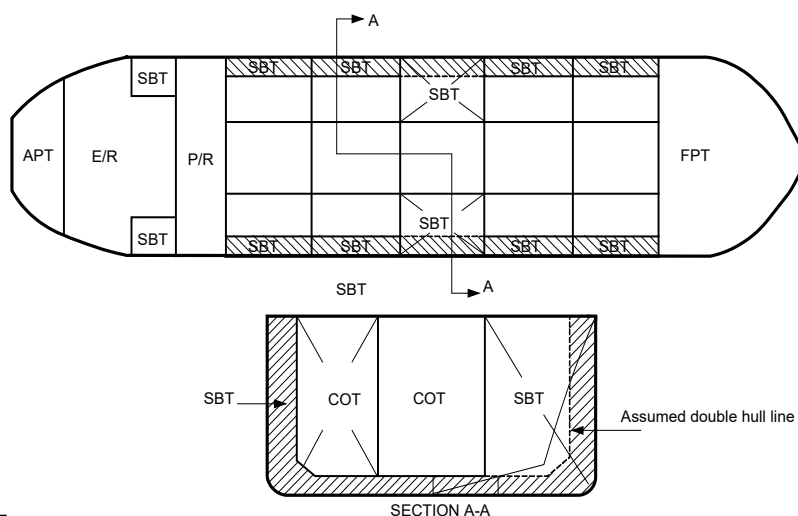

–Fig. 21.2.3.3-1

Spaces such as void spaces located in the double hull within the cargo tank length may be included in the aggregate capacity of ballast tanks, as shown in Fig. 21.2.3.3-2.

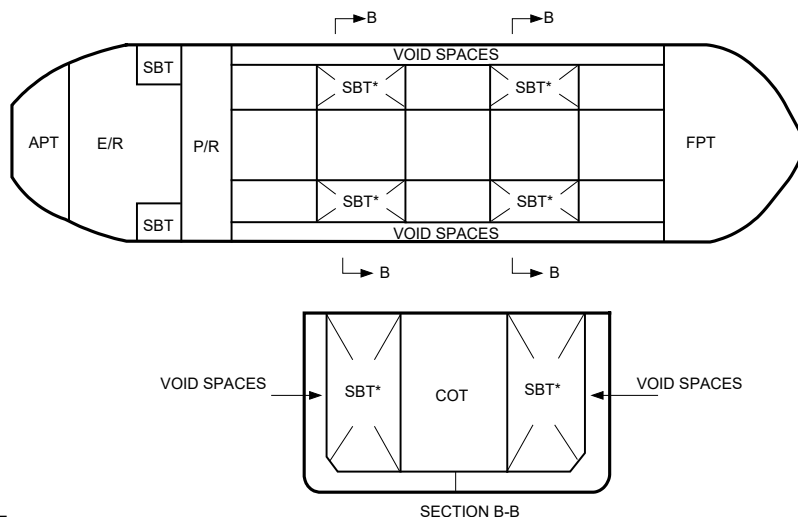

Fig. 21.2.3.3-2

The symbols used in Figures 21.2.3.3-1 and 21.2.3.3-2 are defined as follows:

- APT – after peak tank,
- FPT – forepeak tank,
- E/R – engine room,
- P/R – pump-room,
- SBT – segregated ballast tank,
- COT – cargo oil tank.

21.2.4 Cargo Tanks of Oil Tankers

21.2.4.1 The length of each cargo tank shall not exceed 10 m or one of the following values, whichever is the greater:

- where no longitudinal bulkhead is provided inside the cargo tanks:

$$l = \left(0.5 \frac{b_i}{B} + 0.1 \right) L \quad [\text{m}] \quad (21.2.4.1-1)$$

but not more than $0.2L$;

- where a centre plane longitudinal bulkhead is provided inside the cargo tanks:

$$l = \left(0.25 \frac{b_i}{B} + 0.15 \right) L \quad [\text{m}] \quad (21.2.4.1-2)$$

- where two or more longitudinal bulkheads are provided inside the cargo tanks:
 - a) for wing cargo tanks:

$$l = 0.2L \quad [\text{m}] \quad (21.2.4.1-3)$$

b) for centre cargo tanks:

$$\text{if } b_i / B \geq 0.2, \quad l = 0.2L \quad [\text{m}]; \quad (21.2.4.1-4)$$

if $b_i / B < 0.2$:

$$1) \quad l = \left(0.5 \frac{b_i}{B} + 0.1 \right) L \quad [\text{m}] \quad (21.2.4.1-5)$$

where no centre plane longitudinal bulkhead is provided,

$$2) \quad l = \left(0.25 \frac{b_i}{B} + 0.15 \right) L \quad [\text{m}] \quad (21.2.4.1-6)$$

where a centre plane longitudinal bulkhead is provided.

In the above formulae, b_i is the minimum distance from the ship's side to the outer longitudinal bulkhead of the tank in question measured inboard at right angles to the centre plane at the level corresponding to the assigned summer freeboard.

21.2.4.2 In the case of oil tankers delivered before 1 August 2010, irrespective of provisions set forth in 21.2.4.1, the size and arrangement of cargo tanks shall comply with the requirements specified in Regulations 26.2 and 26.3 of Annex I to *MARPOL 73/78*.

21.2.5 Pump-Rooms of Oil Tankers

21.2.5.1 The requirements specified in sub-chapter 21.2.5 apply to oil tankers of 5,000 tons deadweight and above. They are equivalent to the requirements specified in Regulation 22 of Annex I to *MARPOL 73/78*, introduced by IMO by Resolution MEPC. 117(52).

21.2.5.2 The pump-room shall be provided with a double bottom – except for the cases specified in 21.2.5.3.

The height of the double bottom shall be such that distance h between the bottom of the pump-room and the ship's base plane measured at right angles to the base plane at any cross-section will not be less than:

$$h = \frac{B}{15} \quad [\text{m}] \quad (21.2.5.2)$$

or $h = 2.0$ m, whichever is the lesser.

The value of h , however, shall not be less than 1.0 m.

The double bottom protecting the pump-room can be a void tank, a ballast tank or, unless prohibited by other regulations, a fuel oil tank.

Ballast piping is permitted to be located within the pump-room double bottom, provided any damage to that piping does not render the ship's pumps located in the pump-room ineffective.

In the double bottom, bilge wells may be located, but they shall be as small as practicable.

The distance between the bilge well bottom and the bottom plating, measured at right angle to the base plane shall not be less than $0.5h$.

21.2.5.3 Double bottom in way of the pump-room will not be required if:

- a) the bottom plate of the pump room is located above the base plane at the distance greater than the height h required in 21.2.5.2 (e.g. gondola stern designs);
- b) flooding of the pump-room would not render the ballast or cargo system inoperative.

Where a part of the pump-room is situated at the distance from the ship's base plane less than that required in 21.2.5.2, application of a double bottom is required only in this part of the pump-room.

21.3 Materials and the Scantlings of Structural Members

21.3.1 Materials

Materials shall comply with the requirements specified in Chapter 2. The requirements regarding quality and strength of materials different from hull structural steel will be specially considered by PRS in each particular case.

21.3.2 Design Loads

The design pressure in tanks for crude oil, fuel oil and high density liquids shall be determined in accordance with the requirements specified in 16.3.

21.3.3 Plating and Stiffeners

The thickness of plating and the scantlings of stiffeners shall be calculated in accordance with the requirements specified in Chapter 13.

21.3.4 Bulwarks and Guard Rails

Within the tank area, guard rails meeting the requirements specified in *Part III – Hull Equipment* shall be arranged. After considering the deck arrangement and the possibility of gas accumulation, PRS may accept arrangement of plate bulwarks complying with the requirements specified in sub-chapter 10.5 of the present Part of higher extent than that determined in 9.5, *Part III – Hull Equipment*.

21.3.5 Primary Supporting Members

21.3.5.1 The scantlings of primary supporting members shall be based on the requirements specified in Chapter 13. The zone strength analysis, in accordance with the requirements specified in Chapter 14, shall be conducted for complex primary supporting member system, when deemed necessary by PRS.

Such analysis shall be conducted, in particular, for:

- transverse and longitudinal primary supporting members in cargo tanks in ships with $L_0 > 120$ m,
- transverse bulkhead primary supporting members,

- primary supporting members in double bottom tanks where the tank breadth is equal to that of ship and ship's length $L_0 > 120$ m.

Recommended calculation methods are given in *Publication 19/P – Zone Strength Analysis of Hull Structure in Tankers*.

21.3.5.2 The direct stress analysis for primary supporting member systems shall be conducted for the load condition (LC) given in the above-mentioned Publication.

The scantlings of the transverse primary supporting members of tank bulkheads shall be determined for the most severe combination of loading.

21.3.6 Strengthening of Bottom Forward

21.3.6.1 General

For oil tankers subject to the requirements specified in sub-chapter 21.2.3, the strengthening of the bottom forward shall be based on the draught using the segregated ballast tanks only.

21.3.6.2 Scantlings

Determination of scantlings meeting the above requirements shall be conducted in accordance with the requirements specified in 6.4.

21.3.7 Fatigue Strength of Hull Structure

Fatigue strength of hull structural elements made of higher strength structural steel shall be checked in accordance with the requirements specified in *Publication 45/P – Fatigue Strength Analysis of Ship Steel Hull Structure*.

In special cases PRS may require checking the fatigue strength of hull structural elements made of normal strength steel.

21.3.8 Coating Standard for cargo oil tanks of crude oil tankers¹

21.3.8.1 Coating Standard is based on specifications and requirements to provide a target useful coating life of 15 years, which is considered to be the time period, from initial application, over which the coating system is intended to remain in „GOOD” condition². The actual useful life³ will vary, depending on numerous variables including actual conditions encountered in service.

21.3.8.2 Protective coatings for cargo oil tanks applied during the construction of new crude oil tankers shall at least comply with the requirements in this Coating Standard.

21.3.8.3 An epoxy-based system meeting test and physical properties (see Table 1 in Annex to Resolution MSC.288(87), as amended) shall be documented, and a *Type Approval Certificate* or *Statement of Compliance* shall be provided.

21.3.8.4 The following areas are the minimum areas that shall be protected according to this Coating Standard:

- .1** Deckhead with complete internal structure, including brackets connecting to longitudinal and transverse bulkheads. In tanks with ring frame girder construction, the underdeck

¹ Crude oil tanker is as defined in regulation 1 of Annex I of *MARPOL 73/78*.

² “GOOD” condition is the condition with minor spot rusting as defined in Resolution A.1049(27) for assessing the ballast tank coatings for tankers.

³ Target useful life is the target value, in years, of the durability for which the coating system is designed.

transverse framing to be coated down to level of the first tripping bracket below the upper faceplate.

- .2 Longitudinal and transverse bulkheads to be coated to the uppermost means of access level. The uppermost means of access and its supporting brackets to be fully coated.
- .3 On cargo tank bulkheads without an uppermost means of access, the coating shall extend to 10% of the tanks height at centerline but need not extend more than 3 m down from the deck.
- .4 Flat inner bottom and all structure to a height of 0.3 m above inner bottom to be coated.

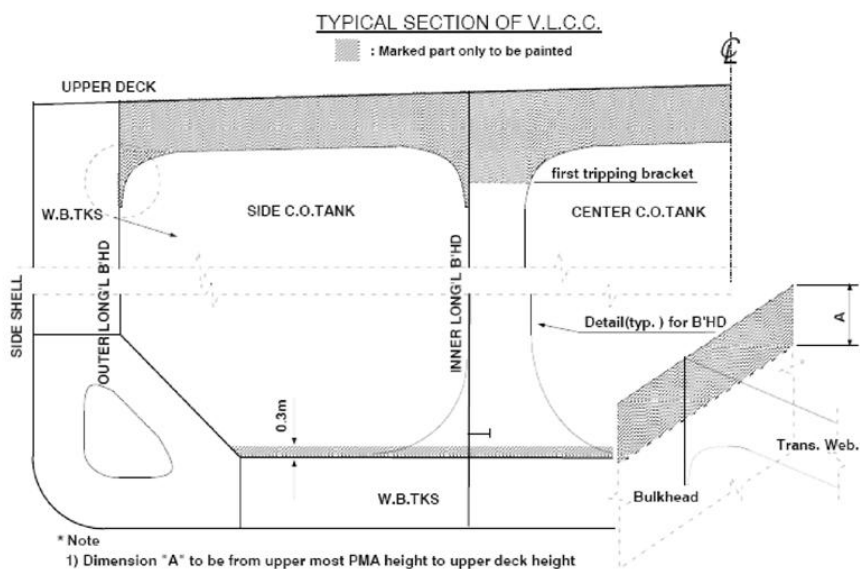

Fig. 21.3.8.4

21.3.8.5 Special Application

- .1 This Coating Standard covers protective coating requirements for steel structure within cargo oil tanks. It is noted that there are other independent items that are fitted within the cargo oil tanks and to which coatings are applied to provide protection against corrosion.
- .2 It is recommended that this Coating Standard is applied, to the extent practicable, to those portions of means of access provided for inspection within the areas specified in paragraph 21.3.8.4 that are not integral to the ship structure, such as rails, independent platforms, ladders, etc. Other equivalent methods of providing corrosion protection for non-integral items may also be used, provided they do not impair the performance of the coatings of the surrounding structure. Access arrangements that are integral to the ship structure, such as stiffener depths for walkways, stringers, etc., shall fully comply with this Coating Standard when located within the coated areas.
- .3 It is also recommended that supports for piping, measuring devices, etc., be coated as a minimum in accordance with the non-integral items indicated in paragraph 21.3.8.5.2.

21.3.8.6 The requirements for protective coating systems to be applied at ship construction for the cargo oil tanks of crude oil tankers meeting the Performance Standard specified in paragraph 21.3.8.1 are listed in table 1 in Annex to Resolution MSC.288(87), as amended.

21.3.9 Corrosion Resistant Steel Standard for Alternative Means of Corrosion Protection¹ for Cargo Oil Tanks of Crude Oil Tankers²

21.3.9.1 Corrosion Resistant Steel Standard is based on specifications and requirements which intend to provide a target useful life of 25 years, which is considered to be the time period, from initial application, over which the thickness diminution of the steel is intended to be maintained in cargo oil tanks and watertight integrity is intended to be maintained. The actual useful life³ will vary, depending on numerous variables including actual conditions encountered in service.

21.3.9.2 Corrosion resistant steel⁴ for cargo oil tanks applied to the area specified in 21.3.9.4 during the construction of crude oil tankers shall at least comply with the requirements for corrosion resistant steel given in *PRS Rules for the Classification and Construction of Sea-going Ships, Part IX – Material and Welding*, sub-chapter 8.5 and this should be considered as a minimum.

21.3.9.3 Special Application

- .1 Corrosion Resistant Steel Standard covers corrosion resistant steel requirements for ship's steel structures. It is noted that other independent items are fitted within the tanks to which measures are applied to provide protection against corrosion.
- .2 It is recommended that Corrosion Resistant Steel Standard or the Coating Standard for protective coating for cargo oil tanks is applied, to the extent possible, to those portions of permanent means of access provided for inspection within the area specified in 21.3.9.4 that are not integral to the ship's structure, such as rails, independent platforms, ladders, etc. Other equivalent methods of providing corrosion protection for the non-integral items may also be used, provided they do not impair the performance of the corrosion resistant steel of the surrounding structure. Access arrangements that are integral to the ship structure, such as increased stiffener depths for walkways, stringers, etc., shall fully comply with this Corrosion Resistant Steel Standard or the Coating Standard for protective coating for cargo oil tanks, when located within the areas specified in 21.3.9.4.
- .3 It is also recommended that supports for piping, measuring devices, etc., be provided with corrosion protection in accordance with the non-integral items indicated in 21.3.9.3.2.

21.3.9.4 The following areas are the minimum areas that shall be protected according to this Corrosion Resistant Steel Standard:

- .1 Deckhead with complete internal structure, including brackets connecting to longitudinal and transverse bulkheads. In tanks with ring frame girder construction, the underdeck transverse framing to be protected down to level of the first tripping bracket below the upper faceplate.
- .2 Longitudinal and transverse bulkheads to be protected to the uppermost means of access level. The uppermost means of access and its supporting brackets to be fully protected.
- .3 On cargo tank bulkheads without an uppermost means of access the protection shall extend to 10% of the tanks height at centerline but need not extend more than 3 m down from the deck.

¹ Alternative means is a means that is not utilization of protective coating applied according to the Coating Standard for protective coating for cargo oil tanks of crude oil tankers (*Resolution MSC.288(87), as amended*). The standard described in 21.3.9 is based on *Resolution MSC.289(87)*.

² See footnote 1 on p. 285.

³ See footnote 3 on p. 285.

⁴ Corrosion resistant steel is steel whose corrosion resistance performance in the bottom or top of the internal cargo oil tank is tested and approved to satisfy the requirements in the Corrosion Resistant Steel Standard in addition to other relevant requirements for ship material, structure strength and construction.

- .4 Flat inner bottom and all structure to a height of 0.3 m above inner bottom to be protected.

21.3.9.5 The requirements for corrosion resistant steel to be applied at the ship construction for cargo tanks in crude oil tankers meeting the Performance Standard specified in 21.3.9.1 shall use approved corrosion resistant steels according to the conditions specified in the *Type Approval Certificate* and the Technical File¹ to protect the area of application indicated in 21.3.9.4.

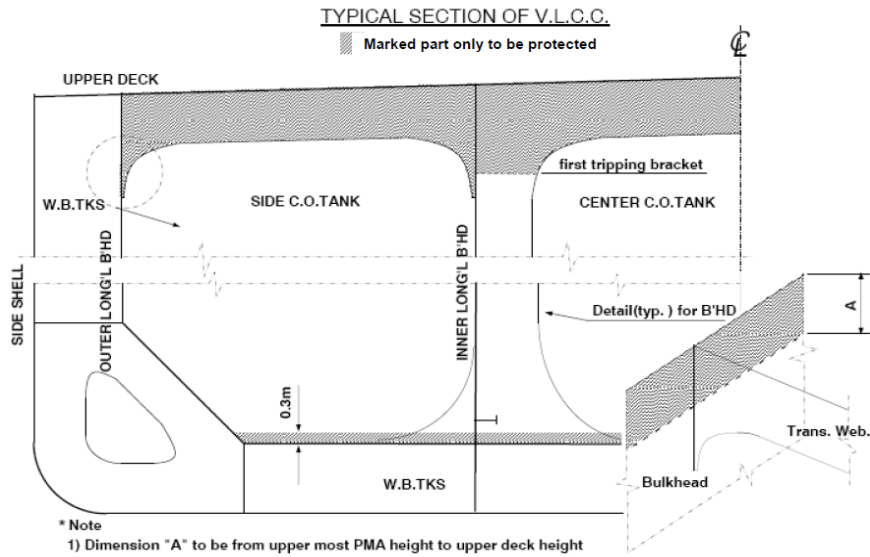

Fig. 21.3.9.4

¹ Technical file – as required by *Res. MSC.289 (87)*, in Annex ‘Performance Standard for Corrosion Resistant Steel’ – shall be verified by the Administration and be kept aboard and maintained throughout the life of the ship.

22 FISHING VESSELS

22.1 General

22.1.1 Application

22.1.1.1 The requirements specified in the present Chapter apply to fishing vessels.

The requirements shall be regarded as complementary to the basic requirements given in Chapters 1÷17.

22.1.1.2 In addition to the requirements specified in the present Part of the *Rules*, fishing vessels shall comply with the provisions of Council Directive 97/70/EC of 11 December 1997 of European Communities, as amended by Commission Directive 2002/35/EC of 25 April 2002.

22.1.2 Classification

Vessels built in accordance with the requirements specified in the present Chapter may be affixed with the additional mark in the symbol of class: **FISHING VESSEL**.

A vessel complying with the requirements specified in paragraph 22.1.3.2 may be affixed with the additional mark **MS**.

22.1.3 General Requirements

22.1.3.1 The present requirements apply to all vessels specified in 22.1.1, irrespective of fishing or catching arrangement.

Stern trawlers shall comply with the requirements specified in sub-chapter 22.3. Side trawlers shall comply with the requirements specified in sub-chapter 22.4.

22.1.3.2 The construction of vessels which may be secured alongside other vessels at sea (and especially the extent and size of side strengthenings) shall comply with the requirements specified in *Publication 20/P – Ship Side Strengthening of Fishing Vessels Mooring at Sea Alongside Other Vessels*.

22.1.4 Documentation

22.1.4.1 Technical documentation, specified in 1.4.2, shall be submitted to PRS for consideration and approval.

22.2 Structural Design and Scantlings of Structural Members

22.2.1 Bow Height

The minimum bow height shall not be less than that required by Regulation 39 and the sheer of the upper deck shall not be less than that required by Regulation 38 in Annex I of the *International Convention on Load Lines, 1966*.

22.2.2 Holds

22.2.2.1 In holds in which salted fish or salt in bulk is stored, the thickness of the inner bottom plating and of the bottom plates of the transverse watertight bulkheads forming the hold boundaries shall be increased by 1 mm, while the thickness of the bottom plates of watertight bulkheads between such holds shall be increased by 2 mm as compared with the basic requirements (see Chapters 6 and 9, respectively).

22.2.2.2 Where there is no inner bottom in holds under consideration, the thickness of webs and face plates of the centre girder, side girders and floors shall be increased by 1.5 mm, and that of the bottom plating by 1 mm as compared with the basic requirements (see Chapters 6 and 7, respectively).

22.2.3 Processing Spaces

22.2.3.1 Where, in a processing space located above the bulkhead deck, the number of bulkheads is less than that required by 9.2 and the distance between the bulkheads forming boundaries of that space exceeds 30 m, the structure of sides and transverse bulkheads within this area will be specially considered by PRS in each particular case.

22.2.3.2 In processing spaces where the deck plating is subject to the effect of refuse of processed fish and water, the thickness of the plating shall be increased by 1 mm as compared with the basic requirements (see Chapter 8).

The thickness of deck plating in places where salted fish or salt in bulk is stored shall be increased in the same way.

In way of decks, the plating of transverse bulkheads forming boundaries of the processing spaces shall be increased in thickness by 1 mm to a height of at least 500 mm above the deck plating.

22.2.3.3 The section modulus of beams and longitudinals of the deck, on which the processing gear is located, shall be determined for design load taken as specified in Chapter 16, but not less than that determined in accordance with the following formula:

$$p = 15 \frac{M}{F} \quad [\text{kPa}] \quad (22.2.3.3)$$

M – mass of processing gear, [t];

F – deck area in way of the processing gear, [m²].

22.2.4 Double Bottom

Watertight double bottom shall be applied in ships of length not less than 75 m.

If possible, the double bottom should extend from the fore peak bulkhead to the after peak bulkhead.

22.2.5 Bulwarks

The bulwark stays in fishing vessels shall be fitted at least at every second frame. The thickness of bulwark plating shall not be less than 80% of the Rule thickness of the shell plating.

22.3 Stern Trawlers

22.3.1 Stern Ramp Structure

22.3.1.1 Side walls of the ramp shall be extended downwards to the shell plating and forwards to the after peak bulkhead. Ramp sides shall pass smoothly into the deck primary supporting members.

22.3.1.2 Where there is a ramp, a flat form of the lower part of the stern counter shall be avoided. The connection of the side walls of the ramp with transom plating, deck plating and bottom part of stern counter plating shall be rounded with a radius not less than 200 mm. The connection by means of a round rod of not less than 70 mm in diameter may be permitted. Where the trawl shall be brought on board by means of a ramp, it is recommended to apply the longitudinal framing of the ramp deck.

In this case, the deck transverses shall be spaced not more than 4 frame spaces apart. Distances between deck longitudinals of the ramp shall not exceed 600 mm.

On whale vessels and where the trawl shall be brought on board on special trucks or by other means of transportation, transverse framing shall be applied in the construction of ramps.

22.3.2 Design Loads

22.3.2.1 Where the trawl shall be pulled on board, the design load for the side walls and the ramp shall be determined by the formula:

$$p = 6.5b \quad [\text{kPa}] \quad (22.3.2.1)$$

b – width of the ramp, [m].

If the width of the ramp is changed within its length, the least width shall be taken for calculations.

22.3.2.2 The design loads for the structural members of the ramp on ships where special wheeled transport vehicles are used, shall be taken as:

$$p = 27 \frac{M_1 + M_2}{n} \quad [\text{kPa}] \quad (22.3.2.2)$$

M_1 – maximum rated mass of the catch which the vehicle is capable of transporting, [t];

M_2 – mass of the movable part of the vehicle, [t];

n – number of the vehicle axles.

22.3.2.3 Design load for the walls of the ramp on a ship where special wheeled transport vehicles are used shall be determined in accordance with formula 22.3.2.1.

22.3.2.4 The assumed design loads for the ramp and its walls shall not be less than those calculated from Chapter 16.

22.3.3 Ramp Plating

22.3.3.1 The thickness of the ramp plating on ships with trawl to be pulled on board shall not be less than:

$$t = K_0 s \sqrt{\frac{p}{\sigma}} + t_{k1} \quad [\text{m}] \quad (22.3.3.1)$$

p – design pressure determined in accordance with formula 22.3.2.1, [kPa];

s – spacing of beams, [m];

K_0, t_{k1} – parameters determined in accordance with Table 22.3.3.1;

$\sigma = 0.8 R_e$ – allowable stress, [MPa].

Table 22.3.3.1
Factors K_0 and t_{k1}

Item	Type of structure	Area in way of ramp	Ship type					
			Fishing vessels		Special purpose ships (except whale mother ships)		Whale mother ships	
			K_0	t_{k1}	K_0	t_{k1}	K_0	t_{k1}
1	Ramp	Lower roundings and shell plating of the counter	33.5	10.0	33.5	10.0	See 22.3.3.3	
		Mid portion		5.5		5.5		
		Upper roundings		9.5		5.5		
2	Walls of ramp	In way of rope friction	32.4	5.5	27.4	5.5	32.4	10.0
		In the remaining area		4.5		4.5		5.5

22.3.3.2 The length of the thickened regions of plating along the ramp shall be:

- in way of the lower rounding – not less than the ramp width measured from the front of the ramp forwards;
- in way of the upper rounding – not less than twice the ramp width.

The plates of the stern counter shell plating shall be thickened along the distance not less than 1 m measured from the front of the ramp forwards and along the width not less than the ramp width.

22.3.3.3 It is recommended to use an adequate arrangement to protect the ramp plating against wear by ropes when pulling in the fish. If the pull in a single rope exceeds 30 kN, the use of such equipment is obligatory. Where such arrangement is used, the plating thickness in the upper portion may be determined in accordance with paragraph 22.3.3.1 for the mid portion of the ramp deck. Instead of the wear protecting equipment, double plates may be used in way of strengthenings of the lower and upper roundings along the whole width of the ramp and double strakes of not less than 400 mm in width by the ramp walls along the remaining length of the ramp. In this case, the plating thickness along the ramp length may be taken as for the mid portion of the ramp in accordance with the requirements specified in paragraph 22.3.5.1.

22.3.3.4 Irrespective of the mode of fish transport through the ramp, the ramp plating thickness shall be by 2 mm greater than that required in sub-chapter 13.2.

22.3.3.5 The thickness of the walls of recesses in the ramp shall not be less than that required in sub-chapter 13.2 for the shell plating.

22.3.4 Deck Framing of Ramp

22.3.4.1 The section modulus of deck longitudinals, deck beams and deck transverses of the ramp in ships pulling in the trawl shall not be less than:

$$W = \frac{10^3 s p l^2}{K_w \sigma} \quad [\text{cm}^3] \quad (22.3.4.1)$$

- s – spacing of members under consideration measured in ramp deck plane, [m];
- K_w – see table 22.3.4.1;
- p – design pressure, see paragraph 22.3.2.1, [kPa];
- l – span of the considered member measured between supports, [m];
- σ – 140k [MPa].

Table 22.3.4.1
Factor K_w

Item	Framing of the ramp deck	Ship type		
		Fishing vessels	Special purpose ships (except whale mother ships)	Whale mother ships
1	Deck longitudinals	11.3	7.9	23.5
2	Deck transverses	12.6	8.8	21.1
3	Stiffeners of ramp walls	13.8	18.5	5.2

22.3.4.2 The section modulus of the ramp beams on ships where special wheeled means of transport are used shall not be less than that determined in accordance with formula 22.3.4.1,

assuming $K_w = 9.3 f^2 \sqrt{\frac{s}{l}}$ and the pressure p calculated in accordance with paragraph 22.3.2.2.

22.3.5 Plating of Ramp Walls

22.3.5.1 In vessels not engaged in pelagic fishing, the strakes of the wall plating shall be thickened in way of connection with transom and along the ramp. The thickness of these strakes shall not be less than that determined in accordance with formula 22.3.3.1. The thickened strakes of the wall plating along the ramp shall have a width not less than 0.4 of the ramp width or 1 m, whichever is the greater. Where the trawl is pulled in, the lower edges of the strakes shall extend to the ramp or where special wheeled means of transport or similar means are used, they shall extend to the level the fish is put on. The thickened part of the wall plating in way of transom forward from the point where flat portion of the wall and the rounding meet, shall not be less than 0.5 the ramp width. In way of a rounded transition of the wall plating into transom plating, the thickness of the plating strake of not less than 700 mm in width, measured from the ramp plating, shall not be less than 20 mm. Doubling plates may be used alternatively.

Along the transition line of the flat portion of the wall into the rounded one, at a distance not greater than 200 mm from the transom, semicircular rods 70 mm in diameter shall be welded on.

22.3.5.2 In vessels engaged in pelagic fishing, the ramp walls shall be strengthened by longitudinal semicircular rods of not less than 70 mm in diameter, at spacings not exceeding 200 mm. The edge of the upper rod shall be located at a distance not greater than 650 mm from the ramp. The thickness of the lower strake of wall plating in the area extending from the ramp to the level of at least 100 mm above the upper semicircular rod shall not be less than:

$$t = \frac{85s_1}{k} + 1 \quad [\text{mm}] \quad (22.3.5.2)$$

s_1 – spacing between the edges of adjacent semicircular rods, [m].

In each case, the thickness of wall plating and wall recesses to the level of the upper deck level shall not be less than that required in sub-chapter 13.2 for the shell plating and, above that level – not less than that required in sub-chapter 13.4.

22.3.6 Framing of Ramp Walls

The section modulus of the ramp wall stiffeners shall not be less than that determined in accordance with formula 22.3.4.1, assuming the maximum span of the stiffener, measured from the deck to the nearest deck or between the two decks adjacent to the wall, not less, however, than 2.6 m. For vessels engaged in pelagic fishing, the section modulus of the stiffener shall not be less than:

$$W = \frac{l-0.5}{l} \left(\frac{170}{k} - \frac{51}{s} \right) \quad [\text{cm}^3] \quad (22.3.6)$$

- l – span of stiffener in accordance with the above requirement, [m];
 s – spacing of stiffeners, [m].

In each case, the section modulus of ramp wall stiffeners shall not be less than that required in sub-chapter 13.5.

22.3.7 Strengthenings of After End

The thickness of the transom plating shall be by 1 mm greater than that required in 13.2 for ship's ends. The transom plating shall be protected against wear by means of diagonally welded halfround steel rods of at least 70 mm in diameter.

22.4 Side Trawlers

22.4.1 Forecastle

It is recommended that side trawlers with length $L > 30$ m be fitted with a forecastle.

22.4.1.1 Strengthenings in Way of Gallows

In way of each gallow, including area between the cross-section situated at 3 frame spaces forward and abaft from the ends of the gallows, the following strengthening shall be provided:

- intermediate frames extending from the upper deck to the level not less than 0.5 m below the ballast waterline, having the section modulus not less than 75% of that required by 13.5. The upper and lower ends of intermediate frames shall be attached to longitudinal intercostal members fitted between the main frames. These members shall be of the same cross-sectional area as intermediate frames and shall be fitted in one line. The upper intercostal members shall be fitted at a distance not exceeding 350 mm from the upper deck;
- the bulwark stays fitted at every frame;
- the thickness of the structural members shall be increased as follows:
 - sheer strake – by 2 mm as compared with that required in 22.4.3,
 - the strake of plating adjacent to the sheer strake shall have the same thickness as the sheer strake,
 - deck stringer – by 3 mm as compared with that required in 13.2 and in Chapter 8,
 - bulwark – by 2 mm as compared with that required by Chapter 10;
- steel bars of semicircular section welded diagonally to bulwark, sheer strake and side plating above the ballast waterline level.

22.4.2 Side Plating between Gallows

In way between forward and after gallows, the thickness of the side plating and sheer strake shall be increased by 1 mm as compared with that required in 13.2.

23 TUGS AND SUPPLY VESSELS

23.1 General

23.1.1 Application

The requirements specified in the present Chapter apply to vessels intended for towing operations and to vessels specially designed for services to offshore installations.

The requirements shall be regarded as complementary to the basic ones given in Chapters 1÷17.

23.1.2 Classification

Vessels built in accordance with the requirements specified in the present Chapter may be affixed with the additional mark in the symbol of class:

TUG

SUPPLY VESSEL.

23.1.3 Definitions

s_s – standard frame spacing determined in accordance with the following formula:

$$s_s = 0.48 + 0.002 L_0 \quad [\text{m}] \quad (23.1.3)$$

but not more than 0.6 m within the areas forward of the collision bulkhead and aft of the after peak bulkhead;

s – spacing of stiffeners, measured along plating, [m];

l – span of stiffener or primary supporting member, [m].

23.1.4 Documentation

23.1.4.1 Technical documentation, specified in 1.4.2, shall be submitted to PRS for consideration and approval.

23.2 Tugs

23.2.1 Scantling of Structural Members

23.2.1.1 For determining the scantlings of structural members in tug, the design draught $T = T_H \geq 0.9H$, [m] shall be taken.

23.2.2 Side Stringers in Fore Peak

23.2.2.1 Forward of the collision bulkhead, horizontal side stringers shall be arranged on the ship's sides not more than 2 m apart. The stringers shall be connected to the collision bulkhead by brackets.

23.2.2.2 The dimensions of stringers shall not be less than:

- web height: $h_s = 250 + 5L_0$ [mm];
- web thickness: $t_s = 6.5 + 0.02L_0$ [mm];
- flange cross-sectional area $A_m = 5 \text{ cm}^2$.

23.2.2.3 Stringers shall be supported by panting beams not more than 2 frame spaces apart. The sectional area of beams shall not be less than:

$$A_p = 5 + 2B \quad [\text{cm}^2] \quad (23.2.2.3)$$

For beams not supported by a longitudinal partition at the ship's centre line, the sectional area shall be increased by 50%.

23.2.2.4 Beams shall extend to the frames and shall be connected to stringers and frames by a weld with an area not less than 40% of the beam sectional area.

23.2.2.5 Intermediate frames shall be connected to the stringer by a stiffener, the weld area being not less than 40% of the sectional area of the intermediate frame.

23.2.3 Side Fenders

Fenders of adequate strength shall be fitted at deck level along the whole length of the ship (loose fenders may be approved if the upper part of the ship's side is additionally stiffened).

It is recommended that the design of sides in tug provide for the pressure caused by external objects being distributed within the largest possible area.

23.2.4 Machinery Casings

23.2.4.1 Plating thickness and stiffener scantlings of engine and boiler room casings, not protected by deckhouses, shall be at least 20% in excess to the basic requirements.

23.2.4.2 The scantlings of skylight coamings shall be as in exposed casings.

23.2.4.3 When the length of casing is greater than the ship's breadth, a continuous transverse deck primary supporting member is recommended to be fitted in the mid-length of the casing.

23.2.5 Strengthening in Way of Towing Arrangement

Seatings of the towing hook, winch and bollards shall be adequately connected to hull or superstructure structural members.

The thickness of the plating in way of the seating of the said arrangements shall be increased by at least 60% in excess of the basic requirements.

23.3 Supply Vessels

23.3.1 Ship's Sides and Stern

23.3.1.1 Longitudinal fenders shall be fitted within areas exposed to possible damage on the ship's sides at upper and forecastle deck. Additional diagonal fenders shall be fitted in the forebody between the said longitudinal fenders.

23.3.1.2 The thickness of the side plating, including bilge strake, shall not be less than:

$$t = (6.5 + 0.05 L_0) \frac{S}{S_s} \quad [\text{mm}] \quad (23.3.1.2)$$

however, not less than 9 mm; $\frac{S}{S_s} \geq 1$ shall be taken.

Where fenders are omitted, within areas exposed to possible damage, the thickness of the side plating at upper and forecastle deck shall not be less than twice that required above. The plating of increased thickness shall extend to a level of not less than 0.01 L_0 below the deck.

23.3.1.3 Within the areas exposed to possible damage and protected by fenders the section modulus of the main and 'tween deck frames shall not be less than:

$$W_1 = 1.5 L_0 I_s \quad [\text{cm}^3] \quad (23.3.1.3-1)$$

$$W_2 = 1.25 W \quad [\text{cm}^3] \quad (23.3.1.3-2)$$

whichever is the greater.

W – section modulus determined in accordance with the basic requirements.

If fenders are omitted within areas exposed to possible damage, the section modulus of the main and 'tween deck frames shall not be less than:

$$W = 2.5 L_0 I_s \quad [\text{cm}^3] \quad (23.3.1.3-3)$$

All frames shall be provided with end brackets. Scallop welds shall not be used in connections between side frames and shell plating.

23.3.1.4 Flat part of bottom in way of stern shall be efficiently stiffened.

23.3.1.5 The areas of stern structure subjected to heavy loads when handling anchors or other arrangements for drilling rigs shall be strengthened. The plate thickness shall not be less than twice the basic requirement determined in accordance with formula 23.3.1.2. The adjacent deck structure shall be strengthened accordingly.

23.3.2 Weather Deck for Cargo

23.3.2.1 The scantlings of the deck structural members shall be based on a minimum cargo load of 1.5 t/m², in combination with 80% of the design sea pressure determined in accordance with 16.2. Cargo loads exceeding 4 t/m² need not be combined with sea pressure. For intermediate loads, the percentage of the design sea pressure to be added shall be determined by linear interpolation.

23.3.2.2 Deck plating thickness shall not be less than 8 mm.

23.3.2.3 In deck areas for heavy cargo units, the deck structure shall be adequately strengthened.

23.3.2.4 Stowracks for deck cargo shall be provided. The stowracks shall be efficiently attached and supported. The scantlings of stowracks shall be based on a load not less than $6F_p$ [kN], assumed to be evenly distributed on the stowrack on one side of the vessel. F_p – total deck area between stowracks, [m²].

23.3.2.5 Bulwark plating thickness shall not be less than 7 mm. Bulwark stay depth shall not be less than 350 mm at deck. The spacing of bulwark stays shall not exceed 1.3 m.

23.3.2.6 The scantlings of the foundations and supports of towing equipment shall be based on the breaking strength of the towline.

23.3.3 Construction of Foundations

Pillars and primary supporting members supporting deck cargo and towing winches, foundations for separate cargo tanks, as well as supports of other heavy components shall have scantlings based on the supported mass, including dynamic loads due to the vessel's motion twice the values determined in Chapter 13.

23.3.4 Superstructure End Bulkheads and Deckhouse Walls and Decks

23.3.4.1 The plating thickness of the deckhouse sides, superstructure and deckhouse end bulkheads, as well as deckhouse deck shall not be less than:

$$t = t_0 + 0.02 L_0 \quad [\text{mm}] \quad (23.3.4.1)$$

$t_0 = 6$ for front bulkhead,
 $t_0 = 5$ for side and aft end bulkheads,
 $t_0 = 4.5$ for decks in deckhouses.

For stiffener or beam spacing exceeding 0.6 m, the required thickness shall be increased in proportion to the increased spacing.

23.3.4.2 The section modulus of the stiffeners and beams shall not be less than:

$$W = 0.7 l^2 s p \quad [\text{cm}^3] \quad (23.3.4.2)$$

p – design sea pressure determined in accordance with sub-chapter 16.2; at least the following values shall be taken:

$p \geq 20$ kPa for front bulkhead,
 $p \geq 13$ kPa for side and aft end bulkhead,
 $p \geq 10$ kPa for exposed deck,
 $p \geq 8$ kPa for accommodation deck.

23.3.4.3 Stiffeners of sides and end bulkheads shall have welded end connections. Beams shall be connected to wall stiffeners by brackets. Stiffeners on front bulkheads shall have brackets at their both ends.

23.3.5 Requirements for Tanks Containing Hazardous Liquids

23.3.5.1 The requirements of sub-chapter 23.3.5 are consistent with IMO Resolution A.673(16), as amended by Resolution MSC.236(82). These requirements are applicable to integral or independent tanks containing hazardous liquids. A detailed list of such liquids is given in Appendix 1 to the above-mentioned Resolution (sulphuric acid, hydrochloric acid, etc.).

23.3.5.2 Cargo tanks containing liquids, as specified in 23.3.5.1, shall be located at a distance not less than 760 mm measured inboard from the side of the vessel perpendicular to CP at the level of the summer load waterline.

23.3.5.3 Tanks containing liquids, as specified in 23.3.5.1, shall be segregated from machinery spaces, propeller shaft tunnels, dry cargo spaces, accommodation and service spaces, the crew food store-rooms – by means of cofferdams, void spaces, cargo pump-rooms, empty tanks, the tanks containing other liquids (except fresh water tanks and lubricating oil tanks).

The above-mentioned tanks may extend to the vessel bottom, but they cannot be located in the fore and aft peaks.

The spacing between the remaining boundaries of the tanks and the adjacent ship's structures shall not be less than 600 mm.

Cargo tanks may extend to the deck plating, provided dry cargo is not handled in that area or unless a continuous permanent deck sheathing of wood or other suitable material of appropriate thickness is fitted.

23.3.5.4 On-deck stowage of independent tanks or installing independent tanks in a cargo hold is considered as satisfying the requirements set forth in 23.3.5.3.

23.3.5.5 The type of cargo tanks used for the carriage of liquids, as specified in 23.3.5.1, shall comply with the requirements of the *International Code for the Construction and Equipment of*

Ships carrying Dangerous Chemicals in Bulk (IBC Code) or the International Code for the Construction and Equipment of Ships Carrying Liquefied Gases in Bulk (IGC Code), as applicable.

23.3.5.6 Instead of the use of permanently attached deck-tanks, portable tanks complying with the requirements of the *International Code for the Construction and Equipment of Ships carrying Dangerous Chemicals in Bulk (IBC Code)* or tanks specifically approved by the Administration may be used, provided they are properly located and secured to the ship.

23.3.5.7 Construction material for the tanks shall comply with the requirements specified in the *IBC Code* or the *IGC Code*, as applicable.

24 DREDGERS, HOPPER BARGES AND FLOATING CRANES

24.1 General

24.1.1 Application

The requirements specified in this Chapter apply to vessels specially intended for dredging and carriage of spoil and vessels intended for lifting operations.

The requirements shall be regarded as supplementary to the basic ones specified in Chapters 1÷17.

24.1.2 Classification

Vessels built in accordance with the requirements specified in this Chapter may be affixed with the additional mark in the symbol of class:

DREDGER – dredger,
HOPPER BARGE – hopper barge,
FLOATING CRANE – floating crane.

24.1.3 Documentation

Technical documentation, specified in sub-chapter 1.4.2, shall be submitted to PRS for consideration and approval

24.2 Structural Design and Scantlings of Structural Members of Dredgers and Hopper Barges

24.2.1 Corrosion Additions

Areas in way of spoil holds shall be regarded as unprotected against corrosion and the assumed corrosion additions shall be in accordance with the requirements specified in sub-chapter 2.5.

Where quick wear in the plating caused by stone or other material carried in the spoil holds may be expected, corrosion additions are subject to PRS acceptance in each particular case.

24.2.2 Longitudinal Strength

Hull section modulus, as well as sectional area of sides and longitudinal bulkheads shall fulfil the requirements specified in Chapter 15, regarding the most severe loading conditions corresponding to sea voyages, dredging operations and spoil discharging. The density of spoil not less than 1.2 t/m³ shall be taken for calculations.

24.2.3 Structure Scantlings

Scantlings of the structural members shall fulfil the requirements specified in Chapter 13, special consideration being paid to the local loads due to the specialised dredging equipment. Allowable stresses in hull supporting structures for fastening the dredging equipment and the extent of other local strengthenings corresponding to the operations carried out is subject to PRS acceptance in each particular case.

24.3 Structural Design and Scantlings of Structural Members of Floating Cranes

24.3.1 Hull structure shall comply with the basic requirements, taking into account strengthening necessary for supporting the crane during operation and in the parked position.

24.3.2 Transverse and longitudinal bulkheads receiving forces transferred onto the hull by the crane foundation shall be fitted in the hull.

25 CATAMARANS

25.1 General

25.1.1 Application

25.1.1.1 The requirements specified in this Chapter apply to catamarans of $24 \text{ m} < L_0 \leq 90 \text{ m}$ in length which are not high speed craft. The definition of high speed craft is provided in sub-chapter 1.2 of *Part I – Classification Regulations*.

Hull construction of catamarans of a length $L_0 > 90 \text{ m}$ is subject to PRS consideration in each particular case.

25.1.1.2 The requirements specified in this Chapter apply to unrestricted service catamarans with steel or aluminium-alloy hulls of the construction specified in sub-chapter 25.4, which are passenger ships, cargo ships, fishing vessels, etc.

For restricted service catamarans, the values of dynamic general loads (bending moments, torques, etc.) and local loads (external pressure induced by sea water, pressure induced by cargo, stores, etc.) may be reduced as follows:

- for operating area II by 10%,
- for operating area III by 30%.

25.1.2 Symbols

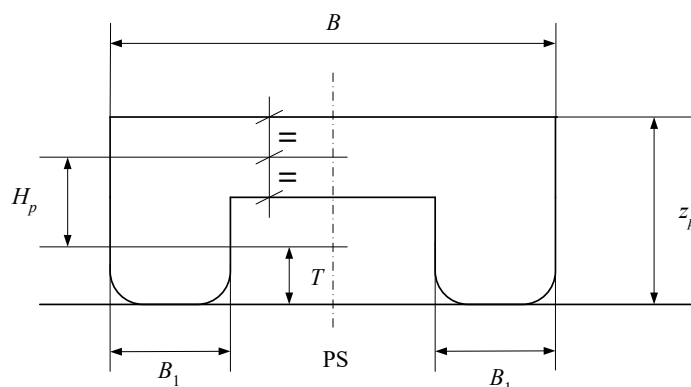

Fig. 25.1.2. Definition of some dimensions of catamaran hull

L, L_0 – length of catamaran and design length of catamaran, respectively [m], determined for an individual hull considered as a ship, like in 1.2.2;

B – breadth of catamaran [m] – maximum breadth of catamaran, measured between the outer edges of frames of the individual hull outer sides;

B_1 – breadth of individual hull [m] – maximum breadth measured between the outer edges of frames of the individual hull outer side and inner side (i.e. the side closer to the catamaran centre plane);

$B_p = B - 2B_1$ – breadth of cross-deck structure [m];

$B_s = 2B_1$ – combined breadth of individual hulls [m];

D – catamaran displacement [t] – measured at draught T ;

T – catamaran draught [m] – vertical distance from the base plane to the summer load waterline measured amidships;

- V – volume of moulded displacement [m³] – combined volume of individual hulls defined by the outer edges of frames at draught T ;
- H_p – vertical distance from the summer load waterline to the midheight of catamaran cross-deck structure measured at the centre plane [m];
- z_p – vertical distance from the base plane to the cross-deck structure deck at the side amidships [m];
- δ – moulded block coefficient calculated in accordance with the following formula:

$$\delta = \frac{V}{L_0 B_s T}$$

25.1.3 Documentation

Technical documentation shall be submitted to PRS for consideration and approval. The documentation scope in accordance with 1.4.2 shall be adjusted to the specific construction of catamaran hulls.

Particularly, drawings showing the construction of cross-deck structure connecting the catamaran individual hulls shall be submitted.

25.2 Materials and Welding

25.2.1 Materials

While selecting the grade of steel, the requirements specified in sub-chapter 2.2 shall be taken into account considering each individual hull as the hull of single-hull ship and the cross-deck structure as the bottom of the ship.

Plates of deck plating and of the cross-deck structure bottom as well as fore and after walls of the cross-deck structure in way of the cross-deck structure connection to the individual hulls located at the distance at least double frame spacing from the cross-deck structure connection to the individual hulls belong to class III of structural members.

25.2.2 Welding

While determining the characteristics of welds connecting structural members of catamaran hulls, the principles specified in Chapter 4 shall be applied considering each individual hull as a hull of single-hull ship.

The requirements for welds connecting structural members of the cross-deck structure are the same as for welds connecting structural members of single-hull ship bottom.

25.3 Subdivision

25.3.1 General Requirements

25.3.1.1 Individual hulls and the cross-deck structure shall be divided by transverse bulkheads into watertight compartments.

The following bulkheads are required:

- collision bulkhead,
- bulkheads forming the boundaries of machinery spaces.

25.3.1.2 Each passenger catamaran as well as catamarans of other types intended for various functions having a length more than 80 m shall fulfil the requirements for subdivision and stability index specified in sub-chapter 5.3 of *Part IV – Stability and Subdivision*.

25.3.2 Position and Vertical Extent of Collision Bulkheads

Collision bulkheads in individual hulls shall fulfil the requirements specified in sub-chapters 9.2.2 and 9.2.3.

25.4 Construction

25.4.1 Constructional Types of Individual Hull Connections

The requirements specified in sub-chapter 25.4 apply to individual hull connections effected by either of the following methods:

- over individual hulls, a deckhouse or superstructure of a length not less than half of the length of catamaran and including not less than 3 transverse bulkheads or divisions situated in the fore, midship and aft portions is applied.
- a special platform which forms the system transverse members covered with plating on both (top and bottom) sides or only on one (top) side is applied.

Other construction types applied to connections of individual hulls (e.g. platform which consist of several segments) are subject to PRS consideration in each particular case.

25.4.2 Construction of Individual Hull Connection

25.4.2.1 It is recommended that the cross-deck structure have a transverse framing system. Transverse members and transverse stiffeners of platings/plating of the cross-deck structure shall be coplanar with the corresponding members of individual hulls.

The construction of cross-deck structure shall be accessible for inspection and maintenance.

It is recommended that the cross-deck structure, including the top and bottom plating, be not less than 800 mm.

25.4.2.2 Where an opening (hatch) of a breadth exceeding 60% of that of the relevant deck is applied in the individual hull deck, adequate strengthening shall be provided to the cross-deck structure deck in way of such an opening. This strengthening shall extend fore and aft over the length approximately equal to the half of opening breadth.

25.4.2.3 If the connection of individual hulls is in the form of superstructure/deckhouse provided with bulkheads/divisions ensuring the strength of catamaran subjected to general transverse bending and torsion, then the individual hulls shall be provided by means of coplanar transverse bulkheads, divisions or sturdy frames.

In the superstructure/deckhouse divisions connecting individual hulls, openings of a height or breadth exceeding half the height of such a division shall not be applied. The possibility for making such openings is subject to PRS consent in each particular case.

25.4.2.4 It is recommended that the cross-deck structure with top and bottom platings be connected to the inner sides of individual hulls as shown in Fig. 25.4.2.4-1 and Fig. 25.4.2.4-2.

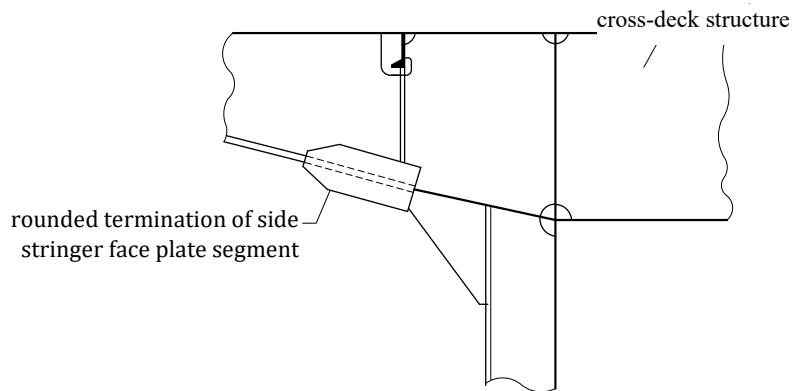

Fig. 25.4.2.4-1

Individual hull transverse girder depth at the inner side is equal to the cross-deck structure height. The depth may be reduced gradually along the distance from the inner side.

In the individual hulls, side stringer (Fig. 25.4.2.4-1) or rounded-edge brackets (Fig. 25.4.2.4-2) shall be provided at the level of cross-deck structure bottom plating.

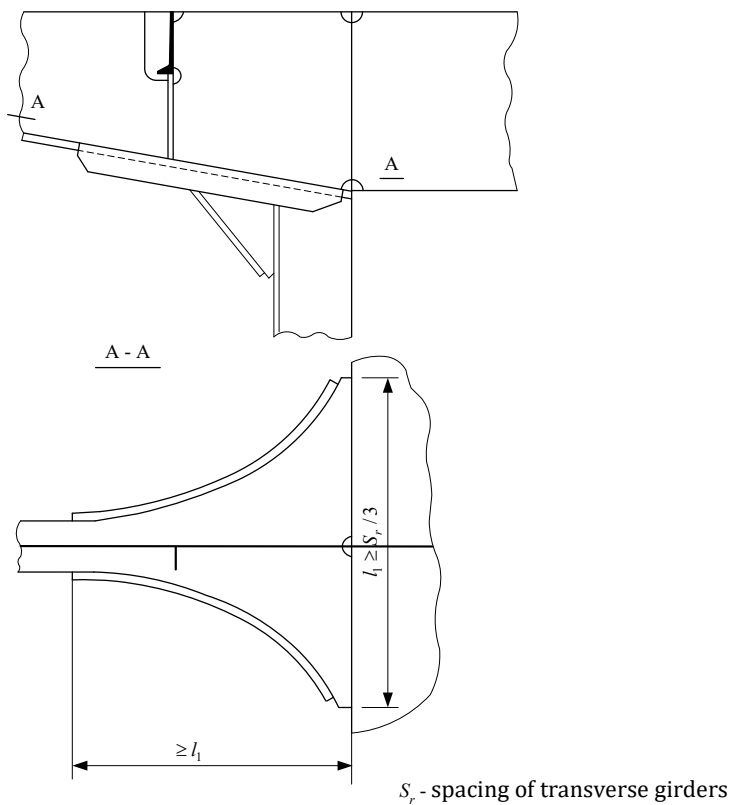

Fig. 25.4.2.4-2

25.4.2.5 For cross-deck structure with rounded bottom plating at the individual hull sides, the method of its connection to the individual hull sides is subject to PRS consideration in each particular case.

25.4.2.6 It is recommended that transverse girders of cross-deck structure without bottom plating be connected to the individual hull sides as shown in Fig. 25.4.2.6.

Other design solutions are subject to PRS consideration in each particular case.

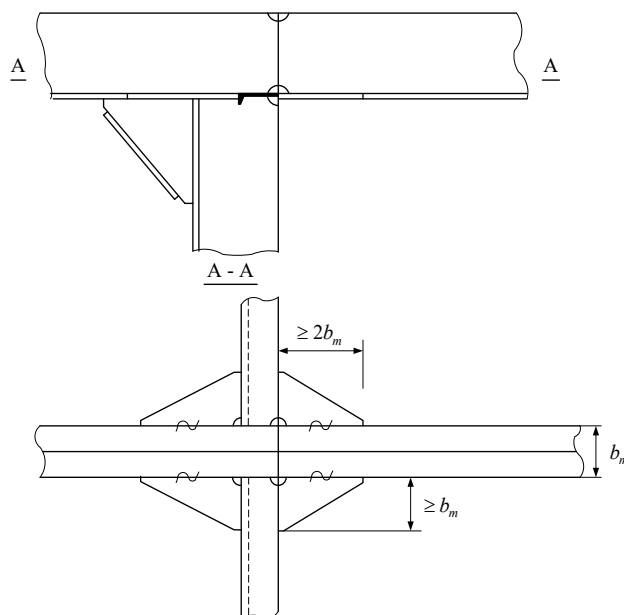

Fig. 25.4.2.6

25.4.2.7 In the cross-deck structure with transverse framing system, transverse stiffeners of plating/ platings of the spacing equal to the frame spacing shall be applied between transverse girders.

Stiffeners of top and bottom platings shall be connected to each other with brackets at the individual hull inner sides and at the cross-deck structure longitudinals.

The width of such brackets (measured perpendicularly to the centre plane) shall not be less than 0.3 the cross-deck structure height and thickness – not less than that of the transverse girders.

If the bracket height to its thickness ratio exceeds 35, then the free edge shall be stiffened by face plate or flange.

25.4.2.8 Stiffeners of the cross-deck structure top and bottom platings may be connected by vertical cross-ties situated at their midspan.

Cross-tie sectional area and moment of inertia shall not be less than the corresponding parameters of the lesser section of the connected stiffeners.

Application of cross-ties allows for the reduction by 40% of sectional moduli of the stiffeners of the cross-deck structure required in sub-chapter 25.5.

25.4.2.9 For longitudinal framing system of the cross-deck structure deck and individual hull inner side, brackets shall be used in the transverse planes of the cross-deck structure stiffeners, for the connection of those deck stiffeners which are the closest to the inner side, to the inner side stiffener which is the closest to the deck.

25.4.2.10 The strength of cross-deck structure without bottom plating subjected to transverse bending or torsion of catamaran may be ensured by means of several reinforced transverse girders.

In that case, bulkheads, divisions or reinforced frames shall be arranged in the individual hulls coplanarly with such girders.

In way of connection of the reinforced girder face plates to the individual hull sides, horizontal brackets shall be fitted as shown in Fig. 25.4.2.6.

25.5 Hull Structure Strength

25.5.1 Minimum Thicknesses of Structural Members

25.5.1.1 Minimum thicknesses of structural members shall be determined in accordance with the requirements specified in sub-chapter 13.2 considering each individual hull as the hull of single-hull ship and the cross-deck structure as the double bottom of the ship.

25.5.2 Strength and Buckling Strength of Plating and Plating Stiffeners

25.5.2.1 To determine the required plating thickness and the required sectional modulus of the plating stiffeners and to assess their buckling stability, the requirements specified in Chapter 13 shall be applied.

For this purpose, coefficient f shall be determined in accordance with formula 13.1.2 using the values of M_s , M_w and W_1 determined in accordance with 25.6.8.

Design loads shall be assumed in accordance with sub-chapter 25.6.

Corrosion additions shall be taken in accordance with sub-chapter 2.5.

25.5.2.2 The plating and stiffeners of bottom and sides of individual hulls in the forebody shall also be checked in the conditions of slamming pressure p_u determined in accordance with 25.6.3 and 25.6.4 and in compliance with the requirements specified in paragraphs 6.7.2, 6.7.3, 7.4.2 and 7.4.3.

25.5.2.3 Scantlings of the cross-deck structure bottom plating and stiffeners shall be determined in accordance with the requirements specified in paragraphs 6.7.2 and 6.7.3 assuming slamming pressure p_u determined in accordance with 25.6.5.

25.5.3 Strength of Primary Supporting Members' System

25.5.3.1 The strength of the system of primary supporting members in individual hulls and cross-deck structure shall be assessed in accordance with the requirements specified in sub-chapters from 14.1 to 14.5, for local loads determined in accordance with 25.6.2, 25.6.6 and 25.6.7, taking into account the general bending stress in the vertical plane determined in accordance with the requirements specified in paragraphs 25.5.4 and 15.1.1.2.

Additionally, the requirements specified in paragraphs 6.7.4 – for individual hull members and cross-deck structure primary supporting members, as well as 7.4.4 – for side structural primary supporting members shall be applied assuming the slamming pressure p_u determined in accordance with paragraphs 25.6.3, 25.6.5 and 25.6.4.

25.5.3.2 The strength of the system of primary supporting members in individual hulls and cross-deck structure is also to be checked in accordance with the requirements specified in paragraphs 25.5.5 to 25.5.7.

25.5.4 Longitudinal Strength

25.5.4.1 The strength of each individual hull in the conditions of general bending is subject to assessment in accordance with the requirements specified in Chapter 15 where the bending moment and shear force shall be taken in accordance with 25.6.8.

25.5.4.2 Each individual hull shall be considered as a single-hull ship.

While determining the single hull sectional modulus, continuous members of the cross-deck structure in the area shown in Fig. 25.5.4.2 may be considered.

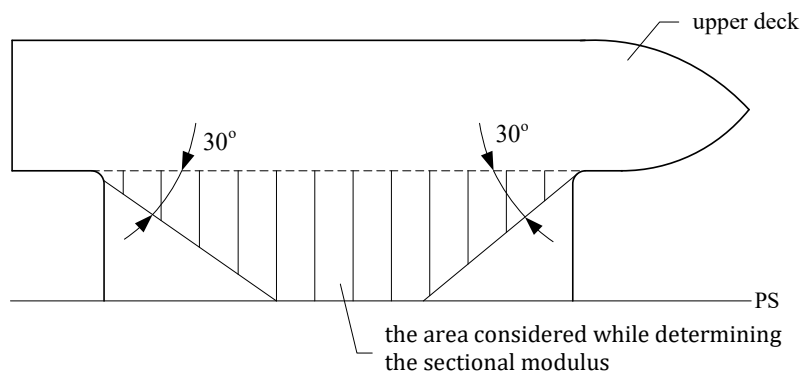

Fig. 25.5.4.2. Cross-deck structure area considered while determining the sectional modulus

25.5.4.3 Application of shell-and-beam FEM model for the entire hull of catamaran (including the superstructure or deckhouse) is subject to PRS consideration in each particular case.

25.5.5 Cross-deck Structure Transverse Bending

25.5.5.1 The strength of cross-deck structure members, deck, sides and bulkheads of individual hulls in way of the cross-deck structure as well as superstructure or deckhouse covering the cross-deck structure is subject to assessment.

25.5.5.2 It is recommended that strength analysis FEM model covering the entire catamaran hull including the superstructure or deckhouse be applied. The FEM model shall be developed in accordance with the general principles specified in sub-chapter 14.4.

25.5.5.3 Bending moment $M_p = M_{ps} + M_{pw}$ (M_{ps} , M_{pw} – are defined in 25.6.9) may be applied to the FEM model as continuous loads acting horizontally coplanar with the decks and at the level of individual hulls' bottom so that the load of each individual hull be equivalent to the load by a force couple of moment M_p .

The stress in the region adjacent to the loads so applied is not subject to assessment.

25.5.5.4 Allowable stress values specified in 14.5.3 with neglected stress due to general bending of ship apply.

25.5.6 Cross-deck Structure Torsion around Transverse Axis

25.5.6.1 The scope of structure to be assessed is as specified in 25.5.5.1. It is recommended that a FEM model developed in accordance with 25.5.5.2 be applied.

25.5.6.2 Torque M_{sk} of the value determined in accordance with 25.6.10 may be applied in the form of the system of vertical force couples coplanar with the centre planes of individual hulls (see Fig. 25.5.6.2).

The above mentioned forces shall be so taken that the maximum value of the moment causing torsion of catamaran around its longitudinal axis does not exceed the value M_t defined in 25.6.11.1.

The stress in the region where the above mentioned loads are applied is not subject to assessment.

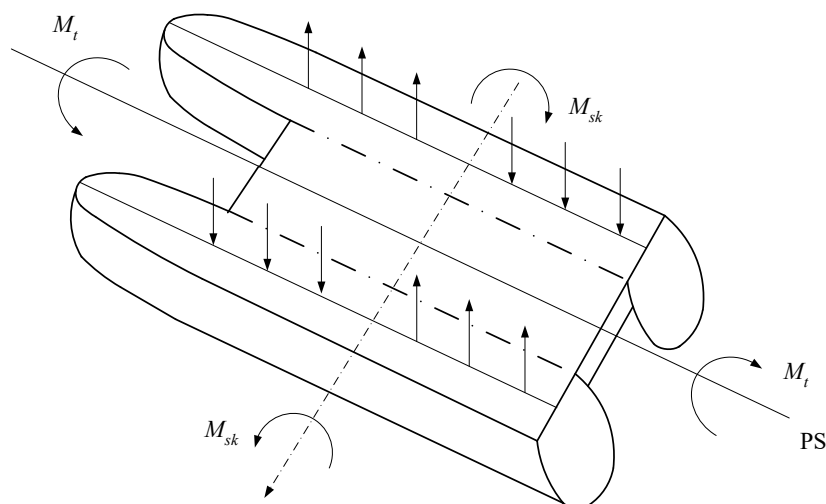

Fig. 25.5.6.2. Force couple system for application of torque M_{sk}

25.5.6.3 Allowable stress values are the same as specified in 25.5.5.4.

25.5.7 Cross-deck Structure Torsion around Longitudinal Axis

25.5.7.1 The scope of assessment, recommendations regarding the FEM model and allowable stress values are as specified in 25.5.6.

25.5.7.2 Torque M_t of the value in the transverse section amidships determined in accordance with 25.6.11.1 may be applied as a system of vertical force couples coplanar with individual hull centre planes. The vertical force couples are roughly evenly distributed along the individual hulls.

The values of such forces shall be so taken that the value of torque M_t in the midship section of catamaran is obtained and the moment causing the cross-deck structure torsion around the transverse axis does not exceed the value of M_{sk} defined in 25.6.10.1

25.5.8 Cross-deck Structure Shearing

25.5.8.1 The values of average shear stress in transverse divisions and bulkheads of the cross-deck structure (see 25.6.9.3) and the associated normal stress and equivalent stress shall not exceed the allowable stress values specified in 14.5.3.1. The method of calculation of the above mentioned stresses is specified in 25.5.8.2.

25.5.8.2 Average shear stress (see 25.5.8.1) shall be determined in accordance with the following formula:

$$\tau = \frac{Q_{pw}}{10 \cdot A_p} \quad [\text{MPa}] \quad (25.5.8.2-1)$$

where:

Q_{pw} – transverse shear force determined using formula 25.6.9.3-1, [kN],

A_p – the total of effective cross-section areas of transverse divisions and bulkheads in cross-deck structure (see 3.2.3) situated in any plane parallel with the centre plane, [cm²].

Normal stress shall be determined in accordance with the following formula:

$$\sigma = \frac{1000M'_{pw}}{W} \text{ [MPa]} \quad (25.5.8.2-2)$$

where:

M'_{pw} – bending moment determined in accordance with formula 25.6.9.3-2, [kNm],

W – sectional modulus of the cross-deck structure cross-section made in a plane parallel with the centre plane in way of the connection to the individual hull side, [cm³].

Equivalent stress shall be determined in accordance with the following formula:

$$\sigma_{zr} = \sqrt{\sigma^2 + 3\tau^2} \text{ [MPa]} \quad (25.5.8.2-3)$$

where:

τ – shear stress to be determined in accordance with formula 25.5.8.2-1, [MPa],

σ – normal stress to be determined in accordance with formula 25.5.8.2-2, [MPa].

25.5.9 Strength of Cross-deck Structure Subjected to Load Combination

25.5.9.1 The strength of the system of primary supporting members of the cross-deck structure, individual hulls in way of the cross-deck structure as well as superstructure/deckhouse shall be checked for the following simultaneous loads:

- 80% of the bending moment required in 25.5.4 and 60% of torque M_t defined in 25.5.7,
- 60% of the bending moment required in 25.5.4 and 80% of torque M_t defined in 25.5.7,
- 70% of the bending moment defined in 25.5.5 and 100% of moment M_{sk} defined in 25.5.6,
- 100% of the bending moment M_p defined in 25.5.5 and 70% of moment M_{sk} defined in 25.5.6.

25.5.9.2 The same FEM model as that mentioned in paragraphs 25.5.4 to 25.5.7 may be applied.

The same allowable stress values as those determined in paragraph 25.5.5.4 shall be taken.

25.5.10 Strength of Cross-deck Structure in Dry-docking Conditions

25.5.10.1 The strength of primary supporting members shall be determined in accordance with 25.5.6 in the scope as specified in paragraph 25.5.5.1.

The moment causing cross-deck structure torsion around the transverse axis shall be determined in accordance with the following formula (see also Fig. 25.5.10.2):

$$M_{sk} = \frac{1}{2} g D_d e \text{ [kNm]} \quad (25.5.10.1)$$

where:

D_d – displacement of catamaran ready for dry-docking, [t],

e – dimension defined in Fig. 25.5.10.1, [m].

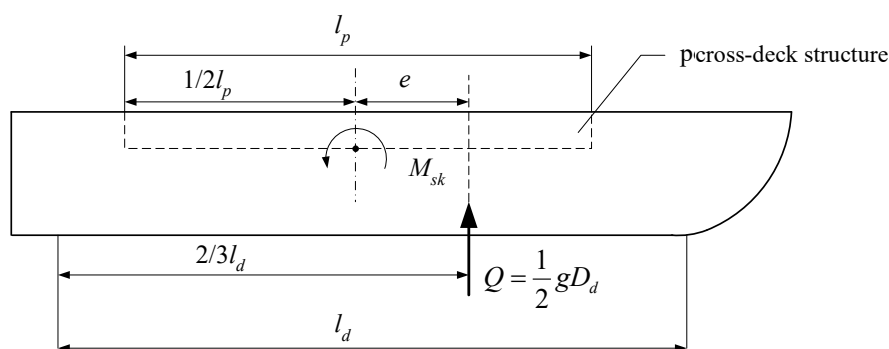
Fig. 25.5.10.1. M_{sk} in dry-docking conditions

In Fig. 25.5.10.1, l_p represents the length of cross-deck structure while l_d – the length of individual hull keel segment supported by keel blocks.

25.5.10.2 Equivalent stress in the primary supporting members determined by means of FEM model developed in accordance with the general principles defined in paragraph 14.4.2 shall not exceed the material yield point.

25.6 Design Loads

25.6.1 General

25.6.1.1 In sub-chapter 25.6, local loads are determined acting on the construction to be used for the assessment of the strength of plating, plating stiffeners and primary supporting members in accordance with the requirements specified in paragraphs 25.5.2 and 25.5.3 as well as general loads to be used in the construction strength calculation in accordance with the requirements specified in paragraphs from 25.5.4 to 25.5.8.

25.6.2 External Pressures

25.6.2.1 Amplitudes of ship motions and accelerations shall be determined in accordance with the requirements specified in sub-chapters 17.3 and 17.4 – except for pitch amplitude θ_A and roll amplitude ϕ_A whose values are as follows:

$$\Theta_A = 0.15 \text{ rad} \quad (25.6.2.1-1)$$

$$\Phi_A = 0.25 \text{ rad} \quad (25.6.2.1-2)$$

The values of L_0 , B and T for an individual hull shall be taken for calculations.

25.6.2.2 The values of pressure acting on outer and inner sides of individual hulls as well as on the upper deck shall be determined in accordance with paragraph 16.2.2.

The values of pressure acting on the cross-deck structure bottom shall be assumed the same as for the inner side in way of its connection to the cross-deck structure.

The values of slamming pressure due to slamming determined in accordance with 25.6.5 also apply to the cross-deck structure.

The design load of superstructure walls shall be determined in accordance with the requirements specified in sub-chapter 10.4.

25.6.2.3 For catamarans of restricted service, loads may be reduced in accordance with 25.1.1.2.

25.6.3 Slamming Loads on Individual Hull Bottoms

25.6.3.1 Design slamming load acting on the individual hull bottom in the forebody shall be determined in accordance with the following formula:

$$p_u = \frac{5L_0}{tg\alpha} \left(1 - 20 \frac{T_m}{L_0} \right) \text{ [kPa]} \quad (25.6.3.1)$$

where:

T_m – minimum value of draught at *FP* in the expected loading conditions, [m].

T_m shall be determined as a vertical distance from the waterline to the lowest point of frame section;

α – rake angle related to the bottom in the relevant frame section; where flat portions of bottom do not exist, α shall be determined in accordance with Fig. 25.6.3.1.

The value of α taken for calculations need not be lesser than 10° and shall not exceed 30° .

If p_u determined in accordance with formula 25.6.3.1 takes a negative value, then $p_u = 0$ shall be taken.

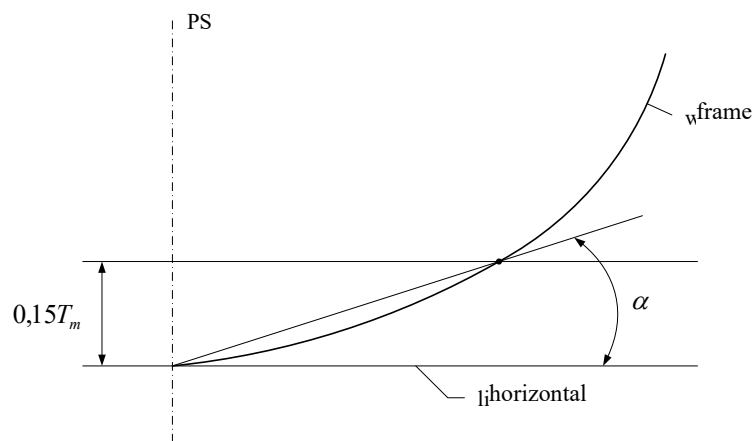

Fig. 25.6.3.1. Determining rake angle α

25.6.3.2 Pressure p_u determined in accordance with formula 25.6.3.1 exerts load on the bottom in the region below the upper point of the bilge turn or below the hull chine and not higher than $0.25T_m$ above the level of the lowest frame point in the centre plane.

25.6.3.3 Pressure p_u determined in accordance with 25.6.3.1 shall be applied in the bottom region $0.35L_0$ aft of *FP*.

In the region from $0.35L_0$ to $0.5L_0$ aft of *FP*, the slamming pressure reduces linearly versus x , from the value determined above to zero.

25.6.4 Slamming Load on Individual Hull Sides

25.6.4.1 Slamming pressure on the shell plating in the individual hull forebody, in the region $0.3L_0$ aft of *FP*, shall be determined in accordance with paragraph 7.4.5 considering each individual hull as the hull of single-hull ship.

This slamming pressure exerts the load on the shell plating above the region subjected to pressure on the bottom p_u , defined in 25.6.3.2, up to the level of upper deck (or cross-deck structure) or the lower boundary of the region where the sides are vertical.

25.6.5 Slamming Load on Cross-deck Structure Bottom

25.6.5.1 Slamming pressure on the cross-deck structure bottom shall be determined in accordance with the following formula:

$$p_u = c(x) \cdot 750 \left(1 - \frac{h_0}{h_L} \right) \text{ [kPa]} \quad (25.6.5.1)$$

where:

$c(x)$ – coefficient depending on coordinate x whose diagram is shown in Fig. 25.6.5.1;

h_0 – vertical distance between the cross-deck structure bottom point where p_u is determined and the maximum waterline of individual hulls, [m];

h_L – the minimum value of the distance between the cross-deck structure bottom and the waterline at which no slamming occurs, [m]; the values of h_L versus L_0 are specified in Table 25.6.5.1; for intermediate values of L_0 , linear interpolation shall be applied.

If p_u determined in accordance with formula 25.6.5.1 takes a negative value, then $p_u = 0$ shall be taken.

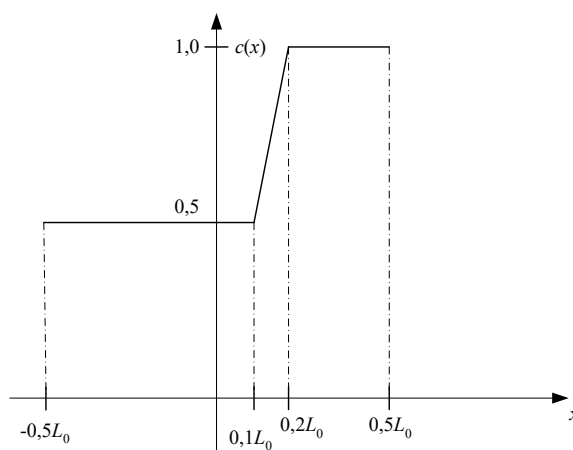

Fig. 25.6.5.1. Values of $c(x)$

Table 25.6.5.1
Values of h_L

L_0 [m]	h_L [m]
25	1.54
30	1.82
40	2.36
50	2.86
60	3.32
70	3.75
80	4.15
90	4.51

25.6.6 Pressure of Liquid in Tanks

25.6.6.1 In the strength analysis of catamaran hull construction, pressures p_6 , p_7 and p_8 determined in accordance with the requirements specified in sub-chapter 16.3.2 shall be taken into account.

For this purpose, acceleration a_v shall be determined in accordance with the requirements specified in paragraph 25.6.2.1.

25.6.7 Cargo Loads

25.6.7.1 Cargo loads acting on the catamaran hull construction shall be determined in accordance with the requirements specified in sub-chapter 16.4 and also those specified in paragraph 25.6.2.1.

25.6.8 Bending Moments and Shear Forces in Conditions of Catamaran Bending in Vertical Plane

25.6.8.1 Moment, M_s , bending the catamaran hull in still water shall be determined in accordance with the principles specified in sub-chapter 15.4.4, substituting total breadth of both individual hulls B_s for B .

25.6.8.2 The value of vertical wave bending moment in the entire hull of catamaran, M_w , in the region $-0.1L_0 < x < 0.15L_0$, to be taken for calculations shall be determined in accordance with the following formulae:

– in sagging

$$M_w = M_{wu} = -0.11C_w L_0^2 (B - cB_p) (\delta + 0.7) \quad [\text{kNm}] \quad (25.6.8.2-1)$$

– in hogging

$$M_w = M_{ww} = 0.19C_w L_0^2 (B - cB_p) \delta \quad [\text{kNm}] \quad (25.6.8.2-2)$$

where:

L_0, B, B_p, δ – as defined in 25.1.2,

C_w – to be determined in accordance with 17.2.2,

c – coefficient taking values specified in Table 25.6.8.2, depending on z_p, T and C_w (see 25.1.2).

Table 25.6.8.2
Values of coefficient c

$\frac{C_w}{T}$	$\frac{z_p}{T}$					
	≤ 1.5	1.75	2.0	2.25	2.5	≥ 3.0
≤ 1.5	0.29	0.36	0.43	0.50	0.57	0.71
2.0	0.22	0.28	0.33	0.39	0.44	0.56
2.5	0.18	0.23	0.27	0.32	0.36	0.45
3.0	0.15	0.19	0.23	0.27	0.31	0.38
3.5	0.13	0.17	0.20	0.23	0.27	0.33
4.0	0.12	0.15	0.18	0.21	0.24	0.29
≥ 4.5	0.11	0.13	0.16	0.18	0.21	0.26

For intermediate values of ratios C_w/T and z_p/T , coefficient c shall be determined by linear interpolation.

25.6.8.3 Distribution of M_w along the catamaran shall be taken in accordance with 15.5.2.1.

For catamarans of considerably bevelled frames in the forebody above the design waterline, PRS may require to increase M_{wu} by 20%. In that case, the distribution of M_{wu} along the catamaran is as shown in the diagram of k_{wu} in Fig. 15.5.2.2.

25.6.8.4 The value of shear force in the catamaran hull to be taken for calculations shall be determined in accordance with the following formula:



$$Q = k_Q \cdot 5M / L_0 \text{ [kN]} \tag{25.6.8.4}$$

where:

M – combined bending moment taking the greater value of $M_s + |M_{wu}|$ and $M_s + M_{ww}$, [kNm],

k_Q – coefficient taking the following values:

$$k_Q = 0 \text{ for } x = -0.5L_0 \text{ and } x = 0.5L_0$$

$$k_Q = 1.0 \text{ for } -0.35L_0 \leq x \leq 0.35L_0$$

The values of k_Q in the regions $-0.5L_0 < x < -0.35L_0$ and $0.35L_0 < x < 0.5L_0$ vary linearly.

25.6.9 Transverse Bending Moment

25.6.9.1 Transverse moment bending of the cross-deck structure in still water M_{ps} (see Fig. 25.6.9.1) shall be determined in accordance with the transverse distribution of catamaran mass and the maximum value shall be taken for calculations.

The value of M_{ps} taken for the cross-deck structure strength calculations shall not be less than:

$$M_{ps} = 0.125gDB_p \text{ [kNm]} \tag{25.6.9.1}$$

where:

D, B_p – see 25.1.2.

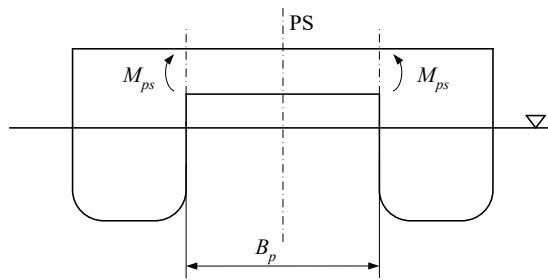

Fig. 25.6.9.1. Transverse bending moment in still water

25.6.9.2 Transverse wave bending moment in still water M_{pw} (see Fig. 25.6.9.2) shall be determined in accordance with the following formula:

$$M_{pw} = 8.4L_0T^2H_p \text{ [kNm]} \tag{25.6.9.2}$$

where:

L_0, T, H_p – see 25.1.2.

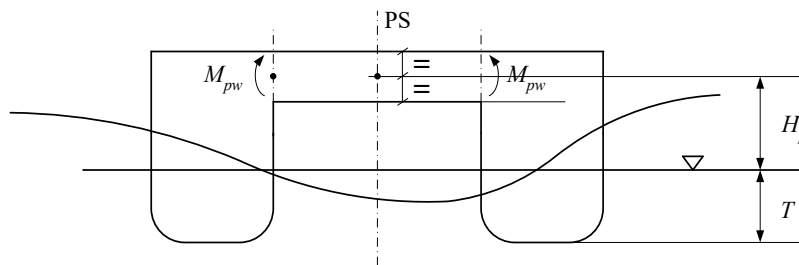

Fig. 25.6.9.2

25.6.9.3 Transverse force shearing the cross-deck structure in the waving conditions Q_{pw} (see Fig. 25.6.9.3) shall be determined in accordance with the following formula:

$$Q_{pw} = 2L_0T^2 \text{ [kN]} \tag{25.6.9.3-1}$$

Bending moments, M'_{pw} , associated with force Q_{pw} (see Fig. 25.6.9.3) shall be determined in accordance with the following formula:

$$M'_{pw} = 0.5Q_{pw} \cdot B_p \quad [\text{kNm}] \quad (25.6.9.3-2)$$

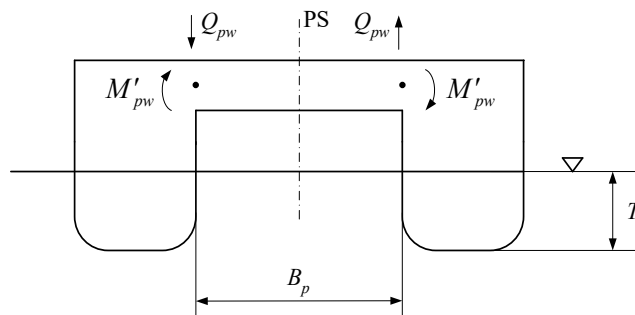

Fig. 25.6.9.3

25.6.10 Moment Causing Cross-deck Structure Torsion around Transverse Axis

25.6.10.1 Moment M_{sk} causing the cross-deck structure torsion around the transverse axis (see Fig. 25.6.10.1) shall be determined in accordance with the following formula:

$$M_{sk} = M_{sw} + M_{ss} \quad [\text{kNm}] \quad (25.6.10.1-1)$$

where:

M_{sw} – wave torque to be determined in accordance with the following formula:

$$M_{sw} = 2.5L_0^2 B_1 \quad [\text{kNm}] \quad (25.6.10.1-2)$$

M_{ss} – torque in still water [kNm].

The maximum value of M_{ss} determined for the practicable methods of distribution of the mass of cargoes, stores and ballast, however not less than $0.5M_{sw}$, shall be taken for the cross-deck structure strength calculations.

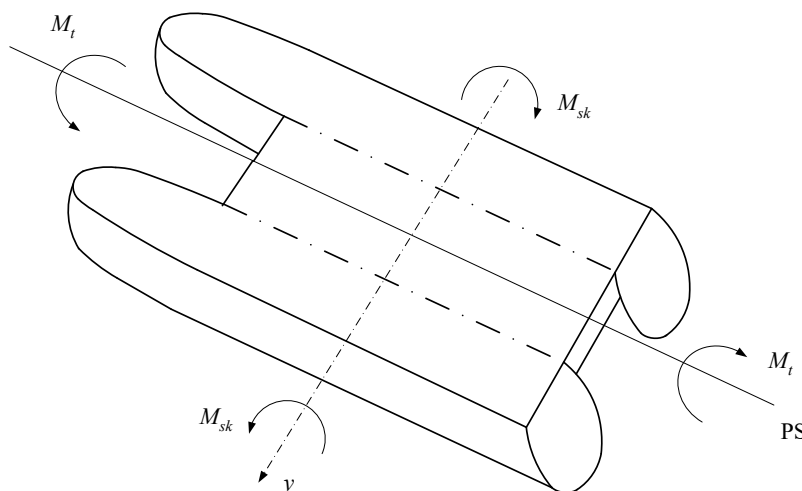

Fig. 25.6.10.1

25.6.11 Moment Causing Cross-deck Structure Torsion around Longitudinal Axis

25.6.11.1 The midship value of moment M_t causing the cross-deck structure torsion around the longitudinal axis (see Fig. 25.6.10.1) shall be determined in accordance with the following formula:

$$M_t = 0.25gD(B - B_1) \text{ [kNm]} \quad (25.6.11.1)$$

25.6.11.2 Linear distribution $M_t(x)$ shall be assumed in the segments between the midship section and the fore and after perpendiculars where $M_t(x) = 0$.

26 ICE AND SPECIAL STRENGTHENINGS

26.1 General

26.1.1 Application

The requirements for additional class notation are given in *Publication 122/P – Requirements for ice Baltic class and Polar class for ships under PRS supervision*. Additionally ships operating in Polar Waters shall fulfil the requirements specified in *Chapter 3 – Ship Structure* and *Chapter 4 of Part I-B – Additional guidance to Chapter 3 (Ship Structure) of International Code for Ships Operating in Polar Waters (Polar Code) (resolution MSC.385(94))*.

26.1.1.1 The requirements specified in sub-chapter 26.2 apply to ships with cargo holds adapted for cargo handling operations with the use of grabs.

26.1.1.2 The requirements specified in sub-chapter 26.3 apply to ships lying aground during loading operations.

26.1.1.3 The requirements specified in the present Chapter shall be regarded as supplementary to the basic requirements set forth in Chapters 1,17.

26.2 Strengthenings in Ships Unloaded with Grabs

26.2.1 The thickness of the inner bottom plating and of sloped bulkhead plating in holds, as well as the plating of vertical bulkhead at least 1.5 m above the inner bottom shall not be less than that determined in accordance with the following formula:

$$t = 11.5 \left(\frac{s+0.8}{\sqrt{k}} \right) + t_k \quad [\text{mm}] \quad (26.2.1)$$

26.2.2 The thickness of the cargo hatch coamings in the upper deck shall not be less than 15 mm.

26.3 Strengthenings in Ships Lying Aground during Loading Operations

26.3.1 Double bottom stiffened transversely shall be provided with plate floors at each frame and additional side stringers over the full length of the double bottom. The spacing between those stringers shall not exceed 2 m. Side stringers in longitudinally stiffened double bottom shall be fitted instead of bottom longitudinals. Floors in such double bottom shall be arranged over its full length at half spacings as compared with those determined in 6.2.6.

26.3.2 In a single bottom, the plating thickness of side stringers and floors shall be increased by 10%.

The location of side stringers and floors shall comply with the requirements for the double bottom.

27 ADDITIONAL REQUIREMENTS FOR SHIPS WHICH OCCASIONALLY CARRY DRY CARGOES IN BULK AND ARE NOT CLASSIFIED AS BULK CARRIERS

27.1 Application

The requirements specified in Chapter 27 apply to ships assigned an additional mark **DRY CARGO SHIP** in the symbol of class, which satisfy the following conditions:

- structural arrangement is different form that described in sub-chapter 20.1.2;
- the ships occasionally carry dry cargoes in bulk (other than those specified in 20.1.1.2).

The requirements for ships of double-side skin construction are specified in sub-chapter 27.2 and for ships of single-side skin – in sub-chapter 27.3.

27.2 Ship of Double-side Skin Construction

The ship is permitted to occasionally carry dry cargoes in bulk, provided:

- .1 the freeboard assigned is type B (without reduced freeboard);
- .2 double-side skin construction is according to 20.11.2 and 20.11.3;
- .3 the ship is provided with loading instrument being in compliance with the requirements for bulk carriers (see 15.13 and *SOLAS-XII/11*);
- .4 dedicated seawater-ballast tanks in ships and double skin spaces arranged in ship of 150 m in length and upwards have been coated with protective coating according to 2.4.1;
- .5 water level detectors with warning devices and dewatering/pumping arrangements according to the requirements specified in 22.9, *Part VI – Machinery Installations and Refrigerating Plants* have been applied.

27.3 Ship of Single-side Skin Construction

The ship is permitted to occasionally carry dry cargoes in bulk, provided:

- .1 the length of the ship is less than 100 m;
- .2 the freeboard assigned is type B (without reduced freeboard);
- .3 the ship is provided with loading instrument being in compliance with the requirements for bulk carriers (see 15.13 and *SOLAS-XII/11*);
- .4 dedicated seawater-ballast tanks have been coated with protective coating;
- .5 water level detectors with warning devices and dewatering/pumping arrangements according to the requirements specified in 22.9, *Part VI – Machinery Installations and Refrigerating Plants* have been applied.

28 ADDITIONAL REQUIREMENTS FOR ENERGY EFFICIENT SHIPS

28.1 Application

The requirements of this chapter apply to new ships and those subjected to a major conversion, of 400 GT and more, engaged in the international trade, described in Regulation 21 of Annex VI to the *MARPOL Convention*, according to definitions given in Regulation 2.23 and 2.24 of Annex VI to the *MARPOL Convention*.

28.2 Required Documentation

The scope of documentation at each stage and the requirements are described in Guidelines on Survey and Certification of the Energy Efficiency Design Index (EEDI) and in First Industry Guidelines for Calculation and Verification of the Energy Efficiency Design Index (EEDI), both contained in *Publication 103/P*.

Prior to the commencement of a hull construction or conversion and in their course, documentation required at subsequent stages of designing, including that elaborated after sea trials, shall be submitted to the PRS HQ for review and approval.

28.3 Additional Mark in the Symbol of Class

Ships whose attained energy efficiency design index proves to be smaller than the required EEDI (calculated for that specific period of time) can be given an additional mark in the symbol of class: **ECO EF** according to *Part I – Classification Regulations* and *Publication 106/P – Eco Class Rules*.

29 OIL RECOVERY VESSELS

29.1 General

29.1.1 Application

The requirements of this Chapter apply to the oil recovery vessels (ships intended for fighting chemical pollution). The below requirements shall be considered as supplementary to basic requirements contained in Chapters 1 to 17.

29.1.2 Classification

The ship complying with requirements of this Chapter may be assigned the following marks in the symbol of class:

- .1 ships intended for fighting oil spillage:

OIL RECOVERY VESSEL

- .2 ships intended for fighting chemical pollution:

CHEMICAL RECOVERY VESSEL.

29.1.3 General Provisions

29.1.3.1 The ship structure shall be such as to permit navigation in oily waters and in hazardous atmospheres. It shall be resistant to dangerous or corrosive substances or those with a flash point not exceeding 60°C.

29.1.3.2 The ship's hull shall be generally constructed of steel. Hull of vessels designed with restricted function of spillage removal may be constructed of materials other than steel, which shall be each time approved by PRS. For restrictions as regards carriage of some hazardous substances or operation in hazardous atmosphere, the ship shall receive the list of substances permitted to be carried onboard as an Appendix to Certificate of Class.

29.2 Definitions

29.2.1 Additionally to the definitions of hazardous zone, contained in subchapter 1.2 of *Part I* of the *Rules*, for the purpose of this Chapter the specification of ship's areas, normally covered by the considered zone (see Table 29.2.1) applies.

Table 29.2.1

Zone 0	
1	cargo tanks for the storage of hazardous substances and the interiors of pipelines and vessels belonging to the cargo containment system;
2	spaces extending to a height of 1 m above the load waterline in ballast condition. Note: For ships defined in 29.1.2.2, all space surrounding the ship up to the height of upper navigation lights shall be considered zone 0.
Zone 1	
1	cofferdams and other spaces adjacent to cargo tanks;
2	cargo pump rooms;
3	enclosed or semi-enclosed spaces directly above cargo tanks or with boundaries coplanar with cargo tank bulkheads;
4	stowage spaces for cargo hoses and oil recovery equipment;
5	holds for hazardous substances;

6	spaces on the open deck including semi-enclosed spaces within a spherical radius of 3 m of tank openings and openings to pump rooms, holds or cofferdams (e.g. cargo tank hatches, inspection holes, ventilation openings, access openings);
Note: For ships defined in 29.1.2.2, all space of the open deck shall be considered zone 1.	
7	spaces on the open deck above the zone 0 over the full width and length of the ship up to 3.0 m above the uppermost continuous deck. On ships whose uppermost continuous deck is Zone 0, Zone 1 extends up to 3.0 m above Zone 0 (it does not apply to the ships defined in 29.1.2.2).;
8	spaces without overpressure ventilation which can be entered directly (without air lock) from Zone 1 hazardous area or which have openings to Zone 1;
9	enclosed or semi-enclosed spaces containing pipelines belonging to the cargo containment system.
Zone 2	
1	spaces above Zone 1 over the full width and length of the ship;
2	spaces without overpressure ventilation which can be entered directly (without air lock) from Zone 2 hazardous area or which have openings to Zone 2

29.2.2 *Cargo space*– that part of the ship which contains all compartments and tanks, including slop tanks, intended for the carriage of packaged liquid or solid substances or of bulk cargo. Additionally, the cargo space includes cargo pump rooms, ballast pump rooms, cofferdams, cargo tanks or voids adjacent to cargo tanks or slop tanks and also deck areas throughout the entire length and breadth of the ship, over the above-mentioned spaces.

In accordance with the definition, all tanks used for timely storage of substances, such as settling tanks, shall be considered cargo/slop tanks.

29.3 Space Division

29.3.1 Design of division into holds shall take into account their intended cargo, maximum expected mass of cargo and the kind of packaging required for those substances, in accordance with Chapter 4 of *IMDG Code*.

29.3.2 Arrangement of tanks for hazardous substances within the ship's hull shall be in accordance with requirements for chemical carriers of type 1, as given in paragraph 2.6.1 of *IBC Code*. Additional requirements for segregation of substances, determining the number of types and purpose of tanks are contained in subchapter 3.1 and Chapters 4 and 15 of *IBC Code*.

29.3.3 The accommodation spaces, service spaces, machinery compartment and control stations shall be so located in relation to cargo space and tanks as to comply with requirements of 3.2.1 of *IBC Code*.

29.3.4 A dedicated operations center (definition see subchapter 1.2 of the *Rules*, Part I) shall be provided onboard ship.

29.3.5 All entries to ship citadel shall be provided with an air lock.

29.4 Tank Structure

29.4.1 Materials to be used for the structure of hazardous substances tanks shall comply with requirements of Chapter 6 of *IBC Code*.

29.4.2 The structure of independent tanks and their supports in the hull shall comply with the requirements of Chapter 6.7 of *IMDG Code*.

30 BALLAST WATER EXCHANGE AT SEA

30.1 General

The following methods of ballast water exchange at sea have been evaluated and are recognized by IMO:

- sequential method, process by which a ballast tank intended for the carriage of water ballast is first emptied and then refilled with replacement, ballast water to achieve at least a 96% volumetric exchange;
- flow-through method, a process by which replacement ballast water is pumped into a ballast tank intended for the carriage of water ballast, allowing water to flow through overflow or other arrangements. At least three times the tank volume shall be pumped through the tank.

30.2 Ballast Water Management

After the ballast water exchange methods for a ship have been determined, the relevant sequencing or pump-through operational information shall be documented, together with safety conditions, in the Ballast Water Management Plan.

The ship's loading conditions for the ballast water exchange methods shall be developed and results of calculations submitted to PRS to show that the loading conditions satisfy the applicable requirements for ballast capacity, trim stability, longitudinal strength and local strength. These conditions shall be submitted for approval.

Resolution MEPC.149(55) as well as Resolution MEPC.288(71) shall be fulfilled.

SUPPLEMENT RETROACTIVE REQUIREMENTS

1 GENERAL

1.1 Application

1.1.1 The requirements specified in the present Supplement apply to existing ships as described, in detail, in subchapters 2.1 to 2.6, below.

1.1.2 The scope of documentation subject to PRS consideration and approval shall be specified by PRS in each particular case.

1.2 Implementation Timetable for Existing Bulk Carriers

1.2.1 The requirements, specified in 2.1 and 2.2 below, shall be applied in conjunction with the damage stability requirements specified in 5.3.4.2 of Part IV of the *Rules for the Classification and Construction of Sea-going Ships*.

1.2.2 Compliance with the above-mentioned requirements is required:

- a) for ships which were 20 years of age or more on 1 July 1998, by the due date of the first intermediate, or the due date of the first special survey to be held after 1 July 1998, whichever comes first;
- b) for ships which were 15 years of age or more but less than 20 years of age on 1 July 1998, by the due date of the first special survey to be held after 1 July 1998, but not later than 1 July 2002;
- c) for ships which were 10 years of age or more but less than 15 years of age on 1 July 1998, by the due date of the first intermediate, or the due date of the first special survey to be held after the date on which the ship reaches 15 years of age but not later than the date on which the ship reaches 17 years of age;
- d) for ships which were 5 years of age or more but less than 10 years of age on 1 July 1998, by the due date, after 1 July 2003, of the first intermediate or the first special survey after the date on which the ship reaches 10 years of age, whichever occurs first;
- e) for ships which were less than 5 years of age on 1 July 1998, by the date on which the ship reaches 10 years of age.

1.3 Requirements for bulk carriers not being capable of complying with strength criteria for bulkheads between cargo holds Nos. 1 and 2 and for double bottom in cargo hold No. 1, in flooding conditions

In accordance with the requirements of SOLAS XII/9, for bulk carriers constructed before 1 July 1999 which have been constructed with an insufficient number of transverse watertight bulkheads to satisfy the stability criteria for hold No.1 in flooding condition, given in SOLAS XII regulation 4.3, the relaxation may be allowed from the requirements concerning strength of corrugated bulkhead between holds No. 1 and No.2 (acc. to 2.1) and the strength of double bottom in hold No. 1 (acc. to 2.2), on condition that they shall comply with the following requirements:

- a) for cargo hold No. 1, the inspections prescribed for the annual survey in the enhanced programme of inspections;
- b) provision of detection and alarm systems for the water in cargo hold and in cargo conveyor tunnel, in damage flooding conditions of the spaces;
- c) provision of a document with detailed information on specific cargo hold flooding scenarios and detailed instructions on evacuation preparedness in emergency.

Detailed requirements for the method of fulfilling the above requirements (a) to (c) are specified in SOLAS XII/9 and in the interpretation of IACS SC154,

2 REQUIREMENTS FOR EXISTING BULK CARRIERS

2.1 Evaluation of Scantlings of Transverse Watertight Corrugated Bulkhead between Cargo Holds No. 1 and No. 2 with Cargo Hold No. 1 Flooded

2.1.1 Application and Definitions

The requirements specified in the present Section apply to all bulk carriers of length $L_0 \geq 150$ m, in the foremost hold, intended to carry solid bulk cargoes having a density of 1.78 t/m^3 , or above, with single deck, topside tanks and hopper tanks, fitted with vertically corrugated transverse watertight bulkheads between cargo holds No. 1 and 2 where:

- .1 the foremost hold is bounded by the side shell only for ships which were contracted for construction prior to 1 July 1998, and have not been constructed in accordance with the requirements specified in sub-chapter 20.7.
- .2 the foremost hold is double side skin construction of less than 760 mm breadth measured perpendicular to the side shell in ships, the keels of which were laid, or which were at a similar stage of construction, before 1 July 1999 and have not been constructed in accordance with the requirements specified in sub-chapter 20.7.

The net scantlings of the transverse bulkhead between cargo holds No. 1 and No. 2 shall be calculated using the loads given in sub-chapter 2.1.2, the bending moment and shear force given in sub-chapter 2.1.3 and the strength criteria given in sub-chapter 2.1.4.

Where necessary, steel renewal and/or reinforcements are required as per sub-chapter 2.1.6.

In these requirements, homogeneous loading condition means a loading condition in which the ratio between the highest and the lowest filling ratio, evaluated for the two foremost cargo holds, does not exceed 1.20, to be corrected for different cargo densities.

2.1.2 Load Model

2.1.2.1 General

The loads to be considered as acting on the bulkhead are those given by the combination of the cargo loads with those induced by the flooding of cargo hold No.1.

The most severe combinations of cargo induced loads and flooding loads shall be used for the check of the scantlings of the bulkhead, depending on the loading conditions included in the loading manual:

- homogeneous loading conditions;
- non homogeneous loading conditions.

Non homogeneous part loading conditions associated with multiport loading and unloading operations for homogeneous loading conditions need not to be considered in accordance with these requirements.

2.1.2.2 Bulkhead Corrugation Flooding Head

The flooding head h_f (see Fig. 2.1.2.2) is the distance, [m], measured vertically with the ship in the upright position, from the calculation point to a level located at a distance d_f [m], from the baseline equal to:

a) in general:

– D ;

b) for ships less than 50,000 tonnes deadweight with Type B freeboard:

– $0.95D$,

D being the distance, [m], from the base plane to the freeboard deck at side amidships (see Fig. 2.1.2.2);

- c) for ships to be operated at an assigned load line draught T_r less than the permissible load line draught T , the flooding head defined in a) and b) above may be reduced by $T - T_r$.

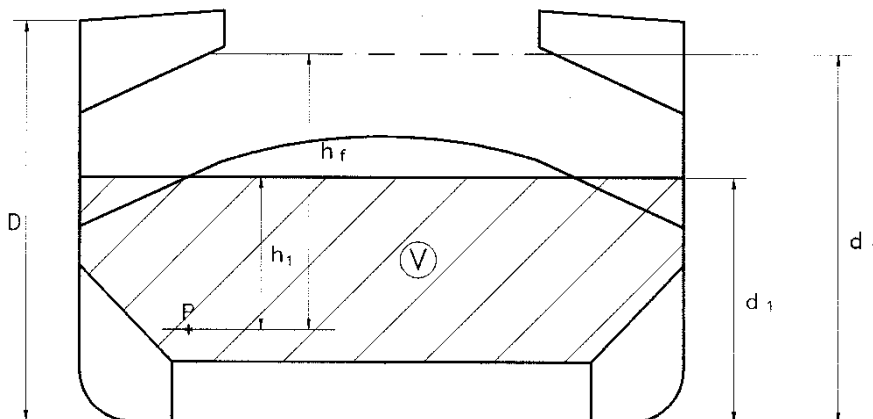

V = Volume of cargo

P = Calculation point

Fig. 2.1.2.2

2.1.2.3 Pressure in the Flooded Hold

2.1.2.3.1 Bulk Cargo Loaded Hold

Two cases shall be considered, depending on the values of d_1 and d_f (see Fig.2.1.2.2), where d_1 is the distance from the baseline, [m], calculated from the formula:

$$d_1 = \frac{M_c}{\rho_c l_c B} + \frac{v_{LS}}{l_c B} + (h_{HT} - h_{DB}) \frac{b_{HT}}{B} + h_{DB}$$

where:

- M_c – mass of cargo [t], in hold No. 1,
- ρ_c – bulk cargo density [t/m³],
- l_c – length of hold No. 1 [m],
- B – ship's breadth amidships [m],
- v_{LS} – volume, [m³], of the bottom stool above the inner bottom,
- h_{HT} – height of the hopper tanks amidships [m], from the baseline,
- h_{DB} – height of the double bottom [m],
- b_{HT} – breadth of the hopper tanks amidships [m].

- a) $d_f \geq d_1$

At each point of the bulkhead located at a distance between d_1 and d_f from the baseline, the pressure $p_{c,f}$, [kPa], is given by:

$$p_{c,f} = \rho g h_1$$

where:

- ρ – sea water density [t/m³],
- $g = 9.81$ m/s², gravity acceleration,
- h_1 – flooding head, see sub-chapter 2.1.2.2.

At each point of the bulkhead located at a distance lower than d_1 from the baseline, the pressure $p_{c,f}$ [kPa], is given by:

$$p_{c,f} = \rho g h_f + [\rho_c - \rho(1 - \text{perm})] g h_1 \tan^2 \gamma$$

where:

ρ, g, h_f – as given above,

ρ_c – bulk cargo density [t/m³],

perm – permeability of cargo, to be taken as 0.3 for ore (corresponding bulk cargo density for iron ore may generally be taken as 3.0 t/m³),

h_1 – vertical distance, [m], from the calculation point to a level located at a distance d_1 , as defined above, from the base plane (see Fig. 2.1.2.2),

$g = 45^\circ - (\phi/2)$,

ϕ – angle of repose of the cargo, in degrees, and may generally be taken as 35° for iron ore.

The force $F_{c,f}$ [kN], acting on a corrugation is given by:

$$F_{c,f} = s_1 \left[\rho g \frac{(d_f - d_1)^2}{2} + \frac{\rho g (d_f - d_1) + (p_{c,f})_{ie}}{2} (d_1 - h_{DB} - h_{LS}) \right]$$

where:

s_1 – spacing of corrugations [m] (see Fig. 2.1.2.3.1-1),

g, d_1, h_{DB} – as given above,

d_f – see sub-chapter 2.1.2.2,

$(p_{c,f})_{ie}$ – pressure, [kPa], at the lower end of the corrugation,

h_{LS} – height of the lower stool [m] from the inner bottom.

b) $d_f < d_1$

At each point of the bulkhead located at a distance between d_f and d_1 from the baseline, the pressure $p_{c,f}$ [kPa], is given by:

$$p_{c,f} = \rho_c g h_1 \tan^2 \gamma$$

where:

ρ_c, g, h_1, γ – as given in a) above.

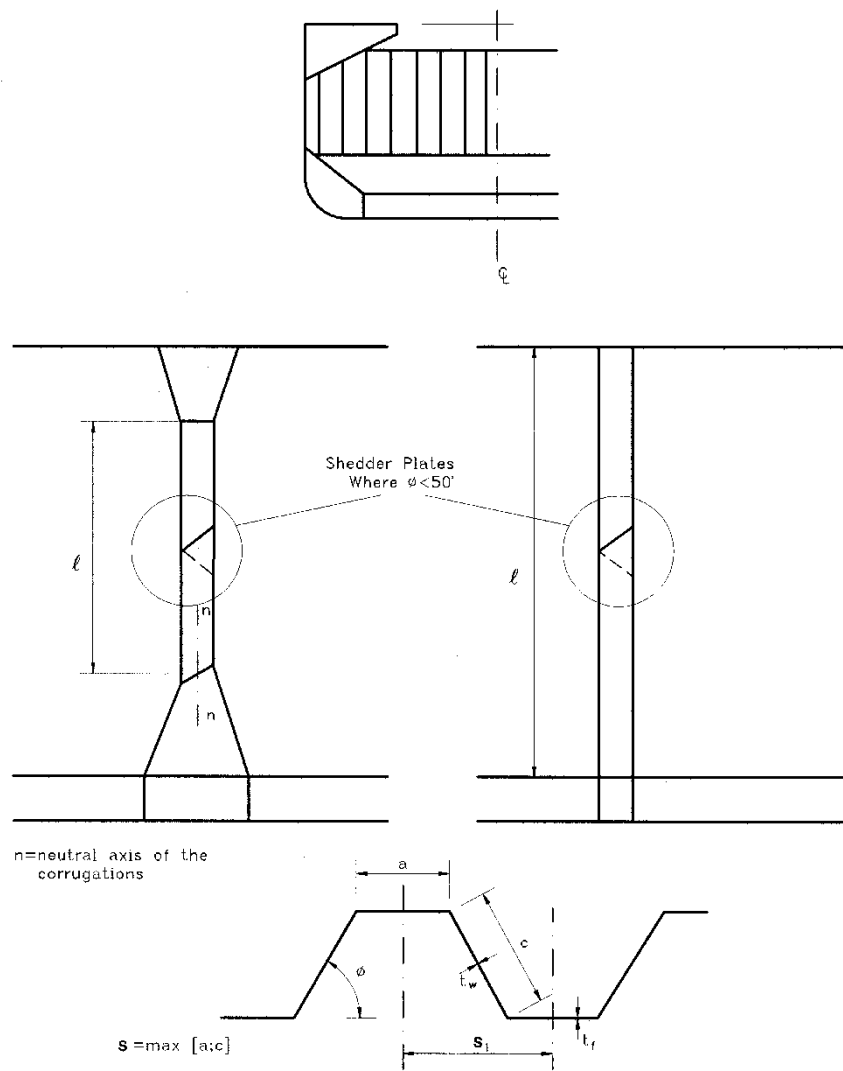

Fig. 2.1.2.3.1-1

At each point of the bulkhead located at a distance lower than d_f from the baseline, the pressure $p_{c,f}$ [kPa], is given by:

$$p_{c,f} = \rho g h_f + [\rho_c h_1 - \rho(1 - \text{perm})h_f] g \tan^2 \gamma$$

where:

$\rho, g, h_f, \rho_c, h_1, \text{perm}, \gamma$ – as given in a) above.

The force $F_{c,f}$ [kN], acting on a corrugation is given by:

$$F_{c,f} = s_1 \left[\rho_c g \frac{(d_1 - d_f)^2}{2} \tan^2 \gamma + \frac{\rho_c g (d_1 - d_f) \tan^2 \gamma + (p_{c,f})_{le}}{2} (d_f - h_{DB} - h_{LS}) \right]$$

where:

$s_1, \rho_c, g, \gamma, (p_{c,f})_{le}, h_{LS}$ – as given in a) above,

d_1, h_{DB} – see paragraph 2.1.2.3.1,

d_f – see sub-chapter 2.1.2.2.

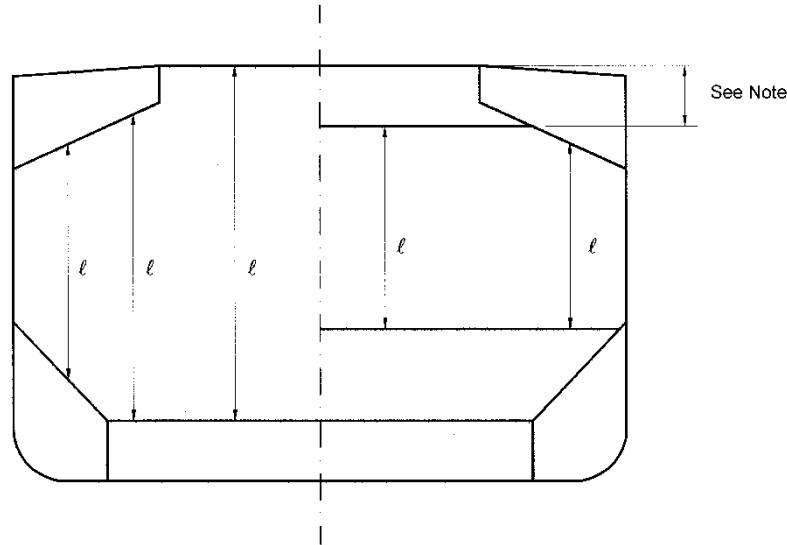

Fig. 2.1.2.3.1-2

Note: For the definition of l , the internal end of the upper stool shall not be taken more than a distance from the deck at the centre line equal to:

- 3 times the depth of corrugations, in general,
- 2 times the depth of corrugations, for rectangular stool.

2.1.2.3.2 Empty Hold

At each point of the bulkhead, the hydrostatic pressure p_f induced by the flooding head h_f shall be considered.

The force F_f [kN], acting on a corrugation is given by:

$$F_f = s_1 \rho g \frac{(d_f - h_{DB} - h_{LS})^2}{2}$$

where:

s_1, ρ, g, h_{LS} – see paragraph 2.1.2.3.1 a),

h_{DB} – see paragraph 2.1.2.3.1,

d_f – see sub-chapter 2.1.2.2.

2.1.2.4 Pressure in the Non-Flooded Bulk Cargo Loaded Hold

At each point of the bulkhead, the pressure p_c [kPa], is given by:

$$p_c = \rho_c g h_1 \tan^2 \gamma$$

where:

ρ_c, g, h_1, γ – see paragraph 2.1.2.3.1 a).

The force F_c [kN], acting on a corrugation is given by:

$$F_c = \rho_c g s_1 \frac{(d_1 - h_{DB} - h_{LS})^2}{2} \tan^2 \gamma$$

where:

$\rho_c, g, s_1, h_{LS}, \gamma$ – see paragraph 2.1.2.3.1 a),

d_1, h_{DB} – see paragraph 2.1.2.3.1.

2.1.2.5 Resultant Pressure

2.1.2.5.1 Homogeneous Loading Conditions

At each point of the bulkhead structures, the resultant pressure p [kPa], to be considered for the scantlings of the bulkhead is given by:

$$p = p_{c,f} - 0.8p_c$$

The resultant force F [kN], acting on a corrugation is given by:

$$F = F_{c,f} - 0.8F_c$$

2.1.2.5.2 Non Homogeneous Loading Conditions

At each point of the bulkhead structures, the resultant pressure p [kPa], to be considered for the scantlings of the bulkhead is given by:

$$p = p_{c,f}$$

The resultant force F [kN], acting on a corrugation is given by:

$$F = F_{c,f}$$

In case hold No.1, in non homogeneous loading conditions, is not allowed to be loaded, the resultant pressure p [kPa], to be considered for the scantlings of the bulkhead is given by:

$$p = p_f$$

and the resultant force F [kN], acting on a corrugation is given by:

$$F = F_f$$

2.1.3 Bending Moment and Shear Force in the Bulkhead Corrugations

The bending moment M and the shear force Q in the bulkhead corrugations are obtained using the formulae specified in sub-chapter 2.1.3.1 and sub-chapter 2.1.3.2. The M and Q values shall be used for the checks in sub-chapter 2.1.4.

2.1.3.1 Bending Moment

The design bending moment M [kNm], for the bulkhead corrugations is given by:

$$M = \frac{Fl}{8}$$

where:

F – resultant force, [kN], see sub-chapter 2.1.2.5,

l – span of the corrugation, [m], to be taken in accordance with Fig. 2.1.2.3.1-1 and Fig. 2.1.2.3.1-2.

2.1.3.2 Shear Force

The shear force Q , [kN], at the lower end of the bulkhead corrugations is given by:

$$Q = 0.8F$$

where:

F – see sub-chapter 2.1.2.5.

2.1.4 Strength Criteria

2.1.4.1 General

The following criteria are applicable to transverse bulkheads with vertical corrugations (see Fig. 2.1.2.3.1-1).

The requirements for local net plate thickness are specified in sub-chapter 2.1.4.7.

In addition, the criteria specified in 2.1.4.2 and 2.1.4.5 shall be fulfilled.

Where the corrugation angle ϕ shown in Fig. 2.1.2.3.1-1 is less than 50° , an horizontal row of staggered shedder plates shall be fitted at approximately mid depth of the corrugations (see Fig. 2.1.2.3.1-1) to help preserve dimensional stability of the bulkhead under flooding loads. The shedder plates shall be welded to the corrugations by double continuous welding, but they shall not be welded to the side shell.

The thicknesses of the lower part of corrugations considered in the application of sub-chapters 2.1.4.2 and 2.1.4.3 shall be maintained for a distance from the inner bottom (if no lower stool is fitted) or the top of the lower stool not less than $0.15l$.

The thicknesses of the middle part of corrugations considered in the application of sub-chapters 2.1.4.2 and 2.1.4.4 shall be maintained to a distance from the deck (if no upper stool is fitted) or the bottom of the upper stool not greater than $0.3l$.

2.1.4.2 Bending Capacity and Shear Stress

Bending capacity shall fulfil the following relationship:

$$10^3 \frac{M}{0.5Z_{le}\sigma_{a,le} + Z_m\sigma_{a,m}} \leq 1.0$$

where:

M – bending moment [kNm], see sub-chapter 2.1.3.1,

Z_{le} – section modulus of one half pitch corrugation [cm^3], at the lower end of corrugations, to be calculated in accordance with sub-chapter 2.1.4.3,

Z_m – section modulus of one half pitch corrugation [cm^3], at the mid-span of corrugations, to be calculated in accordance with sub-chapter 2.1.4.4,

$\sigma_{a,le}$ – allowable stress [MPa], as specified in sub-chapter 2.1.4.5, for the lower end of corrugations,

$\sigma_{a,m}$ – allowable stress [MPa], as specified in sub-chapter 2.1.4.5, for the mid-span of corrugations.

In no case Z_m shall be taken greater than the lesser of $1.15Z_{le}$ and $1.15Z'_{le}$ for calculation of the bending capacity, Z'_{le} being defined below.

In case effective shedder plates are fitted which:

- are not knuckled;
- are welded to the corrugations and the top of the lower stool by one side penetration welds or equivalent;
- are fitted with a minimum slope of 45° and their lower edge is in line with the stool side plating;

or effective gusset plates are fitted which:

- are fitted in line with the stool side plating;
- have material properties at least equal to those provided for the flanges,

the section modulus Z_{le} , [cm^3], shall be taken not larger than the value Z'_{le} , [cm^3], given by:

$$Z'_{le} = Z_g + 10^3 \frac{Qh_g - 0.5h_g^2 s_1 p_g}{\sigma_a}$$

where:

- Z_g – section modulus of one half pitch corrugation [cm^3] of the corrugations calculated in accordance with 2.1.4.4, in way of the upper end of shedder or gusset plates, as applicable,
- Q – shear force [kN], see sub-chapter 2.1.3.2,
- h_g – height, [m], of shedder or gusset plates, as applicable (see Fig. 2.1.4-1, Fig. 2.1.4-2, Fig. 2.1.4-3 and Fig. 2.1.4-4),
- s_1 – see paragraph 2.1.2.3.1 a),
- p_g – resultant pressure [kPa], as defined in sub-chapter 2.1.2.5, calculated in way of the middle of the shedder or gusset plates, as applicable,
- σ_a – allowable stress [MPa], see sub-chapter 2.1.4.5.

Stresses τ are obtained by dividing the shear force Q by the shear area. The shear area shall be reduced in order to account for possible non-perpendicularity between the corrugation webs and flanges. In general, the reduced shear area may be obtained by multiplying the web sectional area by $\sin\phi$ (ϕ being the angle between the web and the flange, shown in Fig. 2.1.2.3.1-1).

When calculating the section moduli and the shear area, the net plate thicknesses shall be used.

The section moduli of corrugations shall be calculated on the basis of the requirements specified in sub-chapters 2.1.4.3 and 2.1.4.4.

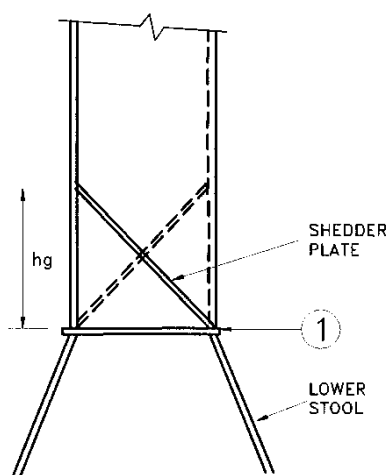

Fig. 2.1.4-1
Symmetric shedder plates

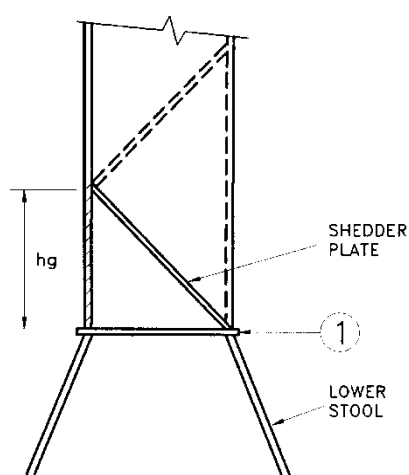

Fig. 2.1.4-2
Asymmetric shedder plates

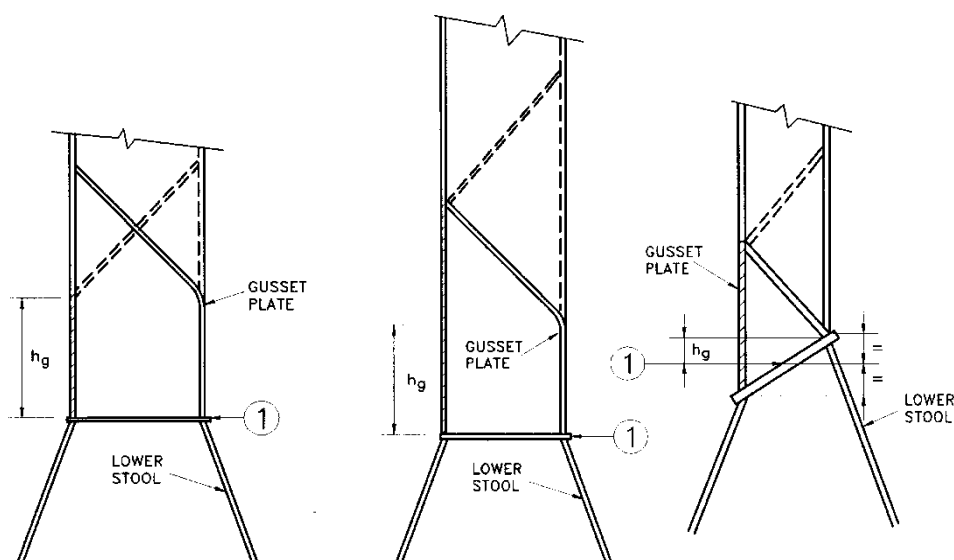

Fig. 2.1.4-3

Symmetric gusset/shedder plates

Fig. 2.1.4-4

Asymmetric gusset/shedder plates

2.1.4.3 Section Modulus at Lower End of Corrugations

The section modulus shall be calculated with the compression flange having an effective flange width, b_{ef} , not larger than specified in paragraph 2.1.4.6.1.

If the corrugation webs are not supported by local brackets below the stool top (or below the inner bottom) in the lower part, the section modulus of the corrugations shall be calculated considering the corrugation webs 30% effective.

a) Provided that effective shedder plates, as specified in paragraph 2.1.4.2, are fitted (see Fig. 2.1.4-1 and Fig. 2.1.4-2), when calculating the section modulus of corrugations at the lower end (cross-section ① in Fig. 2.1.4-1 and Fig. 2.1.4-2), the area of flange plates, [cm²], may be increased by:

$$\left(2.5a \sqrt{t_f t_{sh}} \sqrt{\frac{R_{esh}}{R_{eft}}} \right) \text{ not to be taken greater than } 2.5 a t_f \text{ where:}$$

a – width, [m], of the corrugation flange (see Fig. 2.1.2.3-1),

t_{sh} – net shedder plate thickness, [mm],

t_f – net flange thickness, [mm],

R_{esh} – minimum upper yield stress, [MPa], of the material used for the shedder plates,

R_{eft} – minimum upper yield stress, [MPa], of the material used for the corrugation flanges.

b) Provided that effective gusset plates, as defined in sub-chapter 2.1.4.2, are fitted (see Fig. 2.1.4-3 and Fig. 2.1.4-4), when calculating the section modulus of corrugations at the lower end (cross-section ① in Fig. 2.1.4-3 and Fig. 2.1.4-4), the area of flange plates, [cm²], may be increased by $(7 \cdot h_g \cdot t_{gu})$ where:

h_g – height of gusset plate, [m], see Fig. 2.1.4-3 and Fig. 2.1.4-4, not to be taken greater than

$$\left(\frac{10}{7} s_{gu} \right)$$

s_{gu} – width of the gusset plate, [m],

t_{gu} – net gusset plate thickness, [mm], not to be taken greater than t_f ,

t_f – net flange thickness, [mm].

c) If the corrugation webs are welded to a sloping stool top plate, which are at an angle not less than 45° with the horizontal plane, the section modulus of the corrugations may be calculated considering the corrugation webs fully effective. In case effective gusset plates are fitted, when calculating the section modulus of corrugations the area of flange plates may be increased as specified in b) above. No credit can be given to shedder plates only.

For angles less than 45°, the effectiveness of the web may be obtained by linear interpolation between 30% for 0° and 100% for 45°.

2.1.4.4 Section Modulus of Corrugations at Cross-Sections other than the Lower End

The section modulus shall be calculated with the corrugation webs considered effective and the compression flange having an effective flange width, b_{ef} , not larger than as specified in paragraph 2.1.4.6.1.

2.1.4.5 Allowable Stress Check

The normal and shear stresses σ and τ shall not exceed the allowable values σ_a and τ_a [MPa], given by:

$$\begin{aligned}\sigma_a &= R_e \\ \tau_a &= 0.5R_e\end{aligned}$$

R_e – minimum upper yield stress, [MPa], of the material.

2.1.4.6 Effective Compression Flange Width and Shear Buckling Check

2.1.4.6.1 Effective Width of the Compression Flange of Corrugations

The effective width b_{ef} [m], of the corrugation flange is given by:

$$b_{ef} = C_e a$$

where:

$$C_e = \frac{2.25}{\beta} - \frac{1.25}{\beta^2} \text{ for } \beta > 1.25;$$

$$C_e = 1.0 \text{ for } \beta \leq 1.25;$$

$$\beta = 10^3 \frac{a}{t_f} \sqrt{\frac{R_e}{E}};$$

t_f – net flange thickness, [mm],

a – width, [m], of the corrugation flange (see Fig. 2.1.2.3.1-1),

R_e – minimum upper yield stress, [MPa], of the material,

E – modulus of elasticity, [MPa], to be assumed equal to $2.06 \cdot 10^5$ MPa, for steel.

2.1.4.6.2 Shear

The buckling check shall be performed for the web plates at the corrugation ends.

The shear stress τ shall not exceed the critical value τ_c [MPa], obtained by the following:

$$\tau_c = \tau_E \text{ when } \tau_E \leq \frac{\tau_F}{2};$$

$$\tau_c = \tau_F \left(1 - \frac{\tau_F}{4\tau_E} \right) \text{ when } \tau_E > \frac{\tau_F}{2};$$

$$\tau_F = \frac{R_e}{\sqrt{3}}$$

where:

R_e = minimum upper yield stress, [MPa], of the material;

$$\tau_E = 0.9k_t E \left(\frac{t}{1000c} \right)^2 \text{ [MPa]}$$

k_t , E , t and c are given by:

$k_t = 6.34$,

E – modulus of elasticity of material as specified in paragraph 2.1.4.6.1,

t – net thickness [mm] of corrugation web,

c – width [m] of corrugation web (see Fig. 2.1.2.3.1-1).

2.1.4.7 Local Net Plate Thickness

The bulkhead local net plate thickness, t , [mm], is given by:

$$t = 14.9s_w \sqrt{\frac{p}{R_e}}$$

where:

s_w – plate width [m] to be taken equal to the width of the corrugation flange or web, whichever is the greater;

p – resultant pressure [kPa], as specified in sub-chapter 2.1.2.5, at the bottom of each strake of plating; in all cases, the net thickness of the lowest strake shall be determined using the resultant pressure at the top of the lower stool, or at the inner bottom if no lower stool is fitted or at the top of shedders; if shedder or gusset/shedder plates are fitted;

R – minimum upper yield stress [MPa] of the material.

For built-up corrugation bulkheads, when the thicknesses of the flange and web are different, the net thickness of the narrower plating shall be not less than t_n , [mm], given by:

$$t_n = 14.9s_n \sqrt{\frac{p}{R_e}} \text{ [mm]}$$

s_n – being the width, [m], of the narrower plating.

The net thickness of the wider plating [mm] shall not be taken less than the maximum of the following values:

$$t_w = 14.9s_w \sqrt{\frac{p}{R_e}}$$

$$t_w = \sqrt{\frac{440s_w^2 p}{R_e} - t_{np}^2}$$

where $t_{np} \leq$ actual net thickness of the narrower plating and not to be greater than:

$$t = 14.9s_w \sqrt{\frac{P}{R_e}}$$

2.1.5 Local Details

As applicable, the design of local details shall fulfil the requirements specified in this Part of the *Rules* for the purpose of transferring the corrugated bulkhead forces and moments to the boundary structures, in particular to the double bottom and cross-deck structures.

The thickness and stiffening of gusset and shedder plates, installed for strengthening purposes, shall fulfil the requirements specified in sub-chapter 9.4 for the allowable stresses determined in accordance with paragraph 13.4.2.3 or 13.5.2.1 of the *Rules* and for the design loads specified in sub-chapter 2.1.2 of the *Supplement*.

Unless otherwise stated, weld connections and materials shall be dimensioned and selected in accordance with the requirements specified in this Part of the *Rules* (Chapters 2 and 4).

2.1.6 Corrosion Addition and Steel Renewal

Renewal/reinforcement shall be done in accordance with the following requirements and the guidelines contained in the Annex 1.

- a) Steel renewal is required where the gauged thickness is less than $t_{net} + 0.5$ mm, t_{net} being the thickness used for the calculation of bending capacity and shear stresses as specified in sub-chapter 2.1.4.2 or the local net plate thickness as specified in sub-chapter 2.1.4.7. Alternatively, reinforcing doubling strips may be used, providing the net thickness is not dictated by shear strength requirements for web plates (see sub-chapter 2.1.4.5 and paragraph 2.1.4.6.2) or by local pressure requirements for web and flange plates (see sub-chapter 2.1.4.7).

Where the gauged thickness is within the range $t_{net} + 0.5$ mm and $t_{net} + 1.0$ mm, coating (applied in accordance with the coating manufacturer's requirements) or annual gauging may be adopted as an alternative to steel renewal.

- b) Where steel renewal or reinforcement is required, a minimum thickness of $t_{net} + 2.5$ mm shall be replenished for the renewed or reinforced parts.
- c) When:

$$0.8(R_{efl} t_{fl}) \geq R_{es} t_{st}$$

where:

- R_{efl} – minimum upper yield stress [MPa] of the material used for the corrugation flanges,
 R_{es} – minimum upper yield stress [MPa] of the material used for the lower stool side plating or floors (if no stool is fitted),
 t_{fl} – flange thickness [mm], which is found to be acceptable on the basis of the criteria specified in a) above or, when steel renewal is required, the replenished thickness in accordance with the criteria specified in b) above.

The above flange thickness dictated by local pressure requirements (see sub-chapter 2.1.4.7) need not be considered for this purpose,

- t_{st} – as built thickness [mm] of the lower stool side plating or floors (if no stool is fitted) gussets with shedder plates, (Fig. 2.1.4-3, 2.1.4-4) extending from the lower end of corrugations up to $0.1l$ or reinforcing doubling strips (on bulkhead corrugations and stool side plating) shall be fitted.

If gusset plates are fitted, the material of such gusset plates shall be the same as that of the corrugation flanges. The gusset plates shall be connected to the lower stool shelf plate or inner bottom (if no lower stool is fitted) by deep penetration welds (see Fig. 2.1.6).

- d) Where steel renewal is required, the bulkhead connections to the lower stool shelf plate or inner bottom (if no stool is fitted) shall be at least made by deep penetration welds (see Fig. 2.1.6).
- e) Where gusset plates are to be fitted or renewed, their connections with the corrugations and the lower stool shelf plate or inner bottom (if no stool is fitted) shall be at least made by deep penetration welds (see Fig. 2.1.6).

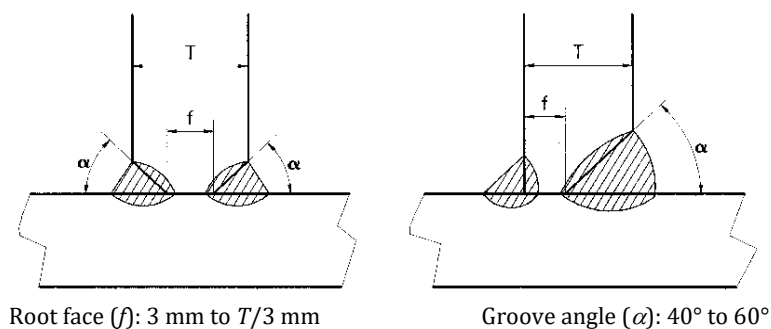

Fig. 2.1.6

2.2 Evaluation of Allowable Hold Loading of Cargo Hold No. 1 with Cargo Hold No. 1 Flooded, for Existing Bulk Carriers

2.2.1 Application and Definitions

The requirements specified in this sub-chapter apply to all bulk carriers of length $L_0 \geq 150$ m in the foremost hold, intended to carry solid bulk cargoes having a density of 1.78 t/m^3 , or above, with single deck, topside tanks and hopper tanks, where:

- .1 the foremost hold is bounded by the side shell only for ships which were contracted for construction prior to 1 July 1998, and have not been constructed in accordance with the requirements specified in sub-chapter 20.8;
- .2 the foremost hold is double side skin construction of less than 760 mm breadth measured perpendicular to the side shell in ships, the keels of which were laid, or which were at a similar stage of construction, before 1 July 1999 and have not been constructed in accordance with the requirements specified in sub-chapter 20.8.

Early completion of a special survey coming due after 1 July 1998 to postpone compliance is not allowed.

The loading in cargo hold No. 1 shall not exceed the allowable hold loading in the flooded condition, calculated as per sub-chapter 2.2.4, using the loads given in sub-chapter 2.2.2 and the shear capacity of the double bottom given in sub-chapter 2.2.3.

In no case the allowable hold loading in flooding condition shall be taken greater than the design hold loading in intact condition.

2.2.2 Load Model

2.2.2.1 General

The loads to be considered as acting on the double bottom of hold No. 1 are those given by the external sea pressures and the combination of the cargo loads with those induced by the flooding of hold No. 1.

The most severe combinations of cargo induced loads and flooding loads shall be used, depending on the loading conditions included in the loading manual:

- homogeneous loading conditions;
- non homogeneous loading conditions;
- packed cargo conditions (such as steel mill products).

For each loading condition, the maximum bulk cargo density to be carried shall be considered in calculating the allowable hold limit.

2.2.2.2 Inner Bottom Flooding Head

The flooding head h_f (see Fig. 2.2.2.2) is the distance, [m], measured vertically with the ship in the upright position, from the inner bottom to a level located at a distance d_f [m], from the base plane equal to:

- D in general,
- $0.95D$ for ships less than 50,000 tonnes deadweight with Type B freeboard,

D being the distance, [m], from the base plane to the freeboard deck at side amidship (see Fig. 2.2.2.2).

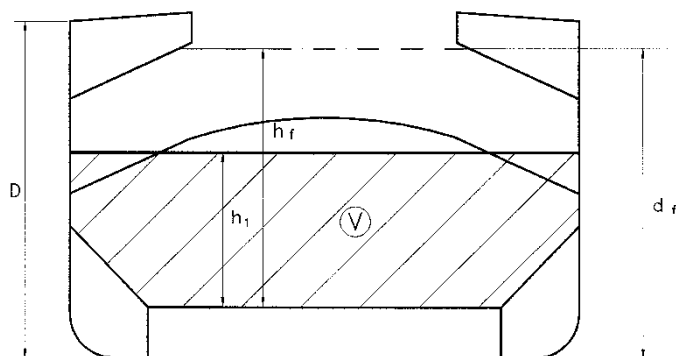

V = Volume of cargo

Fig. 2.2.2.2

2.2.3 Shear Capacity of the Double Bottom of Hold No. 1

The shear capacity of the double bottom of hold No. 1 is defined as the sum of the shear strength at each end of:

- all floors adjacent to both hoppers, less one half of the strength of the two floors adjacent to each stool, or transverse bulkhead if no stool is fitted (see Fig. 2.2.3-1),
- all double bottom girders adjacent to both stools, or transverse bulkheads if no stool is fitted.

The strength of girders or floors which run out and are not directly attached to the boundary stool or hopper girder shall be evaluated for the one end only.

Note that the floors and girders to be considered are those inside the hold boundaries formed by the hoppers and stools (or transverse bulkheads if no stool is fitted). The hopper side girders and the floors directly below the connection of the bulkhead stools (or transverse bulkheads if no stool is fitted) to the inner bottom shall not be included.

When the geometry and/or the structural arrangement of the double bottom are such to make the above assumptions inadequate, the shear capacity of the double bottom is subject to special consideration by PRS.

In calculating the shear strength, the net thicknesses of floors and girders shall be used. The net thickness t_{net} [mm], shall be determined in accordance with the following formula:

$$t_{net} = t - t_c$$

where:

t – as built thickness [mm] of floors and girders,

t_c – corrosion diminution, equal to 2 mm, in general; a lower value of t_c may be adopted, provided that measures are taken, to the PRS satisfaction, to justify the assumption made.

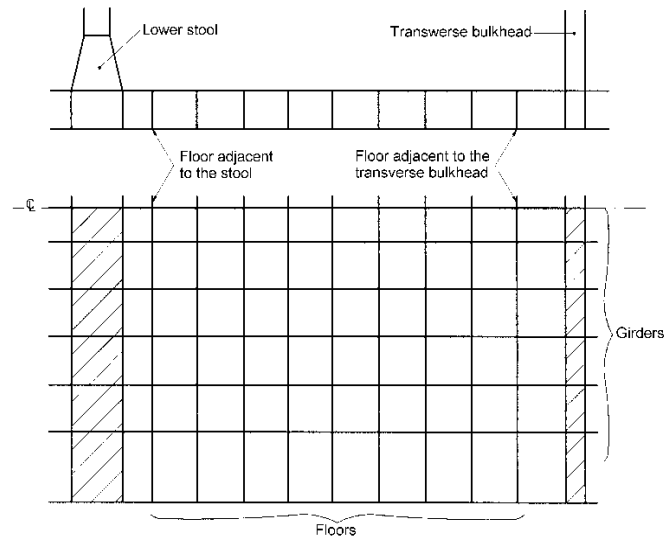

Fig. 2.2.3-1

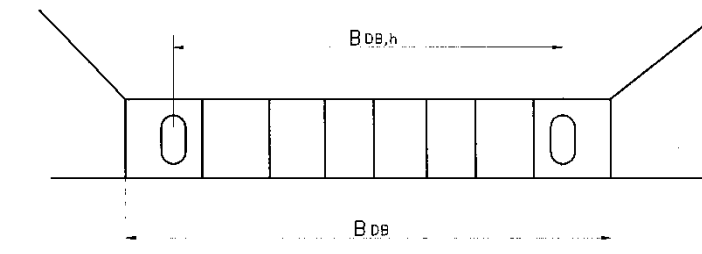

Fig. 2.2.3-2

2.2.3.1 Floor Shear Strength

The floor shear strength in way of the floor panel adjacent to hoppers S_{f1} [kN], and the floor shear strength in way of the openings in the “outermost” bay (i.e. that bay which is closest to hopper) S_{f2} [kN], are given by the following expressions:

$$S_{f1} = 10^{-3} A_f \frac{\tau_a}{\eta_1};$$

$$S_{f2} = 10^{-3} A_{f,h} \frac{\tau_a}{\eta_2}$$

where:

A_f – sectional area [mm²] of the floor panel adjacent to hoppers,

$A_{f,h}$ – net sectional area [mm²] of the floor panels in way of the openings in the “outermost” bay (i.e. that bay which is closest to hopper),

τ_a – allowable shear stress [MPa] to be taken equal to:

$$\frac{R_e}{\sqrt{3}}$$

R_e – minimum upper yield stress [MPa] of the material;

$\eta_1 = 1.10$;

$\eta_2 = 1.20$;

η_2 may be reduced, upon PRS' agreement, down to 1.10 where appropriate reinforcements are fitted.

2.2.3.2 Girder Shear Strength

The girder shear strength in way of the girder panel adjacent to stools (or transverse bulkheads, if no stool is fitted) S_{g1} [kN], and the girder shear strength in way of the largest opening in the “outermost” bay (i.e. that bay which is closest to stool, or transverse bulkhead, if no stool is fitted) S_{g2} [kN], are given by the following expressions:

$$S_{g1} = 10^{-3} A_g \frac{\tau_a}{\eta_1};$$

$$S_{g2} = 10^{-3} A_{g,h} \frac{\tau_a}{\eta_2}$$

where:

A_g – minimum sectional area [mm²] of the girder panel adjacent to stools (or transverse bulkheads, if no stool is fitted);

$A_{g,h}$ – net sectional area [mm²] of the girder panel in way of the largest opening in the “outermost” bay (i.e. that bay which is closest to stool, or transverse bulkhead, if no stool is fitted);

τ_a – allowable shear stress [MPa] as given in sub-chapter 2.2.3.1;

$\eta_1 = 1.10$;

$\eta_2 = 1.15$;

η_2 may be reduced, upon PRS' agreement, down to 1.10 where appropriate reinforcements are fitted.

2.2.4 Allowable Hold Loading

Allowable hold loading W [t], is given by:

$$W = \rho_c V \frac{1}{F}$$

where:

$F = 1.05$ in general,

1.00 for steel mill products,

ρ_c – cargo density [t/m³]; for bulk cargoes see sub-chapter 2.2.2.1; for steel products, ρ_c shall be taken as the density of steel,

V – volume [m³] occupied by cargo at a level h_1 (see Fig. 2.2.2.2),

$$h_1 = \frac{X}{\rho_c g}$$

X – for bulk cargoes, the lesser of X_1 and X_2 given by:

$$X_1 = \frac{Z + \rho g(E - h_f)}{1 + \frac{\rho}{\rho_c}(\text{perm} - 1)}$$

$$X_2 = Z + \rho g(E - h_f \text{perm})$$

X – for steel products, X may be taken as X_1 , using $\text{perm} = 0$;

ρ – sea water density [t/m^3];

$g = 9,81 \text{ m}/\text{s}^2$, gravity acceleration;

$E = d_f - 0,1D$;

d_f, D – see sub-chapter 2.2.2.2;

h_f – flooding head, [m], see sub-chapter 2.2.2.2;

perm – permeability of cargo, to be taken as 0.3 for ore (corresponding bulk cargo density for iron ore may generally be taken as $3.0 \text{ t}/\text{m}^3$);

Z – the lesser of Z_1 and Z_2 given by:

$$Z_1 = \frac{C_h}{A_{DB,h}};$$

$$Z_2 = \frac{C_e}{A_{DB,e}}$$

C_h – shear capacity of the double bottom, [kN], as specified in sub-chapter 2.2.3, considering, for each floor, the lesser of the shear strengths S_{f1} and S_{f2} (see sub-chapter 2.2.3.1) and, for each girder, the lesser of the shear strengths S_{g1} and S_{g2} (see sub-chapter 2.2.3.2);

C_e – shear capacity of the double bottom, [kN], as specified in sub-chapter 2.2.3, considering, for each floor, the shear strength S_{f1} (see sub-chapter 2.2.3.1) and, for each girder, the lesser of the shear strengths S_{g1} and S_{g2} (see sub-chapter 2.2.3.2);

$$A_{DB,h} = \sum_{i=1}^{i=n} S_i B_{DB,i};$$

$$A_{DB,e} = \sum_{i=1}^{i=n} S_i (B_{DB} - s)$$

n – number of floors between stools (or transverse bulkheads, if no stool is fitted),

S_i – space of i th-floor [m];

$B_{DB,i} = B_{DB} - s_i$ for floors whose shear strength is given by S_{f1} (see sub-chapter 2.2.3.1);

$B_{DB,i} = B_{DB,h}$ for floors whose shear strength is given by S_{f2} (see sub-chapter 2.2.3.1);

B_{DB} – breadth of double bottom [m] between hoppers (see Fig. 2.2.3-2);

$B_{DB,h}$ – distance [m] between the two considered openings (see Fig. 2.2.3-2);

s – spacing [m] of double bottom longitudinals adjacent to hoppers.

2.3 Corrosion protection coatings for cargo hold spaces on bulk carriers

For existing bulk carriers, where owners decide to coat or recoat cargo hold surfaces, i.e. all internal and external surfaces of hatch coamings and hatch covers, and all internal surfaces of the cargo holds, excluding the flat tank top areas and the hopper tanks sloping plating approximately

300 mm below the side shell frame and brackets, the extent of the close-up and thickness measurement surveys is subject to special consideration by PRS.

2.4 Ship loading control

2.4.1 Bulk carriers, ore carriers and combination carriers of $L_0 \geq 150$ m, which are contracted for construction before 1st July 1998 shall be provided with an approved loading instrument of a type to the satisfaction of PRS, not later than their entry into service or 1st January 1999, whichever occurs later.

2.4.2 In addition, single side skin bulk carriers of $L_0 \geq 150$ m, which are contracted for construction before 1st July 1998 shall be provided, before 1st July 1999 or their entry into service, whichever occurs later, with approved loading manual with typical loading sequences where the vessel is loaded from commencement of cargo loading to reaching full deadweight capacity, for homogeneous conditions, relevant partial loading conditions and alternate loading conditions where applicable. Typical unloading sequences for these conditions are also to be included.

2.4.3 Conditions to be fulfilled by the loading instrument and loading manual are specified in *Publication 16/P – Loading Guidance Information*.

2.5 Restrictions on Sailing with any Hold Empty

Bulk carriers of 150 m in length and upwards of single-side skin construction, constructed before 1 July 1999, carrying cargoes having a density of 1.78 t/m³ and above, if not meeting the requirements specified in sub-chapters 20.5, 20.6, 20.7 or 20.8 shall not sail with any hold loaded less than 10% of the hold's maximum allowable cargo weight when in the full load condition, after reaching 10 years of age.

The applicable full load condition for this requirement is a load equal to or greater than 90% of the ship's deadweight at the relevant assigned freeboard.

2.6 Retroactive Requirements for Sides of Bulk Carriers and Oil-Bulk-Ore Carriers

Bulk carriers and oil-bulk-ore carriers with single-side skin construction shall fulfil the requirements specified in *Publication 63/P – Renewal Criteria for Side Shell Frames and Brackets in Single Side Skin Bulk Carriers and Oil-Bulk-Ore Carriers*, in accordance with the schedule given in the above-mentioned document.

ANNEX 1
GUIDELINES ON RENEWAL/REINFORCEMENT
OF VERTICALLY CORRUGATED TRANSVERSE WATERTIGHT BULKHEAD
BETWEEN CARGO HOLDS NO. 1 AND NO. 2

1. The need for renewal or reinforcement of the vertically corrugated transverse watertight bulkhead between cargo holds Nos. 1 and 2 will be determined by PRS on a case by case basis using the criteria specified in sub-chapter 2.1 in association with the most recent gaugings and findings from survey.
2. In addition to class requirements, the 2.1 assessment of the transverse corrugated bulkhead shall take into account the following:
 - a) Scantlings of individual vertical corrugations shall be assessed for reinforcement/renewal based on thickness measurements obtained in accordance with Annex 2 at their lower end, at mid-depth and in way of plate thickness changes in the lower 70%. These considerations will take into account the provision of gussets and shedder plates and the benefits they offer, provided that they fulfil the requirements specified in sub-chapters 2.1.4.2 and 2.1.6.
 - b) Taking into account the scantlings and arrangements for each case, permissible levels of diminution shall be determined and appropriate measures taken in accordance with sub-chapter 2.1.6.
3. Where renewal is required, the extent of renewal shall be shown clearly in plans. The vertical distance of each renewal zone shall be determined by considering the requirements specified in sub-chapter 2.1 and in general shall be not less than 15% of the vertical distance between the upper and lower end of the corrugation – measured at the ship's centre plane.
4. Where the reinforcement is accepted by adding strips, the length of the reinforcing strips shall be sufficient to allow it to extend over the whole depth of the diminished plating. In general, the width and thickness of strips should be sufficient to fulfil the requirements specified in sub-chapter 2.1. The material of the strips shall be the same as that of the corrugation plating. The strips shall be attached to the existing bulkhead plating by continuous fillet welds. The strips shall be suitably tapered or connected at ends in the way accepted by PRS.
5. Where reinforcing strips are connected to the inner bottom or lower stool shelf plates, one side full penetration welding shall be used. When reinforcing strips are fitted to the corrugation flange and are connected to the lower stool shelf plate, they are normally to be aligned with strips of the same scantlings welded to the stool side plating and having a minimum length equal to the breadth of the corrugation flange.
6. Fig. 1 gives a general arrangement of structural reinforcement.

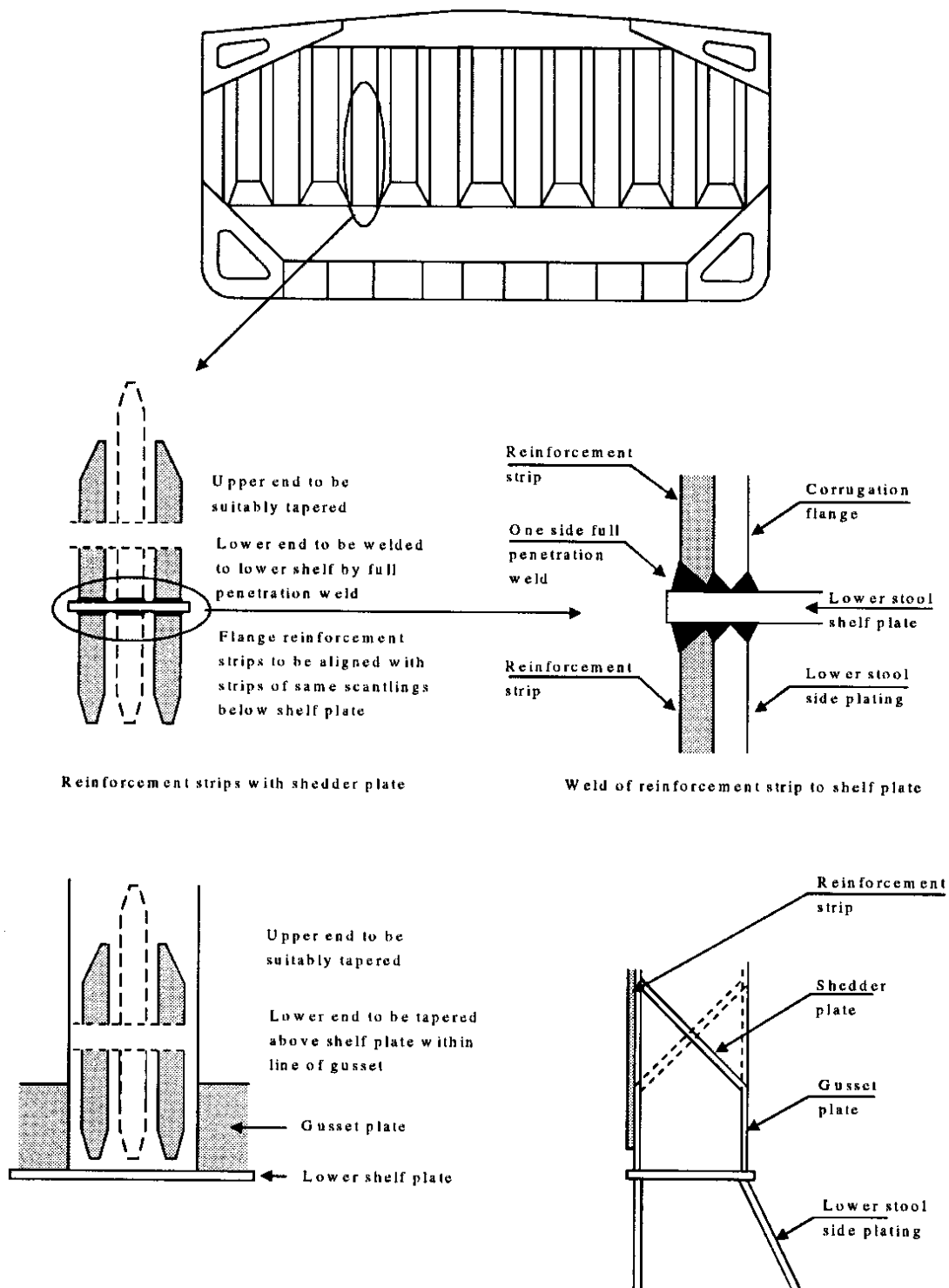

Reinforcement strips with shedder and gusset plates

Fig. 1

Notes to Fig. 1 on reinforcement:

1. Square or trapezoidal corrugations shall be reinforced with plate strips fitted to each corrugation flange sufficient to fulfil the requirements specified in sub-chapter 2.1.
2. The number of strips fitted to each corrugation flange shall be sufficient to fulfil the requirements specified in sub-chapter 2.1.

3. The shedder plate may be fitted in one piece or prefabricated with a welded knuckle (gusset plate).
4. Gusset plates, where fitted, shall be welded to the shelf plate in line with the flange of the corrugation, to reduce the stress concentrations at the corrugation corners. Ensure good alignment between gusset plate, corrugation flange and lower stool sloping plate. Use deep penetration welding at all connections. Ensure start and stop of welding is as far away as practically possible from corners of corrugation.
5. Shedder plates shall be attached by one side full penetration welds onto backing bars.
6. Shedder and gusset plates shall have a thickness equal to or greater than the original bulkhead thickness. Gusset plate shall have a minimum height (on the vertical part) equal to the half of the width of the corrugation flange. Sheddens and gussets shall be of the same material as flange material.

ANNEX 2
GUIDELINES FOR GAUGING OF VERTICALLY CORRUGATED TRANSVERSE WATERTIGHT BULKHEAD BETWEEN HOLDS NO. 1 AND NO. 2

1. Gauging is necessary to determine the general condition of the structure and to define the extent of possible repairs and/or reinforcements of the vertically corrugated transverse watertight bulkhead for verification of the compliance with 2.1 of the *Supplement*.
2. Taking into account the buckling model applied in sub-chapter 2.1 in the evaluation of strength of the bulkhead, it is essential to determine the thickness diminution at the critical levels shown in Fig. 1 and Fig. 2.
3. The gauging shall be carried out at the three levels as described below. To adequately assess the scantlings of each individual vertical corrugation, each corrugation flange web, shedder plate and gusset plate within each of the levels given below shall be gauged.

Level (a) – ships without lower stool (see Fig. 1):

Locations:

- the mid-breadth of the corrugation flanges at approximately 200 mm above the line of shedder plates;
- the middle of gusset plates between corrugation flanges, where fitted;
- the middle of the shedder plates;
- the mid-breadth of the corrugation webs at approximately 200 mm above the line of shedder plates.

Level (b) – ships with lower stool (see Fig. 2):

Locations:

- the mid-breadth of the corrugation flanges at approximately 200 mm above the line of shedder plates;
- the middle of gusset plates between corrugation flanges, where fitted;
- the middle of the shedder plates;
- the mid-breadth of the corrugation webs at approximately 200 mm above the line of shedder plates.

Level (c) – ships with or without lower stool (see Fig. 1 and 2):

Locations:

- the mid-breadth of the corrugation flanges and webs at about the mid-height of the corrugation.
4. Where the thickness changes within the horizontal levels, the thinner plate shall be gauged.
 5. Steel renewal and/or reinforcement shall fulfil the requirements specified in sub-chapter 2.1.

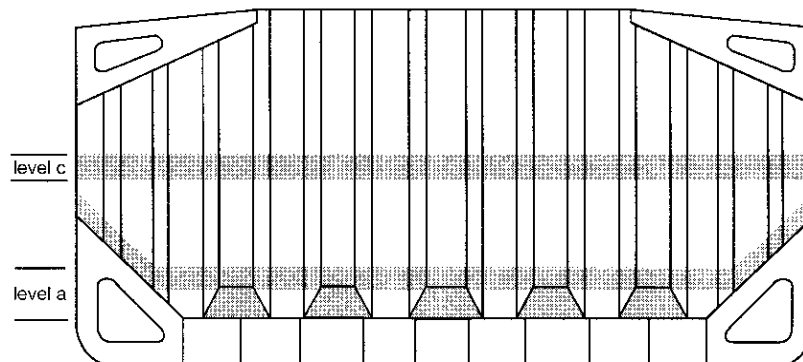

Fig. 1

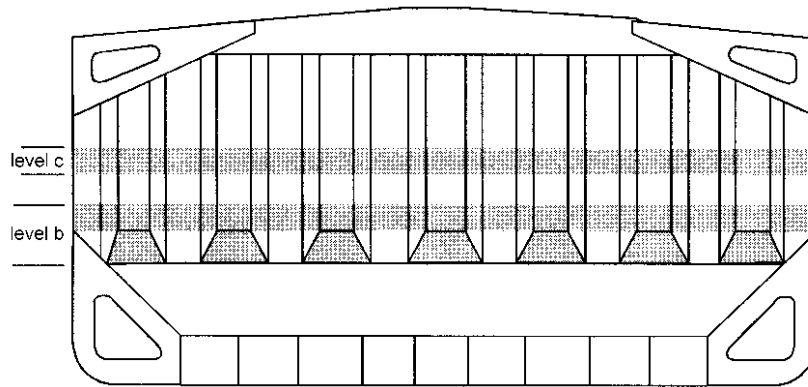
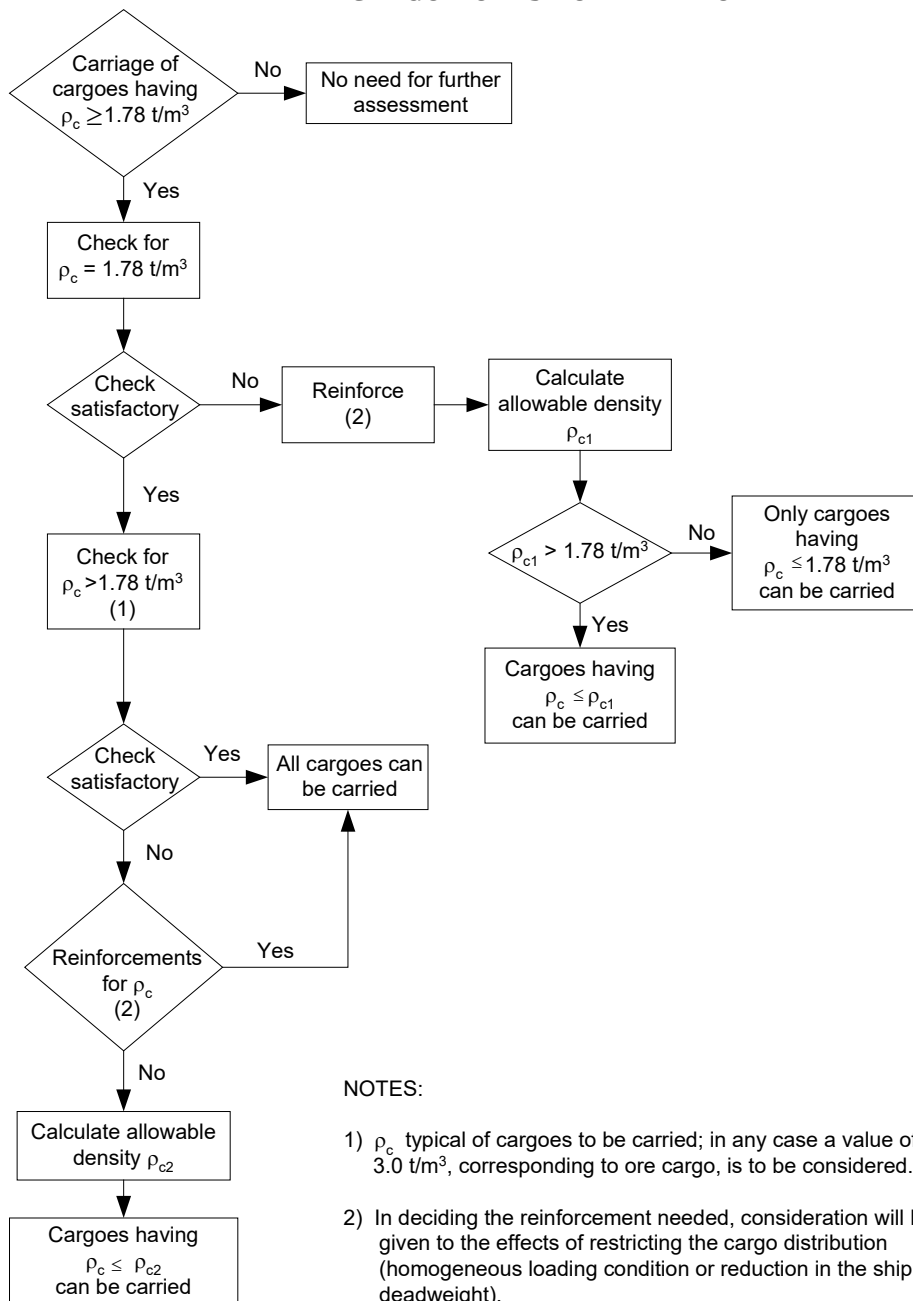

Fig. 2

ANNEX 3
GUIDELINES FOR ASSESSMENT OF CAPABILITY OF CARRIAGE OF HIGH DENSITY CARGOES
ON EXISTING BULK CARRIERS ACCORDING TO STRENGTH OF TRANSVERSE BULKHEAD
BETWEEN CARGO HOLDS NO. 1 AND NO. 2



NOTES:

- 1) ρ_c typical of cargoes to be carried; in any case a value of 3.0 t/m³, corresponding to ore cargo, is to be considered.
- 2) In deciding the reinforcement needed, consideration will be given to the effects of restricting the cargo distribution (homogeneous loading condition or reduction in the ship deadweight).

List of amendments effective on the 1 April 2024

<i>Item</i>	<i>Title/Subject</i>	<i>Source</i>
All chapters	In the whole text of Part II (except the Supplement), requirements for existing ships have been removed, leaving requirements for newly built ships.	PRS
6.1.2	Requirements for double bottom have been updated	SOLAS II-1/9; MSC.429(98)/Rev.2
9	Requirements for watertight bulkheads have been updated	SOLAS II-1/10; MSC.429(98)/Rev.2

List of amendments effective on the 1 July 2024

<i>Item</i>	<i>Title/Subject</i>	<i>Source</i>
11.3	Sternframe	IACS UR S10 (Rev.7 Feb 2023) and (Corr.1 June 2023)
15.14	Buckling strength of hull structure subject to hull girder stresses	IACS UR S35
10.3.1.2	Thickness of plating	IACS UR S3 Rev.2 June 2023