



RULES

PUBLICATION 95/P

SURVEY REQUIREMENTS FOR SHELL AND INNER DOORS OF RO-RO SHIPS

January
2012

Publications P (Additional Rule Requirements) issued by Polski Rejestr Statków complete or extend the Rules and are mandatory where applicable.

GDAŃSK

A decorative graphic at the bottom of the page consists of several overlapping, wavy blue lines that create a sense of movement and depth, extending across the width of the page.

Publication No. 95/P – Survey Requirements for Shell and Inner Doors of ro-ro Ships – January 2012, based on the IACS Unified Requirements Z24, Nov 2010, is an extension of the requirements contained in Part I – Classification Regulations of the Rules for the Classification and Construction of Sea-going Ships.

This Publication was approved by the PRS Board on 1 December 2011 and enters into force on 1 January 2012.

© Copyright by Polish Register of Shipping*, 2011

* *Polish Register of Shipping means Polski Rejestr Statków S.A., seated in Gdańsk, al. gen. Józefa Hallera 126, 80-416 Gdańsk, Poland, registered in the Register of Entrepreneurs of the National Court Register, under entry number 0000019880. Polish Register of Shipping, its affiliates and subsidiaries, their respective officers, employees or agents are, individually and collectively, referred to as Polish Register of Shipping or as PRS for short.*

CONTENTS

	Page
1 General	5
1.1 Application	5
1.2 Definitions	5
2 Annual Survey	5
3 Class Renewal Survey	7
Enclosures	
Table I - Minimum Requirements for Close-up Surveys of Doors, Locking, Securing and Supporting Devices and Fittings	9

1 GENERAL

1.1 Application

1.1.1 The requirements of *Publication No 95/P – Survey Requirements for Shell and Inner Doors of Ro-ro Ships, 2012* apply to the survey of bow, inner, side shell and stern doors of ro-ro passenger and ro-ro cargo ships, to the extent appropriate to the arrangements and equipment of each ship.

1.1.2 The requirements are additional to the classification requirements applicable to the remainder of the ship.

1.1.3 Special consideration may be given in application of relevant sections of this *Publication* to commercial ships owned or chartered by Governments, which are utilized in support of military operations or service.

1.2 Definitions

1.2.1 Ro-ro ship – for the purpose of this *Publication* – is a ship which utilizes a loading ramp to enable wheeled vehicles to be rolled-on and rolled-off the ship.

1.2.2 Ro-ro passenger ship – a passenger ship with ro-ro spaces or special category spaces.

1.2.3 Ro-ro spaces – spaces not normally sub-divided in any way and normally extending to either a substantial length or the entire length of the ship, in which motor vehicles with fuel in their tanks for their own propulsion and/or goods (packaged or in bulk, in or on rail or road cars, vehicles (including road or rail tankers), trailers, containers, pallets, demountable tanks or in or on similar stowage units or, other receptacles) can be loaded and unloaded normally in a horizontal direction.

1.2.4 Special category spaces – those enclosed vehicle spaces above or below the bulkhead deck, into and from which vehicles can be driven and to which passengers have access. Special category spaces may be accommodated on more than one deck provided that the total overall clear height for vehicles does not exceed 10 m.

1.2.5 Securing device – a device used to keep the door closed by preventing it from rotating about its hinges.

1.2.6 Supporting device – a device used to transmit external or internal loads from the door to a securing device and from the securing device to the ship's structure, or a device other than a securing device, such as a hinge, stopper or other fixed device, that transmits loads from the door to the ship's structure.

1.2.7 Locking device – a device that locks a securing device in the closed position.

1.2.8 Close-Up Survey – a survey where the details of structural components are within the close visual inspection range of the surveyor, i.e. normally within reach of hand.

2 ANNUAL SURVEY

2.1 The survey is to consist of an examination to verify, as far as is practicable, that the bow, inner, side shell and stern doors are maintained in a satisfactory condition.

2.2 Confirmation is to be obtained that no unapproved changes have been made to the bow, inner, side shell and stern doors since the last survey.

2.3 Documents

If an *Operating and Maintenance Manual* (OMM) is required, it is to be verified that an approved copy is on board and any possible modifications are included.

It is to be verified that documented operating procedures for closing and securing doors are kept on board and posted at an appropriate place. The surveyor shall examine the *Operating and Maintenance Manual* (OMM) with special attention to the register of inspections and its contents as a basis for the survey.

2.4 Structural examination

Bow, inner, side shell and stern doors are to be examined with particular attention paid to:

- Structural arrangement of doors including plating, secondary stiffeners, primary structure, hinging arms and welding;
- Shell structure surrounding the opening of the doors and the securing, supporting and locking devices including shell plating, secondary stiffeners, primary structure, and welding;
- Hinges and bearings, thrust bearings;
- Hull and door side supports for securing, supporting and locking devices;
- Close-up survey of securing, supporting and locking devices including welding, refer to Table 1.

Whenever a crack is found, an examination with NDT is to be carried out in the surrounding area and for similar items as considered necessary by the surveyor.

2.5 Measurement of clearances

Clearances of hinges, bearings and thrust bearings are to be taken, where no dismantling is required. Where the function test is not satisfactory, dismantling may be required to measure the clearances. If dismantling is carried out, a visual examination of hinge pins and bearings together with NDT of the hinge pin is to be carried out. Clearances of securing, supporting and locking devices are to be measured, where indicated in the *Operating and Maintenance Manual* (OMM).

2.6 Sealing arrangement

An examination of packing material / rubber gaskets and retaining bars or channels, including welding is to be carried out.

2.7 Drainage arrangement

An examination of drainage arrangement, including bilge wells and drain pipes is to be carried out, where fitted. A test of the bilge system between the inner and outer doors is to be carried out.

2.8 Function test of doors

Checking of the satisfactory operation of the bow, inner, side shell and stern doors during a complete opening and closing operation is to be made, as applicable, including:

- proper working of the hinging arms and hinges;
- proper engagement of the thrust bearings;
- device for locking the door in the open position;
- securing, supporting and locking devices;
- proper sequence of the interlock system for the opening / closing system and the securing and locking devices;
- mechanical lock of the securing devices;
- proper locking of hydraulic securing devices in the event of a loss of the hydraulic fluid, according to the procedure provided by the *Operating and Maintenance Manual* (OMM);

- correct indication of open / closed position of doors and securing / locking devices at navigation bridge and other control stations;
- isolation of the hydraulic securing / locking devices from other hydraulic systems;
- confirmation that the operating panels are inaccessible to unauthorized persons;
- verification that a notice plate giving instructions to the effect that all securing devices are to be closed and locked before leaving harbour is placed at each operating panel and supplemented by warning indicator lights;
- examination of electrical equipment for opening, closing and securing the doors.

2.9 Function test of the indicator system

Checking of the satisfactory operation of the indicator system, where fitted, is to be carried out, as applicable, including:

- proper visible indication and audible alarm on the navigation bridge panel, according to the selected function "harbour / sea voyage" and on the operating panel;
- lamp test function on both panels;
- verification that it is not possible to turn off the indicator light on both panels;
- verification of fail safe performance, according to the procedure provided by the *Operating and Maintenance Manual* (OMM);
- confirmation that power supply for indicator system is supplied by the emergency source or other secure power supply and independent of the power supply for operating the doors;
- proper condition of sensors and protection from water, ice formation and mechanical damage.

2.10 Test of water leakage detection system

Where fitted, the water leakage detection system is to be tested including proper audible alarm on the navigation bridge panel and on the engine control room panel, according to the procedure provided by the *Operating and Maintenance Manual* (OMM).

2.11 Test of television surveillance system

Where fitted, the television surveillance system is to be tested including proper indication on the navigation bridge monitor and on the engine control room monitor.

2.12 Tightness test

A hose test or equivalent is to be carried out. If the visual examination and function test have shown satisfactory results, the tightness test of shell doors on ro-ro cargo ships need not be carried out unless considered necessary by the attending surveyor.

2.13 NDT and Thickness Measurements

When considered necessary by the surveyor, NDT and thickness measurements may be required after visual examination and function test.

3 CLASS RENEWAL SURVEY

3.1 The Class Renewal Survey is to include, in addition to the requirements of the Annual Survey as required in paragraph 2, examination, tests and checks of sufficient extent to verify that the bow, inner, side shell and stern doors, are in satisfactory condition and considered able to remain in compliance with applicable requirements, subject to proper maintenance and operation in accordance with the *Operation and Maintenance Manual* (OMM) or manufacturer's recommendations and the periodical surveys being carried out at the due dates for the five year period until the next Class Renewal Survey.

3.2 The examinations of the doors are to be supplemented by thickness measurements and testing to verify compliance with applicable requirements so that the structural and weathertight integrity remain effective. The aim of the examination is to identify corrosion, significant deformation, fractures, damages or other structural deterioration, that may be present.

3.3 The bow, inner, side shell and stern doors are to be surveyed as follows:

3.3.1 A survey of the items listed in 2.4, including close-up survey of securing, supporting and locking devices, together with welding, is to be carried out, refer to Table 1.

3.3.2 Non-destructive testing and thickness measurements are to be carried out on securing, supporting and locking devices, including welding, to the extent considered necessary by PRS Surveyor. Whenever a crack is found, an examination with NDT is to be carried out in the surrounding area and for similar items as considered necessary by the surveyor.

3.3.3 The maximum thickness diminution of hinging arms, securing, supporting and locking devices is to be treated according to the PRS' requirements for primary structures, but is not to be more than 15% of the as-built thickness or the maximum corrosion allowance, whichever is less. Certain designs may be subject to special consideration.

3.3.4 Checking the effectiveness of sealing arrangements by hose testing or equivalent is to be carried out.

3.3.5 Clearances of hinges, bearings and thrust bearings are to be taken. Unless otherwise specified in the *Operating and Maintenance Manual* (OMM) or by manufacturer's recommendation, the measurement of clearances on ro-ro cargo ships may be limited to representative bearings where dismantling is needed in order to measure the clearances. If dismantling is carried out, a visual examination of hinge pins and bearings together with NDT of the hinge pin is to be carried out.

3.3.6 The non-return valves of the drainage system are to be dismantled and examined.

ENCLOSURES

Table I

MINIMUM REQUIREMENTS FOR CLOSE-UP SURVEYS OF DOORS, LOCKING, SECURING AND SUPPORTING DEVICES AND FITTINGS

The following is a list of the devices and fittings and associated welding to be subject to close-up survey by the attending PRS Surveyor:

- cylinder securing pins, supporting brackets, back-up brackets (where fitted) and their welded connections;
- hinge pins, supporting brackets, back-up brackets (where fitted) and their welded connections;
- locking hooks, securing pins, supporting brackets, back-up brackets (where fitted) and their welded connections;
- locking pins, supporting brackets, back-up brackets (where fitted) and their welded connections;
- locating and stopper devices and their welded connections.

Inner Bow Doors – double leaf side hinged

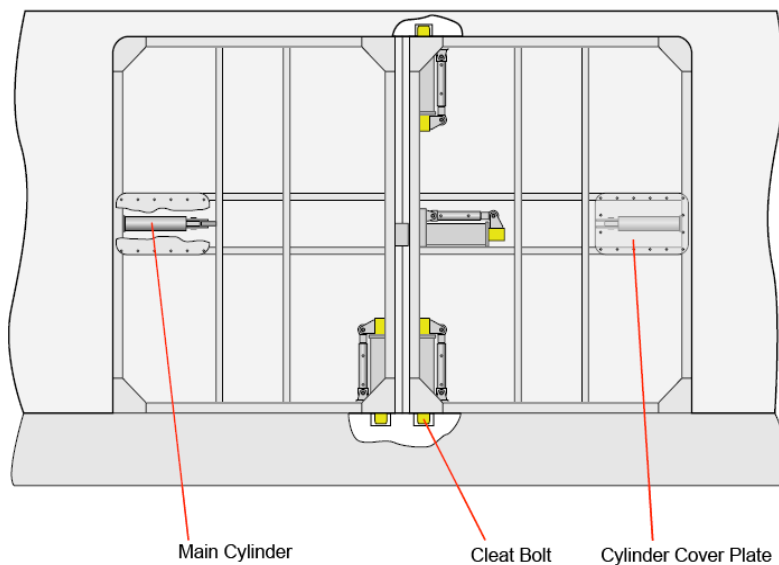

Illustration by courtesy of MacGREGOR Group

Bow Loading Ramp – stowed position, aft part (inner door) disconnected

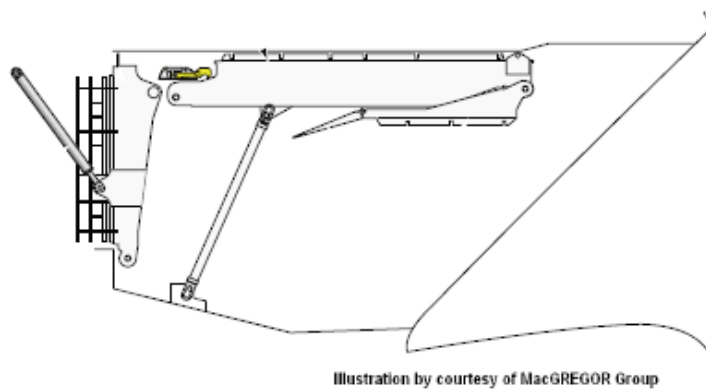
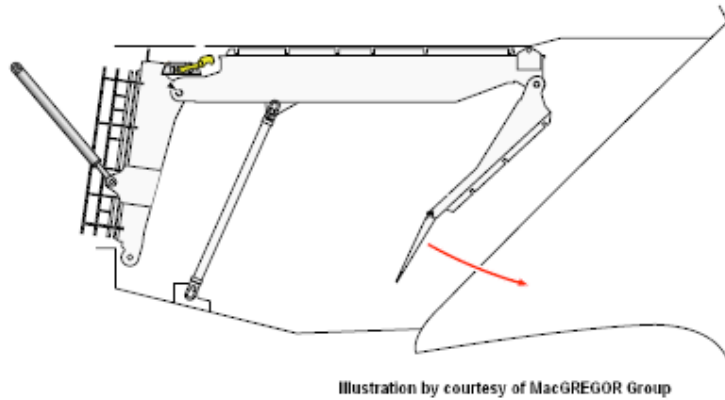
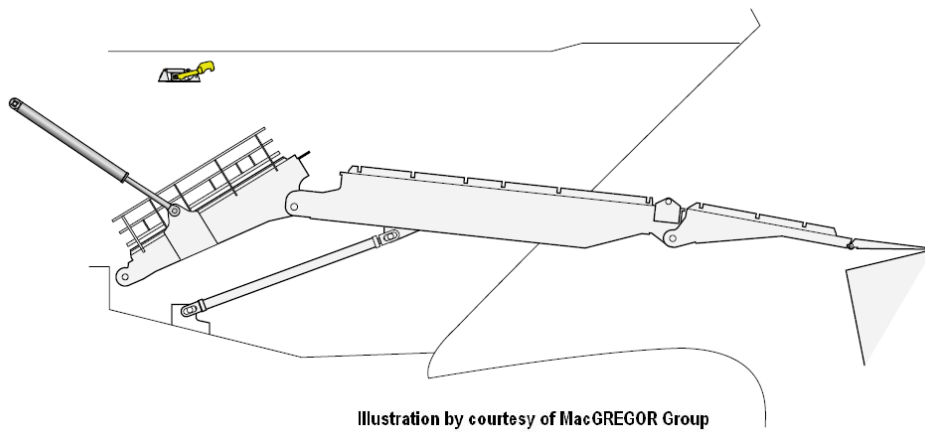

Illustration by courtesy of MacGREGOR Group

Bow Loading Ramp – beginning of opening sequence, aft part (inner door) connected by hydraulic hinge pin



Bow Loading Ramp – ramp partly extended to quay



Bow Loading Ramp – ramp fully extended to quay

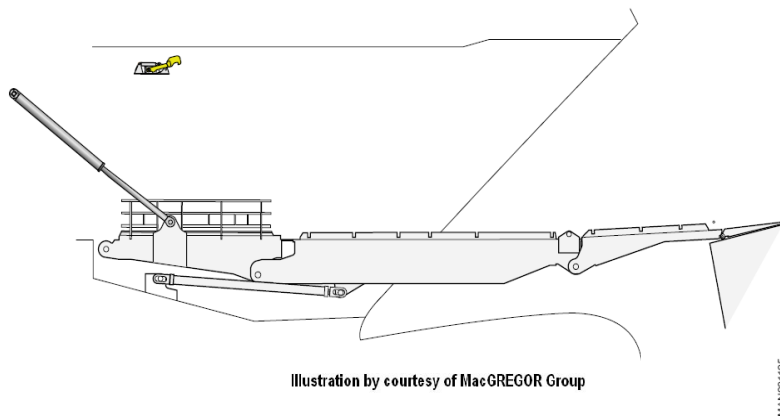

Inner Bow Door – single leaf top hinged, type 1

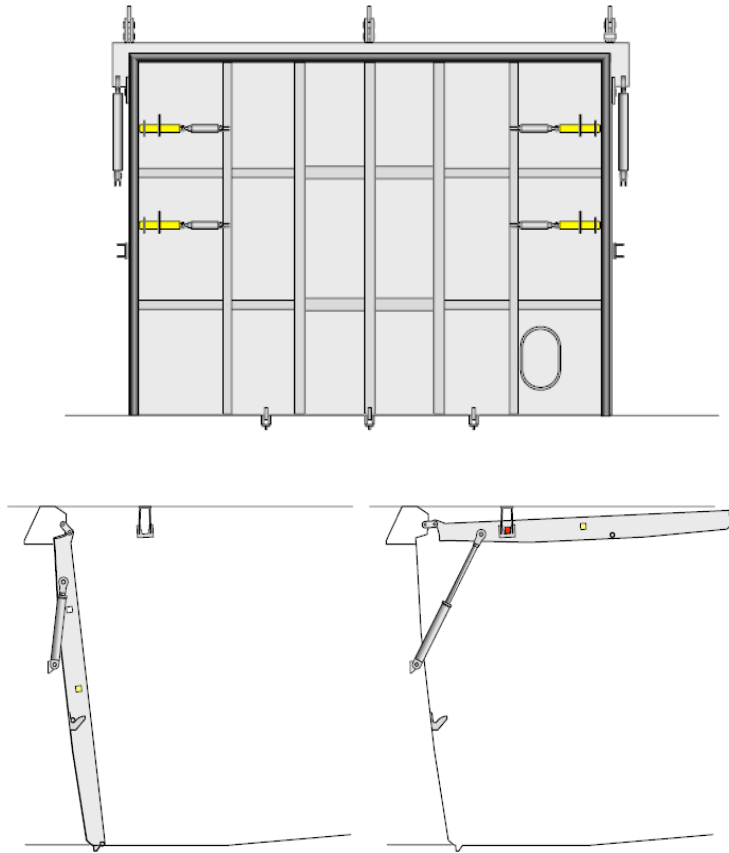

Inner Bow Door – single leaf top hinged, type 2

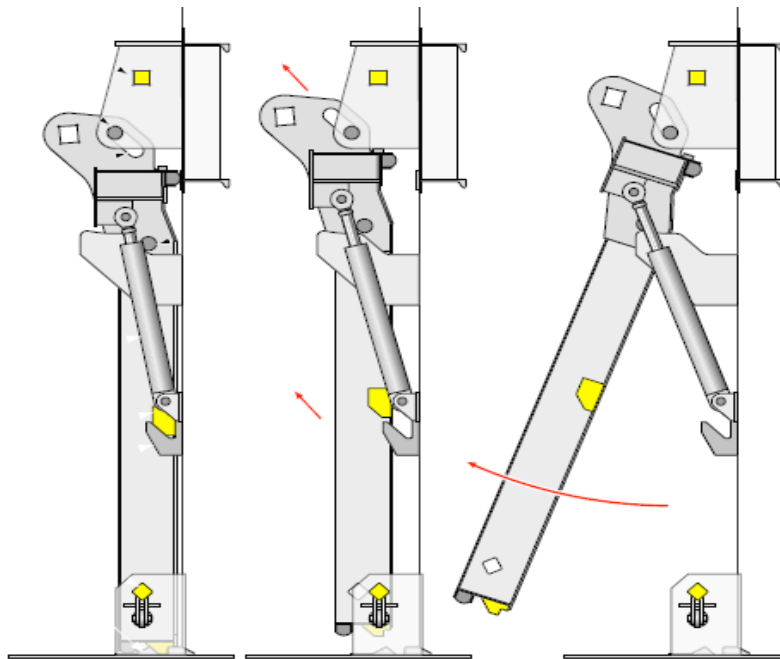

Illustration by courtesy of MacGREGOR Group

Bow Loading Ramp – side opening bow doors

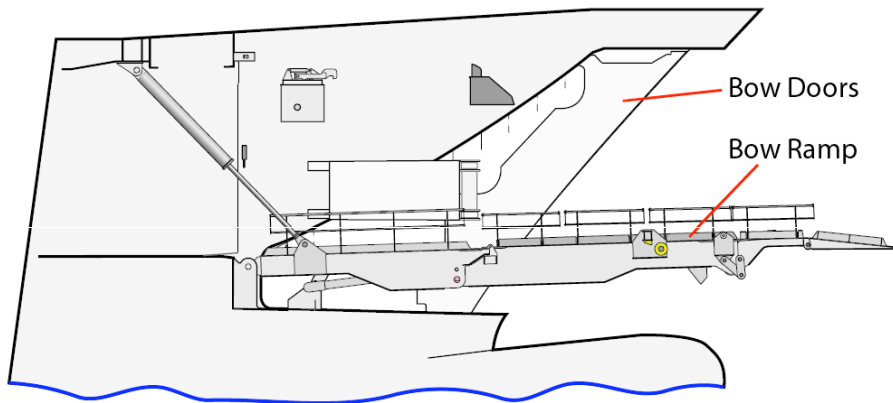

Illustration by courtesy of MacGREGOR Group

Bow side opening door – closed, side view

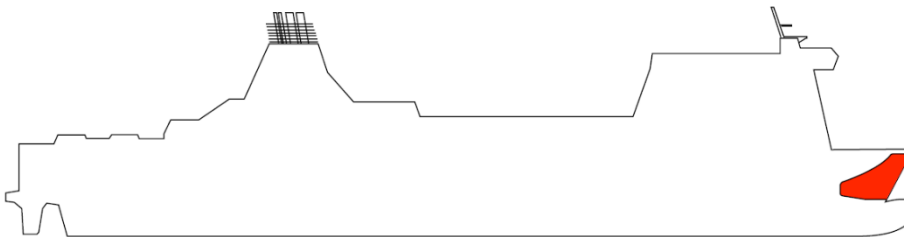

Illustration by courtesy of MacGREGOR Group

Bow side opening door – closed, top view

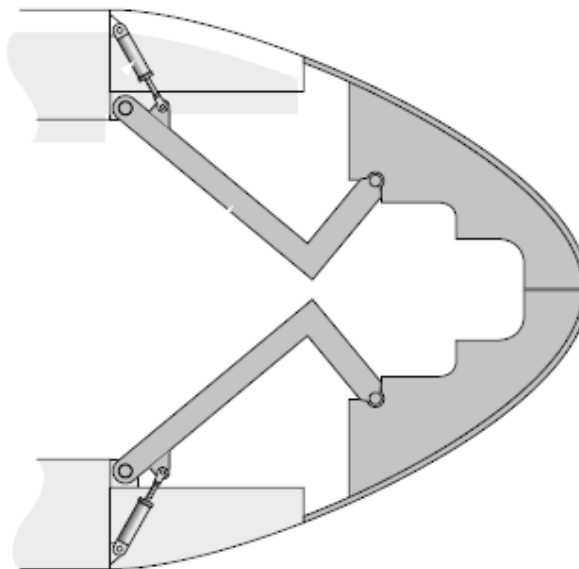
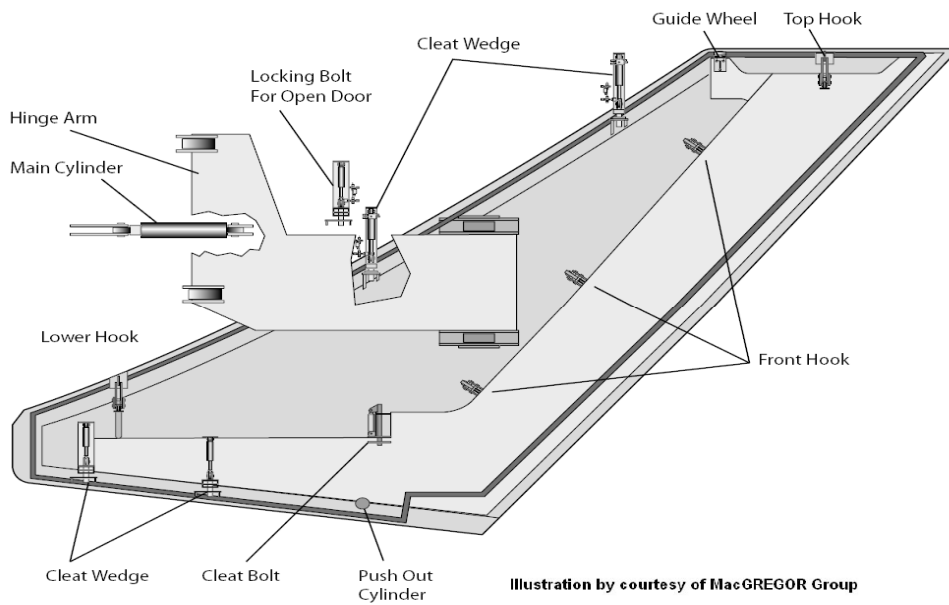
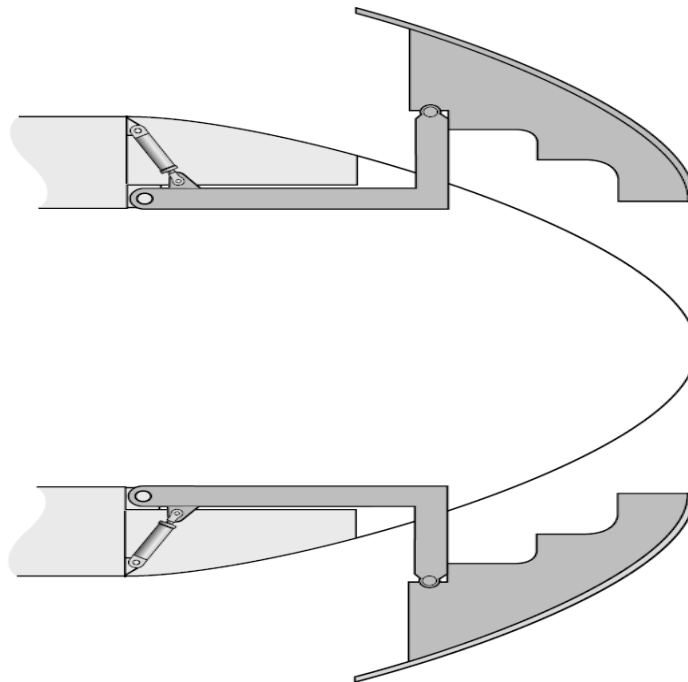

Illustration by courtesy of MacGREGOR Group

Bow side opening door – door panel details



Bow side opening door – open, top view



Bow Loading Ramp – visor type bow doors, general arrangement

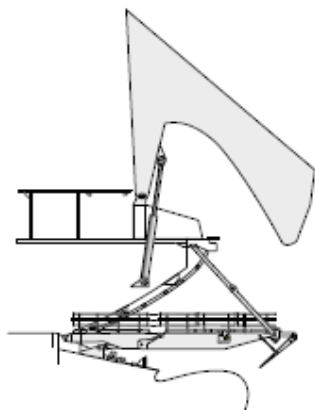

Illustration by courtesy of MacGREGOR Group

Bow Visor Door – general arrangement

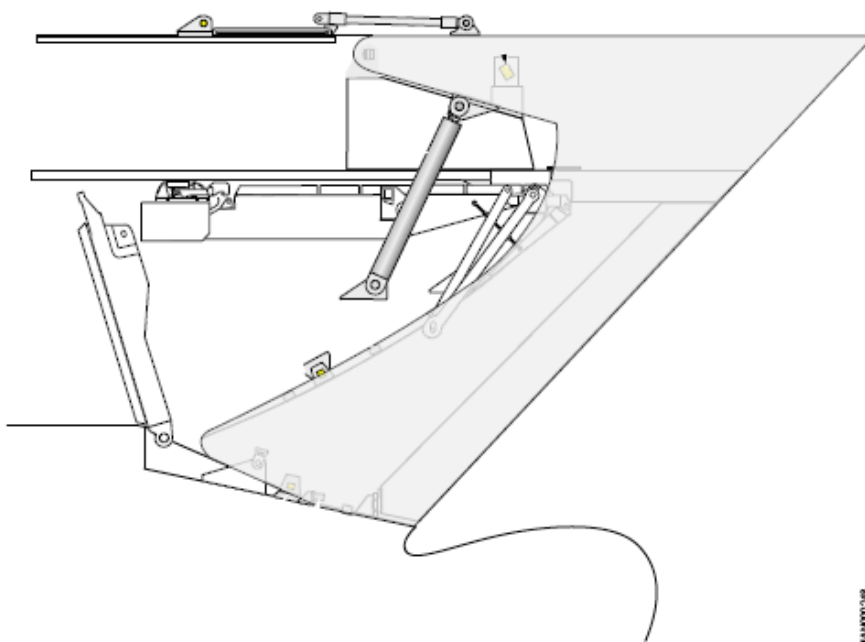

Illustration by courtesy of MacGREGOR Group

Cleating Hook 1

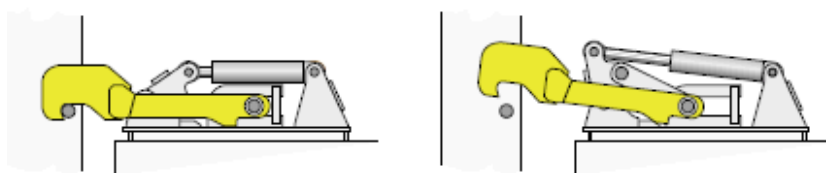

Illustration by courtesy of MacGREGOR Group

Cleating Hook 2

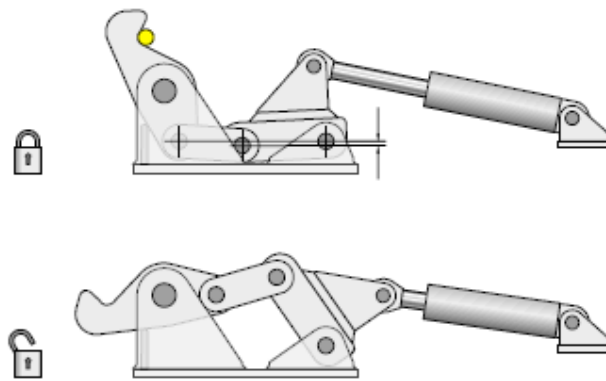

Illustration by courtesy of MacGREGOR Group

Cleating Wedge

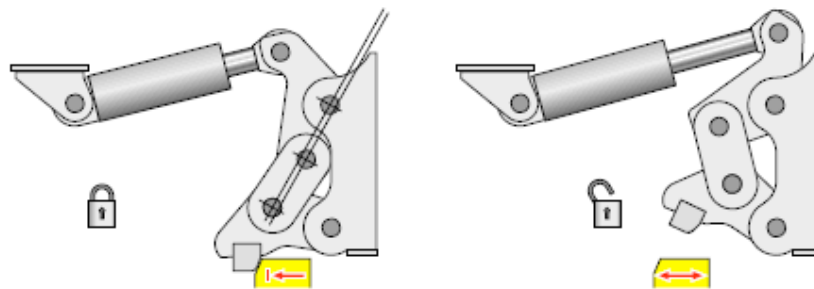

Illustration by courtesy of MacGREGOR Group

Hydraulic Actuators 1

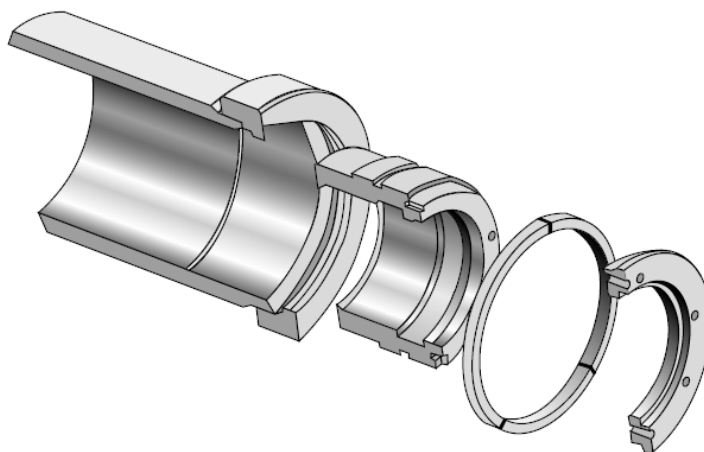

Illustration by courtesy of MacGREGOR Group

Hydraulic Actuators 2

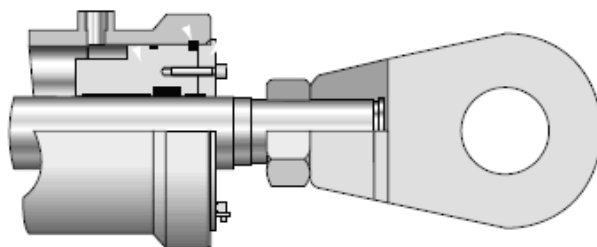

Illustration by courtesy of MacGREGOR Group

Hydraulic Actuators 3

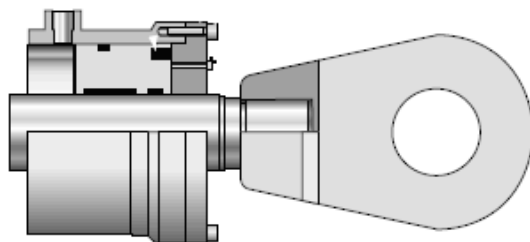

Illustration by courtesy of MacGREGOR Group

Hydraulic Actuators 4

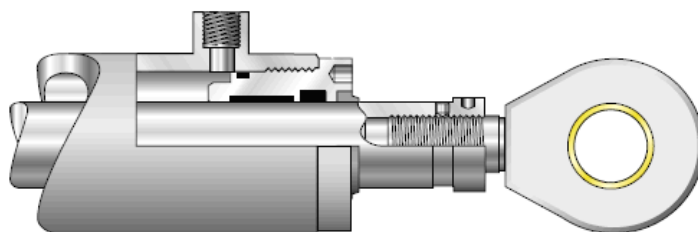
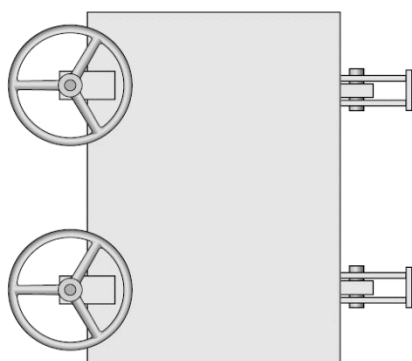

Illustration by courtesy of MacGREGOR Group

Control Panel – closing door



MAN000413

Illustration by courtesy of MacGREGOR Group

Bunker Door – closed, inside view

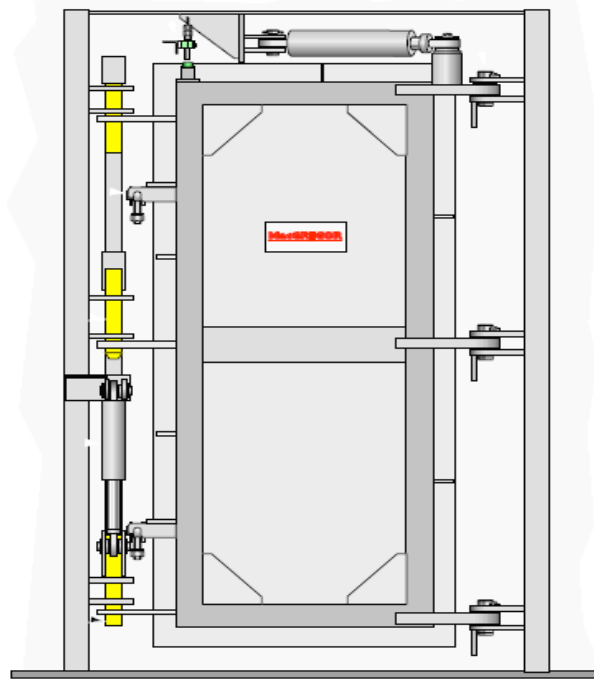

Illustration by courtesy of MacGREGOR Group

Bunker Door – Emergency Cleat

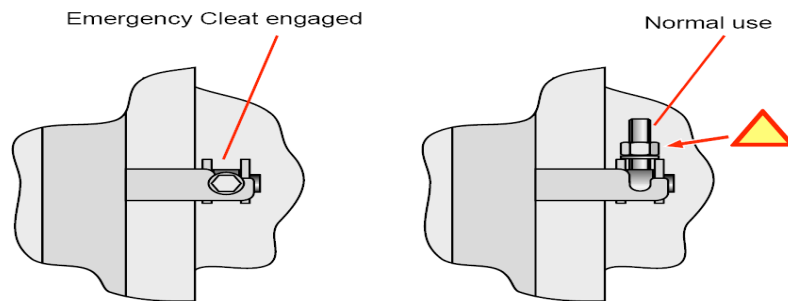

Illustration by courtesy of MacGREGOR Group

Bunker Port – type 1, closed, inside view

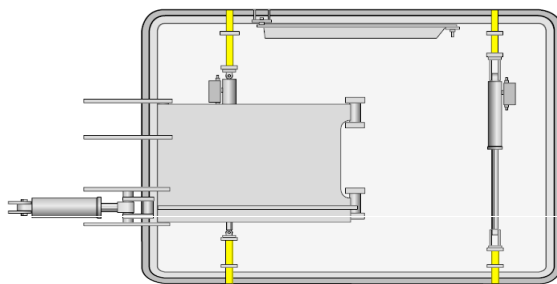

Illustration by courtesy of MacGREGOR Group

Bunker Port – type 2, closed, inside view

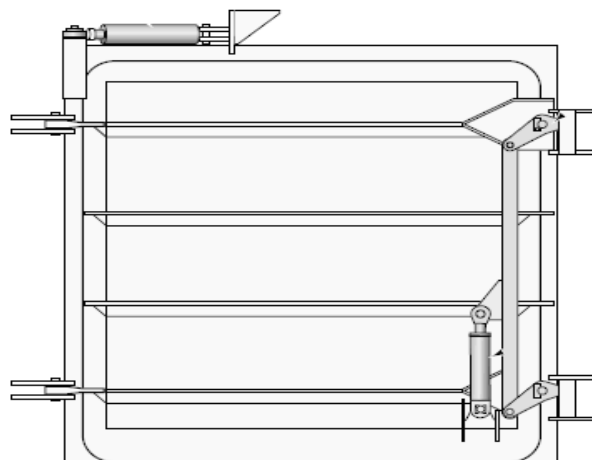

Illustration by courtesy of MacGREGOR Group

Cargo Door – closed, inside

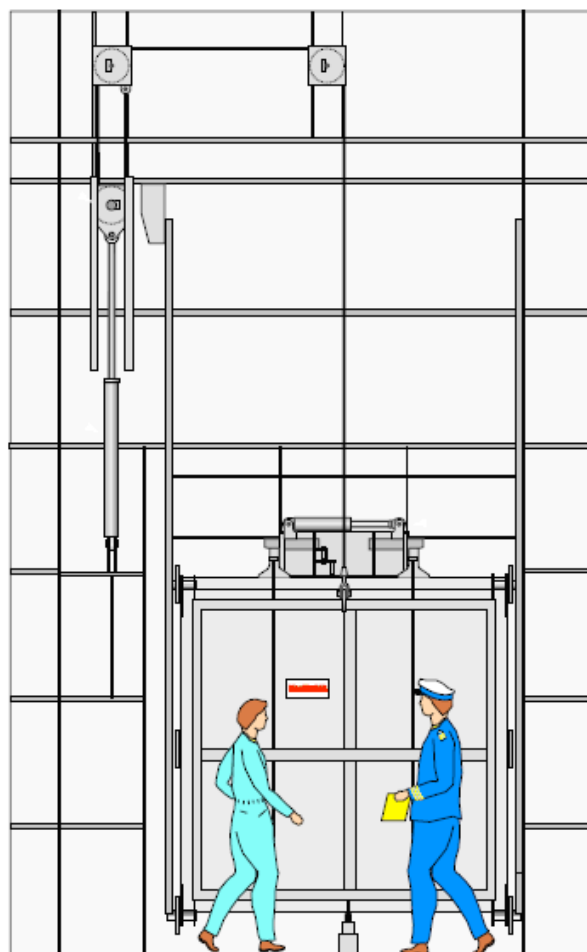

Illustration by courtesy of MacGREGOR Group

Cargo Door – open, inside

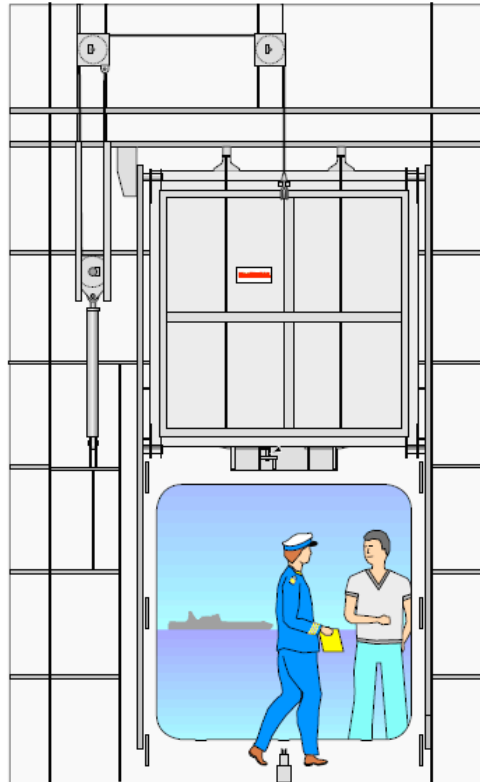

Illustration by courtesy of MacGREGOR Group

Cargo Door – principle of function

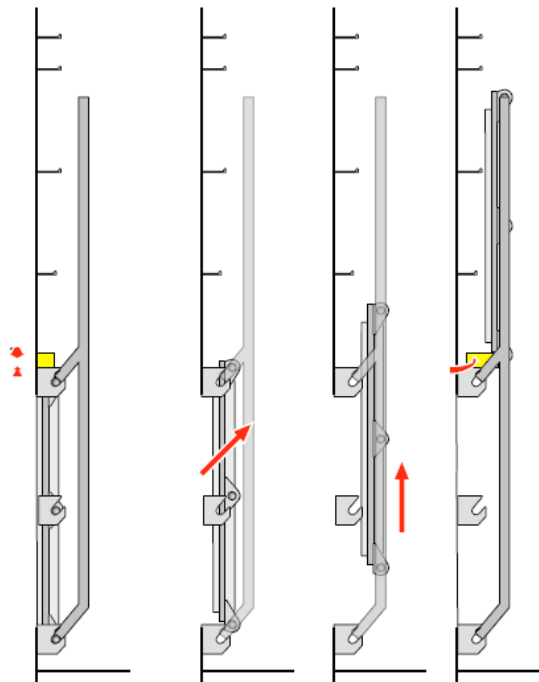

Illustration by courtesy of MacGREGOR Group

Cargo Door – type side hydraulic securing device disengaged

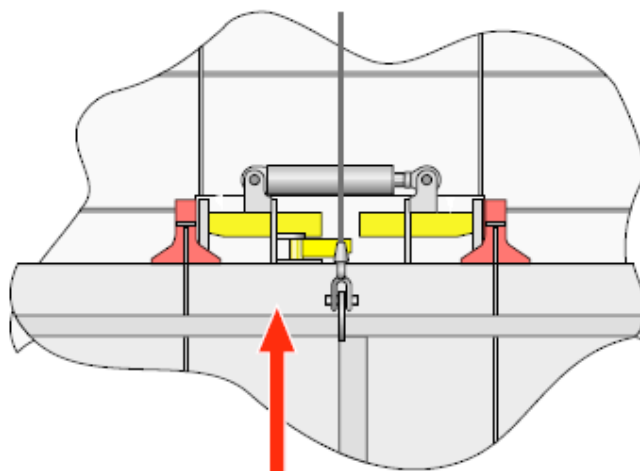

Illustration by courtesy of MacGREGOR Group

Cargo Door – top side hydraulic securing device engaged

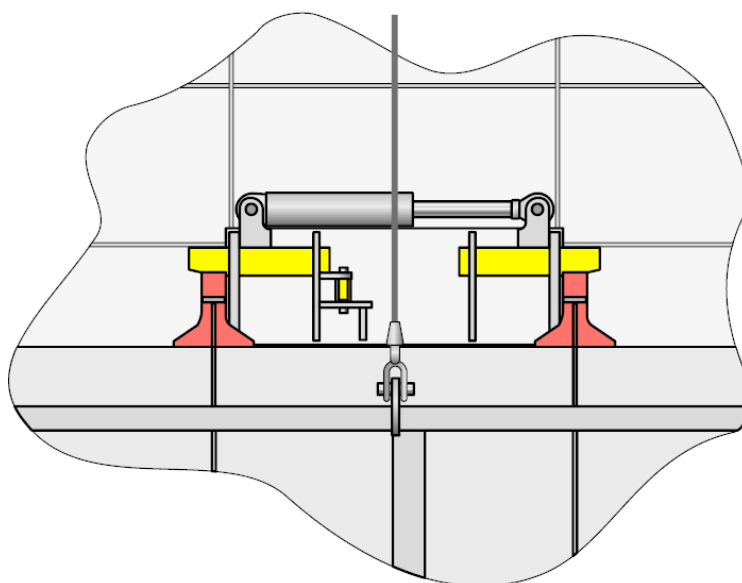

Illustration by courtesy of MacGREGOR Group

Side Shell Door – double leaf, closed, inside view

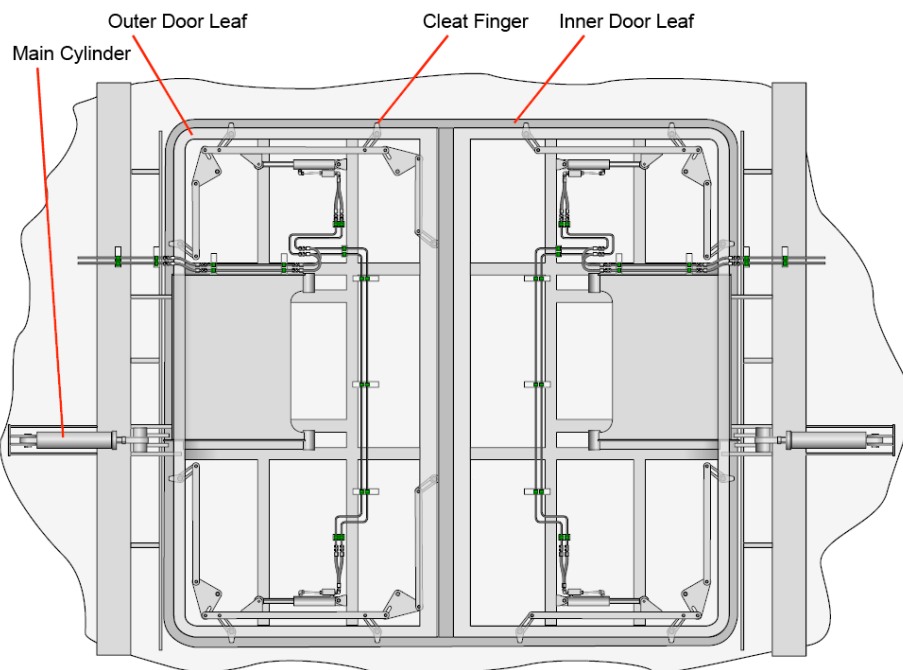

Illustration by courtesy of MacGREGOR Group

Side Shell Door – double leaf, closed, top view

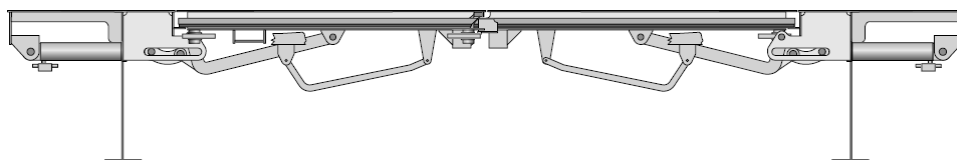

Illustration by courtesy of MacGREGOR Group

Side Shell Door – double leaf, fully opened, top view

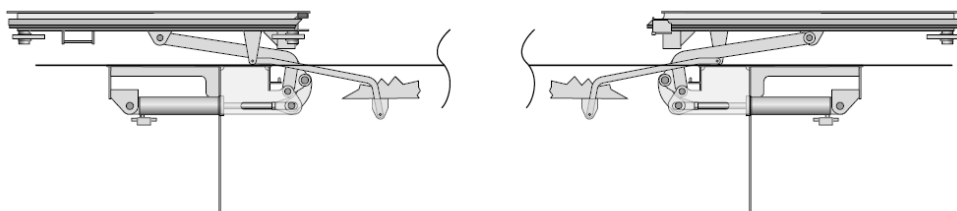

Illustration by courtesy of MacGREGOR Group

Side Shell Door – double leaf, half opened, top view

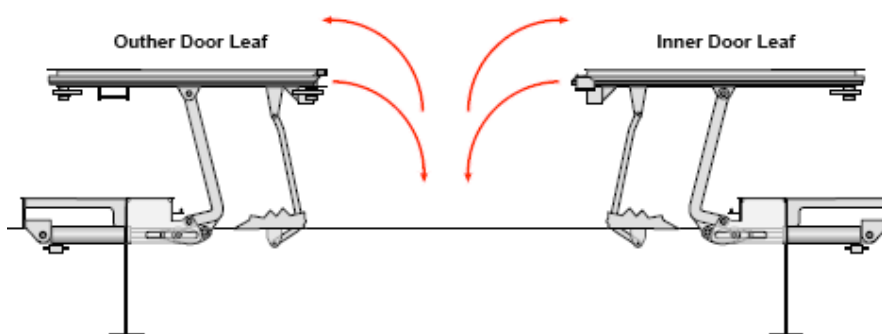

Illustration by courtesy of MacGREGOR Group

Pilot Door – inside view

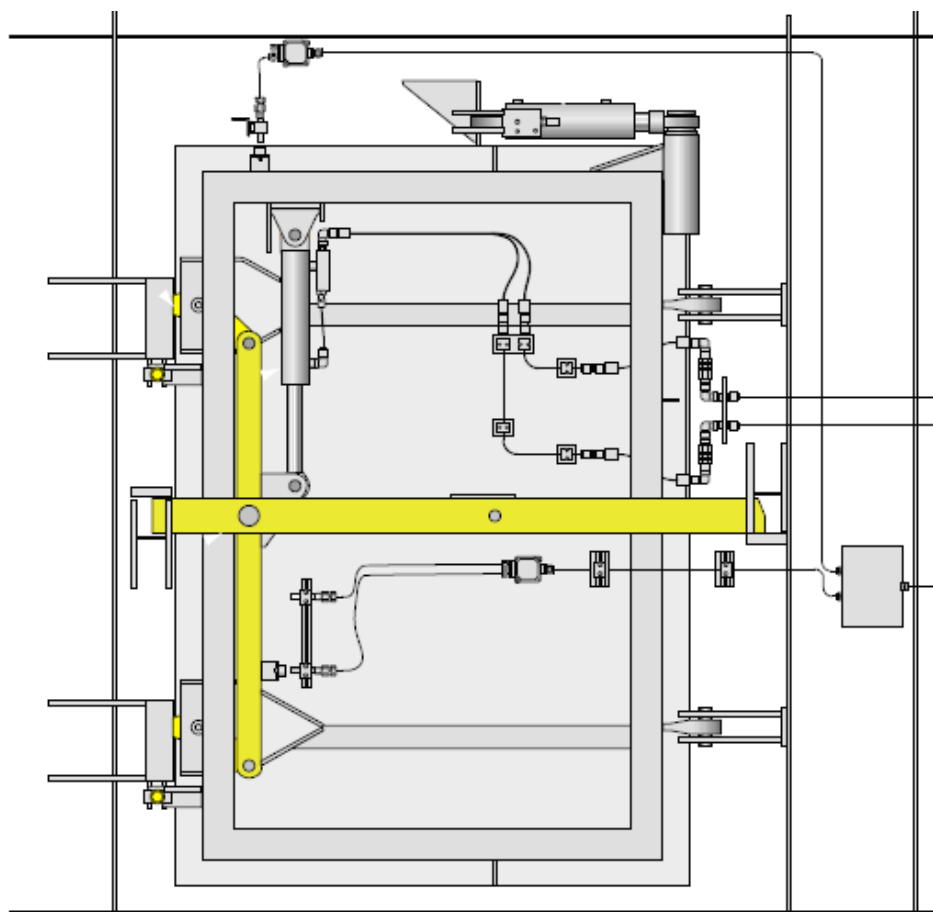

Illustration by courtesy of MacGREGOR Group

Side Ramp – front view

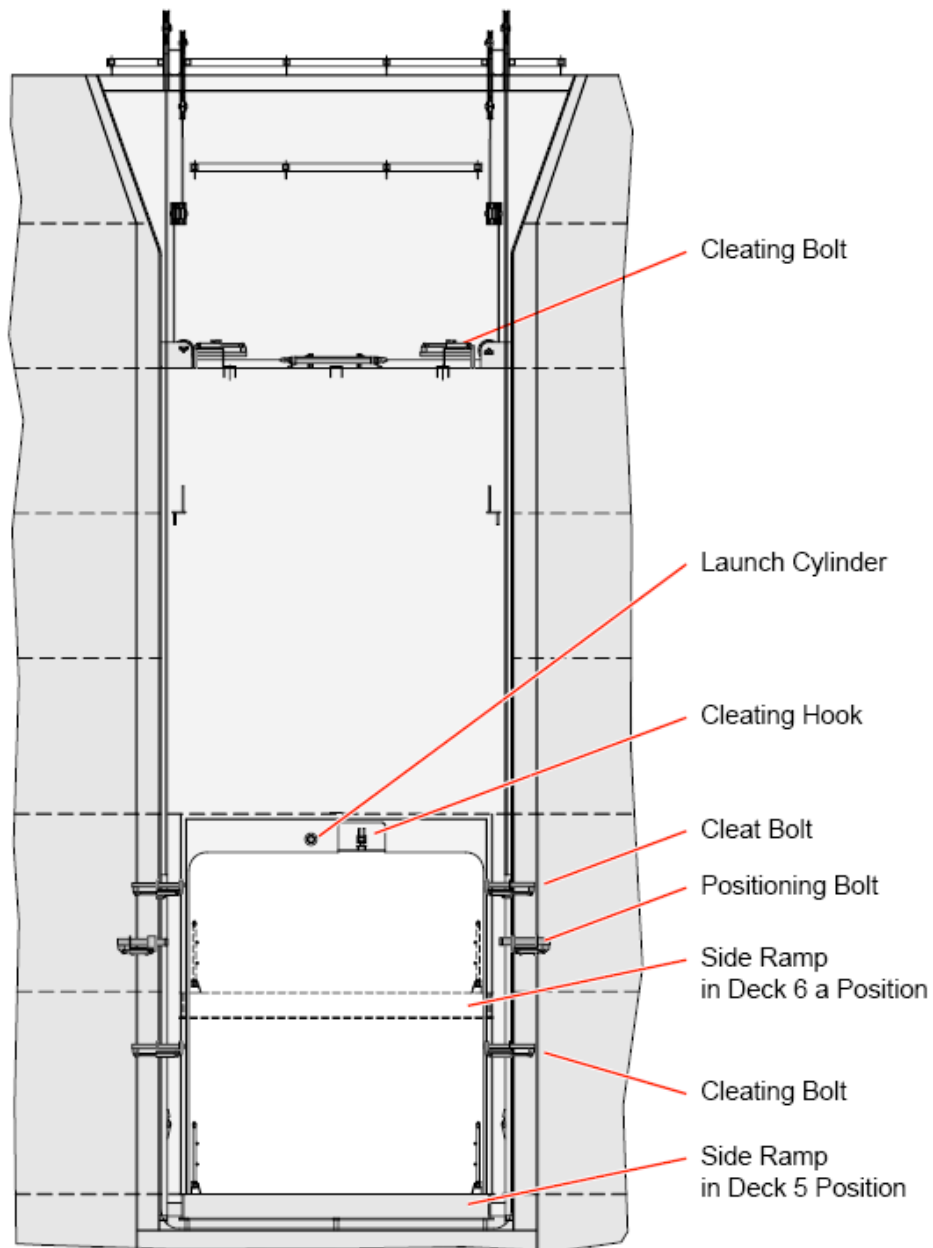

Illustration by courtesy of MacGREGOR Group

Side Ramp – side view

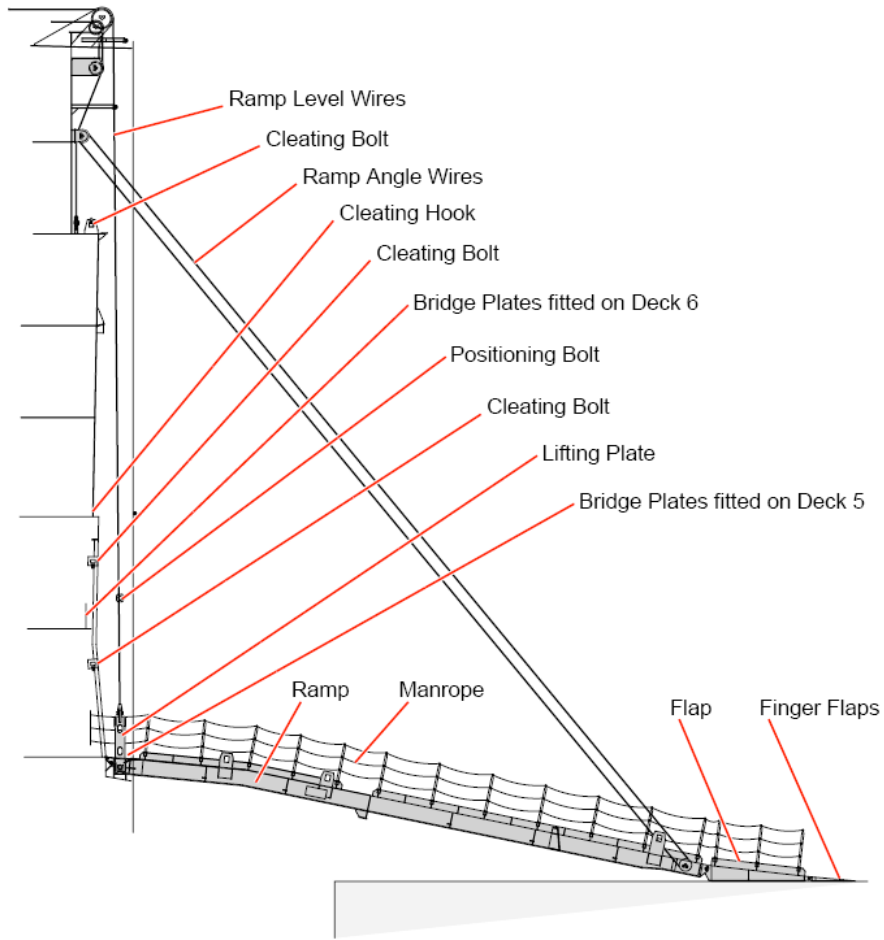

Illustration by courtesy of MacGREGOR Group

Side Ramp – top view

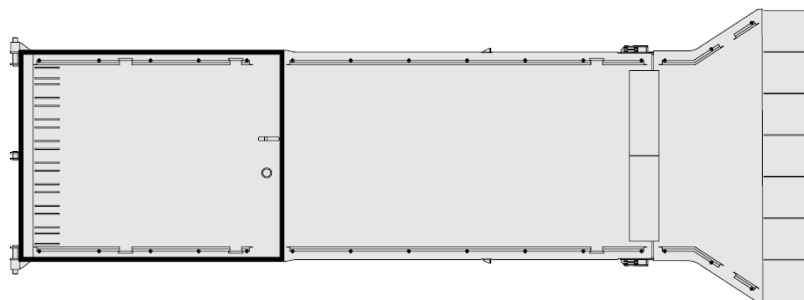

Illustration by courtesy of MacGREGOR Group

Stern Door – single leaf, closed, car carrier type

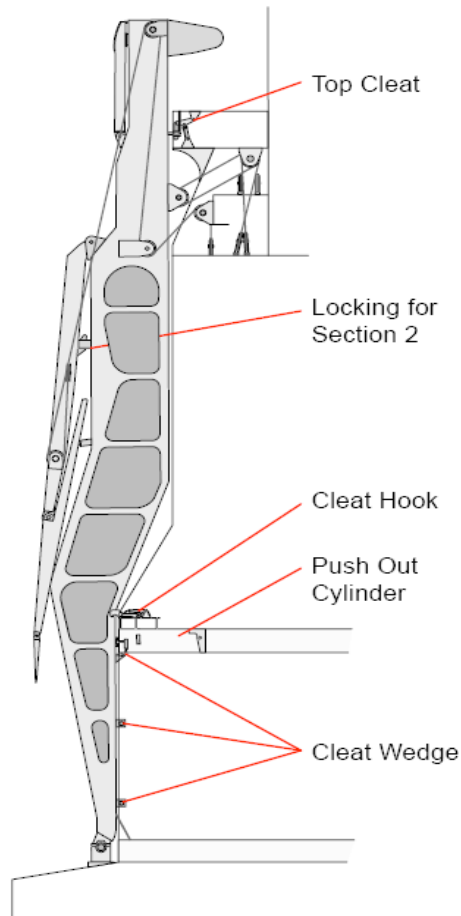

Illustration by courtesy of MacGREGOR Group

Stern Door – single leaf, open, car carrier type, top view

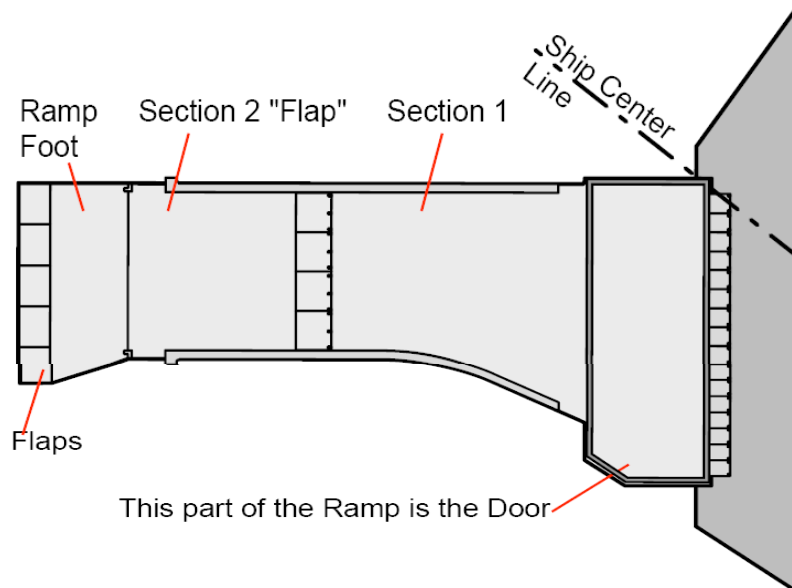

Illustration by courtesy of MacGREGOR Group

Stern Door – single leaf, open, car carrier type

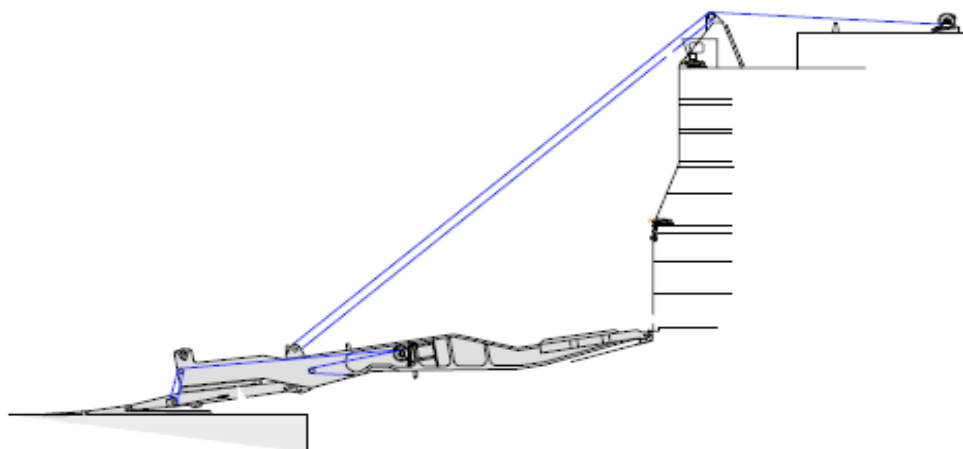

Illustration by courtesy of MacGREGOR Group

Stern Door – double leaf, open, typical cleating arrangement

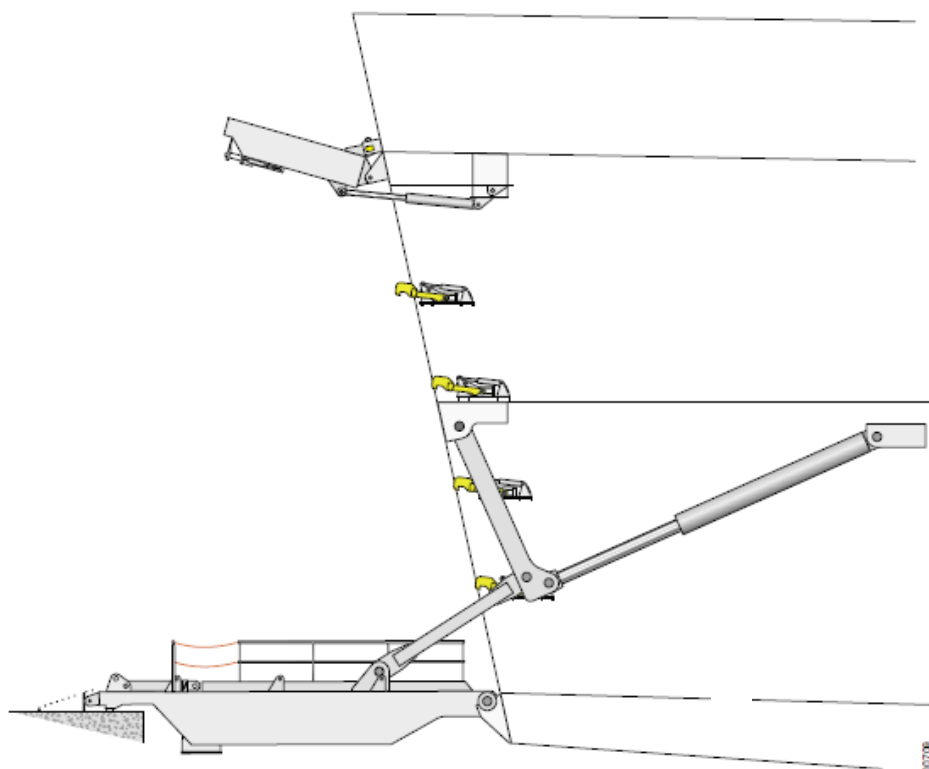

Illustration by courtesy of MacGREGOR Group

Stern Door – single leaf, open typical cleating arrangement, type 1

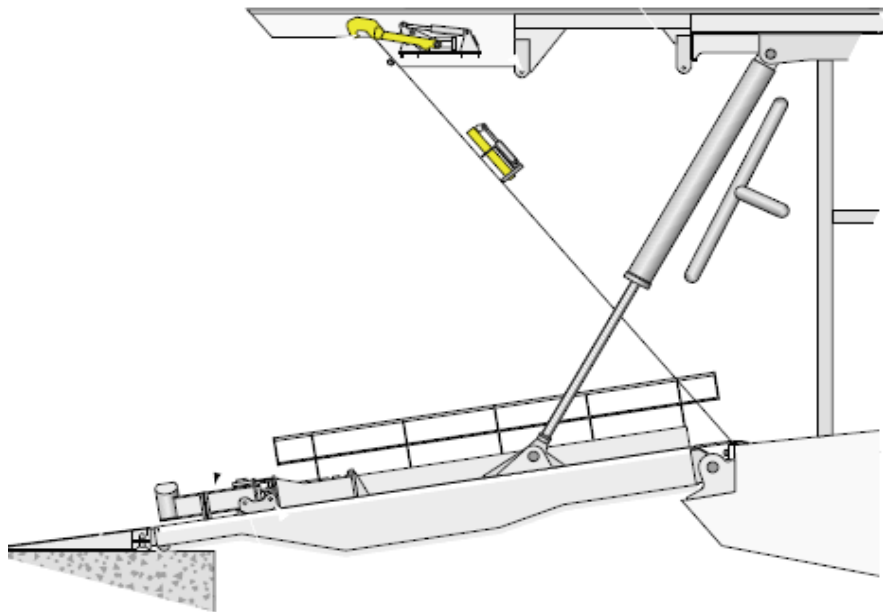

Illustration by courtesy of MacGREGOR Group

Stern Door – single leaf, open, typical cleating arrangement, type 2

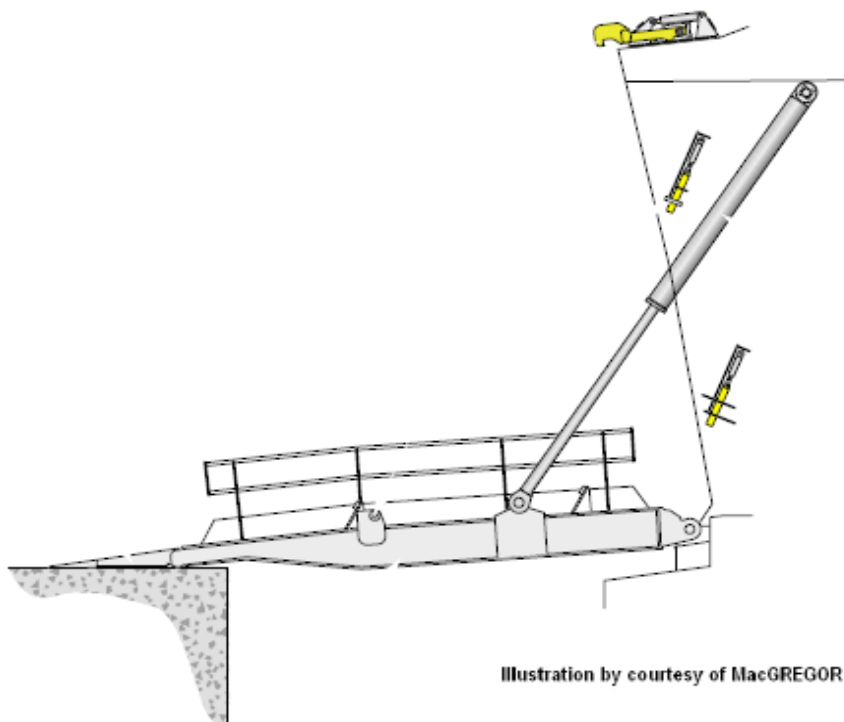

Illustration by courtesy of MacGREGOR Group

Stern Door – single leaf, closed, inside view, typical cleating arrangement, type 3

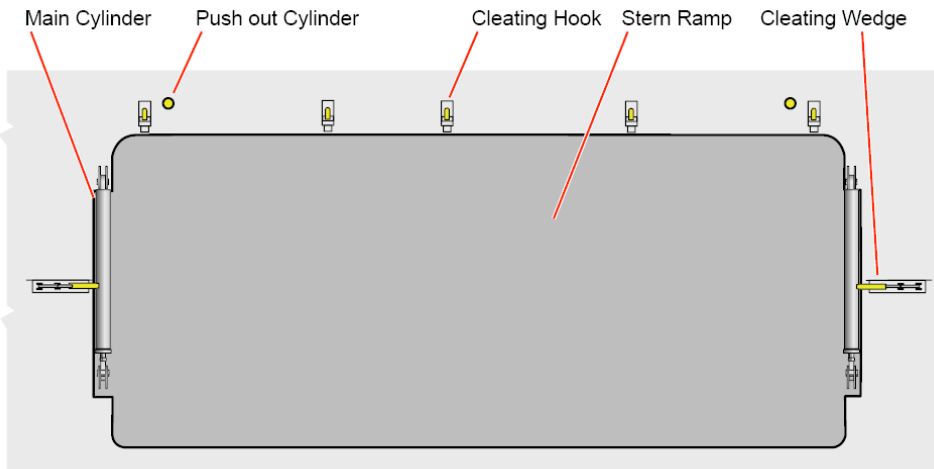

Illustration by courtesy of MacGREGOR Group

Stern Door – single leaf, closed, typical cleating arrangement, type 3

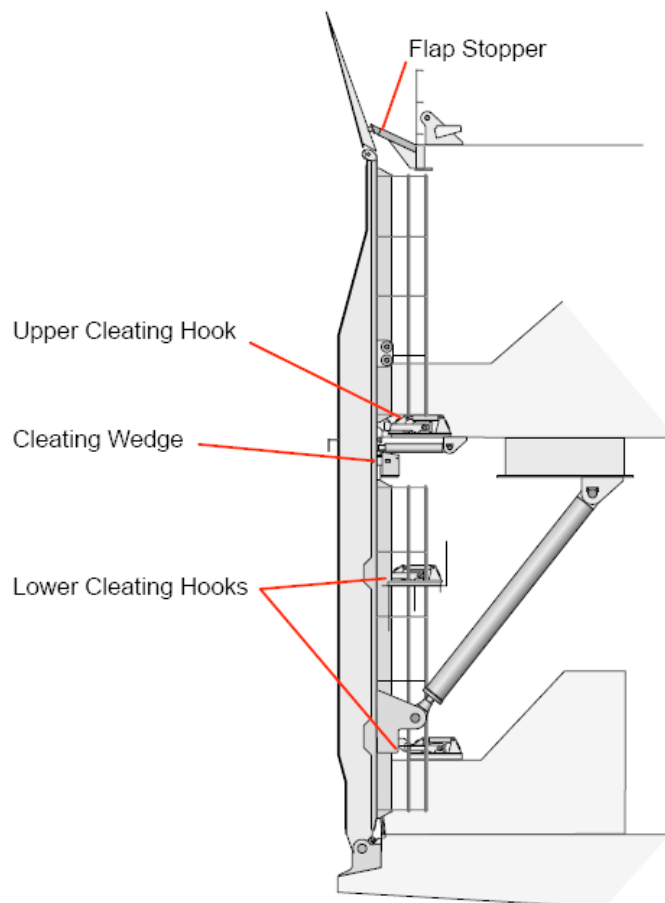

Illustration by courtesy of MacGREGOR Group

Stern Door – single leaf, open, push-out cylinder arrangement

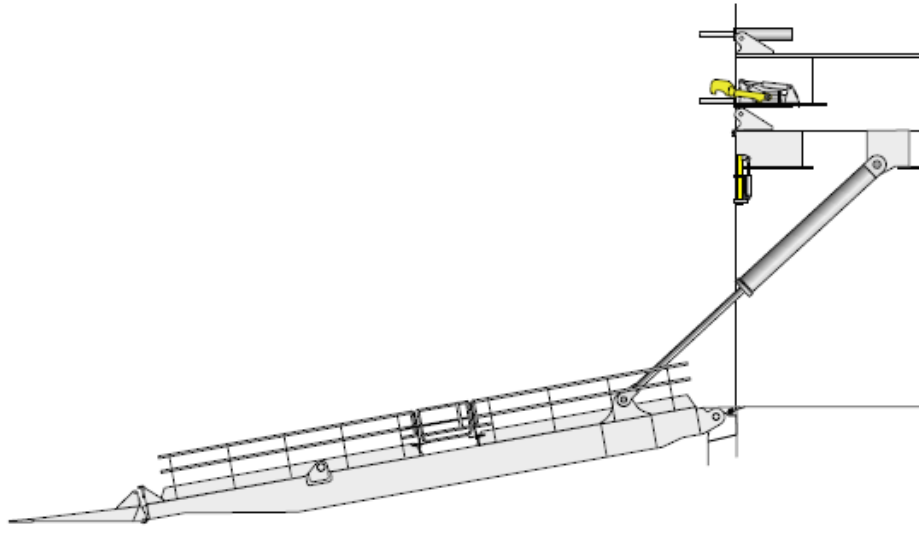

Illustration by courtesy of MacGREGOR Group

Stern Door – single leaf, open, typical cleating arrangement, type 3

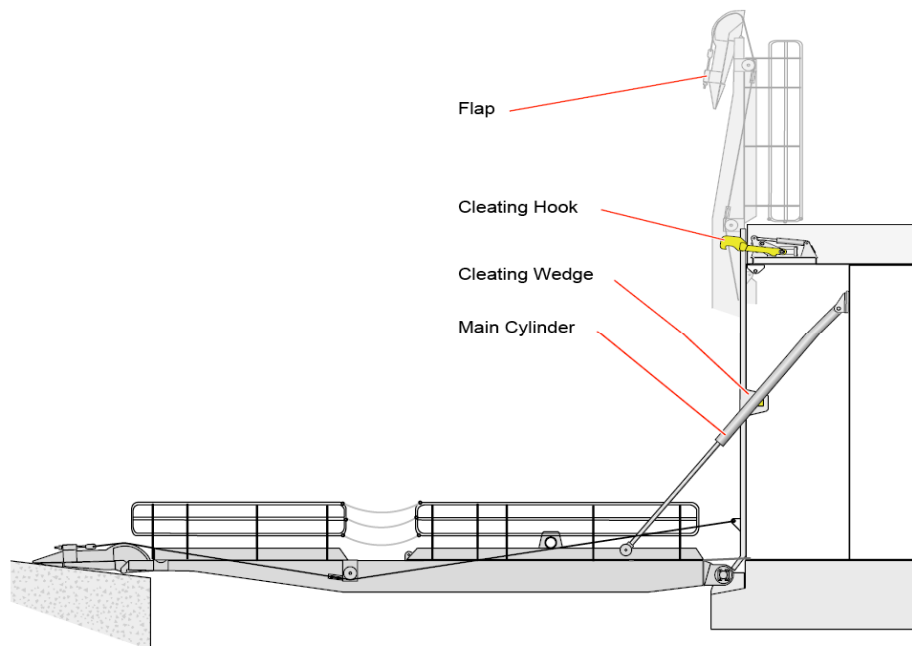

Illustration by courtesy of MacGREGOR Group