

Polski Rejestr Statków

RULES

PUBLICATION NO. 106//P

ECO CLASS RULES

2017
January

Publications P (Additional Rule Requirements) issued by Polski Rejestr Statków complete or extend the Rules and are mandatory where applicable.



GDĄŃSK

Publication No. 106 /P – Eco Class Rules – January 2017, is an extension of the requirements contained in *Part I – Classification Regulations of the Rules for the Classification and Construction of Sea-Going Ships*, as well as in all other PRS Rules, in which reference to the *Publication* has been made.

The *Publication* was approved by the PRS Executive Board on 13 December 2016 and enters into force on 1 January 2017.

The present *Publication* replaces *Publication No. 106 /P – Eco Class Rules – 2014*.

© Copyright by Polski Rejestr Statków S.A., 2017

PRS/OP, 12/2016

CONTENTS

Page

1 General	5
2 Additional mark in the symbol of class	5
2.1 General	5
2.2 Types of Additional Marks of Ecological Ship	5
3 ECO SEA	6
3.1 Prevention of Sea Pollution by Oil (MARPOL Annex I)	6
3.2 Prevention of Sea Pollution by Noxious Liquid Substances in Bulk (MARPOL Annex II)	7
3.3 Prevention of Sea Pollution by Harmful Substances Carried by Sea in Packaged Form (MARPOL Annex III)	8
3.4 Prevention of Sea Pollution by Sewage (MARPOL Annex IV)	8
3.5 Prevention of Sea Pollution by Garbage (MARPOL Annex V)	9
4 ECO AIR	10
4.1 Nitrogen Oxides (NO _x)	10
4.2 Sulphur Oxides (SO _x).....	11
4.3 Ozone Depleting Substances	11
4.4 Volatile Organic Compounds (VOCs).....	13
4.5 Ships Energy Efficiency	13
4.6 Incineration Equipment	14
4.7 Electrical Shore Power Supply Systems	14
5 ECO EF	19
5.1 Basic Requirements	19
5.2 Basic Technical Documentation	19
5.3 Additional Requirements	19
5.4 Additional Technical Documentation	19
6 ECO BWM	19
Definitions.....	19
6.1 Basic Requirements	20
6.2 Basic Technical Documentation	20
6.3 Additional Technical Documentation	20
6.4 Installation	20
6.5 Additional requirements for tankers	21
6.6 Ventilation	22
6.7 Special requirements.....	22
6.8 Automation	23
7 ECO REC	24
7.1 Basic Requirements	24

1 GENERAL

1.1.1 At the Owner's request, PRS may assign the additional mark in the symbol of class to a new or an existing ship, as well as to confirm, renew, withdraw or reinstate additional mark in the symbol of class of an existing ship classed with PRS.

1.1.2 Additional mark in the symbol of class of a ship is confirmed by the *Certificate of Class*.

1.1.3 In the Certificate of Class, the main symbol of class with additional marks, as specified in 2, is given.

2 ADDITIONAL MARK IN THE SYMBOL OF CLASS

2.1 General

2.1.1 Additional marks in the symbol of class indicate obligatory requirements or limitations relevant to the ship type or its operation ability, as well as additional ship structure or adaptation features.

2.1.2 Additional marks are affixed to the symbol of class upon compliance of the requirements specified in this *Rules*.

2.1.3 PRS may assign to the ship additional marks in the symbol of class if considers it technically justified. Compliance with the requirements specified in this Rules and the ability to assign to the ship additional marks is every time verified by the PRS.

2.2 Types of Additional Marks of Ecological Ship

2.2.1 Mark Indicating Ship's Adaptation Features to Prevent Sea Pollution

If structure features and/or equipment of the ship comply with the relevant requirements specified in Chapter 3 of these *Rules*, the following mark is affixed in the symbol of class:

ECO SEA

2.2.2 Mark Indicating Ship's Adaptation Features to Prevent Air Pollution

If structure features and/or equipment of the ship comply with the relevant requirements specified in Chapter 4 of these *Rules*, the following mark is affixed in the symbol of class:

ECO AIR

2.2.3 Mark Indicating Ship's Adaptation Features to Ships Energy Efficiency

If structure features and/or equipment of the ship comply with the relevant requirements specified in Chapter 5 of these *Rules*, the following mark is affixed in the symbol of class:

ECO EF

2.2.4 Mark Indicating Ship's Adaptation Features to Control and Management of Ships' Ballast Water and Sediments

If structure features and/or equipment of the ship comply with the relevant requirements specified in Chapter 6 of these *Rules*, the following mark is affixed in the symbol of class:

ECO BWM

2.2.5 Mark Indicating Ship's Adaptation Features to Safe and Environmentally Sound Recycling

If the ship comply with the relevant requirements specified in Chapter 7 of these *Rules*, the following mark is affixed in the symbol of class:

ECO REC

3 ECO SEA

3.1 Prevention of Sea Pollution by Oil (MARPOL Annex I)

3.1.1 Basic Requirements

To maintain an *International Oil Pollution Prevention Certificate* (or a *Statement of Compliance* in cases where Annex I to the *MARPOL Convention* is not applicable) survey shall be conducted in accordance with Surveys for the International Oil Pollution Prevention Certificate, Chapter 8 of Supplement to the *Rules for Statutory Survey of Sea-going Ships, Part I* and a special attention shall be paid on the following:

- .1 Oil content of oily bilge water discharged from machinery spaces shall not exceed 15ppm under any circumstances and it shall pass through oil filtering equipment with arrangements to ensure that any discharge of oily mixtures is automatically stopped in cases where the oil content of effluents exceeds 15 ppm.
- .2 Segregated oil residues (sludge) tanks shall be installed in addition to sludge tanks for the onboard incineration of leaked oil and waste oil.
- .3 Manholes or access holes of sufficient size shall be provided at such positions so that each part of the tank can be cleaned without difficulty, and appropriate means to facilitate the drainage and discharge of oil residues shall be provided.
- .4 Fuel oil pipes shall be entirely separate from any other pipes including the discharge piping from bilge storage tanks and sludge tanks.
- .5 Standard discharge connections shall be provided in the discharge pipelines of sludge tanks and bilge storage tanks in accordance with the provisions given in the *Rules for Statutory Survey of Sea-going Ships, Part IX – Environmental Protection*.
- .6 High level alarms/overflow systems shall be provided in fuel tanks, fuel oil settling and service tanks. (Sounding pipes are not considered acceptable.)
- .7 Metallic drip trays with sufficient depth shall be provided at the contact points for the loading and discharging of oils other than cargo oil.
- .8 High level alarms, overflow control devices or level monitoring systems operable at control positions shall be provided in cargo oil tanks. (Sounding pipes are not considered acceptable.)
- .9 Sea suction pipes and discharge pipes for permanent ballast tanks shall not be connected to the suction and discharge pipes of cargo tanks.
- .10 In cases where sea suction pipes for ballasting purposes are connected to cargo oil pipes, stop valves shall be provided between the sea suction valves and the cargo oil piping.
- .11 Metallic drip trays with sufficient depth shall be provided at the manifold connections of cargo pipes. The drains of such drip trays shall be led to drain tanks or other suitable oil drainage equipment.
- .12 Fuel oil tanks and piping shall comply with Regulation 12A, Annex I to the *MARPOL Convention*. The minimum protection distance shall be 1.2 times as much as the required value based on provisions 6 to 8 of Regulation 12A.
- .13 All discharges of oily bilge water and oil residue (sludge) shall be recorded in the *Oil Record Book*.
- .14 Oil discharge monitoring and control system for oil tanker shall meet the requirements specified in *IMO Resolution MEPC.108(49)* and *MEPC.240(65)*.

3.1.2 Basic Technical Documentation

- .1 *Certificate* or *Statement of Compliance* (if already provided).
- .2 Capacity and piping arrangement of bilge water holding tanks, oil residues (sludge) tanks.
- .3 Particulars of oil discharge prevention systems (it may be an operational manual for the oil discharge monitoring and control system (ODM manual) related to cargo, and the bilge separator manufacturer's instruction manual for systems related to engine room bilges).
- .4 *Shipboard oil pollution emergency plan (SOPEP)*.
- .5 Arrangement of cargo and ballast water tanks (only for tankers).
- .6 Plan views of cargo and ballast water arrangement systems, including systems to prevent the overfilling of cargo tanks (tankers only).
- .7 Arrangement of tanker cargo manifolds, associated drip trays and discharge systems (tankers only).

- .8 STS Operations Plan, prescribing how to conduct ship to ship operations and containing guidance for the prevention of oil pollution during such operations. (applicable only for tankers).
- .9 ODM Manual. Manual of oil discharge monitoring and control system used for monitoring of oil and each individual bio-fuel blend containing 75 per cent or more of petroleum oil.

3.1.3 Additional Requirements

- .1 The Integrated Bilge Water Treatment System specified in *Revised guidelines for systems for handling oily wastes in machinery spaces of ships incorporating guidance notes for an integrated bilge water treatment system (IBTS)* of MEPC.1/Cir.642 with amendments, shall be installed.
- .2 Oil bilge water originated from engine room, oil residues (sludge), boiler drainage waste water shall be treated in oily water separators or transferred to shore reception facilities.
- .3 Air seal construction or equivalent arrangements such as fresh water seal shall be such that stern tube lubricating oil does not come in contact with seawater.
- .4 Procedures related to handling oil and oil residues (sludge) shall be prepared, and the handling work shall be performed according to those procedures. Such procedures shall include descriptions of at least the following:
 - .1 The loading, shifting, discharging or disposing of fuel oil, lubricating oil, and cargo oil.
 - .2 Discharge or disposal of oil residues in sludge tanks and oil residues (sludge) tanks, and the oily mixtures included in the bilge water of bilge storage tanks and engine rooms.
 - .3 Procedure for the recovery of oil that has leaked into decks.

3.1.4 Additional Technical Documentation

- .1 Relevant drawings of the integrated bilge system mentioned in 3.1.3.1, if installed.
- .2 Stern tube air seal construction drawings.

3.2 Prevention of Sea Pollution by Noxious Liquid Substances in Bulk (MARPOL Annex II)

3.2.1 Basic Requirements

If applicable, to maintain an *International Pollution Prevention Certificate for the Carriage of Noxious Liquid Substances in Bulk* or *International Certificate of Fitness for the Carriage of Dangerous Chemicals in Bulk* or *International Certificate of Fitness for the Carriage of Liquefied Gases in Bulk*, survey shall be conducted in accordance with Surveys for the International Pollution Prevention Certificate for the Carriage of Noxious Liquid Substances in Bulk, Chapter 9 of Supplement to the *Rules for Statutory Survey of Sea-Going Ships, Part I* and a special attention shall be paid on the following:

- .1 Each tank designated for the carriage of substances falling into Category X, Y or Z shall be provided with pumping and piping arrangements to ensure, through testing, that in the immediate vicinity of the tank's suction point and in the tank's associated piping does not retain an amount of residue in excess of 75 l for ships constructed on or after 1 January 2007.
- .2 All cargo manifolds shall be provided with drip trays with arrangements for draining. The drip trays shall have the following minimum dimensions:
 - length: beyond forward and aft ends of the manifold,
 - width: at least 1.8 m, though such that spill tray extends at least 1,2 m outboard of the end of the manifold flange,
 - depth: minimum depth 0.3 m.
- .3 Discharge of cargo residues into the sea shall be limited as far as practicable. Discharge and deliveries to shore shall be documented in the *Cargo record book*. Maximum allowable remaining cargo quantity shall be 0.075 m³ for all pollution categories defined in *MARPOL Annex II, Regulation 6*.
- .4 Approved *P&A Manual* and *SMPEP* shall be kept onboard.
- .5 Any cargo operation related to noxious liquid substances shall be entered into the Cargo Record Book.

3.2.2 Basic Technical Documentation

- .6 *Certificate or Statement of Compliance.*
- .7 Procedures and Arrangements Manual (P&A Manual).
- .8 Shipboard marine pollution emergency plan for Noxious Liquid Substances (SMPEP).

3.3 Prevention of Sea Pollution by Harmful Substances Carried by Sea in Packaged Form (MARPOL Annex III)

3.3.1 Basic Requirements

To maintain a *Certificate of Fitness for the Carriage of Dangerous Goods* (or a *Document of Compliance* in cases where Annex III to the *MARPOL Convention* is not applicable), survey shall be conducted in accordance with Surveys for the Certificate of Fitness for the Carriage of Dangerous Goods, Chapter 15 of *Rules for Statutory Survey of Sea-Going Ships, Part I* and a special attention shall be paid on the following:

- .1 Each ship carrying harmful substances shall meet the requirements of the *IMDG Code*.

3.3.2 Basic Technical Documentation

- .1 Cargo manifest or stowage plan indicating, in accordance with the relevant provisions of the *IMDG Code*, the harmful substances on board and their location thereof.

3.4 Prevention of Sea Pollution by Sewage (MARPOL Annex IV)

3.4.1 Basic Requirements

To maintain an *International Sewage Pollution Prevention Certificate* (or a *Statement of Compliance* in cases where Annex IV to the *MARPOL Convention* is not applicable), survey shall be conducted in accordance with Surveys for the International Sewage Pollution Prevention Certificate, Chapter 10 of Supplement to the *Rules for the Statutory Survey of Sea-Going Ships, Part I* and a special attention shall be paid to the following:

- .1 Equipment for the prevention of pollution by sewage shall be installed as prescribed in Regulation 9, Annex IV to the *MARPOL Convention*.
- .2 Disinfectant feed locations of sewage systems shall be easily accessible. Sampling locations shall also be easily accessible. Sampling devices may be portable.
- .3 Vent piping from sewage systems shall be independent of other ventilation systems.
- .4 Sewage treatment plant and sewage holding tank shall be provided with a pipeline and the relevant shore connection flange for discharging sewage to port sewage treatment facility.

3.4.2 Basic Technical Documentation

- .1 *International Sewage Pollution Prevention Certificate.*
- .2 If a sewage treatment plant is installed, then also certificate issued by the Administration or recognized organization certifying that the plant complies with the *Resolution MEPC.227(64) as amended by MEPC.284(70)*.
- .3 Sewage piping system drawing.
- .4 Calculation of rate of discharge of untreated sewage from ship.

3.4.3 Additional Requirements

- .1 Greywater (water discharged from bathrooms and showers etc.) shall be discharged using the sewage treatment plant.
- .2 Re-used or recycled greywater shall satisfy the on-shore drinking water standards of the flag state or port state.
Water quality shall be confirmed based on the test standards specified in the directives of the relevant Ministry.

- .3 To ensure sewage treatment and discharge according to Regulation 11 of Annex IV to the *MARPOL Convention*, procedures related to sewage treatment shall be established and implemented. These procedures have to include the following items:
 - .1 In cases where maintenance, repairs, modifications and disinfectant feeds have been performed, records for the same shall be prepared and maintained.
 - .2 The date, location and quantity of discharged sewage from storage tanks to reception facilities.
 - .3 Records of discharge locations and ship operating speeds in cases where discharge equipment (sewage comminuting and disinfecting systems) according to 1.2 of Regulation 9, Annex IV to the *MARPOL Convention*, has been provided.

3.4.4 Additional Technical Documentation

- .1 Water quality and shore drinking water standard details in cases where greywater is re-utilized.
- .2 Drawings of greywater re-utilization system.
- .3 If a new sewage treatment plant is installed then certificate issued by the Administration or recognized organization certifying that the plant complies with *Resolution MEPC.227(64)* as amended by *MEPC.284(70)*.

3.5 Prevention of Sea Pollution by Garbage (MARPOL Annex V)

3.5.1 Basic Requirements

To maintain *Garbage pollution prevention certificate of compliance* (or a *Statement of Compliance* in cases where Annex V to the *MARPOL Convention* is not applicable) survey shall be conducted in accordance with Surveys for the garbage pollution prevention certificate of compliance, Chapter 11 of the Supplement to the *Rules for Statutory Survey of Sea-going Ships*, Part I and a special attention shall be paid to the following

- .1 Garbage management plans shall be prepared and effectively implemented.
Such plans shall provide procedures for collecting, storing, processing and disposing of garbage (including the use of shipboard equipment) in accordance with the provisions of 2, Regulation 10, Annex V to the *MARPOL Convention*.
- .2 A form of the *Garbage Record Book* of Annex V to the *MARPOL Convention* shall be provided. The following items shall be entered into the *Garbage Record Book*:
 - .1 Each discharge operation, or completed incineration, shall be recorded in the Book and signed for on the date of the incineration or discharge by the officer in charge.
 - .2 The entry for each incineration or discharge shall include the date and time, position of the ship, description of the garbage and the estimated amount incinerated or discharged.
 - .3 In the event of any discharge, escape or accidental loss, an entry shall be made in the Book describing the circumstances of, and the reasons for, such loss.
- .3 In cases where onboard incinerators are installed, then said incinerators shall satisfy the requirements given in Regulations 16.7 and 16.9, Annex VI to the *MARPOL Convention*. The incinerator shall be of type approved one by the Administration or a Recognized Organization.

3.5.2 Basic Technical Documentation

- .1 *Garbage Management Plan*.
- .2 Procedure related to onboard incineration if an onboard incinerator is provided.

3.5.3 Additional Requirements

- .1 All garbage generated onboard a ship shall be transferred to shore reception facilities.
- .2 The records of such garbage shall be maintained in the *Garbage Record Book*.

4 ECO AIR

To maintain an *International Air Pollution Prevention Certificate* (or a *Statement of Compliance* in cases where Annex VI to the *MARPOL Convention* is not applicable), survey shall be conducted in accordance with Surveys for the International Air Pollution Prevention Certificate, chapter 12.1 of the *Rules for Statutory Survey of Sea-Going Ships, Part I* and a special attention shall be paid to the following:

4.1 Nitrogen Oxides (NO_x)

4.1.1 Basic Requirements

- .1 Applicable to those diesel engines specified in Regulations 13.1, and 13.2, Annex VI to the *MARPOL Convention*.
- .2 Diesel engines conforming to Regulations 13.1 and 13.2 shall satisfy the requirements given in Regulations 13.3 to 13.5, Annex VI to the *MARPOL Convention*.
- .3 Ships shall possess either an *Engine International Air Pollution Prevention (EIAPP) Certificate* (or a *Statement of Compliance* in cases where Regulation 13, Annex VI to the *MARPOL Convention* is not applicable) issued by the Administration or Recognized Organization, as certification.
- .4 Diesel engines conforming to Regulations 13.1 and 13.2 shall be provided with a Technical File and *Record Book of Engine Parameters* satisfying the requirements *NO_x Code*.
- .5 In cases where NO_x reduction systems are provided, the items below shall be satisfied for such systems in addition to the provisions of items 2-4 above.
 - .1 Even if NO_x reduction systems fail, engines shall operate safely and continuously without any hindrance.
 - .2 Systems shall be operated in accordance with manufacturer instructions, if any.
 - .3 Systems shall be designed, manufactured and fitted such that structural integrity and isolation from large vibrations are ensured.
 - .4 Adequate size hatches shall be provided for inspections and maintenance.
 - .5 Devices for recording operation status shall be provided. The device operation and control levels shall be recorded, and such records shall be stored.

4.1.2 Basic Technical Documentation

- .1 An Engine International Air Pollution Prevention (EIAPP) Certificate or a MARPOL Annex VI Statement of Compliance of requirements related to NO_x emissions.
- .2 Technical file indicating engine model, rated output, application and NO_x emission value.
- .3 If NO_x post-treatment system is installed, details of this system and Technical File and on board NO_x verification procedures.

4.1.3 Additional Requirements

- .1 The NO_x total emission value, NO_{xtotal} (equation 1) of emissions from all diesel engines (excluding special engines for emergency use) of output 130kW and greater installed on the ship shall not exceed 80% of the NO_x emission limit NO_{xlimit} (equation 2) for the ship.

$$NO_{xtotal} = \sum_{i=1}^N (NO_{xCert,i} \cdot P_i) \quad (\text{g/h}) \quad (1)$$

$$NO_{xlimit} = \sum_{i=1}^N (NO_{xIMO,i} \cdot P_i) \quad (\text{g/h}) \quad (2)$$

where:

N – number of all diesel engines (excluding special engines for emergency use) of output 130kW and greater installed on the ship,

P_i – rated output of each diesel engine (kW),

$NO_{xCert,i}$ – weighted NO_x emission value from each approved diesel engine (g/kWh),

$NO_{xIMO,i}$ – NO_x emission limit for each diesel engine (according to Regulations 13.3 to 13.5, *MARPOL Annex VI*) (g/kWh).

- .2 If each of the engines is in a family engine or a group engine in accordance with the *NO_x Technical Code*, the emission value may be taken as the emission value of the parent engine.
- .3 Regardless of item 2, if measurements are performed on an actual ship, the method of performing such measurements shall be in accordance with the onboard simplified measurement method and the onboard monitoring method in the provisions of Regulation 2.15, Annex VI to the *MARPOL Convention*.

4.1.4 Additional Technical Documentation

- .1 Statements certifying that the NO_x total emission value does not exceed 80% of the regulated NO_x emission value for the relevant ship.

4.2 Sulphur Oxides (SO_x)

4.2.1 Basic Requirements

- .1 The sulphur content of the fuel oil used in ships shall not exceed values specified in Regulation 14.1 and 14.4 Annex VI to the *MARPOL Convention*.
- .2 Alternatively, ships shall be provided with systems or methods which are as effective as those required by Regulation 4, Annex VI to the *MARPOL Convention* and approved by the Administration or recognized organization for compliance with requirements given in *Resolution MEPC.259(68)*.
- .3 Ships entered in SO_x emission control area shall reduced sulphur content in bunkered fuel used on ship.
- .4 A Bunker Delivery Note specified in the provisions of Regulation 18, Annex VI to the *MARPOL Convention* shall be provided on ships. Those samples specified in such provisions shall be attached to the Bunker Delivery Note. The sample taking method and the storage method shall be in accordance with the requirements given in *Resolution MEPC.182(59)*.
The storage period for Bunker Delivery Notes shall be taken as 3 years minimum and for samples as 1 year minimum.

4.2.2 Basic Technical Documentation

- .1 Procedure containing control of sulphur content of fuel oil at the time of fuel bunkering.

4.2.3 Additional Requirements

- .1 The sulphur content of all fuel oils shall not exceed 0.1%.
- .2 Installation of exhaust gas cleaning system for reduction SO_x.
- .3 Fuel bunker sampler shall be provided.

4.2.4 Additional Technical Documentation

- .1 If exhaust gas cleaning system to reduce SO_x is installed, details of said system.
- .2 *SECA Compliance Plan*.
- .3 SCC SECA Compliance Certificate.
- .4 EGC – SO_x Technical Manual for Scheme A.
- .5 EGC – SO_x Technical Manual for Scheme B.
- .6 OMM Onboard Monitoring Manual.
- .7 A record of the EGC unit in-service operating parameters, component adjustments, maintenance and service records as appropriate.

4.3 Ozone Depleting Substances

The provisions given below apply to all refrigerating machinery, refrigerating facilities, air-conditioning equipment and fire extinguishing facilities which contain the ozone depleting substances provided on ships. However, they are not applicable to permanently sealed equipment where there are no refrigerant charging connections or potentially removable components containing ozone depleting substances (e.g. independent refrigerators and air conditioning units provided for domestic use).

4.3.1 Basic Requirements

- .1 Refrigerating machinery, refrigerating facilities and air-conditioning equipment shall not use ozone depleting substances, excluding hydrochlorofluorocarbons (HCFCs), as refrigerants. After 1 January 2020, HCFCs cannot be used as a refrigerant in newly installed equipment.
- .2 In order to prevent refrigerant leaks, appropriate locations in refrigerant facilities such as locations where leaks are likely to occur and refrigerant maintenance locations shall be monitored.
- .3 Compressors for refrigerants shall be designed to discharge any refrigerant contained within to receivers during maintenance.
- .4 Procedures with methods to be implemented for controlling loss, leakage, discharge and disposal of refrigerants shall be prepared and implemented. These procedures shall contain at least the following items:
 - .1 Measures to be adopted in cases where leaks have been confirmed by leak detectors.
 - .2 Appropriate shut-off methods to prevent the emission of refrigerants into the atmosphere during maintenance, overhauling or repair work.
 - .3 During the recovery of refrigerants, recovery equipment shall be provided in order to discharge refrigerants into existing receivers or special cylinders, which have enough capacity to store the entire amount of refrigerant between shut-off points.
- .5 A list and a record book of equipment containing ozone depleting substances shall be maintained onboard ship and the following items shall be recorded during the filling and disposing of refrigerants as well as during repairs and modifications to refrigerating installations:
 - .1 Refrigerant added to each system.
 - .2 Leakage of refrigerant including corrective actions.
 - .3 Recovered refrigerant and its storage.
 - .4 Disposed-off refrigerants.
- .6 Fixed and portable fire extinguishing systems shall not include halons.
- .7 Annual refrigerant leakage shall be as small as possible but not more than 10% of the total refrigerant charge for each system. The leakage shall be documented through recorded consumption figures. The figures shall include topping up due to leakage, as well as renewal of refrigerant during repairs or overhauls. The refrigerant log shall at least include: date, system type, refrigerant type, type of failure, initial system charge, refrigerant added, refrigerant recovered, signature type of inspection performed and corrective actions.

If leakage is observed, corrective measures as detailed in the refrigerant management procedure shall be implemented.
- .8 The use of ozone depleting substances is not permitted. The refrigerant may be any of the following:
 - HFC
 - Natural refrigerants such as NH₃ or CO₂.

The used refrigerant shall have Global warming potential (GWP) not greater than 3500 (GWP < 3500).

4.3.2 Basic Technical Documentation

- .9 Arrangement of refrigerating systems.
- .10 Capacity of refrigerating systems.
- .11 Details of refrigerants used.
- .12 Details of the fire fighting medium used in fixed type and portable fire extinguishing systems.

4.3.3 Additional Technical Documentation

- .1 Procedure containing the work to be performed for controlling the loss, leakage, discharge and disposal of refrigerants.
- .2 A *Refrigerant Systems Management Plan* shall be placed onboard for the guidance of the operating personnel.

This plan shall give clear guidance to the crew about the refrigerant systems and shall include, as a minimum:

- .1 Vessel name and PRS number.
- .2 Simplified diagrams and component description of all refrigerant systems.
- .3 Procedures detailing the means to control the loss, leakage, venting, and disposal of refrigerants.
- .4 Methods and means of recording in mass (kilograms) refrigerant inventory. The recorded data shall include, as a minimum, the following:
 - Supply of refrigerant onboard
 - Discharge of refrigerant to the atmosphere due to leaks or system maintenance.
 - Recovered refrigerant including its storage location.
 - Refrigerant disposal to land-based reception facilities.

The Refrigerant Systems Management Plan shall be submitted for review to verify the presence of the above information, which shall be consistent with the design information and limitations considered.

4.4 Volatile Organic Compounds (VOCs)

4.4.1 Basic Requirements

- .1 A VOC emission control system complying with *MSC/Circ.585* or *USCG 46CFR39* shall be provided, and shall be approved and certified by the Society or a Recognized Organization.

4.4.2 Basic Technical Documentation

- .1 *VOC Management Plan* (crude oil tankers only).

4.4.3 Additional Technical Documentation

In ships carrying crude oil, petroleum products or chemicals with flash points not exceeding 60 °C, either one of items below shall be complied with.

- .1 The construction shall be such that vapours of volatile organic compounds generated in cargo tanks are not discharged outside the ship by the re-liquefaction process.
- .2 A *Transfer procedure manual* for the equipment in items above shall be provided.

4.4.4 Additional Technical Documentation

- .1 Certificate from the Administration or representative organization indicating that the VOC emission control system, if provided, complies with the *MSC/Circ.585 (MARPOL, Annex VI, Certificate Supplement)*.
- .2 Details of the re-liquefaction system, if provided.
- .3 System operating procedures to prevent the emission of VOC or re-liquefaction system.

4.5 Ships Energy Efficiency

4.5.1 Basic Requirements

To maintain an *International Energy Efficiency Certificate* (or a *Statement of Compliance* in cases where Annex VI to the *MARPOL Convention* is not applicable), survey shall be conducted in accordance with Surveys for the *International Energy Efficiency Certificate*, Chapter 12.2 of Supplement to the *Rules for Statutory Survey of Sea-Going Ships, Part I*.

The ship shall meet the provisions of energy efficiency given in Regulation 20, 21 and 22, Annex VI, *MARPOL Convention* and in *PRS' Publication No. 103/P – Guidelines of Energy Efficiency of Ships*.

4.5.2 Basic Technical Documentation

- .1 Technical file of EEDI (Energy Efficiency Design Index) for new ships,
- .2 *Ship Energy Efficiency Management Plan (SEEMP)* for new and existing ships.

4.6 Incineration Equipment

4.6.1 Basic Requirements

- .1 Each incinerator with a capacity of up to 4,000 KW on a ship constructed on or after 1 January 2000 or incinerator with a capacity of up to 4,000 KW which is installed on board a ship on or after 1 January 2000, shall fulfil the requirements specified in Appendix IV to Annex VI to the *MARPOL Convention*. Each incinerator subject to this paragraph shall be approved by the Administration taking into account the standard specification for shipboard incinerators specified in *IMO MEPC.76(40)* or *MEPC.244(66) resolution*.
- .2 For incinerators installed in accordance with the requirements specified in paragraph 4.6.1.1, the combustion chamber gas outlet temperature shall be monitored at all times the unit is in operation. Where that incinerator is of the continuous-feed type, waste shall not be fed into the unit when the combustion chamber gas outlet temperature is below 850 °C. Where that incinerator is of the batch-loaded type, the unit shall be designed so that the combustion chamber gas outlet temperature reaches 600 °C within five minutes after the start-up and will thereafter stabilize at a temperature not less than 850 °C.
- .3 Shipboard incineration of the following substances is prohibited:
 - (a) residues of cargoes subject to Annex I, Annex II or Annex III to the *MARPOL Convention* or related contaminated packing materials;
 - (b) polychlorinated biphenyls (PCBs);
 - (c) garbage, as defined in Annex V, containing more than traces of heavy metals;
 - (d) refined petroleum products containing halogen compounds;
 - (e) sewage sludge and sludge oil either of which are not generated onboard the ship; and
 - (f) residues originated from exhaust gases cleaning systems.
- .4 Shipboard incineration of polyvinyl chlorides (PVCs) shall be prohibited, except in shipboard incinerator which fulfils the requirements specified in paragraph 4.6.1.1.

4.6.2 Basic Technical Documentation.

- .1 *Type Approval Certificate* from the Administration or recognized organization indicating that incinerating equipment complies with Regulation 16, *MARPOL*, Annex VI;
- .2 A complete instruction and maintenance manual with drawings, electric diagrams, spare parts list, etc;
- .3 Procedures for the operations of incineration onboard.

4.7 Electrical Shore Power Supply Systems

4.7.1 Basic Requirements

A high voltage shore power connection system which is capable of supplying sufficient electrical power to the ship shall be provided. (High voltage means 1kV or more.)

4.7.1.1 Stand-by Power

- .1 While the electric shore connection is supplying power to the vessel, at least one of the vessel's generators shall be in standby. Namely, this generator shall be automatically started and connected to the main switchboards in case of blackout (loss of power supply from shore);
- .2 In order to transfer power between the vessel's supply and shore, means for synchronization shall be arranged in the vessel's main switchboard.

4.7.1.2 Voltage and Frequency

- .1 When a vessel is powered by shore power supply, the system voltage and frequency of the shore utility supply must match the system voltage and frequency of the vessel.

4.7.1.3 System Earthing and Protective Earthing

- .1 The vessel's designed system earthing shall be maintained in electrical shore connection operation. The selected design solution must be described in the documentation of the system.
- .2 A separate conductor for protective earthing shall be connected between the hull of the vessel and the ground on the shore. Earth fault protection shall disconnect the shore power supply, both the shore side circuit breaker and the vessel's main switchboard circuit breaker, whenever an earth fault current flows in the protective earthing conductor of the shore power cable.
- .3 Conductors used for system earthing or protective earthing shall be dimensioned so that they can carry the current that will flow in a worst case failure scenario.
- .4 There shall be a monitoring system ensuring proper connection between shore ground and hull.

4.7.1.4 Galvanic Isolation

- .1 For high voltage electrical shore connections, the shore side distribution system and the vessel's distribution system shall be galvanically separated. When this separation is performed by a transformer, this shall have separate windings for the primary and the secondary side. The transformer can be installed either on shore, or on board.
- .2 If a power transformer is installed on board for adaptation of the electric shore connection system voltage and the main switchboard voltage, the transformer shall include overvoltage protection, protecting the vessel against lightning impulse over voltages.
- .3 It is recommended that the same safeguards against overvoltage are applied when the transformer is installed on shore.

4.7.1.5 Short Circuit Strength

- .1 All circuit breakers and cables used for the electrical shore connection shall be rated for the prospective short circuit currents that may appear at their location in the installation. Interlocks shall be provided in switchboards against simultaneously feeding from the ship's own generators and the electrical shore connection when the parallel connected short circuit power exceeds the switchboards' short circuit strength. A short time parallel feeding as a "make before break" arrangement is accepted when arranged with automatic disconnection of one of the parallel feeders within 30 s.
- .2 The electrical shore connection system may only be used when the short circuit power from shore supply network gives prospective short circuit currents that are less than the rated short circuit making and breaking capacities for switchgear installed in the ship's distribution system.

4.7.1.6 Selectivity / Discriminative Disconnection

- .1 The short circuit protection of equipment and cables between the shore-side supply circuit breaker and the main switchboard's shore power incoming circuit breaker shall be performed by short circuit protection on both sides of the electrical shore connection. (Short circuit protection in both shore side supply and the main switchboard incoming circuit breaker.)
- .2 These rules do not require that the vessel's distribution system has full discrimination during electrical shore power supply. Limitations in the selectivity shall be described in the system philosophy.

4.7.1.7 Switchgear and Interlocks

4.7.1.7.1 Flexible Shore to Ship Connection

- .1 The equipment enabling efficient cable handling and connection shall be installed.
- .2 The shore connection cable shall be connected by plug and socket connection. Plugs and sockets shall be designed in such a way that incorrect connection is not possible.
- .3 Connection or opening of the plug and socket with power on shall not be possible.
- .4 The plug and socket system shall be of a type tested design, suitable for marine use.

- .5 The plug and socket system shall include a pilot contact for verification of correct connection of the plug and socket. This pilot contact shall be used for interlocks in the circuit breaker control.
- .6 The flexible cable shall be terminated close to the ship's side, and not be used as a part of the fixed cable installation in the vessel. A separate ship-side circuit breaker is not required where the flexible cable is terminated.

4.7.1.7.2 Cable Management System

- .1 A cable management system shall be installed, which ensures that the mechanical tension in the shore to ship cable is maintained within the design parameters of the cable. The cable shall never become so slack that it may be chafed, nor stretched beyond its design limits. The cable management system shall give alarm at high cable tension to a manned position. At high high tension, the shore connection shall be automatically disconnected, and the earthing switches closed. Automatic release of the plug and socket connection is not required.

4.7.1.7.3 Switchgear

- .1 Electrical shore connection systems shall be equipped with circuit breakers suitable for isolation and interruption of possible short circuit currents.
- .2 The circuit breakers shall be equipped with under-voltage, overcurrent and short circuit trip functions.
- .3 High voltage electrical shore connection systems shall be equipped with automatically operated earthing switches at both sides of the cable connecting the shore to vessel enabling safe discharge of the cable and safe handling of the plug and socket.
- .4 The earthing switches shall not be possible to open before healthy connection of plug and socket is confirmed, and automatically close if the healthy signal is lost. The automatic closing may be delayed in order to allow opening of the circuit breakers before closing.
- .5 Closing of the circuit breakers shall not be possible unless the earthing switches are confirmed open.

4.7.1.7.4 Interlocks

- .1 Circuit breakers that are part of the electrical shore connection system, inclusive on board circuit breakers for generators, earthing switches and others, shall have necessary interlocks preventing any hazardous switching operations. These interlocks shall be described in the documentation.
- .2 The incoming shore power circuit breaker in the main switchboard shall be interlocked against closing unless a check synchronising relay accepts closure, or all generator circuit breakers in the main switchboard is in open position.
- .3 The incoming shore power circuit breaker in the main switchboard and the shore side supply circuit breaker shall be provided with the following interlocks:
 - a) Automatic opening of both shore-side and ship-side circuit breakers and, for high voltage systems, closing of earthing switches:
 - upon high high mechanical tension of shore connection cable,
 - by missing confirmation of healthy protective earthing connection,
 - by missing pilot contact confirmation that the plug and socket is properly connected,
 - by emergency disconnection signal,
 - short circuit and overcurrent detection on either side of the shore connection cable,
 - earth failure detection. (May be selective towards disconnection of earth failures in the on-board distribution system.)
 - under-voltage detection on either side of the electrical shore connection.
 - b) Operation of the plug and socket:
 - when the plug and socket is manually operated, an attempt to open the plug shall automatically initiate opening of the circuit breakers in both ends of the connection. For high voltage connections, the earthing switches shall be closed.
- .4 There shall be an interlock preventing closing of shore circuit breaker unless plug and socket is correctly connected and eventual earthing switches on both shore-side and ship-side are opened.

- .5 An attempt to insert or withdraw the plug shall initiate opening of circuit breakers and closing of earthing switches. For automatically operated plug and socket, the same feature shall be implemented in the control system.
- .6 Closure of circuit breakers shall not be possible if proper protective earthing connection is not confirmed. If proper earthing connection is lost, the breakers shall open.
- .7 Activation of protective functions (including high cable tension and emergency disconnection) shall give an alarm to a continuously manned location.

4.7.1.8 Emergency Disconnection

4.7.1.8.1 General

- .1 An independent system for emergency disconnection shall be arranged with emergency stop push buttons.
- .2 There shall be one emergency stop button in each of the following locations:
 - at the ship's side where the electrical shore connection is located,
 - where the cable management system is handled,
 - at the shore connection switchboard, and at a continuously manned location.
- .3 Activation of emergency stop shall result in disconnection of circuit breakers and closing of earthing switches.
- .4 Opening, or release, of the plug and socket may be a manual operation.

4.7.1.9 Control and Monitoring

4.7.1.9.1 General

- .1 A control system shall be arranged on-board the vessel for the electric shore connection system.
- .2 This system shall trip both shore side circuit breaker and main switchboard incoming circuit breaker in case of:
 - earth fault,
 - short circuit / overcurrent,
 - shore side under voltage,
 - cable break,
 - failure of protecting earthing connection.
- .3 The control system shall prevent the shore side circuit breaker to close until the ship's operator manually gives permission. This permission shall not be possible to send unless correct protective earthing, plug/socket connection, and open on-board earthing switch is verified.
- .4 On the ship side of the electric shore connection systems, at the control position for the shore power incoming circuit breaker, the following instrumentation shall be installed:
 - phase sequence indicator
 - frequency meters for ship and shore power
 - voltmeter
 - ampere meter in each phase or fitted with ampere meter switch
 - energy measurement (kWh counter)
 - synchronisation equipment.
- .5 At all locations from where the electrical shore connection or cable management system may be controlled, the following alarms and controls shall be available:
 - high and high high tension of the flexible cable,
 - loss of shore power,
 - emergency disconnection,
 - activation of protective functions as earth fault, overcurrent and short circuit.

4.7.1.10 Installation

4.7.1.10.1 General

- .1 The on board electrical installations for the electrical shore connection system shall fulfil the installation requirements given in *PRS Rules, Part VIII*.
- .2 All high voltage equipment shall be marked with high voltage warning sign.
- .3 A flexible shore connection cable can be arranged either on board the vessel or situated at key. In both situations a cable handling system must be arranged.
- .4 Cables of networks operating above 1000V shall be separated from the cables of networks operating below 1000V and they shall be clearly marked.
- .5 All cables installed on board shall be with PRS type approval certificate or with PRS product certificate.

4.7.1.11 Survey and Testing

4.7.1.11.1 Survey and Testing Requirements

- .1 Before an electrical shore connection installation is put into service or considered ready for operation, it shall be inspected and tested. The aim for this testing shall verify that the physical installation is correct. The installation shall be verified in accordance with relevant documentation.
There shall be no hazard to personnel, no inherent fire hazard, and the installation shall function as required for the safe operation of the vessel. This also applies after modifications and alterations.
- .2 It shall be verified that all equipment is suitably installed with respect to ventilation, ingress protection and accessibility.
- .3 All equipment shall be verified with respect to proper installation with respect to external wiring and protective earthing, for compliance with relevant documentation.
- .4 After installation, with termination kit applied, high voltage cables shall be subject to high voltage tests as described in PRS Rules Pt. VIII p.18.10.
- .5 After high-voltage test, all power circuits (cables and consumers) connected during installation shall undergo insulation resistance testing to verify its insulation level towards earth and between phases. The insulation resistance shall be at least 2000 Ω/V of nominal voltage, according to *PRS Rules, Part VIII*, p. 18.1.2.
- .6 Function tests shall be performed in order to evaluate that the installation fulfils the requirements of these rules. The function testing shall verify that required interlocks are working properly, and shall cover both the ship-side installation and the shore-side installation.

4.7.2 Basic Technical Documentation

4.7.2.1 Documentation Requirements

- .1 The documentation listed below shall be submitted to PRS Head Office for approval:
 - overall single line diagram, including system earthing for the electric shore connection,
 - single line diagrams/consumer list for switchboards. Electrical documentation of switchboards and switchgear installed as part of the electrical shore connection system and the cubicle in the main switchboard associated with the electrical shore connection. (Including switchboard layout and arrangement drawings, and schematics with information on protection, synchronisation, breaker interlocks, undervoltage trips, remote control circuits as relevant.),
 - electrical consumption balance, design values for power consumption and available power for operational modes utilising the electrical shore connection,
 - control system, functional description including description of instrumentation, interlocks, monitoring and alarms,
 - test procedure for quay and sea trial.
- .2 The below documentation shall be submitted to PRS Head Office for information:
 - the overall description of the electrical shore connection system and operating philosophy for all relevant operating modes,
 - short circuit calculations, the design values for the maximum and minimum short circuit power from the shore side shall be described,

- the selectivity on board the vessel while fed from the electric shore connection shall be described,
 - voltage tolerances, waveform and harmonic content in the supply voltage, when the electrical shore connection is powered by a frequency converter,
 - the operational manual intended for regular use on board, providing information on: operation modes, operating instructions, procedures, and details of the user interface.
- .3 Additional documentation may be required, depending on the chosen technical solution.

5 ECO EF

5.1 Basic Requirements

To maintain an *International Energy Efficiency Certificate* (or a *Statement of Compliance* in cases where Annex VI to the *MARPOL Convention* is not applicable), survey shall be conducted in accordance with Surveys for the International Energy Efficiency Certificate, Supplement to *Rules for Statutory Survey of Sea-going Ships*, Part I, Chapter 12.2.

The ship shall meet the provisions of energy efficiency specified in Regulations 20, 21 and 22, Annex VI, *MARPOL Convention* and in *PRS Publication No. 103/P – Guidelines of Energy Efficiency of Ships*.

5.2 Basic Technical Documentation

- .1 Technical file of EEDI (*Energy Efficiency Design Index*) for new ships,
- .2 *Ship Energy Efficiency Management Plan (SEEMP)* for new and existing ships.

5.3 Additional Requirements

- .1 Ships' attained energy efficiency design index shall be smaller than the required EEDI (calculated for that specific period of time),
- .2 The ship shall meet the provisions of energy efficiency given in *PRS Rules for the Classification and Construction of Sea-Going Ships*:
 - *Part II – Hull*,
 - *Part VI – Machinery Installations and Refrigerating Plants*,
 - *Part VII – Machinery, Boilers and Pressure Vessels*,
 - *Part VIII – Electrical Installations and Control Systems*.

5.4 Additional Technical Documentation

The scope of documentation at each stage and the requirements are described in *Guidelines on Survey and Certification of the Energy Efficiency Design Index (EEDI)* and in *First Industry Guidelines for Calculation and Verification of the Energy Efficiency Design Index (EEDI)*, both contained in *Publication 103/P*.

6 ECO BWM

Definitions

Ballast Water Management System (BWMS) – any system which processes ballast water such that it meets or exceeds the Ballast Water Performance Standard in Regulation D-2 of the BWM Convention. The BWMS includes ballast water management equipment, all associated control equipment, monitoring equipment and sampling facilities.

Dangerous gas – any gas which may develop an explosive and/or toxic atmosphere being hazardous to the crew and/or the ship, e.g. hydrogen (H₂), hydrocarbon gas, ozone (O₃), chlorine (Cl) and chlorine dioxide (ClO₂), etc.

Hazardous area – area in which an explosive gas atmosphere is or may be expected to be present, in quantities such as to require special precautions for the construction, installation and use of equipment. When a gas atmosphere is present, the following hazards may also be present: toxicity, asphyxiation, corrosivity and reactivity.

Dangerous liquid – any liquid that is identified as hazardous in the Material Safety Data Sheet or other documentation relating to this liquid.

6.1 Basic Requirements

To conform to the *International Convention for the Control and Management of Ships' Ballast Water and Sediments*, survey shall be conducted in accordance with *BWM.2/Circ.7* and a special attention shall be paid on the following:

- .1 *Ballast Water Management Plan (BWMP)* shall be prepared according to *International Convention for the Control and Management of Ships' Ballast Water and Sediments* which required discharge or treatment of ballast water depending on year of building or total volume of ballast water on ship.
- .2 *Ballast Water Record Book* shall be maintained and managed onboard ship.
- .3 **Ballast water management system installed:**
 - on board ships prior to 28 October 2020 shall comply with *IMO Resolution MEPC.174(58) (G8)* or preferably with *IMO Resolution MEPC.279(70)*;
 - on ships on or after 28 October 2020 shall comply with *IMO Resolution MEPC.279(70) (G8)*. *Type-approval Certificate* issued by the Administration or recognized organization for the ballast water management system shall be provided.
- .4 In addition to the item above, certificates issued by the IMO to certify the compliance with *IMO Resolution MEPC.169(57)* for ballast water **management** systems using active substances shall be available.

6.2 Basic Technical Documentation

- .1 *Ballast Water Management Plan* shall be approved by the Society or other recognized organization.
- .2 In cases where a ballast water **management** system is installed, a certificate from the Administration or recognized organization certifying that such equipment complies with Regulation D-2 of the *International Convention for the Control and Management of Ship Ballast Water and Sediments*, and a certificate certifying that final approval of the IMO has been received when the said system uses active substances.
- .3 *Ballast water treatment system manual* describing details of such system (including types of active substances used), if installed.

6.3 Additional Technical Documentation

- .1 Biofouling Management Plan according to *MEPC.207(62)*.
- .2 *Biofouling Record Book* according to *MEPC.207(62)*.

6.4 Installation

6.4.1 General Requirements

6.4.1.1 All valves, piping fittings and flanges shall fulfil the relevant requirements of UR P2 and P4. In addition, special consideration can be given to the material used for this service with the agreement of PRS.

6.4.1.2 The BWMS shall be provided with by-pass or override arrangement to effectively isolate it from any essential ship system to which it is connected.

6.4.1.3 The BWMS shall be operated at a flow rate within the Treatment Rated Capacity (TRC) range specified in the Type Approval Certificate (TAC).

6.4.1.4 Where a vacuum may occur in the ballast line due to the height difference, a suitable protection means shall be provided, e.g. P/V valves or breather valves, and their outlets shall be led to safe area on open deck.

6.4.1.5 Electric and electronic components shall not be installed in a hazardous area unless they are of certified safe type for use in the area. Cable penetrations of decks and bulkheads shall be sealed when a pressure difference between the areas shall be maintained.

6.4.1.6 Where the operating principle of the BWMS involves the generation of a dangerous gas, the following requirements shall be satisfied:

- .1 Gas detection equipment shall be fitted in the spaces where dangerous gas could be present, and an audible and visual alarm shall be activated both locally and at the BWMS control station in the event of leakage. The gas detection device shall be designed and tested in accordance with IEC 60079-29-1 or recognized standards acceptable by PRS.
- .2 The ventilation line of a space where dangerous gas could be present shall be led to a safe area on open deck.
- .3 The arrangements used for gas relieving, i.e. degas equipment or equivalent, shall be provided with monitoring measures with independent shutdown. The open end of the gas relieving device shall be led to a safe area on open deck.

6.4.1.7 Ballast piping, including sampling lines from ballast tanks considered as hazardous areas, shall not be led to an enclosed space regarded as a safe area, without any appropriate measures, except ships carrying liquefied gases in bulk. However, a sampling point for checking the performance of BWMS, for ballast water containing dangerous gas, may be located in a safe area provided the following requirements are fulfilled:

- .1 The sampling facility (for BWMS monitoring/control) shall be located within a gas tight enclosure (hereinafter, referred to as a 'cabinet'), and the following (i) through (iii) shall be fulfilled.
 - i) In the cabinet, a stop valve shall be installed in each sample pipe.
 - ii) Gas detection equipment shall be installed in the cabinet and the valves specified in i) above shall be automatically closed upon activation of the gas detection equipment.
 - iii) Audible and visual alarm signals shall be activated both locally and at the BWMS control station when the concentration of explosive gases reaches a pre-set value, which shall not be higher than 30% of the lower flammable limit (LFL) of the concerned product.
- .2 Standard internal diameter of sampling pipes shall be the minimum necessary in order to achieve the functional requirements of the sampling system.
- .3 The measuring system shall be installed as close to the bulkhead as possible, and the length of measuring pipe in any safe area shall be as short as possible.
- .4 Stop valves shall be located in the safe area, in both the suction and return pipes close to the bulkhead penetrations. A warning plate stating "Keep valve closed when not performing measurements" shall be posted near the valves. In order to prevent backflow, a water seal or equivalent arrangement shall be installed on the hazardous area side of the return pipe.
- .5 A safety valve shall be installed on the hazardous area side of each sampling pipe.

6.4.1.8 For the spaces, including hazardous areas, where toxicity, asphyxiation, corrosivity or reactivity is present, these hazards shall be taken into account and additional precautions for the ventilation of the spaces and protection of the crew shall be considered.

6.5 Additional Requirements for Tankers

6.5.1 Hazardous area classification shall be in accordance with IEC 60092-502.

6.5.2 In general, two independent BWMS may be required (i.e. one for ballast tanks in hazardous areas and the other for ballast tanks in non-hazardous areas) for tankers carrying flammable liquids having a flashpoint not exceeding 60 °C or products listed in the IBC Code having a flashpoint not exceeding 60 °C or cargoes heated to temperature above their flashpoint and cargoes heated to temperature within 15 °C of their flashpoint.

6.5.3 The interconnection of ballast piping between hazardous areas and in nonhazardous areas may be accepted if an appropriate isolation arrangement is applied. Means of appropriate isolation are as follows:

- .1 Two screw down check valves in series with a spool piece, or

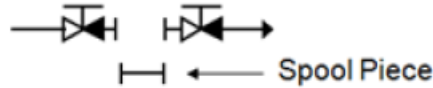

- .2 Two screw down check valves in series with a liquid seal at least 1.5 m in depth, or

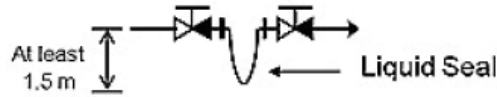

- .3 Automatic double block and bleed valves and a non-return valve

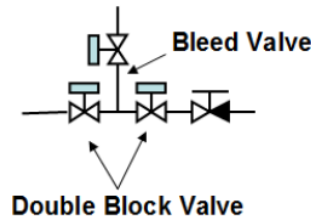

Examples of appropriate isolation means given in red are shown in 6.8. Isolation arrangements shall be fitted on the exposed deck in the hazardous area. Also, ballast water originating from a hazardous area shall not discharge into a non-hazardous area, except as given by 6.4.1.7.

6.6 Ventilation

6.6.1 BWMS not in hazardous areas

- .1 A BWMS that does not generate dangerous gas shall be located in an adequately ventilated area.
- .2 A BWMS that generates dangerous gas shall be located in a space fitted with a mechanical ventilation system providing at least 6 air changes per hour or as specified by the BWMS manufacturer, whichever is greater.

6.6.2 BWMS in Hazardous Areas

A BWMS, regardless of whether or not it generates dangerous gas, shall be located in a space fitted with mechanical ventilation complying with relevant requirements, e.g. IEC60092- 502, IBC Code, IGC Code, etc.

6.7 Special Requirements

6.7.1 The length of pipe and the number of connections shall be minimised in piping systems containing dangerous gases/liquids in high concentration. The following requirements shall also be satisfied:

- .1 Pipe joints shall be of welded type except for connections to shut off valves, double walled pipes or pipes in ducts equipped with mechanical exhaust ventilation. Alternatively it shall be demonstrated that risk of leakage is minimized and the formation of toxic or flammable atmosphere is prevented.
- .2 Location of the piping system shall be away from heat sources and protected from mechanical damage.

6.7.2 For BWMS using chemical substances, handling procedures shall be in accordance with the Material Safety Data Sheet and BWM.2/Circ.20, and the following measures shall be taken as appropriate:

- .1 The materials used for the chemical storage tanks, piping and fittings shall be resistant to such chemicals.
- .2 Chemical storage tanks shall have sufficient strength and be constructed such that maintenance and inspection can be easily performed.
- .3 Chemical storage tank air pipes shall be led to a safe area on open deck.
- .4 An operation manual containing chemical injection procedures, alarm systems, measures in case of emergency, etc, shall be kept onboard.

- 6.7.3** Where the BWMS is installed in an independent compartment, the compartment shall be:
- .1 Provided with fire integrity equivalent to other machinery spaces.
 - .2 Positioned outside of any combustible, corrosive, toxic, or hazardous areas unless otherwise specifically approved.

6.7.4 A risk assessment may be conducted to ensure that risks, including but not limited to those arising from the use of dangerous gas affecting persons on board, the environment, the structural strength or the integrity of the ship are addressed.

6.8 Automation

6.8.1 In case of any by-pass or override operation of BWMS, an audible and visual alarm shall be given and these events shall be automatically recorded in control equipment. The valves in the by-pass line which trigger the by-pass operation shall be remote-controllable by control equipment or fitted with open/close indicator for automatic detection of the by-pass event.

BMWS which does not require after-treatment

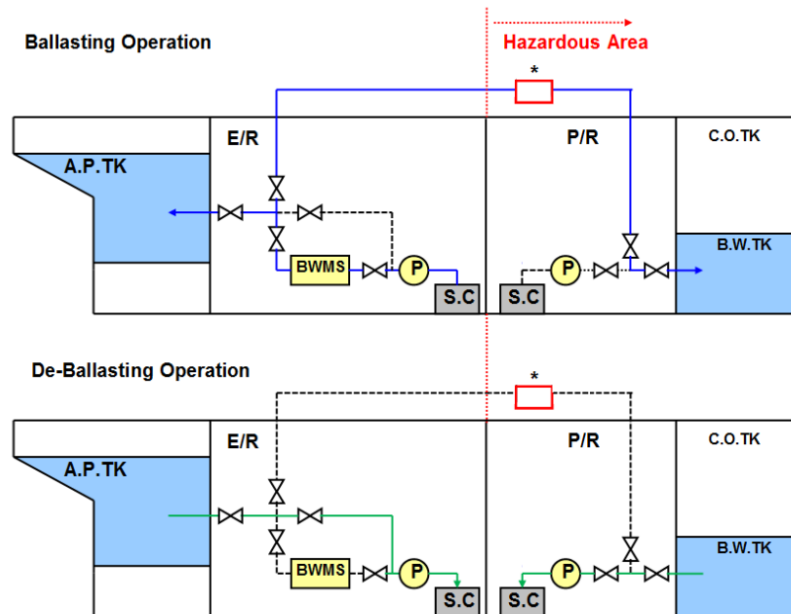

BMWS which requires after-treatment (Injection-type)

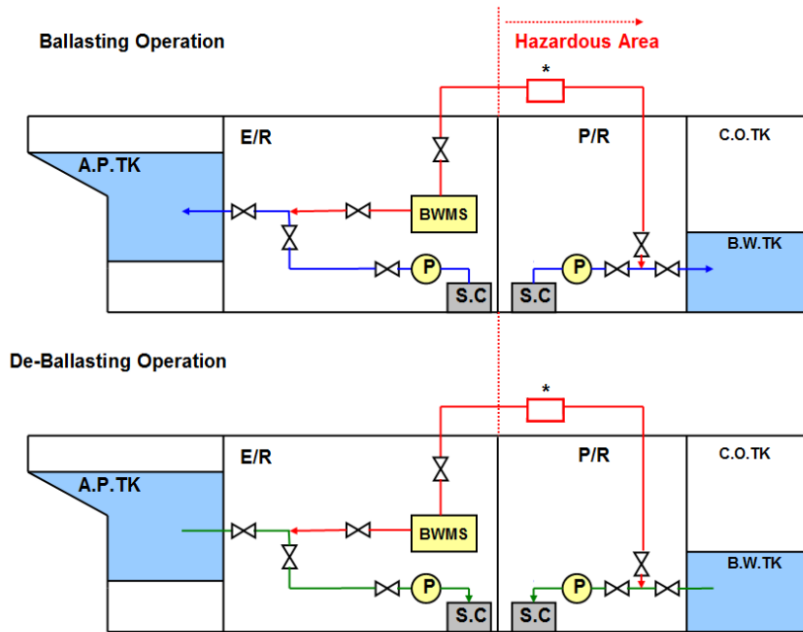

Appropriate Isolation Means: Two (2) screw down check valves in series with a spool piece or a liquid seal, or automatic double block and bleed valves

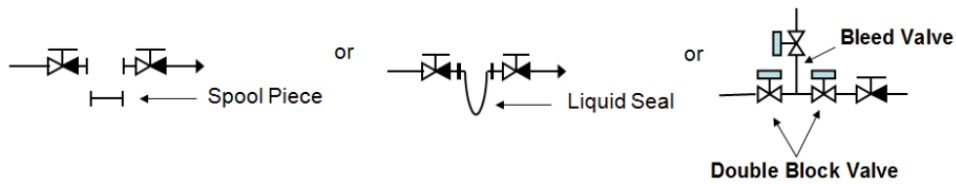

7 ECO REC

7.1 Basic Requirements

- .1 Recycling of Ships shall be performed in accordance with the provisions of *International Convention for the Safe and Environmentally Sound Recycling of Ships*.
- .2 To obtain *International Certificate on Inventory of Hazardous Materials* or *International Ready for Recycling Certificate*, survey shall be conducted in accordance with MEPC. 222(64).
- .3 An Inventory of Hazardous Materials for all merchant ship above 500 GT shall be prepared and certified (*Statement of compliance*).
- .4 Hazardous materials listed in Table A (MEPC.58/3/2) of the related guidelines must **not** be present on board new ships. Hazardous materials listed in Table A and Table B (MEPC.58/3/2) shall be identified, quantified and documented according to the guidelines if present on board.

List of amendments effective as of 1 January 2017

<i>Item</i>	<i>Title/Subject</i>	<i>Source</i>
3.4.2.2 3.4.4 4.2.1.3 6.1.3	IMO resolutions updated	PRS
6	Definitions	UR M74 Rev.1
6.4	Installation	
6.5	Additional requirements for tankers	
6.6	Ventilation	
6.7	Special requirements	
6.8	Automation	