



RULES
PUBLICATION 8/P

CALCULATION OF CRANKSHAFTS FOR I.C. ENGINES

July
2024

Publications P (Additional Rule Requirements) issued by Polski Rejestr Statków complete or extend the Rules and are mandatory where applicable.

GDAŃSK

Publication 8/P – Calculations of Crankshafts for I.C. Engines – July 2024, is an extension of the requirements contained in *Part VI – Machinery Installations and Refrigerating Plants* and *Part VII – Machinery, Boilers and Pressure Vessels*, of the *Rules for Classification and Construction of Sea-going Ships*.

This *Publication* was approved by PRS Executive Board on 11 June 2024 and enters into force on 1 July 2024.

This *Publication* replaces *Publication 8/P – Calculation of Crankshafts for Diesel Engines – January 2021*.

© Copyright by Polish Register of Shipping*, 2024

* *Polish Register of Shipping* means *Polski Rejestr Statków S.A.*, seated in Gdańsk, al. gen. Józefa Hallera 126, 80-416 Gdańsk, Poland, registered in the Register of Entrepreneurs of the National Court Register, under entry number 0000019880. Polish Register of Shipping, its affiliates and subsidiaries, their respective officers, employees or agents are, individually and collectively, referred to as Polish Register of Shipping or as PRS for short.

CONTENTS

	Page
1 General Provisions	5
1.1 Application	5
1.2 Principles of Calculations.....	5
1.3 Drawings and Particulars to be Submitted	6
2 Calculation of Stresses	7
2.1 Calculation of Alternating Stresses Due to Bending Moments and Radial Forces	7
2.2 Calculation of Alternating Torsional Stresses	12
3 Evaluation of Stress Concentration Factors	13
3.1 General	13
3.2 Crankpin Fillet	15
3.3 Journal Fillet (not applicable to semi-built crankshafts)	16
3.4 Outlet of Crankpin Oil Bore	16
4 Additional Bending Stresses	17
5 Calculation of Equivalent Alternating Stress	17
5.1 General	17
5.2 Equivalent Alternating Stress	17
6 Calculation of Fatigue Strength	18
7 Calculation of Shrink-Fits in Semi-Built Crankshafts	18
7.1 General	18
7.2 Maximum Permissible Hole in the Journal Pin	19
7.3 Necessary Minimum Oversize of Shrink-fit	20
7.4 Maximum Permissible Oversize of Shrink-fit	20
8 Acceptability Criteria	20
Appendix I Definition of Stress Concentration Factors in crankshaft fillets	21
Appendix II Stress Concentration Factors and Stress Distribution at the Edge of Oil Drillings	22
Appendix III Guidance for Calculation of Stress Concentration Factors in the Web Fillet Raddi for Crankshafts by Utilizing Finite Element Method	23
Appendix IV Guidance for Evaluation of Fatigue Tests	29
Appendix V Guidance for Calculation of Surface Treated Fillets and Oil Outlets	39
Appendix VI Guidance for Calculation of Stress Concentration Factors in the Oil Bore Outlets of Crankshafts through Utilisation of Finite Element Method	50

1 GENERAL PROVISIONS

1.1 Application

1.1.1 The requirements specified in the present *Publication* are applicable to determining the dimensions of crankshafts of diesel engines intended for propulsion and auxiliary purposes, where the engines are capable of continuous operation at their rated power when running at rated speed.

Crankshafts which do not comply with the requirements specified in the present *Publication* are subject to PRS' consideration in each particular case. It is required that detailed, as far as practicable, calculations/analysis or measurements, shall be submitted to PRS.

In the case where:

- a crankshaft design involves the use of surface treated fillets,
- fatigue parameter influences are tested,
- working (actual) stresses are measured,

PRS may, after analysis of the above particulars, approve the crankshaft concerned.

1.1.2 The requirements specified in the present *Publication* apply to solid-forged and semi-built crankshafts of forged or cast steel, with one crank throw between the main bearings.

1.2 Principles of Calculations

The design of crankshaft is based on an evaluation of safety against fatigue in the highly stressed areas.

The calculation is also based on the assumption that the areas exposed to highest stresses are:

- fillet transitions between the crankpin and web, as well as between the journal and web,
- outlets of crankpin oil bores.

When journal diameter is equal or larger than the crankpin one, the outlets of main journal oil bores shall be formed in a similar way to the crankpin oil bores, otherwise separate documentation of fatigue safety may be required.

The outlets of oil bores into crankpins and journals shall be so formed that the fatigue strength safety factor in way of the bores will be not less than that accepted in the above-mentioned fillets. When requested by PRS, the engine manufacturer shall submit the oil bore design supporting documentation.

In the case of solid crankshafts, the calculations shall be made for:

- the crankpin fillet,
- the journal fillet.

In the case of semi-built crankshafts, the calculations shall be made for the crankpin fillet only, provided the requirements, specified in paragraph 7.2, concerning the shrink-fit of semi-built crankshafts are complied with.

Calculation of concentrated stresses and their superposition in accordance with the given formulae allow to calculate the equivalent alternating stresses.

The equivalent alternating stress shall be compared with the fatigue bending strength of the selected crankshaft material. This comparison will show whether or not the crankshaft concerned is dimensioned adequately.

The calculations shall be made for the loads occurring during the engine operation at the engine rated power and at rated speed.

1.3 Drawings and Particulars to be Submitted

For the calculation of crankshafts, the engine manufacturer shall submit the following particulars and drawings:

- rated power [kW],
- rated speed [rpm],
- type designation and kind of engine (in-line engine, V-type engine with forked connecting rods, articulated-type connecting rods),
- operating and combustion method (2-stroke or 4-stroke cycle/direct injection, precombustion chamber, etc.)
- number of cylinders,
- crankshaft drawing, which must contain all data in respect of the geometrical configurations of the crankshaft,
- direction of rotation (see Fig. 1.3-1),
- firing order with the respective ignition intervals and, where necessary, V-angle α_v (see Fig. 1.3-1),

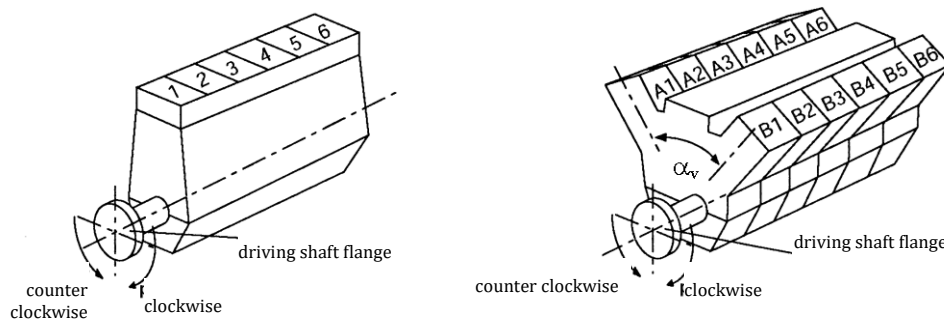

Fig. 1.3-1. Cylinders configuration

- particulars for determining alternating torsional stresses, see paragraph 2.2,
- for the engine rated power and rated speed – radial components of the gas and inertia forces, within one working cycle, acting on the crankpin at equidistant intervals of the crank angle. (The intervals shall not be greater than 5° . In the case of V-type engines, the V-angle shall be integrally divisible by the intervals and the simultaneous radial components shall be added algebraically and expressed as a combined force. Where the combined radial forces acting on particular crankpins vary due to firing order, the total radial force for which $P_{\max} - P_{\min}$ in the engine working cycle is the greatest, shall be taken),
- the permissible, assumed by the manufacturer, total alternating torsional stresses from the crankshaft and engine occurring in the cylindrical parts of the crankpin and journal,
- cylinder diameter [mm],
- stroke [mm],
- maximum cylinder pressure P_{\max} [MPa],
- charge air pressure [MPa] (before inlet valve or scavenge port, whichever applies),
- nominal compression ratio [-]
- connecting rod length L_H [mm],
- all individual reciprocating masses acting on one crank [kg],
- for engines with articulated-type connecting rod (see Fig. 1.3-2):
 - distance to link point L_A [mm],
 - link angle α_N [°],
 - link rod length L_N [mm],

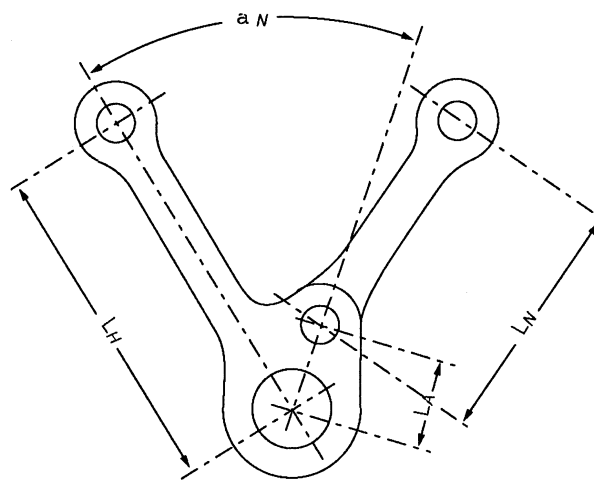

Fig. 1.3-2. Articulated-type connecting rod

- for the cylinder with articulated-type connecting-rod:
 - maximum cylinder pressure P_{\max} [MPa],
 - charge air pressure [MPa] (before inlet valve or scavenge port, whichever applies),
- mechanical properties of material (minimum values obtained from longitudinal test specimens), required by PRS:
 - material designation (according to PN or EN, or DIN, or ISO or AISI, etc.),
 - tensile strength [MPa],
 - yield strength [MPa],
 - reduction in area at break [%],
 - elongation A_5 [%],
 - impact energy KV [J],
 - material casting process (open-hearth furnace, electric furnace, etc.),
 - type of forging (free form forged, continuous grain flow forged, drop-forged, etc. with forging process description),
 - every surface treatment affecting fillets or oil holes shall be specified as to enable calculation according to Appendix V;
- particulars for determining alternating torsional stresses, see paragraph 2.2.

2 CALCULATION OF STRESSES

2.1 Calculation of Alternating Stresses Due to Bending Moments and Radial Forces

2.1.1 Assumptions

The calculation is based on a statically determined system, composed of a single crank throw, supported in the centre of adjacent main journals. The crank throw is subject to the alternating gas and inertia forces.

The bending length is taken as distance L_3 , shown in Fig. 2.1.1.

Bending moments, M_B and M_{BT} , are calculated in the relevant section based on triangular bending moment diagrams due to the radial component F_R and tangential component F_T of the connecting-rod force, respectively, see Fig. 2.1.1. For crank throws with two connecting-rods acting upon one crankpin, the relevant bending moments are obtained by superposition of the two triangular bending moment diagrams according to phase.

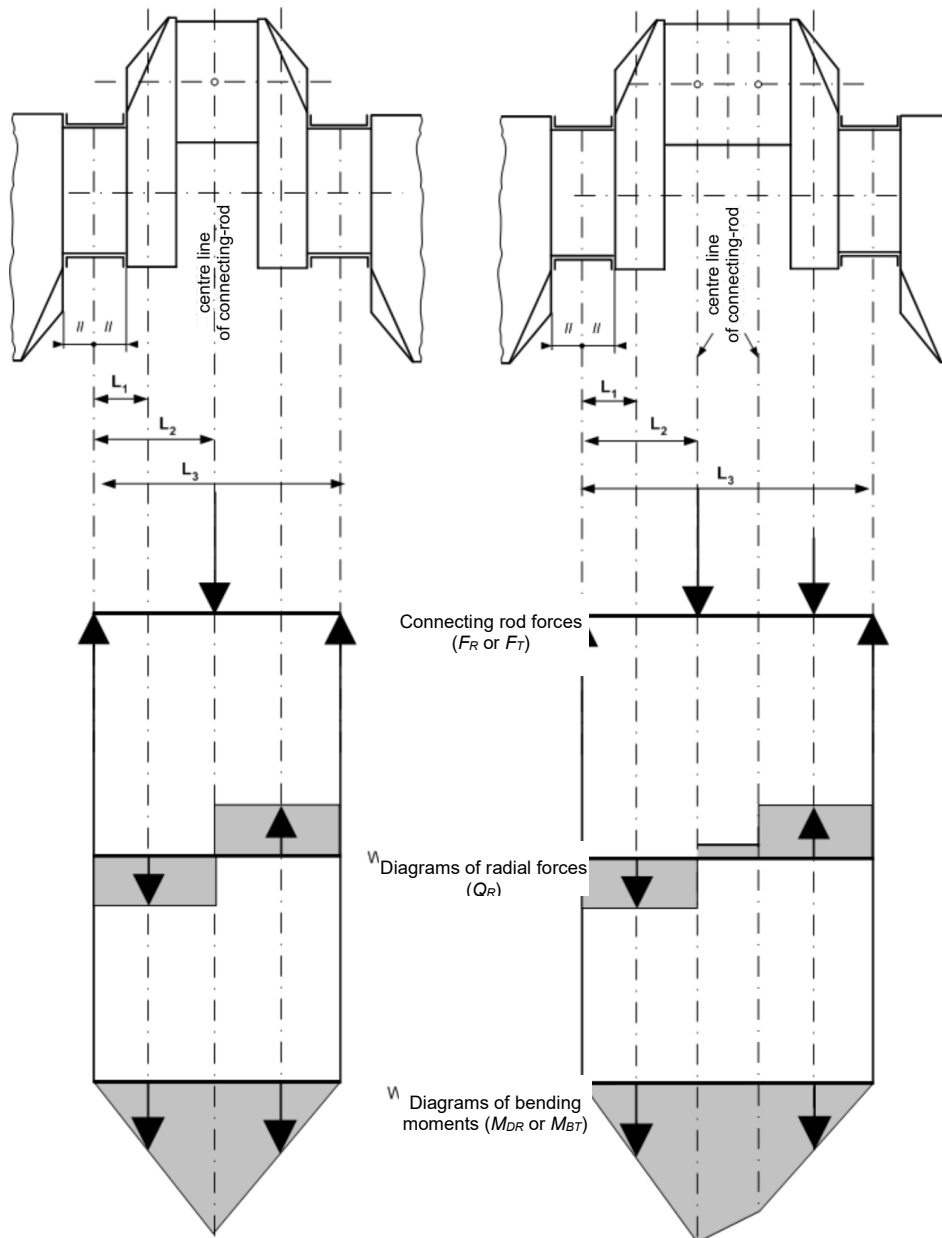

Fig. 2.1.1.1. Crank throw for in-line engine and for V-type engine with 2 adjacent connecting rods

L_1 – distance between main journal centre line and crankweb centre (see also Fig 2.1.1.1 for crankshaft without overlap)

L_2 – distance between main journal centre line and connecting-rod centre

L_3 – distance between two adjacent main journal centre lines.

2.1.1.1 Bending Moments and Radial Forces Acting in Web

The bending moment M_{BRF} and the radial force Q_{RF} are taken as acting in the centre of the solid web (distance L_1) and are derived from the radial component of the connecting-rod force.

The alternating bending and compressive stresses due to bending moments and radial forces shall be related to the cross-section of the crank web. This reference section results from the web thickness W and the web width B (see Fig. 2.1.1.1).

Mean bending stresses are neglected.

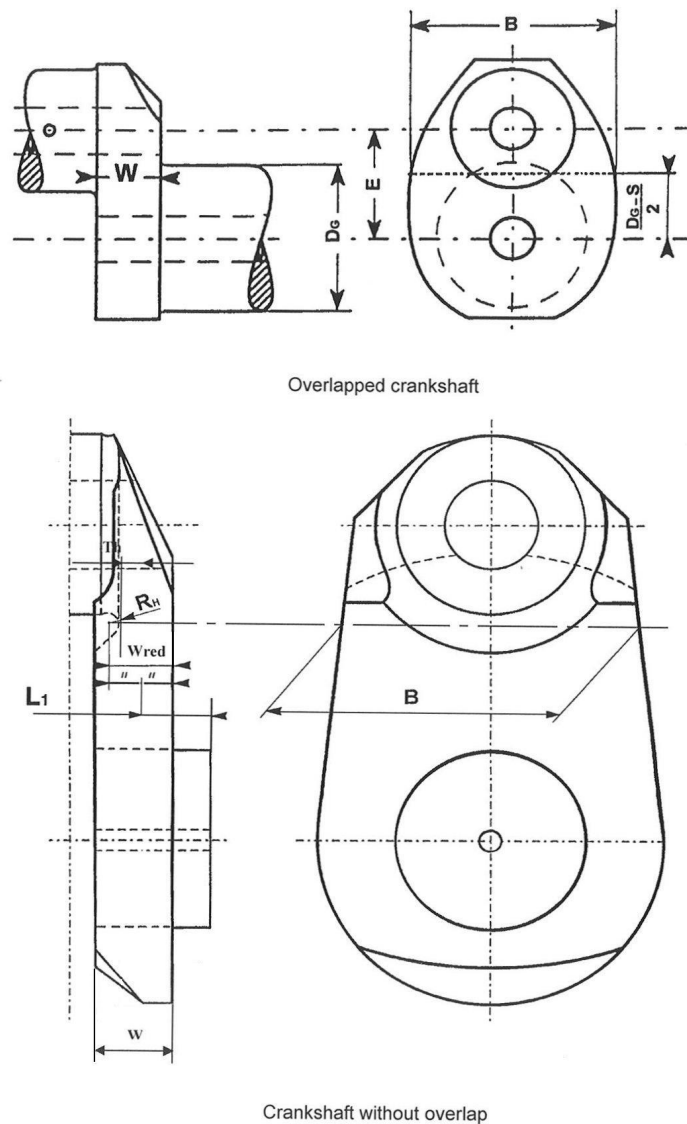

Fig. 2.1.1.1. Reference area of crank web cross-section

2.1.1.2 Bending Moments Acting in Outlet of Crankpin Oil Bore

The two relevant bending moments are taken in the crankpin cross-section through the oil bore (Fig. 2.1.1.2):

M_{BRO} – the bending moment of the radial component of the connecting-rod force [Nm],

M_{BTO} – the bending moment of the tangential component of the connecting-rod force [Nm].

The alternating stresses due to these bending moments shall be related to the cross-sectional area of the axially bored crankpin.

Mean bending stresses are neglected.

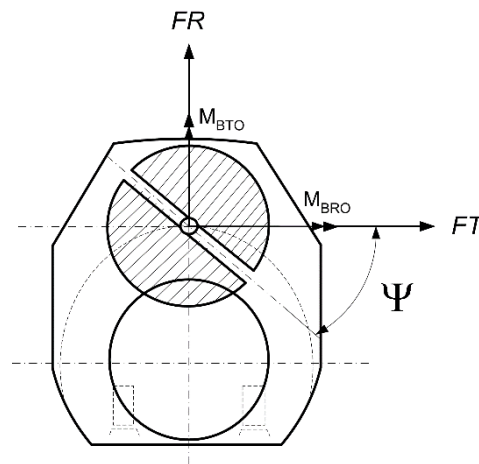

Fig. 2.1.1.2. Crankpin section through the oil bore

2.1.2 Calculation of Nominal Alternating Bending and Compressive Stresses in Web

Generally, the radial and tangential forces due to gas and inertia loads acting upon the crankpin at each connecting-rod position will be calculated over one working cycle. Upon PRS' agreement, a simplified procedure for calculating these components may be used.

Using the forces calculated over one working cycle and taking account of the distance from the main bearing midpoint, the time curve of the bending moments M_{BRF} , M_{BRO} , M_{BTO} and radial forces Q_{RF} will then be calculated in accordance with paragraphs 2.1.1.1 and 2.1.1.2.

In the case of V-type engines, the bending moments – progressively calculated from the gas and inertia forces – of the two cylinders acting on one crank throw shall be superposed according to phase. Different designs (forked connecting-rod, articulated-type connecting-rod or adjacent connecting-rods) shall be taken into account.

Where there are cranks of different geometrical configurations in one crankshaft, the calculation shall cover all crank variants.

The decisive alternating values will then be calculated in accordance with the formula:

$$[X_N] = \pm \frac{1}{2} [X_{\max} - X_{\min}]$$

where:

X_N – is considered as alternating force, moment or stress,

X_{\max} – maximum value within one working cycle,

X_{\min} – minimum value within one working cycle.

2.1.2.1 Nominal Alternating Bending and Compressive Stresses in Web Cross-Section

Nominal alternating bending and compressive stresses shall be calculated in accordance with the formulae:

$$\sigma_{BFN} = \pm \frac{M_{BRFN}}{W_{eqw}} \cdot 10^3 \cdot K_e \quad [\text{MPa}] \quad (2.1.2.1-1)$$

$$\sigma_{QFN} = \pm \frac{Q_{RFN}}{F} \cdot 10^3 \cdot K_e \quad [\text{MPa}] \quad (2.1.2.1-2)$$

where:

σ_{BFN} – nominal alternating bending stress related to the web, [MPa],

M_{BRFN} – alternating bending moment related to the centre of the web (see Fig. 2.1.1), [Nm]

$$M_{BRFN} = \pm \frac{1}{2} [M_{BRFmax} - M_{BRFmin}] \quad [\text{Nm}] \quad (2.1.2.1-3)$$

W_{eqw} – section modulus related to cross-section of the web, [mm³]

$$W_{eqw} = \frac{B \cdot W^2}{6} \quad [\text{mm}^3] \quad (2.1.2.1-4)$$

K_e – empirical factor considering to some extent the influence of adjacent crank and bearing restraint with:

$K_e = 0.8$ for 2-stroke engines,

$K_e = 1.0$ for 4-stroke engines,

σ_{QFN} – nominal alternating compressive stress due to radial force related to the web, [MPa],

Q_{RFN} – alternating radial force related to the web (see Fig. 2.1.1), [N]

$$Q_{RFN} = \pm \frac{1}{2} [Q_{RFmax} - Q_{RFmin}] \quad [\text{N}] \quad (2.1.2.1-5)$$

F – area related to the web cross-section [mm²]

$$F = B \cdot W \quad [\text{mm}^2] \quad (2.1.2.1-6)$$

2.1.2.2 Nominal Alternating Bending Stress in Outlet of Crankpin Oil Bore

Nominal alternating bending stress shall be determined from the formula:

$$\sigma_{BON} = \pm \frac{M_{BON}}{W_e} \cdot 10^3 \quad [\text{MPa}] \quad (2.1.2.2-1)$$

where:

σ_{BON} – nominal alternating bending stress related to the crank pin diameter, [MPa],

M_{BON} – alternating bending moment calculated at the outlet of the crankpin oil bore, [Nm]

$$M_{BON} = \pm \frac{1}{2} [M_{BOmax} - M_{BOmin}] \quad [\text{Nm}] \quad (2.1.2.2-2)$$

$$M_{BO} = (M_{BT} \cdot \cos\psi + M_{BRO} \cdot \sin\psi) \quad (2.1.2.2-3)$$

where:

ψ – angular position of oil bore (see Fig. 2.1.1.2), [°]

W_e – section modulus related to cross-section of axially bored crankpin, [mm³]

$$W_e = \frac{\pi}{32} \left[\frac{D^4 - D_{BH}^4}{D} \right] \quad [\text{mm}^3] \quad (2.1.2.2-4)$$

2.1.3 Calculation of Alternating Bending Stresses in Fillets

Calculation of stresses shall be performed for the crankpin fillet, as well as for the journal fillet.

For the crankpin fillet, alternating bending stresses shall be determined in accordance with the formula:

$$\sigma_{BH} = \pm (\alpha_B \cdot \sigma_{BN}) \quad [\text{MPa}] \quad (2.1.3-1)$$

where:

α_B – stress concentration factor for bending in the crankpin fillet (see formula 3.2-1).

For the journal fillet, alternating bending stresses shall be determined from the below formula (not applicable to semi-built crankshafts):

$$\sigma_{BG} = \pm (\beta_B \cdot \sigma_{BN} + \beta_Q \cdot \sigma_{QN}) \quad [\text{MPa}] \quad (2.1.3-2)$$

where:

β_B – stress concentration factor for bending in journal fillet (see formula 3.3-1),

β_Q – stress concentration factor for compression due to radial force in journal fillet (see formula 3.3-2).

2.1.4 Calculation of Alternating Bending Stresses in Outlet of Crankpin Oil Bore

Alternating bending stresses in outlet of crankpin oil bore shall be determined from the formula:

$$\sigma_{BO} = \pm (\gamma_B \cdot \sigma_{BON}) \quad [\text{MPa}] \quad (2.1.4-1)$$

where:

γ_B – stress concentration factor for bending in crankpin oil bore (see formula 3.4-1).

2.2 Calculation of Alternating Torsional Stresses

2.2.1 General

The calculation of nominal alternating torsional stresses shall be carried out by the engine manufacturer in accordance with paragraph 2.2.2.

The manufacturer shall specify the maximum nominal alternating torsional stress.

2.2.2 Calculation of Nominal Alternating Torsional Stresses

The maximum and minimum torques shall be determined for every mass point of the complete dynamic system and for the entire speed range by means of a harmonic synthesis of the forced vibrations from the 1st order up to and including the 15th order for 2-stroke cycle engines and from the 0.5th order up to and including the 12th order for 4-stroke cycle engines. While doing so, allowance shall be made for the damping that exists in the system and for unfavourable conditions (misfiring in one of the cylinders). The speed step calculation shall be so selected that any resonance found in the operational speed range of the engine shall be detected. Points creating the diagram shall be clearly marked.

Where barred speed ranges are necessary, they shall be so arranged that satisfactory operation is possible despite their existence. There shall be no barred speed ranges above a speed ratio of $\lambda \geq 0.8$ for normal firing conditions.

The nominal alternating torsional stress in every mass point, which is essential to the assessment, results from the below formula:

$$\tau_N = \pm \frac{M_{TN}}{W_p} \cdot 10^3 \quad [\text{MPa}] \quad (2.2.2-1)$$

$$M_{TN} = \pm \frac{1}{2} [M_{T_{max}} - M_{T_{min}}] \quad [\text{Nm}] \quad (2.2.2-2)$$

$$W_p = \frac{\pi}{16} \left(\frac{D^4 - D_{BH}^4}{D} \right) \quad \text{or}$$

$$W_p = \frac{\pi}{16} \left(\frac{D_G^4 - D_{BG}^4}{D_G} \right) \quad [\text{mm}^3] \quad (2.2.2-3)$$

where:

M_T – nominal alternating torque in the crankpin or journal [Nm],

W_p – polar section modulus related to cross-section of axially bored crankpin or bored journal [mm³],

$M_{T_{max}}$, $M_{T_{min}}$ – maximum and minimum values of the torque [Nm].

For the purpose of the crankshaft assessment, the nominal alternating torsional stress considered in further calculations is the highest value, calculated according to the above method, occurring at the most torsionally loaded mass point of the crankshaft system.

Where barred speed ranges exist, the torsional stresses within these ranges shall not be considered for assessment calculations.

The approval of crankshaft will be based on the installation having the largest nominal alternating torsional stress (but not exceeding the maximum figure specified by engine manufacturer).

For each installation, it shall be ensured by suitable calculation that the approved nominal alternating torsional stress is not exceeded. This calculation shall be submitted to PRS for assessment.

2.2.3 Calculation of Alternating Torsional Stresses in Fillets and Outlet of Crankpin Oil Bore

The calculation of alternating torsional stresses for the crankpin fillet shall be performed in accordance with the formula:

$$\tau_H = \pm (\alpha_T \cdot \tau_N) \quad [\text{MPa}] \quad (2.2.3-1)$$

where:

α_T – stress concentration factor for torsion in crankpin fillet (see formula 3.2-2).

The calculation of alternating torsional stresses for the journal fillet shall be performed in accordance with the formula:

$$\tau_G = \pm (\beta_T \cdot \tau_N) \quad [\text{MPa}] \quad (2.2.3-2)$$

where:

β_T – stress concentration factor for torsion in journal fillet (see formula 3.3-3).

The calculation of alternating torsional stresses for the crankpin oil bore shall be performed in accordance with the formula:

$$\sigma_{TO} = \pm (\gamma_T \cdot \tau_N) \quad [\text{MPa}] \quad (2.2.3-3)$$

where:

γ_T – stress concentration factor for torsion in outlet of crankpin oil bore (see formula 3.4-2).

3 EVALUATION OF STRESS CONCENTRATION FACTORS

3.1 General

The stress concentration factors shall be evaluated in accordance with the formulae given in paragraphs 3.2, 3.3 and 3.4. The stress concentration factor formulae concerning the oil bore are only applicable to a radially drilled oil hole.

Where the geometry of the crankshaft is outside the boundaries of the analytical stress concentration factors (**SCF**), the calculation method detailed in Appendix III may be used.

The stress concentration factor for bending (α_B, β_B) is defined as the ratio of the maximum equivalent stress (Von Mises) – occurring in the fillets under bending load – to the nominal bending stress related to the web cross-section (see Appendix I).

The stress concentration factor for torsion (α_T, β_T) is defined as the ratio of the maximum equivalent shear stress – occurring in the fillets under torsional load – to the nominal torsional stress related to the axially bored crankpin or journal cross-section (see Appendix I).

The stress concentration factor for compression (β_Q) in the journal fillet is defined as the ratio of the maximum equivalent stress (Von Mises) – occurring in the fillet due to the radial force – to the nominal compressive stress related to the web cross-section.

The stress concentration factors for bending (γ_B) and torsion (γ_T) are defined as the ratio of the maximum principal stress – occurring at the outlet of the crankpin oil-hole under bending and torsional loads – to the corresponding nominal stress related to the axially bored crankpin cross-section (see Appendix II).

When reliable measurements and/or calculations are available, which can allow direct assessment of stress concentration factors, the relevant documents and their analysis method have to be submitted to Classification Societies in order to demonstrate their equivalence to present rules evaluation. This is always to be performed when dimensions are outside of any of the validity ranges for the empirical formulae presented in 3.2 to 3.4.

Appendix III and VI describes how FE analyses can be used for the calculation of the stress concentration factors. Care should be taken to avoid mixing equivalent (von Mises) stresses and principal stresses.

All crank dimensions necessary for the calculation of stress concentration factors are shown in Fig. 3.1.

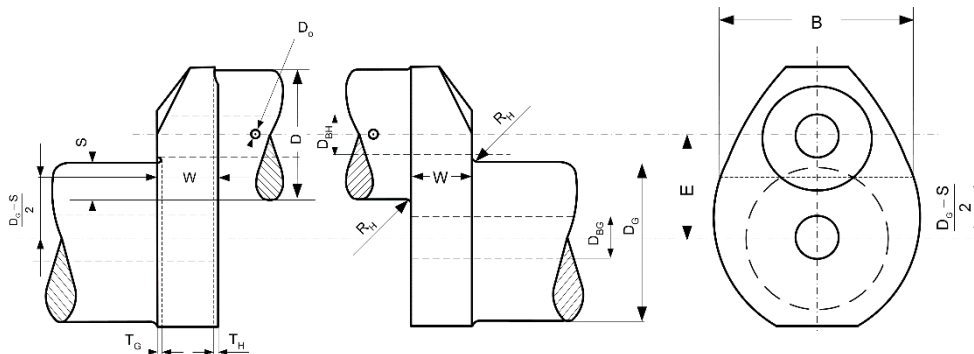

Fig 3.1. Crank dimensions necessary for the calculation of stress concentration factors

- D – crankpin diameter [mm],
- D_{BH} – diameter of axial bore in crankpin [mm],
- D_o – diameter of oil bore in crankpin [mm],
- R_H – fillet radius of crankpin [mm],
- T_H – recess of crankpin fillet [mm],
- D_G – journal diameter [mm],
- D_{BG} – diameter of axial bore in journal [mm],
- R_G – fillet radius of journal [mm],
- T_G – recess of journal fillet [mm],
- E – pin eccentricity [mm],
- S – pin overlap [mm]:

$$S = \frac{D+D_G}{2} - E \quad (3.1-1)$$

- $W^{(*)}$ – web thickness [mm],
- $B^{(*)}$ – web width [mm].

- (*) In the case of 2-stroke semi-built crankshafts:
- when $T_H > R_H$, the web thickness shall be considered as equal to:
 $W_{red} = W - (T_H - R_H)$ [mm] (see Fig. 2.1.1.1);
 - web width B shall be taken in accordance with Fig. 2.1.1.1.

For the calculation of stress concentration factors, the related dimensions, specified in Table 3.1, shall be applied.

Table 3.1

Crankpin fillet	Journal fillet
$r = R_H/D$	$r = R_G/D$
	$s = S/D$
	$w = W/D$ crankshafts with overlap
	$w = W_{red}/D$ crankshafts without overlap
	$b = B/D$
	$d_o = D_o/D$
	$d_G = D_{BH}/D$
	$d_H = D_{BG}/D$
	$t_H = T_H/D$
	$t_G = T_G/D$

The stress concentration factors are valid for the ranges of related dimensions for which the investigations have been carried out. The ranges are as follows:

$$s \leq 0.5$$

$$0.2 \leq w \leq 0.8$$

$$1.1 \leq b \leq 2.2$$

$$0.03 \leq r \leq 0.13$$

$$0 \leq d_G \leq 0.8$$

$$0 \leq d_H \leq 0.8$$

$$0 \leq d_o \leq 0.2.$$

Low range of s may be extended down to large negative values if:

- the calculated $f(recess) < 1$, then factor $f(recess)$ shall not be taken into account ($f(recess) = 1$),
- $s < -0.5$, then $f(s, w)$ and $f(r, s)$ shall be evaluated replacing the actual value of s by -0.5 .

3.2 Crankpin Fillet

The stress concentration factor for bending, α_B , shall be determined from the formula:

$$\alpha_B = 2.6914 \cdot f(s, w) \cdot f(w) \cdot f(b) \cdot f(r) \cdot f(d_G) \cdot f(d_H) \cdot f(recess) \quad (3.2-1)$$

$$f(s, w) = -4.1883 + 29.2004 \cdot w - 77.5925 \cdot w^2 + 91.9454 \cdot w^3 - 40.0416 \cdot w^4 + (1-s) \cdot (9.5440 - 58.3480 \cdot w + 159.3415 \cdot w^2 - 192.5846 \cdot w^3 + 85.2916 \cdot w^4) + (1-s)^2 \cdot (-3.8399 + 25.0444 \cdot w - 70.5571 \cdot w^2 + 87.0328 \cdot w^3 - 39.1832 \cdot w^4)$$

$$f(w) = 2.1790 \cdot w^{0.7171}$$

$$f(b) = 0.6840 - 0.0077 \cdot b + 0.1473 \cdot b^2$$

$$f(r) = 0.2081 \cdot r^{-0.5231}$$

$$f(d_G) = 0.9993 + 0.27 \cdot d_G - 1.0211 \cdot d_G^2 + 0.5306 \cdot d_G^3$$

$$f(d_H) = 0.9978 + 0.3145 \cdot d_H - 1.5241 \cdot d_H^2 + 2.4147 \cdot d_H^3$$

$$f(recess) = 1 + (t_H + t_G) \cdot (1.8 + 3.2 \cdot s)$$

The stress concentration factor for torsion, α_T , shall be determined from the formula:

$$\alpha_T = 0.8 \cdot f(r, s) \cdot f(b) \cdot f(w) \quad (3.2-2)$$

where:

$$f(r, s) = r^{[-0.322 + 0.1015 \cdot (1-s)]}$$

$$f(b) = 7.8955 - 10.654 \cdot b + 5.3482 \cdot b^2 - 0.857 \cdot b^3$$

$$f(w) = w^{-0.145}$$

3.3 Journal Fillet (not applicable to semi-built crankshafts)

The stress concentration factor for bending, β_B , shall be determined from the formula:

$$\beta_B = 2.7146 \cdot f_B(s,w) \cdot f_B(w) \cdot f_B(b) \cdot f_b(r) \cdot f_B(d_G) f_B(d_H) \cdot f(recess) \quad (3.3-1)$$

where:

$$f_B(s,w) = -1.7625 + 2.9821 \cdot w - 1.5276 \cdot w^2 + (1-s) \cdot (5.1169 - 5.8089 \cdot w + 3.1391 \cdot w^2) + (1-s)^2 \cdot (-2.1567 + 2.3297 \cdot w - 1.2952 \cdot w^2)$$

$$f_B(w) = 2.2422 \cdot w^{0.7548}$$

$$f_B(b) = 0.5616 + 0.1197 \cdot b + 0.1176 \cdot b^2$$

$$f_B(r) = 0.1908 \cdot r^{(-0.5568)}$$

$$f_B(d_G) = 1.0012 - 0.6441 \cdot d_G + 1.2265 \cdot d_G^2$$

$$f_B(d_H) = 1.0022 - 0.1903 \cdot d_H + 0.0073 \cdot d_H^2$$

$$f(recess) = 1 + (t_H + t_G) \cdot (1.8 + 3.2 \cdot s)$$

The stress concentration factor for compression due to the radial force, β_Q , shall be determined from the formula:

$$\beta_Q = 3.0128 \cdot f_Q(s) \cdot f_Q(w) \cdot f_Q(b) \cdot f_Q(r) \cdot f_Q(d_H) \cdot f(recess) \quad (3.3-2)$$

where:

$$f_Q(s) = 0.4368 + 2.1630(1-s) - 1.5212(1-s)^2$$

$$f_Q(w) = \frac{w}{0.0637 + 0.9369 \cdot w}$$

$$f_Q(b) = -0.5 + b$$

$$f_Q(r) = 0.5331 \cdot r^{(-0.2038)}$$

$$f_Q(d_H) = 0.9937 - 1.1949 \cdot d_H + 1.7373 \cdot d_H^2$$

$$f(recess) = 1 + (t_H + t_G) \cdot (1.8 + 3.2 \cdot s)$$

The stress concentration factor for torsion, β_T , shall be determined from the formula:

$$\beta_T = \alpha_T \quad (3.3-3)$$

if the diameters and fillet radii of crankpin and journal are the same, or

$$\beta_T = 0.8 \cdot f(r,s) \cdot f(b) \cdot f(w)$$

if crankpin and journal diameters and/or radii are of different sizes,

where:

$f(r, s)$, $f(b)$ and $f(w)$ shall be determined in accordance with paragraph 3.2 (see calculation of α_T), however, the radius of the journal fillet shall be related to the journal diameter:

$$r = \frac{R_G}{D_G} \quad (3.3-4)$$

3.4 Outlet of Crankpin Oil Bore

The stress concentration factor for bending, γ_B , shall be determined from the formula:

$$\gamma_B = 3 - 5.88 \cdot d_o + 34.6 \cdot d_o^2 \quad (3.4-1)$$

The stress concentration factor for torsion, γ_T , shall be determined from the formula:

$$\gamma_T = 4 - 6 \cdot d_o + 30 \cdot d_o^2 \quad (3.4-2)$$

4 ADDITIONAL BENDING STRESSES

In addition to the alternating bending stresses in fillets (see 2.1.3), further bending stresses due to misalignment and bedplate deformation, as well as due to axial and bending vibrations shall be increased by applying σ_{add} specified in Table 4.

Table 4

Type of engine	σ_{add} [MPa]
Crosshead engines	± 30 (*)
Trunk piston engines	± 10

(*) The additional stress of ± 30 [MPa] involves two components:

- 1) an additional stress of ± 20 [MPa] resulting from axial vibrations,
- 2) an additional stress of ± 10 [MPa] resulting from misalignment / bedplate deformation.

It is recommended that a value of ± 20 [MPa] be used for the axial vibration component for assessment purposes where axial vibration calculation results of the complete dynamic system (engine/shafting/ gearing/propeller) are not available. Where axial vibration calculation results of the complete dynamic system are available, the calculated figures may be used instead.

5 CALCULATION OF EQUIVALENT ALTERNATING STRESS

5.1 General

The equivalent alternating stress shall be calculated for the crankpin fillet, as well as for the journal fillet by using the Von Mises criterion.

In the fillets, bending and torsion lead to two different biaxial stress fields which can be represented by a Von Mises equivalent stress with the additional assumptions that bending and torsion stresses are time phased and the corresponding peak values occur at the same location (see Appendix I).

At the oil hole outlet, bending and torsion lead to two different stress fields which can be represented by an equivalent principal stress equal to the maximum of principal stress resulting from combination of these two stress fields with the assumption that bending and torsion are time phased (see Appendix II).

The above two different ways of equivalent stress evaluation both lead to stresses which may be compared to the same fatigue strength value of crankshaft assessed according to the Von Mises criterion.

5.2 Equivalent Alternating Stress

The equivalent alternating stress is calculated in accordance with the following formulae:

– for the crankpin fillet:

$$\sigma_v = \pm \sqrt{(\sigma_{BH} + \sigma_{add})^2 + 3 \cdot \tau_H^2} \quad [\text{MPa}] \quad (5.2-1)$$

– for the journal fillet:

$$\sigma_v = \pm \sqrt{(\sigma_{BG} + \sigma_{add})^2 + 3 \cdot \tau_G^2} \quad [\text{MPa}] \quad (5.2-2)$$

– for the outlet of crankpin oil bore:

$$\sigma_v = \pm \frac{1}{3} \cdot \sigma_{BO} \cdot \left[1 + 2 \cdot \sqrt{1 + \frac{9}{4} \cdot \left(\frac{\sigma_{TO}}{\sigma_{BO}} \right)^2} \right] \quad [\text{MPa}] \quad (5.2-3)$$

6 CALCULATION OF FATIGUE STRENGTH

The fatigue strength is understood as that value of equivalent alternating stress (Von Mises) which a crankshaft can permanently withstand at the most highly stressed points.

Where the results of the crankshaft fatigue strength tests are not available, the fatigue strength may be evaluated by means of the following formulae:

– related to the crankpin diameter:

$$\sigma_{DW} = \pm K \cdot (0.42 \cdot \sigma_B + 39.3) \cdot \left[0.264 + 1.073 \cdot D^{-0,2} + \frac{785 - \sigma_B}{4900} + \frac{196}{\sigma_B} \cdot \sqrt{\frac{1}{R_X}} \right] \quad (6-1)$$

with:

$R_X = R_H$ – in the fillet area

$R_X = D_o/2$ – in the oil bore area;

– related to the journal diameter:

$$\sigma_{DW} = \pm K \cdot (0.42 \cdot \sigma_B + 39.3) \cdot \left[0.264 + 1.073 \cdot D_G^{-0,2} + \frac{785 - \sigma_B}{4900} + \frac{196}{\sigma_B} \cdot \sqrt{\frac{1}{R_G}} \right] \quad (6-2)$$

where:

σ_{DW} – allowable fatigue strength of crankshaft for bending [MPa]

K – factor for different types of crankshafts without surface treatment [-].

Values greater than 1 are only applicable to fatigue strength in fillet area.

= 1.05 for continuous grain flow forged or drop-forged crankshafts,

= 1.0 for free form forged crankshafts (without continuous grain flow),

K – factor for cast steel crankshafts with cold rolling treatment in fillet area:

= 0.93 for cast steel crankshafts manufactured by companies using a PRS approved cold rolling process.

σ_B – minimum tensile strength of crankshaft material [MPa].

For other parameters – see paragraph 3.1.

Where a surface treatment process is applied, it must be approved by PRS. Guidance for calculation of surface treated fillets and oil bore outlets is presented in Appendix V.

The above formulae are subject to the following conditions:

- surfaces of the fillet, the outlet of the oil bore and inside the oil bore (down to a minimum depth equal to 1.5 times the oil bore diameter) shall be smoothly finished;
- for calculation purposes, R_H , R_G or R_X shall be taken not less than 2 mm.

As an alternative, the fatigue strength of the crankshaft can be determined by experiment based either on full size crank throw (or crankshaft) or on specimens taken from a full size crank throw. For evaluation of test results, see Appendix IV.

7 CALCULATION OF SHRINK-FITS IN SEMI-BUILT CRANKSHAFTS

7.1 General

All crank dimensions necessary for the calculation of the shrink-fit are shown in Fig. 7.1.

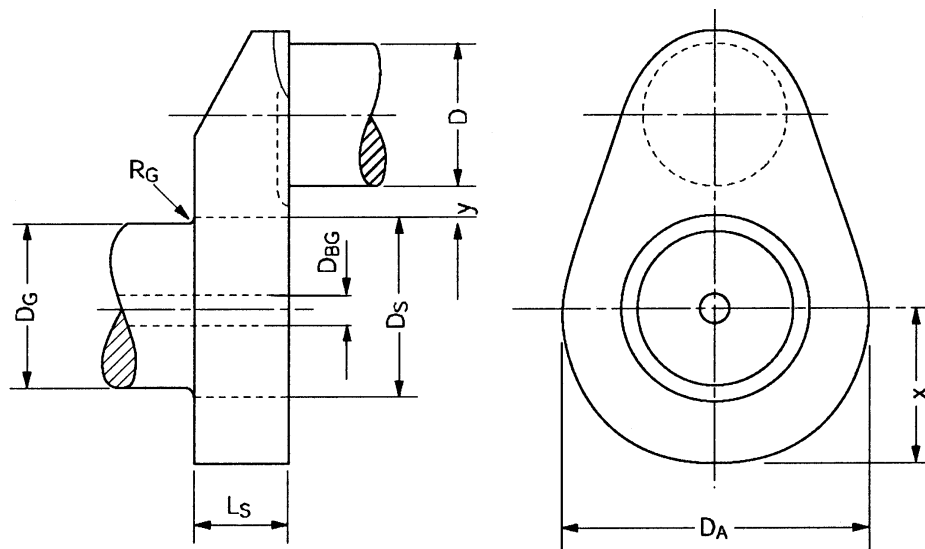

Fig. 7.1. Crank throw of semi-built crankshaft

- D_S – shrink diameter, [mm],
 L_S – length of shrink-fit, [mm],
 D_A – outside diameter of web or twice the minimum distance x , [mm], between the centre line of journals and the outer contour of web, whichever is the lesser,
 y – distance between the adjacent generating lines of journal and pin $y \geq 0.05 \cdot D_S$ [mm]. Where y is less than $0.1D_S$, special consideration shall be given to the effect of the stress due to the shrink-fit on the fatigue strength at the crankpin fillet.

For other parameters – see paragraph 3.1 and Fig. 3.1.

The radius of the transition from the journal to the shrink diameter shall comply with the following condition:

$$R_G \geq 0.015 D_G \text{ and } R_G \geq 0.5 (D_S - D_G), \text{ where the greater value shall be considered.}$$

The actual oversize Z of the shrink-fit shall be within the limits Z_{\min} and Z_{\max} calculated in accordance with paragraphs 7.3 and 7.4.

7.2 Maximum Permissible Hole in the Journal Pin

The maximum permissible hole diameter in the journal pin is calculated in accordance with the following formula:

$$D_{BG} = D_S \cdot \sqrt{1 - \frac{4000 \cdot S_R \cdot M_{\max}}{\mu \cdot \pi \cdot D_S^2 \cdot L_S \cdot \sigma_{SP}}} \quad [mm] \quad (7.2-1)$$

where:

- S_R – safety factor against slipping, however, a value not less than 2 shall be taken unless documented by experiments [-],
 M_{\max} – absolute maximum value of the torque $M_{T_{\max}}$ in accordance with paragraph 2.2.2 [Nm],
 μ – coefficient for static friction, however, a value not greater than 0.2 shall be taken unless documented by experiments [-],
 σ_{SP} – minimum yield strength of material for journal pin [MPa].

This condition serves to avoid plasticity in the hole of journal pin.

7.3 Necessary Minimum Oversize of Shrink-fit

The necessary minimum oversize is determined by the greater value calculated according to:

$$Z_{min} \geq [\text{mm}] \quad (7.3-1)$$

and

$$Z_{min} \geq \frac{4000}{\mu \cdot \pi} \cdot \frac{S_R \cdot M_{max}}{E_m \cdot D_S \cdot L_S} \cdot \frac{1 - Q_A^2 \cdot Q_S^2}{(1 - Q_A^2) \cdot (1 - Q_S^2)} [\text{mm}] \quad (7.3-2)$$

$$Q_A = D_S / D_A; Q_S = D_{BG} / D_S$$

where:

- Z_{min} – minimum oversize [mm],
- E_m – Young's modulus for crank web material [MPa],
- σ_{SW} – minimum yield strength of material for crank web [MPa],
- M_{max} – maximum torque in crankshaft [Nm],
- Q_A – web ratio [-],
- Q_S – shaft ratio [-].

7.4 Maximum Permissible Oversize of Shrink-fit

The maximum permissible oversize for a shrink-fit loaded with the maximum torque, Z_{max} , in the crankshaft shall be calculated from the formula:

$$Z_{max} \leq D_S \cdot \left(\frac{\sigma_{SW}}{E_m} + \frac{0.8}{1000} \right) [\text{mm}] \quad (7.4-1)$$

This condition serves to restrict the shrinkage induced mean stress in the fillet.

8 ACCEPTABILITY CRITERIA

Adequate dimensioning of crankshaft is evaluated on the basis of acceptability factor for the crankpin fillet and journal fillet, determined from the formula:

$$Q = \frac{\sigma_{DW}}{\sigma_v} \quad (8-1)$$

where:

- σ_{DW} – fatigue strength of the crankshaft material for the crankpin fillet and journal fillet, determined in accordance with paragraph 6, [MPa],
- σ_v – equivalent alternating stress for the crankpin fillet and journal fillet, determined in accordance with paragraph 5, [MPa].

Adequate dimensioning of the crankshaft, except shrink-fit dimensions, is ensured if the smallest of all acceptability factors satisfies the criterion:

$$Q \geq 1.15.$$

APPENDIX I

Definition of stress concentration factors in crankshaft fillets

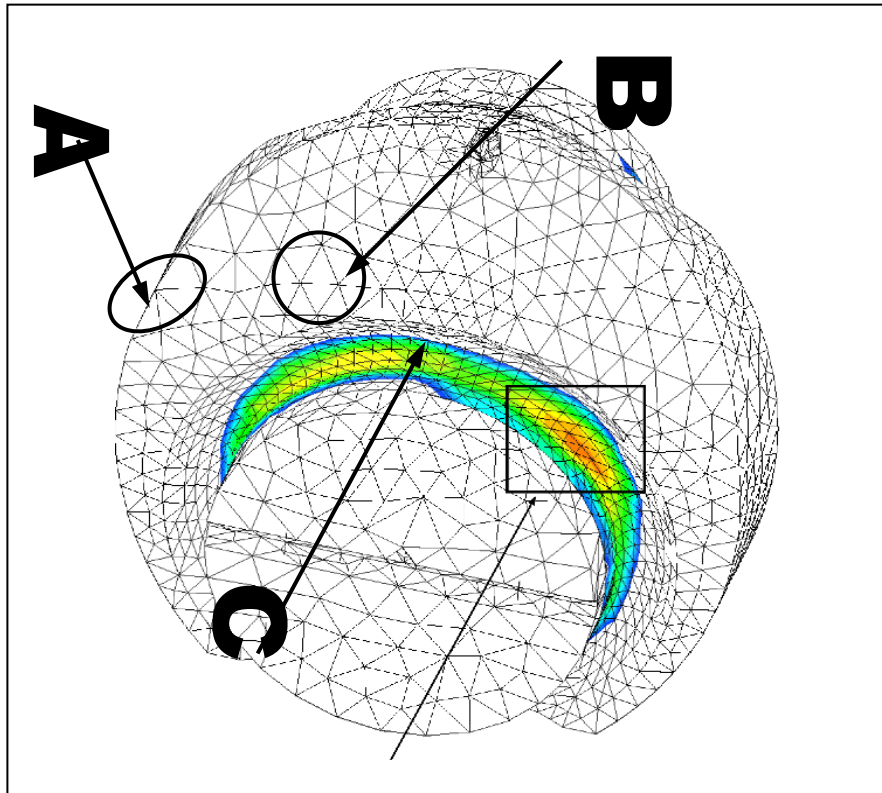

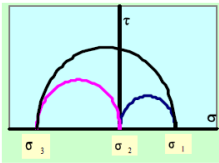
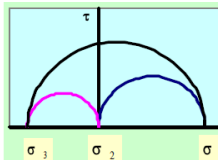
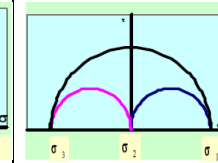
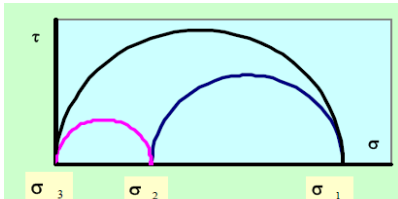
	Stress	Max $ \sigma_3 $	Max σ_1	
Torsional loading	Location of maximal stresses	A	C	B
	Typical principal stress system Mohr's circle diagram with $\sigma_2 = 0$			
	Equivalent stress and SCF	$\tau_{equiv} = 0.5 * (\sigma_1 - \sigma_3)$ $SCF = \tau_{equiv} / \tau_n$ for α_T, β_T		
Bending loading	Location of maximal stresses	A	C	B
	Typical principal stress system Mohr's circle diagram with $\sigma_3 = 0$			
	Equivalent stress and SCF	$\sigma_{equiv} = \sqrt{\sigma_1^2 + \sigma_2^2 - \sigma_1 \cdot \sigma_2}$ $W.S.N. = \sigma_{equiv} / \sigma_n$ for $\alpha_B, \beta_B, \beta_Q$		

APPENDIX II

Stress Concentration Factors and Stress Distribution at the Edge of Oil Drillings

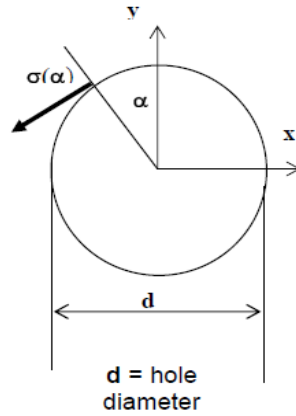

Stress type	Nominal stress tensor	Uniaxial stress distribution around the edge	Mohr's circle diagram
Tension	$\begin{bmatrix} \sigma_n & 0 \\ 0 & 0 \end{bmatrix}$	$\sigma_\alpha = \sigma_n \cdot \gamma_B / 3 [1 + 2\cos(2\alpha)]$	$\gamma_B = \sigma_{\max} / \sigma_n$ <p>for $\alpha = k \cdot \pi$</p>
Shear	$\begin{bmatrix} 0 & \tau_n \\ \tau_n & 0 \end{bmatrix}$	$\sigma_\alpha = \tau_n \cdot \gamma_B \sin(2\alpha)$	$\gamma_T = \sigma_{\max} / \tau_n$ <p>for $\alpha = \pi/4 + k \cdot (\pi/2)$</p>
Tension + shear	$\begin{bmatrix} \sigma_n & \tau_n \\ \tau_n & 0 \end{bmatrix}$	$\sigma_\alpha = \frac{\gamma_B}{3} \sigma_n \left\{ 1 + 2 \left[\cos(2\alpha) + \frac{3}{2} \frac{\gamma_T}{\gamma_B} \frac{\tau_n}{\sigma_n} \sin(2\alpha) \right] \right\}$	$\sigma_{\max} = \frac{\gamma_B}{3} \sigma_n \left[1 + 2 \sqrt{1 + \frac{9}{4} \left(\frac{\gamma_T}{\gamma_B} \frac{\tau_n}{\sigma_n} \right)^2} \right]$ <p>for $\alpha = \frac{1}{2} \text{tg}^{-1} \left(\frac{3\gamma_T \tau_n}{2\gamma_B \sigma_n} \right)$</p>

APPENDIX III

Guidance for Calculation of Stress Concentration Factors in the Web Fillet Radii of Crankshafts by Utilizing Finite Element Method

Contents

1 General	23
2 Model Requirements	23
2.1 Element Mesh Recommendations	24
2.2 Material	24
2.3 Element Mesh Quality Criteria	25
2.3.1 Principal Stresses Criterion	25
2.3.2 Averaged/Unaveraged Stresses Criterion	255
3 Load Cases	25
3.1 Torsion	255
3.2 Pure Bending (4-Point Bending)	26
3.3 Bending With Shear Force (3-Point Bending)	277
3.3.1 Method 1	28
3.3.2 Method 2	28

1 General

The objective of the analysis is to develop Finite Element Method (FEM) calculated figures as an alternative to the analytically calculated Stress Concentration Factors (SCF) at the crankshaft fillets. The analytical method is based on empirical formulae developed from strain gauge measurements of various crank geometries and accordingly the application of these formulae is limited to those geometries.

The SCFs calculated according to the rules of this document are defined as the ratio of stresses calculated by FEM to nominal stresses in both journal and pin fillets. When used in connection with the method presented in *Publication No. 8/P* or the alternative methods, von Mises stresses shall be calculated for bending and principal stresses for torsion.

The procedure, as well as evaluation guidelines are valid for both solid cranks and semi-built cranks (except journal fillets).

The analysis shall be conducted as linear elastic FE analysis, and unit loads of appropriate magnitude shall be applied for all load cases.

The calculation of SCF at the oil bores is not covered by the present *Publication*.

It is advised to check the element accuracy of the FE solver in use, e.g. by modelling a simple geometry and comparing the stresses obtained by FEM with the analytical solution for pure bending and torsion.

Boundary Element Method (BEM) may be used instead of FEM.

2 Model Requirements

The basic recommendations and perceptions for building the FE-model are presented in 2.1. It is obligatory for the final FE-model to fulfil the requirements specified in 2.3.

2.1 Element Mesh Recommendations

In order to fulfil the mesh quality criteria it is advised to construct the FE model for the evaluation of Stress Concentration Factors (**SCF**) according to the following recommendations:

- The model consists of one complete crank, from the main bearing centerline to the opposite side main bearing centreline.
- Element types used in the vicinity of the fillets:
 - 10 node tetrahedral elements,
 - 8 node hexahedral elements,
 - 20 node hexahedral elements.
- Mesh properties in fillet radii. The following applies to ± 90 degrees in circumferential direction from the crank plane:
 - Maximum element size $a = r/4$ through the entire fillet, as well as in the circumferential direction. When using 20 node hexahedral elements, the element size in the circumferential direction may be extended up to $5a$. In the case of multi-radii, fillet r is the local fillet radius. (If 8 node hexahedral elements are used, even smaller element size is required to meet the quality criteria.)
- Recommended manner for element size in fillet depth direction:
 - first layer thickness equal to element size of a ,
 - second layer thickness equal to element size of $2a$,
 - third layer thickness equal to element size of $3a$.
- Minimum 6 elements across web thickness.
- Generally, the rest of the crank should be suitable for numeric stability of the solver.
- Counterweights have to be modelled only when influencing the global stiffness of the crank significantly.
- Modelling of oil drillings is not necessary as long as the influence on global stiffness is negligible and the proximity to the fillet is more than $2r$, see Fig. 2.1.
- Drillings and holes for weight reduction have to be modelled.
- Sub-modelling may be used as far as the software requirements are fulfilled.

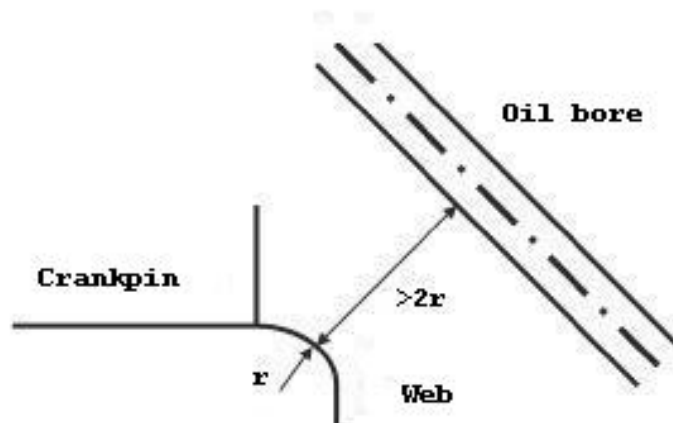

Fig. 2.1. Oil bore proximity to fillet

2.2 Material

Publication 8/P does not consider material properties such as Young's Modulus (E) and Poisson's ratio (ν). In FE analysis, those material parameters are required as strain is primarily calculated

and stress is derived from strain using the Young's Modulus and Poisson's ratio. Reliable values for material parameters have to be used, either as quoted in literature or as measured on representative material samples.

For steel, the following is advised: $E = 2.05 \cdot 10^5$ MPa and $\nu = 0.3$.

2.3 Element Mesh Quality Criteria

If the actual element mesh does not fulfil any of the following criteria at the examined area for SCF evaluation, then a second calculation with a refined mesh shall be performed.

2.3.1 Principal stresses criterion

The quality of the mesh should be assured by checking the stress component normal to the surface of the fillet radius. Ideally, this stress should be zero. With principal stresses σ_1 , σ_2 and σ_3 , the following criterion is required:

$$\min (|\sigma_1|, |\sigma_2|, |\sigma_3|) < 0.03 \cdot \max (|\sigma_1|, |\sigma_2|, |\sigma_3|)$$

2.3.2 Averaged/unaveraged stresses criterion

The criterion is based on observing the discontinuity of stress results over elements at the fillet for the calculation of SCF:

Unaveraged nodal stress results calculated from each element connected to a node, should differ less than by 5 % from the 100 % averaged nodal stress results at this node at the examined location.

3 Load Cases

To substitute the analytically determined SCF in accordance with *Publication No. 8/P*, the following load cases have to be calculated.

3.1 Torsion

The examined structure is loaded in pure torsion. In the model, surface warp at the end faces is suppressed.

Torque is applied to the central node located at the crankshaft axis. This node acts as the master node with 6 degrees of freedom and is connected rigidly to all nodes of the end face.

Boundary and load conditions are valid for both in-line and V-type engines.

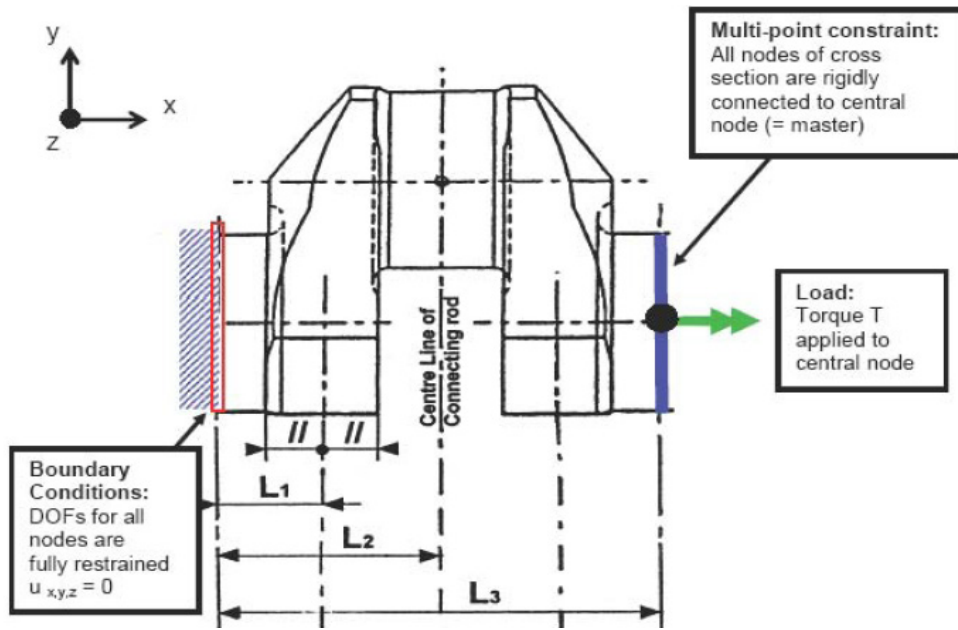

Fig. 3.1. Boundary and load conditions for the torsion load case

For all nodes in both the journal and crank pin fillet, principal stresses are extracted and the equivalent torsional stress is calculated:

$$\tau_{equiv} = \max\left(\frac{|\sigma_1 - \sigma_2|}{2}, \frac{|\sigma_2 - \sigma_3|}{2}, \frac{|\sigma_1 - \sigma_3|}{2}\right).$$

The maximum value taken for the subsequent calculation of the **SCF**:

$$\alpha_T = \tau_{equiv,\alpha} / \tau_N$$

$$\beta_T = \tau_{equiv,\beta} / \tau_N$$

where: τ_N is nominal torsional stress referred to the crankpin and journal, respectively, as specified in paragraph 2.2.2 of *Publication No. 8/P*, with the torsional torque T:

$$\tau_N = T / W_P.$$

3.2 Pure Bending (4-Point Bending)

The examined structure is loaded in pure bending. In the model, surface warp at the end faces is suppressed.

The bending moment is applied to the central node located at the crankshaft axis. This node acts as the master node with 6 degrees of freedom and is connected rigidly to all nodes of the end face.

Boundary and load conditions are valid for both in-line- and V-type engines.

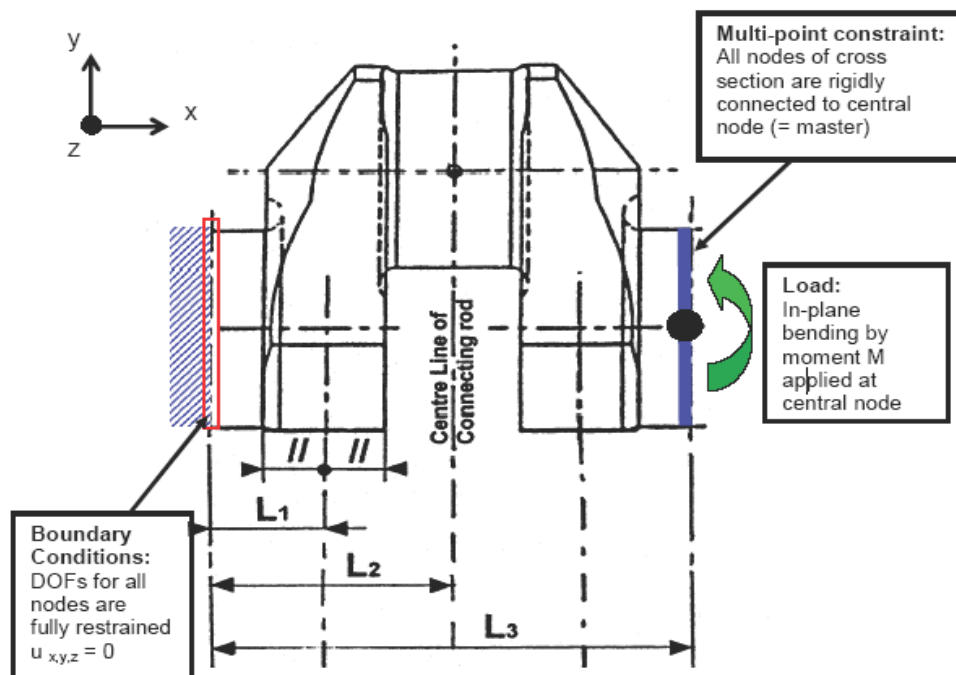

Fig. 3.2. Boundary and load conditions for the pure bending load case

For all nodes in both the journal and pin fillet, von Mises equivalent stresses σ_{equiv} are extracted. The maximum value is used to calculate the SCF according to:

$$\alpha_B = \sigma_{equiv,\alpha} / \sigma_N$$

$$\beta_B = \sigma_{equiv,\beta} / \sigma_N$$

Nominal stress σ_N is calculated as specified in paragraph 2.1.2.1 of *Publication 8/P* with the bending moment M :

$$\sigma_N = M / M_{equiv}$$

3.3 Bending with Shear Force (3-Point Bending)

This load case is calculated to determine the **SCF** for pure transverse force (radial force, β_0) for the journal fillet.

The structure is loaded in 3-point bending. In the model, surface warp at the both end faces is suppressed. All nodes are connected rigidly to the centre node; boundary conditions are applied to the centre nodes. These nodes act as master nodes with 6 degrees of freedom.

The force is applied to the central node located at the pin centre-line of the connecting rod.

This node is connected to all nodes of the pin cross-sectional area. Warping of the sectional area is not suppressed.

Boundary and load conditions are valid for both in-line and V-type engines. V-type engines can be modelled with one connecting rod force only. Using two connecting rod forces will make no significant change in the **SCF**.

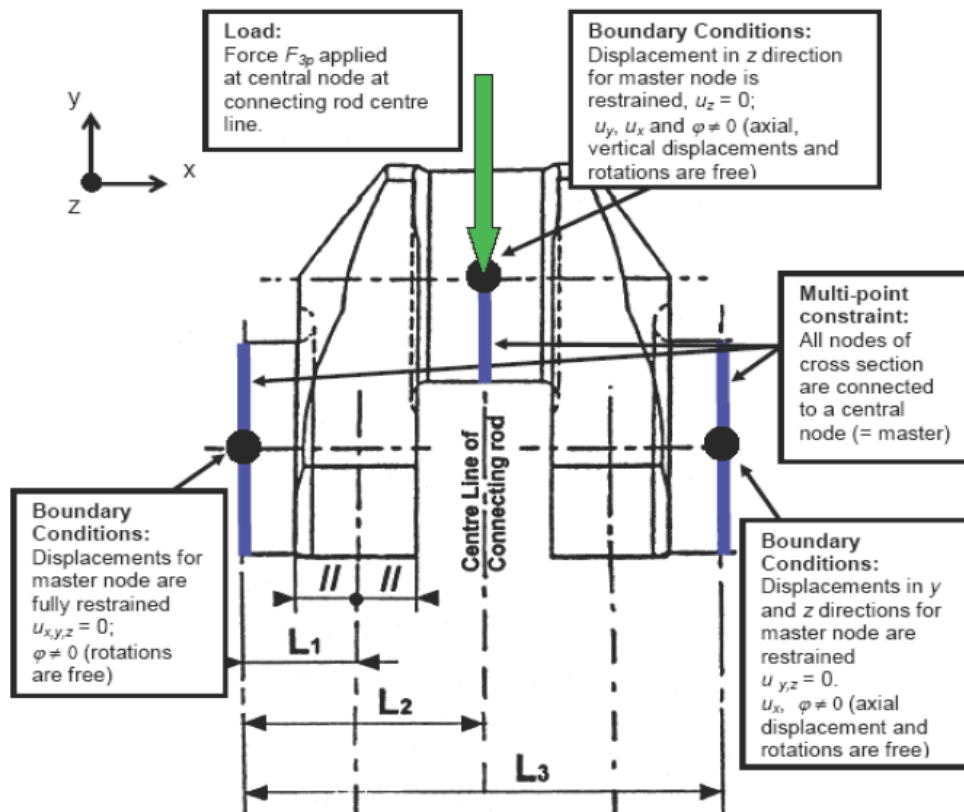

Fig. 3.3. Boundary and load conditions for the 3-point bending load case of an in-line engine

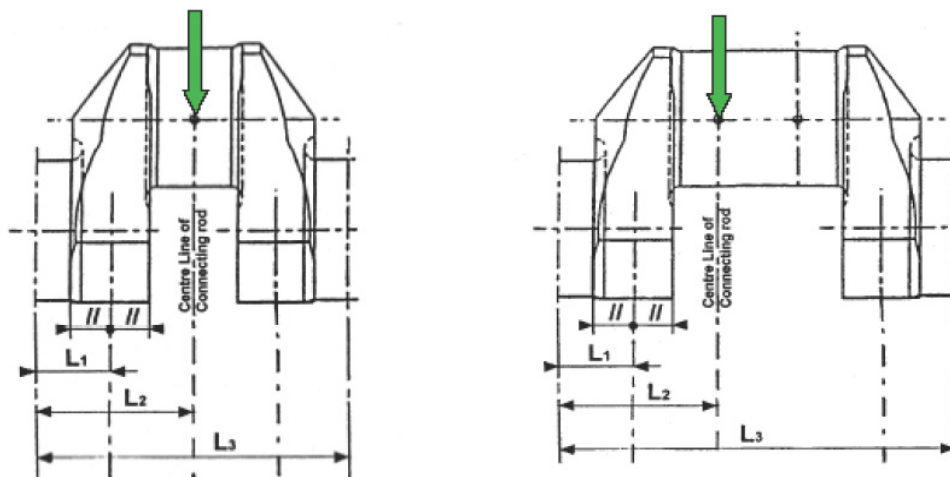

Fig. 3.4. Load applications for in-line and V-type engines

The maximum equivalent von Mises stress, σ_{3P} , in the journal fillet is evaluated. The **SCF** in the journal fillet can be determined in two ways as shown below.

3.3.1 Method 1

The results from 3-point and 4-point bending are combined as follows:

$$\sigma_{3P} = \sigma_{N3P} \cdot \beta_B + \sigma_{Q3P} \cdot \beta_B$$

where:

σ_{3P} as found by the FE calculation;

σ_{N3P} – nominal bending stress in the web centre due to the force F_{3P} [N] applied to the centre-line of the actual connecting rod, see Fig. 3.4;

β_B as determined in paragraph 3.2;

$\sigma_{Q3P} = Q_{3P} / (B \cdot W)$ where Q_{3P} is the radial (shear) force in the web due to the force F_{3P} [N] applied to the centre-line of the actual connecting rod, see also Fig. 2.1.1 in *Publication 8/P*.

3.3.2 Method 2

In a statically determined system with one crank throw supported by two bearings, the bending moment and radial (shear) force are proportional. Therefore, the journal fillet **SCF** can be found directly by the 3-point bending FE calculation.

The **SCF** is then calculated according to:

$$\beta_{BQ} = \frac{\sigma_{3P}}{\sigma_{N3P}}$$

For symbols, see paragraph 3.3.1.

When using this method, the radial force and stress determination in accordance with *Publication 8/P* becomes superfluous. The alternating bending stress in the journal fillet, as specified in paragraph 2.1.3 of *Publication 8/P*, is then evaluated:

$$|\sigma_{BG} = \pm| \beta_{BQ} \cdot \sigma_{BFN}$$

Note that the use of this method does not apply to the crankpin fillet and that this **SCF** must not be used in connection with calculation methods other than those assuming a statically determined system specified in *Publication 8/P*.

APPENDIX IV**Guidance for Evaluation of Fatigue Tests****Contents**

1 Introduction	29
1.1 Small Specimen Testing	29
1.2 Full-Size Crank Throw Testing	29
2 Evaluation of Test Results	30
2.1 Principles	30
2.2 Staircase Method	30
2.3 Modified Staircase Method	30
2.4 Calculation of Sample Mean and Standard Deviation	31
2.5 Confidence Interval for Mean Fatigue Limit	32
2.6 Confidence Interval for Standard Deviation	32
3 Small Specimen Testing	33
3.1 Determination of Bending Fatigue Strength	33
3.2 Determination of Torsional Fatigue Strength	34
3.3 Other Test Positions	34
3.4 Correlation of Test Results	34
4 Full Size Testing	35
4.1 Hydraulic Pulsation	35
4.2 Resonance Tester	35
4.3 Use of Results And Crankshaft Acceptability	36
5 Use of Existing Results For Similar Crankshafts	37

1 Introduction

Fatigue testing can be divided into two main groups; testing of small specimens and full-size crank throws. Testing can be made using the staircase method or a modified version thereof which is presented in this document. Other statistical evaluation methods may also be applied.

1.1 Small Specimen Testing

For crankshafts without any fillet surface treatment, the fatigue strength can be determined by testing small specimens taken from a full-size crank throw. When other areas in the vicinity of the fillets are surface treated introducing residual stresses in the fillets, this approach cannot be applied.

One advantage of this approach is the rather high number of specimens which can be then manufactured. Another advantage is that the tests can be made with different stress ratios (R -ratios) and/or different modes e.g. axial, bending and torsion, with or without a notch. This is required for evaluation of the material data to be used with critical plane criteria.

1.2 Full-Size Crank Throw Testing

For crankshafts with surface treatment the fatigue strength can only be determined through testing of full size crank throws. For cost reasons, this usually means a low number of crank throws. The load can be applied by hydraulic actuators in a 3- or 4-point bending arrangement, or by an exciter in a resonance test rig. The latter is frequently used, although it usually limits the stress ratio to $R = -1$.

2 Evaluation of Test Results

2.1 Principles

Prior to fatigue testing the crankshaft must be tested as required by quality control procedures, e.g. for chemical composition, mechanical properties, surface hardness, hardness depth and extension, fillet surface finish, etc.

The test samples should be prepared so as to represent the “lower end” of the acceptance range e.g. for induction hardened crankshafts this means the lower range of acceptable hardness depth, the shortest extension through a fillet, etc. Otherwise the mean value test results should be corrected with a confidence interval: a 90% confidence interval may be used both for the sample mean and the standard deviation.

The test results, when applied in M53, shall be evaluated to represent the mean fatigue strength, with or without taking into consideration the 90% confidence interval as mentioned above. The standard deviation should be considered by taking the 90% confidence into account. Subsequently the result to be used as the fatigue strength is then the mean fatigue strength minus one standard deviation.

If the evaluation aims to find a relationship between (static) mechanical properties and the fatigue strength, the relation must be based on the real (measured) mechanical properties, not on the specified minimum properties.

The calculation technique presented in Chapter 2.4 was developed for the original staircase method. However, since there is no similar method dedicated to the modified staircase method the same is applied for both.

2.2 Staircase Method

In the original staircase method, the first specimen is subjected to a stress corresponding to the expected average fatigue strength. If the specimen survives 10^7 cycles, it is discarded and the next specimen is subjected to a stress that is one increment above the previous, i.e. a survivor is always followed by the next using a stress one increment above the previous. The increment should be selected to correspond to the expected level of the standard deviation.

When a specimen fails prior to reaching 10^7 cycles, the obtained number of cycles is noted and the next specimen is subjected to a stress that is one increment below the previous. With this approach, the sum of failures and run-outs is equal to the number of specimens.

This original staircase method is only suitable when a high number of specimens are available. Through simulations it has been found that the use of about 25 specimens in a staircase test leads to a sufficient accuracy in the result.

2.3 Modified Staircase Method

When a limited number of specimens are available, it is advisable to apply the modified staircase method. Here the first specimen is subjected to a stress level that is most likely well below the average fatigue strength. When this specimen has survived 10^7 cycles, this same specimen is subjected to a stress level one increment above the previous. The increment should be selected to correspond to the expected level of the standard deviation. This is continued with the same specimen until failure.

Then the number of cycles is recorded and the next specimen is subjected to a stress that is at least 2 increments below the level where the previous specimen failed.

With this approach, the number of failures usually equals the number of specimens.

The number of run-outs, counted as the highest level where 10^7 cycles were reached, also equals the number of specimens.

The acquired result of a modified staircase method should be used with care, since some results available indicate that testing a runout on a higher test level, especially at high mean stresses, tends to increase the fatigue limit. However, this “training effect” is less pronounced for high strength steels (e.g. UTS > 800 MPa).

If the confidence calculation is desired or necessary, the minimum number of test specimens is 3.

2.4 Calculation of Sample Mean and Standard Deviation

A hypothetical example of tests for 5 crank throws is presented further in the subsequent text. When using the modified staircase method and the evaluation method of Dixon and Mood, the number of samples will be 10, meaning 5 run-outs and 5 failures, i.e.:

$$\text{Number of samples } n = 10$$

Furthermore, the method distinguishes between

$$\begin{aligned} \text{Less frequent event is failures } C = 1 \\ \text{Less frequent event is run-outs } C = 2 \end{aligned}$$

The method uses only the less frequent occurrence in the test results, i.e. if there are more failures than run-outs, then the number of run-outs is used, and vice versa.

In the modified staircase method, the number of run-outs and failures are usually equal. However, the testing can be unsuccessful, e.g. the number of run-outs can be less than the number of failures if a specimen with 2 increments below the previous failure level goes directly to failure. On the other hand, if this unexpected premature failure occurs after a rather high number of cycles, it is possible to define the level below this as a run-out.

Dixon and Mood’s approach, derived from the maximum likelihood theory, which also may be applied here, especially on tests with few samples, presented some simple approximate equations for calculating the sample mean and the standard deviation from the outcome of the staircase test. The sample mean can be calculated as follows:

$$\begin{aligned} \bar{S}_a &= S_{a0} + d \cdot \left(\frac{A}{F} - \frac{1}{2} \right) \text{ when } C = 1 \\ \bar{S}_a &= S_{a0} + d \cdot \left(\frac{A}{F} + \frac{1}{2} \right) \text{ when } C = 2 \end{aligned}$$

The standard deviation can be found by:

$$s = 1.62 \cdot d \cdot \left(\frac{F \cdot B - A^2}{F^2} + 0.029 \right)$$

where:

S_{a0} is the lowest stress level for the less frequent occurrence,

d is the stress increment

$$F = \sum f_i$$

$$A = \sum i \cdot f_i$$

$$B = \sum i^2 \cdot f_i$$

i is the stress level numbering,

f_i is the number of samples at stress level i .

The formula for the standard deviation is an approximation and can be used when:

$$\frac{B \cdot F - A^2}{F^2} > 0.3 \text{ and } 0.5 \cdot s < d < 1.5 \cdot s$$

If any of these two conditions are not fulfilled, a new staircase test should be considered or the standard deviation should be taken quite large in order to be on the safe side.

If increment d is greatly higher than the standard deviation s , the procedure leads to a lower standard deviation and a slightly higher sample mean, both compared to values calculated when the difference between the increment and the standard deviation is relatively small. Respectively, if increment d is much less than the standard deviation s , the procedure leads to a higher standard deviation and a slightly lower sample mean.

2.5 Confidence Interval for Mean Fatigue Limit

If the staircase fatigue test is repeated, the sample mean and the standard deviation will most likely be different from the previous test. Therefore, it is necessary to assure with a given confidence that the repeated test values will be above the chosen fatigue limit by using a confidence interval for the sample mean.

The confidence interval for the sample mean value with unknown variance is known to be distributed according to the t -distribution (also called *student's t-distribution*) which is a distribution symmetric around the average.

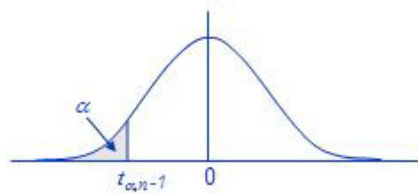

Figure 2.1. Student's t -distribution

The confidence level normally used for the sample mean is 90 %, meaning that 90 % of sample means from repeated tests will be above the value calculated with the chosen confidence level. The figure shows the t -value for $(1 - \alpha) \cdot 100\%$ confidence interval for the sample mean.

If S_a is the empirical mean and s is the empirical standard deviation over a series of n samples, in which the variable values are normally distributed with an unknown sample mean and unknown variance, the $(1 - \alpha) \cdot 100\%$ confidence interval for the mean is:

$$P\left(S_a - t_{\alpha, n-1} \cdot \frac{s}{\sqrt{n}} < S_{ax\%}\right) = 1 - \alpha$$

The resulting confidence interval is symmetric around the empirical mean of the sample values, and the lower endpoint can be found as:

$$S_{ax\%} = S_a - t_{\alpha, n-1} \cdot \frac{s}{\sqrt{n}}$$

which is the mean fatigue limit (population value) to be used to obtain the reduced fatigue limit where the limits for the probability of failure are taken into consideration.

2.6 Confidence Interval for Standard Deviation

The confidence interval for the variance of a normal random variable is known to possess a chi-square distribution with $n - 1$ degrees of freedom.

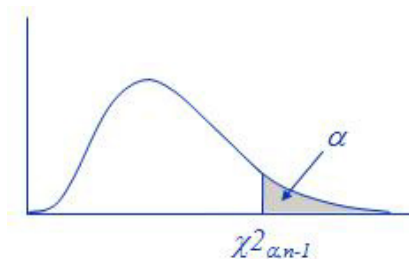

Figure 2.2. Chi-square distribution

The confidence level on the standard deviation is used to ensure that the standard deviations for repeated tests are below an upper limit obtained from the fatigue test standard deviation with a confidence level. The figure shows the chi-square for $(1 - \alpha) \cdot 100\%$ confidence interval for the variance.

An assumed fatigue test value from n samples is a normal random variable with a variance of σ^2 and has an empirical variance s^2 . Then a $(1 - \alpha) \cdot 100\%$ confidence interval for the variance is:

$$P\left(\frac{(n-1)s^2}{\sigma^2} < \chi_{\alpha, n-1}^2\right) = 1 - \alpha$$

A $(1 - \alpha) \cdot 100\%$ confidence interval for the standard deviation is obtained by the square root of the upper limit of the confidence interval for the variance and can be found by:

$$S_{\chi\%} = \sqrt{\frac{n-1}{\chi_{\alpha, n-1}^2}} \cdot S$$

This standard deviation (population value) is to be used to obtain the fatigue limit, where the limits for the probability of failure are taken into consideration.

3 Small Specimen Testing

In this connection, a small specimen is considered to be one of the specimens taken from a crank throw. Since the specimens shall be representative for the fillet fatigue strength, they should be taken out close to the fillets, as shown in Figure 3.1.

It should be made certain that the principal stress direction in the specimen testing is equivalent to the full-size crank throw. The verification is recommended to be done by utilising the finite element method.

The (static) mechanical properties are to be determined as stipulated by the quality control procedures.

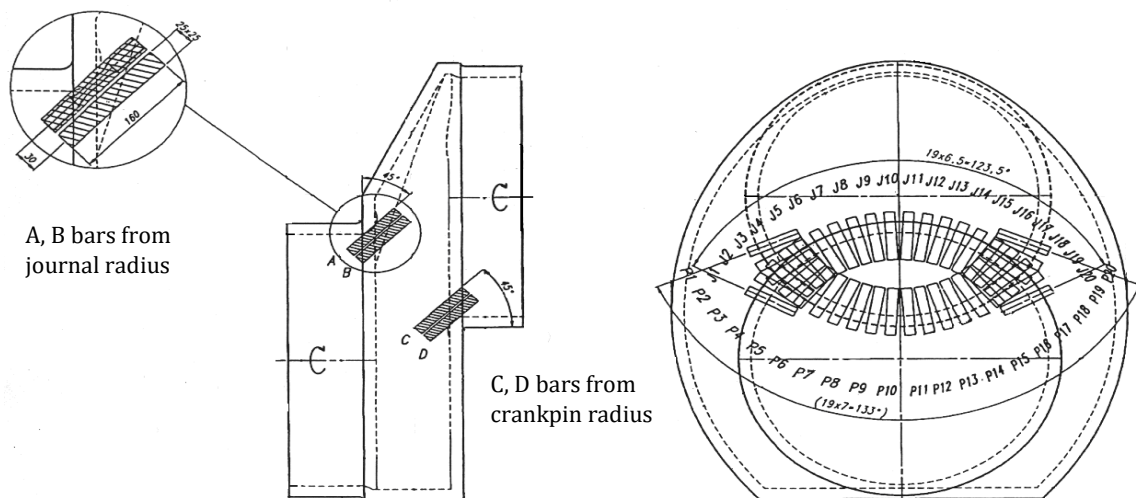

Figure 3.1. Specimen locations in a crank throw

3.1 Determination of Bending Fatigue Strength

It is advisable to use un-notched specimens in order to avoid uncertainties related to the stress gradient influence. Push-pull testing method (stress ratio $R = -1$) is preferred, but especially for the purpose of critical plane criteria other stress ratios and methods may be added.

In order to ensure principal stress direction in push-pull testing to represent the full-size crank throw principal stress direction and when no further information is available, the specimen shall be taken in 45 degrees angle as shown in Figure 3.1.

- A. If the objective of the testing is to document the influence of high cleanliness, test samples taken from positions approximately 120 degrees in a circumferential direction may be used. See Figure 3.1.
- B. If the objective of the testing is to document the influence of **continuous grain flow (cgf)** forging, the specimens should be restricted to the vicinity of the crank plane.

3.2 Determination of Torsional Fatigue Strength

- A. If the specimens are subjected to torsional testing, the selection of samples should follow the same guidelines as for bending above. The stress gradient influence has to be considered in the evaluation.
- B. If the specimens are tested in push-pull and no further information is available, the samples should be taken out at an angle of 45 degrees to the crank plane in order to ensure collinearity of the principal stress direction between the specimen and the full-size crank throw. When taking the specimen at a distance from the (crank) middle plane of the crankshaft along the fillet, this plane rotates around the pin centre point making it possible to resample the fracture direction due to torsion (the results are to be converted into the pertinent torsional values).

3.3 Other Test Positions

If the test purpose is to find fatigue properties and the crankshaft is forged in a manner likely to lead to **cgf**, the specimens may also be taken longitudinally from a prolonged shaft piece where specimens for mechanical testing are usually taken. The condition is that this prolonged shaft piece is heat treated as a part of the crankshaft and that the size is so as to result in a similar quenching rate as the crank throw.

When using test results from a prolonged shaft piece, it must be considered how well the grain flow in that shaft piece is representative for the crank fillets.

3.4 Correlation of Test Results

The fatigue strength achieved by specimen testing shall be converted to correspond to the full-size crankshaft fatigue strength with an appropriate method (size effect).

When using the bending fatigue properties from tests mentioned in this section, it should be kept in mind that successful **continuous grain flow (cgf)** forging leading to elevated values compared to other (non **cgf**) forging, will normally not lead to a torsional fatigue strength improvement of the same magnitude.

In such cases it is advised to either carry out also torsional testing or to make a conservative assessment of the torsional fatigue strength, e.g. by using no credit for **cgf**. This approach is applicable when using the Gough Pollard criterion. However, this approach is not recognised when using the von Mises or a multi-axial criterion such as Findley.

If the found ratio between bending and torsion fatigue differs significantly from $\sqrt{3}$, one should consider replacing the use of the von Mises criterion with the Gough Pollard criterion. Also, if critical plane criteria are used, it must be kept in mind that **cgf** makes the material inhomogeneous in terms of fatigue strength, meaning that the material parameters differ with the directions of the planes.

Any addition of influence factors must be made with caution. If for example a certain addition for clean steel is documented, it may not necessarily be fully combined with a *K*-factor for **cgf**. Direct testing of samples from a clean and **cgf** forged crank is preferred.

4 Full Size Testing

4.1 Hydraulic Pulsation

A hydraulic test rig can be arranged for testing a crankshaft in 3-point or 4-point bending as well as in torsion. This allows for testing with any R -ratio.

Although the applied load should be verified by strain gauge measurements on plain shaft sections for the initiation of the test, it is not necessarily used during the test for controlling load. It is also pertinent to check fillet stresses with strain gauge chains.

Furthermore, it is important that the test rig provides boundary conditions as defined in Appendix III (section 3.1 to 3.3).

The (static) mechanical properties are to be determined as stipulated by the quality control procedures.

4.2 Resonance Tester

A rig for bending fatigue normally works with an R -ratio of -1 . Due to operation close to resonance, the energy consumption is moderate. Moreover, the frequency is usually relatively high, meaning that 10^7 cycles can be reached within some days. Figure 4.1 shows a layout of the testing arrangement.

The applied load should be verified by strain gauge measurements on plain shaft sections. It is also pertinent to check fillet stresses with strain gauge chains.

Clamping around the journals must be arranged in a way that prevents severe fretting which could lead to a failure under the edges of the clamps. If some distance between the clamps and the journal fillets is provided, the loading is consistent with 4-point bending and thus representative for the journal fillets also.

In an engine, the crankpin fillets normally operate with an R -ratio slightly above -1 and the journal fillets slightly below -1 . If found necessary, it is possible to introduce a mean load (deviate from $R = -1$) by means of a spring preload.

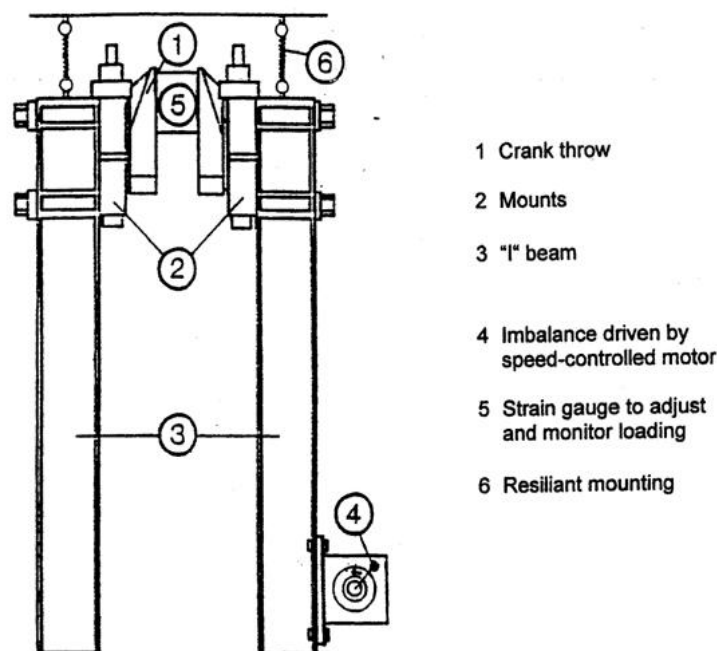

Figure 4.1. An example of testing arrangement of the resonance tester for bending loading

A rig for torsion fatigue can also be arranged as shown in Figure 4.2. When a crank throw is subjected to torsion, the twist of the crankpin makes the journals move sideways. If one single crank throw is tested in a torsion resonance test rig, the journals with their clamped-on weights will vibrate heavily sideways.

This sideway movement of the clamped-on weights can be reduced by having two crank throws, especially if the cranks are almost in the same direction. However, the journal in the middle will move more.

Since sideway movements can cause some bending stresses, the plain portions of the crankpins should also be provided with strain gauges arranged to measure any possible bending that could have an influence on the test results.

Similarly, to the bending case the applied load shall be verified by strain gauge measurements on plain shaft sections. It is also pertinent to check fillet stresses with strain gauge chains as well.

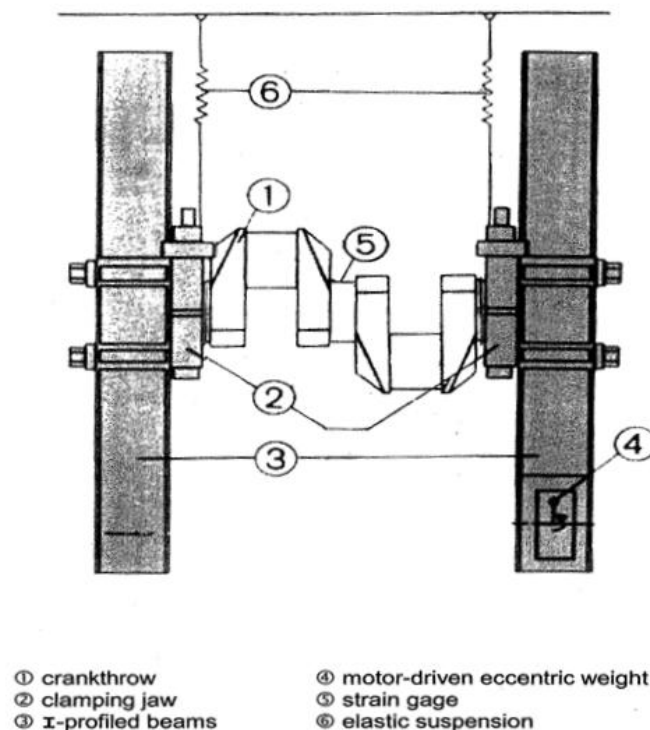

Figure 4.2. An example of testing arrangement of the resonance tester for torsion loading with double crank throw section

4.3 Use of Results And Crankshaft Acceptability

In order to combine tested bending and torsion fatigue strength results in calculation of crankshaft acceptability, see M53.7, the Gough-Pollard approach and the maximum principal equivalent stress formulation can be applied for the following cases:

At the crankpin fillet:

$$Q = \left(\sqrt{\left(\frac{\sigma_{BH} + \sigma_{add}}{\sigma_{DWCT}} \right)^2 + \left(\frac{\tau_H}{\tau_{DWCT}} \right)^2} \right)^{-1}$$

where:

σ_{DWCT} – fatigue strength by bending testing

τ_{DWCT} – fatigue strength by torsion testing.

for other parameters see subchapters 2.1.3, 2.2.3 and 4

Related to crankpin oil bore:

$$Q = \frac{\sigma_{DWOT}}{\sigma_v} ; \quad \sigma_v = \frac{1}{3} \cdot \sigma_{BO} \cdot \left[1 + 2 \cdot \sqrt{1 + \frac{9}{4} \cdot \left(\frac{\sigma_{TO}}{\sigma_{BO}} \right)^2} \right]$$

where:

σ_{DWOT} – fatigue strength by means of largest principal stress from torsion testing,

σ_v – equivalent alternating stress for the crankpin fillet and journal fillet, determined in accordance with paragraph 5 [MPa].

At the journal fillet:

$$Q = \left(\sqrt{\left(\frac{\sigma_{BG} + \sigma_{add}}{\sigma_{DWJT}} \right)^2 + \left(\frac{\tau_G}{\tau_{DWJT}} \right)^2} \right)^{-1}$$

where:

σ_{DWJT} – fatigue strength by bending testing

τ_{DWJT} – fatigue strength by torsion testing.

for other parameters see subchapters 2.1.3, 2.2.3 and 4

In case increase in fatigue strength due to the surface treatment is considered to be similar between the above cases, it is sufficient to test only the most critical location according to the calculation where the surface treatment had not been taken into account.

5 Use of Existing Results for Similar Crankshafts

For fillets or oil bores without surface treatment, the fatigue properties found by testing may be used for similar crankshaft designs providing:

- **Material:**
 - Similar material type.
 - Cleanliness on the same or better level.
 - The same mechanical properties can be granted (size versus hardenability).
- **Geometry:**
 - Difference in the size effect of stress gradient is insignificant or it is considered.
 - Principal stress direction is equivalent. See Chapter 3.
- **Manufacturing:**
 - Similar manufacturing process.

Induction hardened or gas nitrited crankshafts will suffer fatigue either at the surface or at the transition to the core. The surface fatigue strength as determined by fatigue tests of full size cranks, may be used on an equal or similar design as the tested crankshaft when the fatigue initiation occurred at the surface. With the similar design, it is meant that a similar material type and surface hardness are used and the fillet radius and hardening depth are within approximately $\pm 30\%$ of the tested crankshaft.

Fatigue initiation in the transition zone can be either subsurface, i.e. below the hard layer, or at the surface where the hardening ends. The fatigue strength at the transition to the core can be determined by fatigue tests as described above, provided that the fatigue initiation occurred at the transition to the core. Tests made with the core material only will not be representative since the tension residual stresses at the transition are lacking.

It has to be noted also what some recent research has shown: The fatigue limit can decrease in the very high cycle domain with subsurface crack initiation due to trapped hydrogen that accumulates through diffusion around some internal defect functioning as an initiation point. In these cases, it would be appropriate to reduce the fatigue limit by some percent per decade of cycles beyond 10^7 . Based on a publication by Yukitaka Murakami "Metal Fatigue: Effects of Small Defects and Non-metallic Inclusions" the reduction is suggested to be 5 % per decade especially when the hydrogen content is considered to be high.

APPENDIX V**Guidance For Calculation of Surface Treated Fillets and Oil Bore Outlets****Contents**

1 Introduction	39
2 Definition of Surface Treatment	39
2.1 Surface Treatment Methods	39
3 Calculation Principles	40
3.1 Evaluation of Local Fillet Stresses	41
3.2 Evaluation of Oil Bore Stresses	42
3.3 Acceptability Criteria	43
4 Induction Hardening	43
4.1 Local Fatigue Strength	45
5 Nitriding	46
5.1 Local Fatigue Strength	46
6 Cold Forming	47
6.1 Stroke Peening by Means of a Ball	47
6.1.1 Use of Existing Results for Similar Crankshafts	49
6.2 Cold Rolling	49
6.2.1 Use of Existing Results for Similar Crankshafts	49

1 Introduction

This appendix deals with surface treated fillets and oil bore outlets. The various treatments are explained and some empirical formulae are given for calculation purposes. Conservative empiricism has been applied intentionally, in order to be on the safe side from a calculation standpoint.

Please note that measurements or more specific knowledge should be used if available. However, in the case of a wide scatter (e.g. for residual stresses) the values should be chosen from the end of the range that would be on the safe side for calculation purposes.

2 Definition Of Surface Treatment

'Surface treatment' is a term covering treatments such as thermal, chemical or mechanical operations, leading to inhomogeneous material properties – such as hardness, chemistry or residual stresses – from the surface to the core.

2.1 Surface Treatment Methods

The following list covers possible treatment methods and how they influence the properties that are decisive for the fatigue strength.

Table 2.1.
Surface treatment methods and the characteristics they affect

Treatment method	Affecting
Induction hardening	Hardness and residual stresses
Nitriding	Chemistry, hardness and residual stresses
Case hardening	Chemistry, hardness and residual stresses
Die quenching (no temper)	Hardness and residual stresses
Cold rolling	Residual stresses

Treatment method	Affecting
Stroke peening	Residual stresses
Shot peening	Residual stresses
Laser peening	Residual stresses
Ball coining	Residual stresses

It is important to note that since only induction hardening, nitriding, cold rolling and stroke peening are considered relevant for marine engines, other methods as well as combination of two or more of the above are not dealt with in this document. In addition, die quenching can be considered in the same way as induction hardening.

3 Calculation Principles

The basic principle is that the alternating working stresses shall be below the local fatigue strength (including the effect of surface treatment) wherein non-propagating cracks may occur, see also section 6.1 for details. This is then divided by a certain safety factor. This applies through the entire fillet or oil bore contour as well as below the surface to a depth below the treatment-affected zone – i.e. to cover the depth all the way to the core.

Consideration of the local fatigue strength shall include the influence of the local hardness, residual stress and mean working stress. The influence of the ‘giga-cycle effect’, especially for initiation of subsurface cracks, should be covered by the choice of safety margin.

It is of vital importance that the extension of hardening/peening in an area with concentrated stresses be duly considered. Any transition where the hardening/peening is ended is likely to have considerable tensile residual stresses. This forms a ‘weak spot’ and is important if it coincides with an area of high stresses.

Alternating and mean working stresses must be known for the entire area of the stress concentration as well as to a depth of about 1.2 times the depth of the treatment. The following figure indicates this principle in the case of induction hardening. The base axis is either the depth (perpendicular to the surface) or along the fillet contour.

The acceptability criterion should be applied stepwise from the surface to the core as well as from the point of maximum stress concentration along the fillet surface contour to the web.

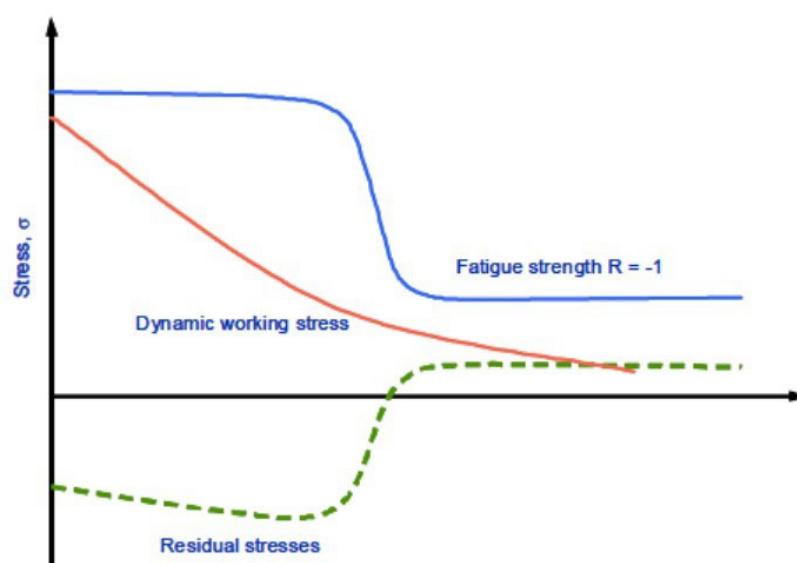

Figure 3.1. Stresses as functions of depth, general principles

3.1 Evaluation of Local Fillet Stresses

It is necessary to have knowledge of the stresses along the fillet contour as well as in the subsurface to a depth somewhat beyond the hardened layer. Normally this will be found via FEA as described in Appendix III. However, the element size in the subsurface range will have to be the same size as at the surface. For crankpin hardening only the small element size will have to be continued along the surface to the hard layer.

If no FEA is available, a simplified approach may be used. This can be based on the empirically determined stress concentration factors (SCFs), as in IACS UR M53.3 if within its validity range, and a relative stress gradient inversely proportional to the fillet radius.

Bending and torsional stresses must be addressed separately. The combination of these is addressed by the acceptability criterion.

The subsurface transition-zone stresses, with the minimum hardening depth, can be determined by means of local stress concentration factors along an axis perpendicular to the fillet surface. These functions $\alpha_{B-local}$ and $\alpha_{T-local}$ have different shapes due to the different stress gradients.

The SCFs α_B and α_T are valid at the surface. The local $\alpha_{B-local}$ and $\alpha_{T-local}$ drop with increasing depth. The relative stress gradients at the surface depend on the kind of stress raiser, but for crankpin fillets they can be simplified to $2/R_H$ in bending and $1/R_H$ in torsion. The journal fillets are handled analogously by using R_G and D_G . The nominal stresses are assumed to be linear from the surface to a midpoint in the web between the crankpin fillet and the journal fillet for bending and to the crankpin or journal centre for torsion.

The local SCFs are then functions of depth t according to Equation 3.1 as shown in Figure 3.2 for bending and respectively for torsion in Equation 3.2 and Figure 3.3.

$$\alpha_{B-local} = (\alpha_B - 1) \cdot e^{\frac{-2 \cdot t}{R_H}} + 1 - \left(\frac{2 \cdot t}{\sqrt{W^2 + S^2}} \right)^{\frac{0.6}{\alpha_B}} \quad (3.1)$$

$$\alpha_{T-local} = (\alpha_T - 1) \cdot e^{\frac{-t}{R_H}} + 1 - \left(\frac{2 \cdot t}{D} \right)^{\frac{1}{\alpha_T}} \quad (3.2)$$

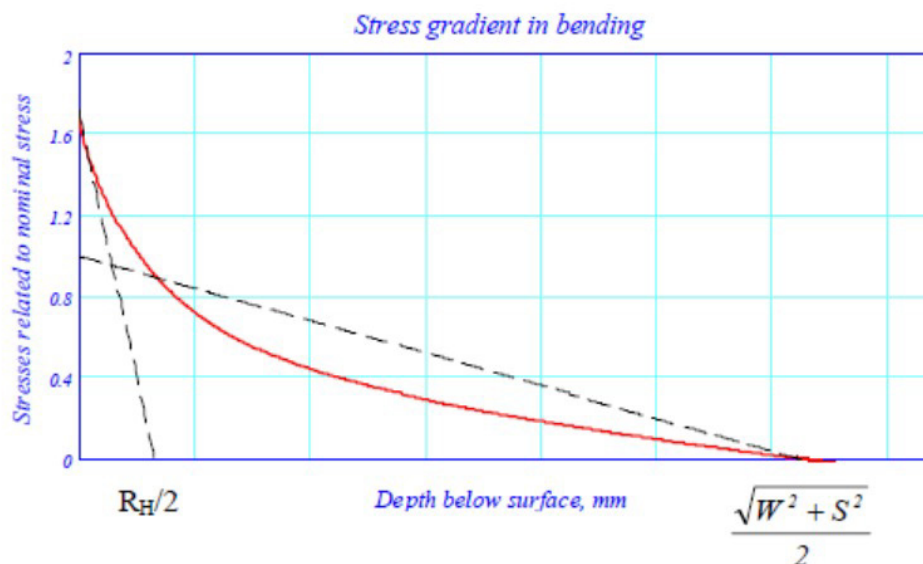

Figure 3.2.

Bending SCF in the crankpin fillet as a function of depth. The corresponding SCF for the journal fillet can be found by replacing R_H with R_G



Figure 3.3.
 Torsional SCF in the crankpin fillet as a function of depth. The corresponding SCF for the journal fillet can be found by replacing R_H with R_G and D with D_G

If the pin is hardened only and the end of the hardened zone is closer to the fillet than three times the maximum hardness depth, FEA should be used to determine the actual stresses in the transition zone.

3.2 Evaluation of Oil Bore Stresses

Stresses in the oil bores can be determined also by FEA. The element size should be less than $1/8$ of the oil bore diameter D_o and the element mesh quality criteria should be followed as prescribed in Appendix III. The fine element mesh should continue well beyond a radial depth corresponding to the hardening depth.

The loads to be applied in the FEA are the torque – see Appendix III item 3.1 – and the bending moment, with four-point bending as in Appendix III item 3.2.

If no FEA is available, a simplified approach may be used. This can be based on the empirically determined SCF from IACS UR M53.3 if within its applicability range. Bending and torsional stresses at the point of peak stresses are combined as in IACS UR M53.5.

Figure 3.4 indicates a local drop of the hardness in the transition zone between a hard and soft material. Whether this drop occurs depends also on the tempering temperature after quenching in the QT process.

The peak stress in the bore occurs at the end of the edge rounding. Within this zone the stress drops almost linearly to the centre of the pin. As can be seen from Figure 3.4, for shallow (A) and intermediate (B) hardening, the transition point practically coincides with the point of maximal stresses. For deep hardening the transition point comes outside of the point of peak stress and the local stress can be assessed as a portion $(1 - 2tH/D)$ of the peak stresses where tH is the hardening depth.

The subsurface transition-zone stresses (using the minimum hardening depth) can be determined by means of local stress concentration factors along an axis perpendicular to the oil bore surface. These functions $\gamma_{B-local}$ and $\gamma_{T-local}$ have different shapes, because of the different stress gradients.

The stress concentration factors γ_B and γ_T are valid at the surface. The local SCFs $\gamma_{B-local}$ and $\gamma_{T-local}$ drop with increasing depth. The relative stress gradients at the surface depend on the kind of stress raiser, but for crankpin oil bores they can be simplified to $4/D_o$ in bending and $2/D_o$ in torsion. The local SCFs are then functions of the depth t :

$$\gamma_{B-local} = (\gamma_B - 1) \cdot e^{\frac{-4 \cdot t}{D_o}} + 1 \quad (3.3)$$

$$\gamma_{T-local} = (\gamma_T - 1) \cdot e^{\frac{-2 \cdot t}{D_o}} + 1 \quad (3.4)$$

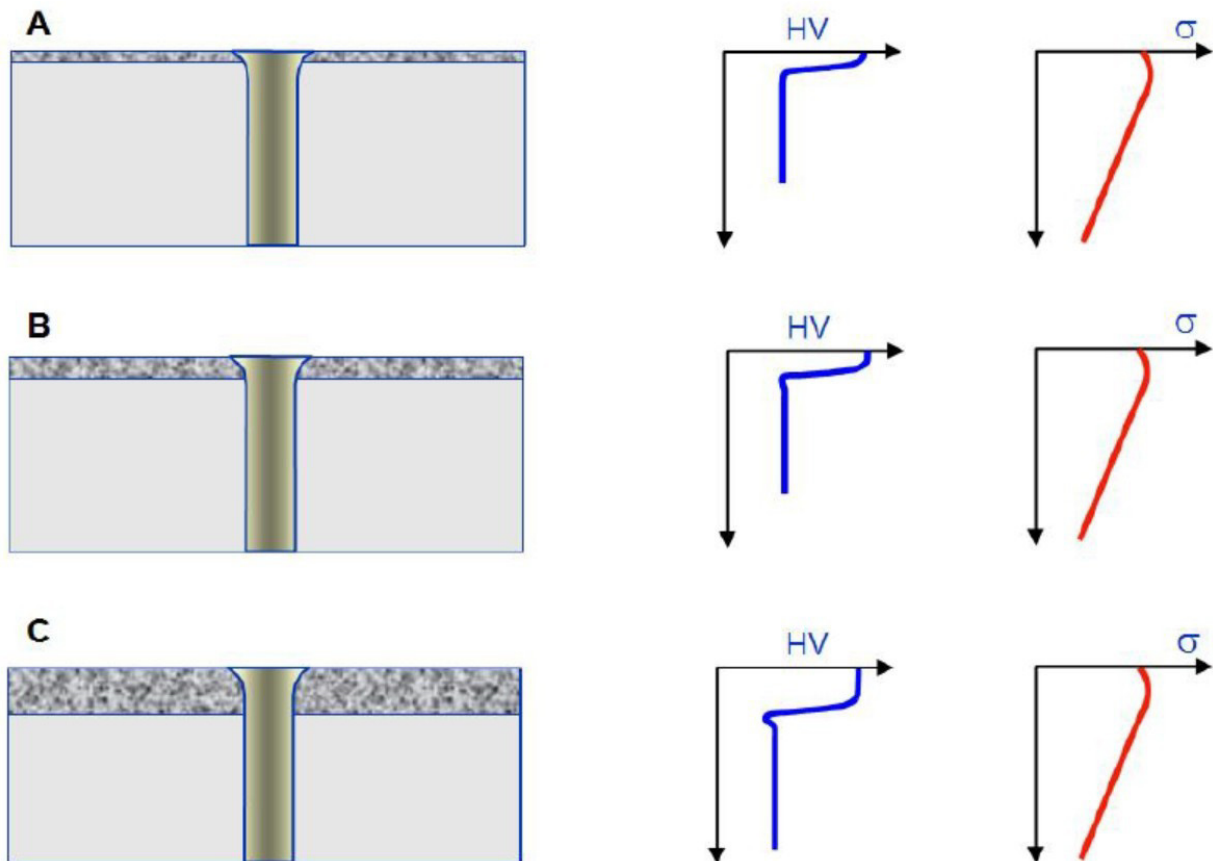

Figure 3.4. Stresses and hardness in induction hardened oil holes

3.3 Acceptability Criteria

Acceptance of crankshafts is based on fatigue considerations; M53 compares the equivalent alternating stress and the fatigue strength ratio to an acceptability factor of $Q \geq 1.15$ for oil bore outlets, crankpin fillets and journal fillets. This shall be extended to cover also surface treated areas independent of whether surface or transition zone is examined.

4 Induction Hardening

Generally, the hardness specification shall specify the surface hardness range i.e. minimum and maximum values, the minimum and maximum extension in or through the fillet and also the minimum and maximum depth along the fillet contour. The referenced Vickers hardness is considered to be **HV0.5...HV5**.

The induction hardening depth is defined as the depth where the hardness is 80% of the minimum specified surface hardness.

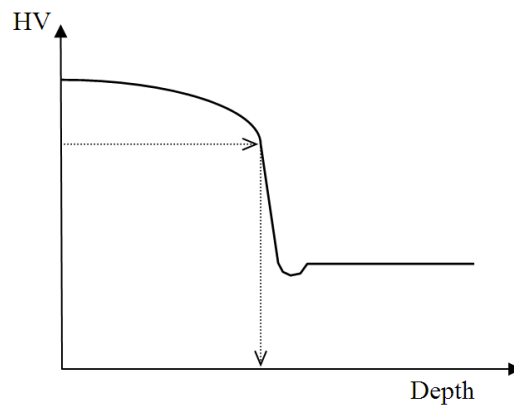

Figure 4.1.

Typical hardness as a function of depth. The arrows indicate the defined hardening depth. Note the indicated potential hardness drop at the transition to the core. This can be a weak point as local strength may be reduced and tensile residual stresses may occur.

In the case of crankpin or journal hardening only, the minimum distance to the fillet shall be specified due to the tensile stress at the heat-affected zone as shown in Figure 4.2.

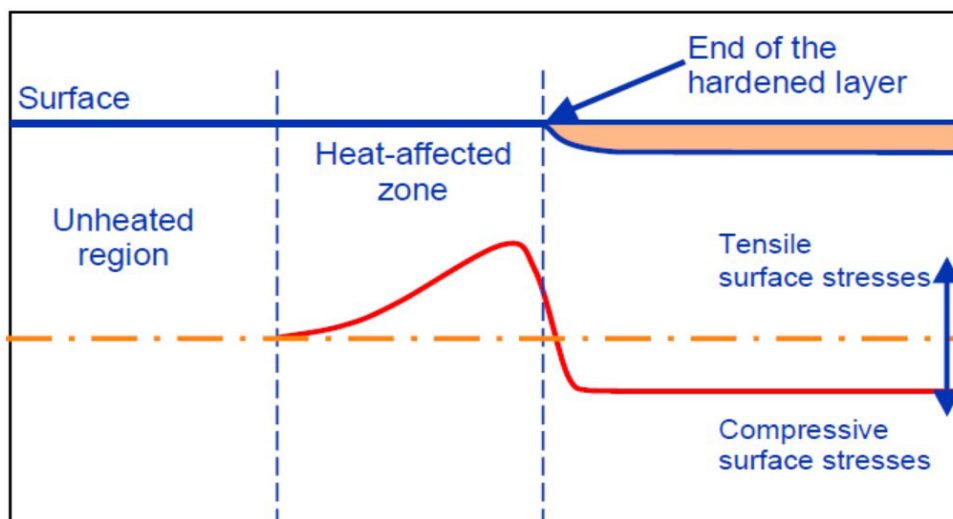

Figure 4.2. Residual stresses along the surface of a pin and fillet

If the hardness-versus-depth profile and residual stresses are not known or specified, one may assume the following:

- the hardness profile consists of two layers (see figure 4.1):
 - constant hardness from the surface to the transition zone,
 - constant hardness from the transition zone to the core material;
- residual stresses in the hard zone of 200 MPa (compression);
- transition-zone hardness as 90% of the core hardness unless the local hardness drop is avoided;
- transition-zone maximum residual stresses (von Mises) of 300 MPa tension.

If the crankpin or journal hardening ends close to the fillet, the influence of tensile residual stresses has to be considered. If the minimum distance between the end of the hardening and the beginning of the fillet is more than 3 times the maximum hardening depth, the influence may be disregarded.

4.1 Local Fatigue Strength

Induction-hardened crankshafts will suffer fatigue either at the surface or at the transition to the core. The fatigue strengths, for both the surface and the transition zone, can be determined by fatigue testing of full size cranks as described in Appendix IV. In the case of a transition zone, the initiation of the fatigue can be either subsurface (i.e. below the hard layer) or at the surface where the hardening ends.

Tests made with the core material only will not be representative since the tensile residual stresses at the transition are lacking.

Alternatively, the surface fatigue strength can be determined empirically as follows where HV is the surface Vickers hardness. The Equation 4.1 provides a conservative value, with which the fatigue strength is assumed to include the influence of the residual stress. The resulting value is valid for a working stress ratio of $R = -1$:

$$\sigma_{F \text{ surface}} = 400 + 0.5 \cdot (HV - 400) \text{ [MPa]} \quad (4.1)$$

It has to be noted also that the mean stress influence of induction-hardened steels may be significantly higher than that for QT steels.

The fatigue strength in the transition zone, without taking into account any possible local hardness drop, shall be determined by the equation introduced in UR M53.6.

For journal and respectively to crankpin fillet applies:

$$\sigma_{F \text{ transition, c pin}} = \pm K \cdot (0.42 \cdot \sigma_B + 39.3) \cdot \left[0.264 + 1.073 \cdot Y^{-0.2} + \frac{785 - \sigma_B}{4900} + \frac{196}{\sigma_B} \cdot \sqrt{\frac{1}{X}} \right] \quad (4.2)$$

where:

$Y = D_G$ and $X = R_G$ for journal fillet

$Y = D$ and $X = R_H$ for crankpin fillet

$Y = D$ and $X = D_o/2$ for oil bore outlet.

The influence of the residual stress is not included in 4.2.

For the purpose of considering subsurface fatigue, below the hard layer, the disadvantage of tensile residual stresses has to be considered by subtracting 20% from the value determined above. This 20% is based on the mean stress influence of alloyed quenched and tempered steel having a residual tensile stress of 300 MPa.

When the residual stresses are known to be lower, also smaller value of subtraction shall be used. For low-strength steels the percentage chosen should be higher.

For the purpose of considering surface fatigue near the end of the hardened zone – i.e. in the heat-affected zone shown in the Figure 4.2 – the influence of the tensile residual stresses can be considered by subtracting a certain percentage, in accordance with Table 4.1, from the value determined by the above formula.

Table 4.1
The influence of tensile residual stresses at a given distance
from the end of the hardening towards the fillet

I.	0 to 1.0 of the max. hardening depth:	20%
II.	1.0 to 2.0 of the max. hardening depth:	12%
III.	2.0 to 3.0 of the max. hardening depth:	6%
IV.	3.0 or more of the max. hardening depth:	0%

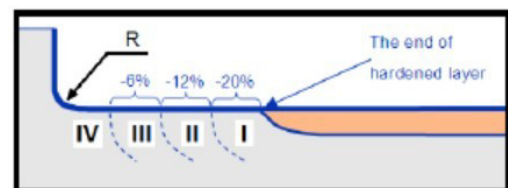

5 Nitriding

The hardness specification shall include the surface hardness range (min and max) and the minimum and maximum depth. Only gas nitriding is considered. The referenced Vickers hardness is considered to be **HV0.5**.

The depth of the hardening is defined in different ways in the various standards and the literature. The most practical method to use in this context is to define the nitriding depth t_N as the depth to a hardness of 50 HV above the core hardness.

The hardening profile should be specified all the way to the core. If this is not known, it may be determined empirically via the following formula:

$$HV(t) = HV_{core} + (HV_{surface} - HV_{core}) \cdot \left(\frac{50}{HV_{surface} - HV_{core}} \right)^{\left(\frac{t}{t_N} \right)^2} \quad (5.1)$$

where:

- t = the local depth,
- $HV(t)$ = hardness at depth t ,
- HV_{core} = core hardness (minimum),
- $HV_{surface}$ = surface hardness (minimum),
- t_N = nitriding depth as defined above (minimum).

5.1 Local Fatigue Strength

It is important to note that in nitrided crankshaft cases, fatigue is found either at the surface or at the transition to the core. This means that the fatigue strength can be determined by tests as described in Appendix IV.

Alternatively, the surface fatigue strength (principal stress) can be determined empirically and conservatively as follows. This is valid for a surface hardness of 600 HV or greater:

$$\sigma_{F_{surface}} = 450 \text{ [MPa]} \quad (5.2)$$

Note that this fatigue strength is assumed to include the influence of the surface residual stress and applies for a working stress ratio of $R = -1$.

The fatigue strength in the transition zone can be determined by the equation introduced in UR M53.6. For crankpin and respectively to journal applies:

$$\sigma_{F_{transition,c\ pin}} = \pm K \cdot (0.42 \cdot \sigma_B + 39.3) \cdot \left[0.264 + 1.073 \cdot Y^{-0.2} + \frac{785 - \sigma_B}{4900} + \frac{196}{\sigma_B} \cdot \sqrt{\frac{1}{X}} \right] \quad (5.3)$$

where:

- $Y = D_G$ and $X = R_G$ for journal fillet,
- $Y = D$ and $X = R_H$ for crankpin fillet,
- $Y = D$ and $X = D_o/2$ for oil bore outlet.

Note that this fatigue strength is not assumed to include the influence of the residual stresses.

In contrast to induction-hardening the nitrided components have no such distinct transition to the core. Although the compressive residual stresses at the surface are high, the balancing tensile stresses in the core are moderate because of the shallow depth. For the purpose of analysis of subsurface fatigue the disadvantage of tensile residual stresses in and below the transition zone may be even disregarded in view of this smooth contour of a nitriding hardness profile.

Although in principle the calculation should be carried out along the entire hardness profile, it can be limited to a simplified approach of examining the surface and an artificial transition point. This artificial transition point can be taken at the depth where the local hardness is approximately

20 HV above the core hardness. In such a case, the properties of the core material should be used. This means that the stresses at the transition to the core can be found by using the local SCF formulae mentioned earlier when inserting $t = 1.2t_N$.

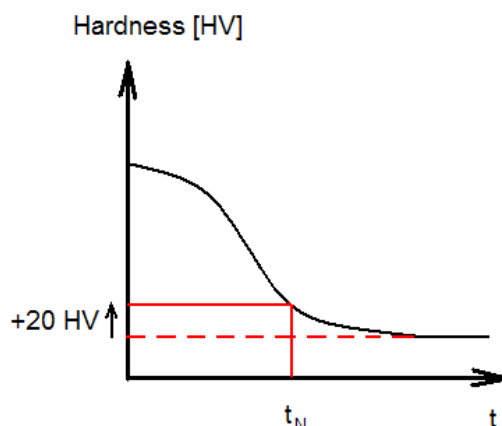

Figure 5.1. Sketch of the location for the artificial transition point in the depth direction

6 Cold Forming

The advantage of stroke peening or cold rolling of fillets is the compressive residual stresses introduced in the high-loaded area. Even though surface residual stresses can be determined by X-ray diffraction technique and subsurface residual stresses can be determined through neutron diffraction, the local fatigue strength is virtually non-assessable on that basis since suitable and reliable correlation formulae are hardly known.

Therefore, the fatigue strength has to be determined by fatigue testing; see also Appendix IV. Such testing is normally carried out as four-point bending, with a working stress ratio of $R = -1$. From these results, the bending fatigue strength – surface- or subsurface-initiated depending on the manner of failure – can be determined and expressed as the representative fatigue strength for applied bending in the fillet.

In comparison to bending, the torsion fatigue strength in the fillet may differ considerably from the ratio $\sqrt{3}$ (utilized by the von Mises criterion). The forming-affected depth that is sufficient to prevent subsurface fatigue in bending, may still allow subsurface fatigue in torsion. Another possible reason for the difference in bending and torsion could be the extension of the highly stressed area.

The results obtained in a full-size crank test can be applied for another crank size provided that the base material (alloyed Q+T) is of the similar type and that the forming is done so as to obtain the similar level of compressive residual stresses at the surface as well as through the depth. This means that both the extension and the depth of the cold forming must be proportional to the fillet radius.

6.1 Stroke Peening by Means of a Ball

The fatigue strength obtained can be documented by means of full size crank tests or by empirical methods if applied on the safe side. If both bending and torsion fatigue strengths have been investigated and differ from the ratio $\sqrt{3}$, the von Mises criterion should be excluded.

If only bending fatigue strength has been investigated, the torsional fatigue strength should be assessed conservatively. If the bending fatigue strength is concluded to be $x\%$ above the fatigue strength of the non-peened material, the torsional fatigue strength should not be assumed to be more than $2/3$ of $x\%$ above that of the non-peened material.

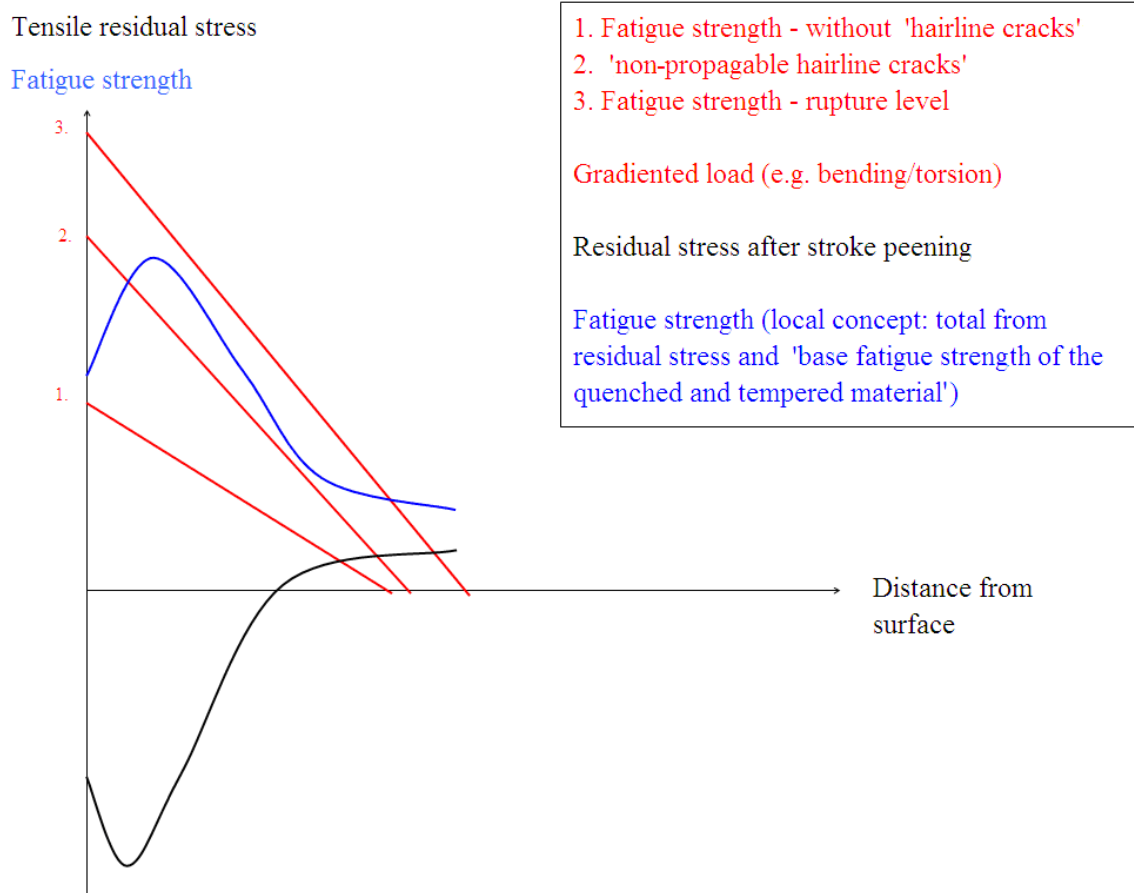

Figure 6.1.
Working and residual stresses below the stroke-peened surface.
Straight lines 1...3 represent different possible load stress gradients.

As a result of the stroke peening process the maximum of the compressive residual stress is found in the subsurface area. Therefore, depending on the fatigue testing load and the stress gradient, it is possible to have higher working stresses at the surface in comparison to the local fatigue strength of the surface. Because of this phenomenon small cracks may appear during the fatigue testing, which will not be able to propagate in further load cycles and/or with further slight increases of the testing load because of the profile of the compressive residual stress. Put simply, the high compressive residual stresses below the surface 'arrest' small surface cracks. This is illustrated in Figure 6.1 as gradient load 2.

In fatigue testing with full-size crankshafts these small "hairline cracks" should not be considered to be the failure crack. The crack that is technically the fatigue crack leading to failure, and that therefore shuts off the test-bench, should be considered for determination of the failure load level. This also applies if induction-hardened fillets are stroke-peened.

In order to improve the fatigue strength of induction-hardened fillets it is possible to apply the stroke peening process in the crankshafts' fillets after they have been induction-hardened and tempered to the required surface hardness. If this is done, it might be necessary to adapt the stroke peening force to the hardness of the surface layer and not to the tensile strength of the base material. The effect on the fatigue strength of induction hardening and stroke peening the fillets shall be determined by a full-size crankshaft test.

6.1.1 Use of Existing Results for Similar Crankshafts

The increase in fatigue strength, which is achieved by applying stroke peening, may be utilized in another similar crankshaft if all of the following criteria are fulfilled:

- ball size relative to fillet radius within $\pm 10\%$ in comparison to the tested crankshaft;
- at least the same circumferential extension of the stroke peening;
- angular extension of the fillet contour relative to fillet radius within $\pm 15\%$ in comparison to the tested crankshaft and located to cover the stress concentration during engine operation;
- similar base material, e.g. alloyed quenched and tempered – Q+T;
- forward feed of ball of the same proportion of the radius;
- force applied to ball proportional to base material hardness (if different);
- force applied to ball proportional to square of ball radius.

6.2 Cold Rolling

The fatigue strength can be obtained by means of full size crank tests or by empirical methods, if these are applied so as to be on the safe side. If both, bending and torsion fatigue strengths have been investigated, and differ from the ratio $\sqrt{3}$, the von Mises criterion should be excluded.

If only bending fatigue strength has been investigated, the torsional fatigue strength should be assessed conservatively. If the bending fatigue strength is concluded to be $x\%$ above the fatigue strength of the non-rolled material, the torsional fatigue strength should not be assumed to be more than $2/3$ of $x\%$ above that of the non-rolled material.

6.2.1 Use of Existing Results for Similar Crankshafts

The increase in fatigue strength, which is achieved applying cold rolling, may be utilized in another similar crankshaft if all of the following criteria are fulfilled:

- at least the same circumferential extension of cold rolling;
- angular extension of the fillet contour relative to fillet radius within $\pm 15\%$ in comparison to the tested crankshaft and located to cover the stress concentration during engine operation;
- similar base material, e.g. alloyed quenched and tempered;
- roller force to be calculated so as to achieve at least the same relative (to fillet radius) depth of treatment.

APPENDIX VI

Guidance for Calculation of Stress Concentration Factors in the Oil Bore Outlets of Crankshafts through Utilisation of the Finite Element Method

Contents

1 General	50
2 Model Requirements	50
2.1 Element Mesh Recommendations	50
2.2 Material	51
2.3 Element Mesh Quality Criteria	51
2.3.1 Principal Stresses Criterion	51
2.3.2 Averaged/Unaveraged Stresses Criterion	51
3 Load Cases and Assessment of Stress	51
3.1 Torsion	51
3.2 Bending	52

1 General

The objective of the analysis described in this document is to substitute the analytical calculation of the stress concentration factor (SCF) at the oil bore outlet with suitable finite element method (FEM) calculated figures. The former method is based on empirical formulae developed from strain gauge readings or photo-elasticity measurements of various round bars. Because use of these formulae beyond any of the validity ranges can lead to erroneous results in either direction, the FEM-based method is highly recommended.

The SCF calculated according to the rules set forth in this document is defined as the ratio of FEM-calculated stresses to nominal stresses calculated analytically. In use in connection with the present method in IACS UR M53, principal stresses shall be calculated.

The analysis is to be conducted as linear elastic FE analysis, and unit loads of appropriate magnitude are to be applied for all load cases.

It is advisable to check the element accuracy of the FE solver in use, e.g. by modelling a simple geometry and comparing the FEM-obtained stresses with the analytical solution.

A boundary element method (BEM) approach may be used instead of FEM.

2 Model Requirements

The basic recommendations and assumptions for building of the FE-model are presented in Subsection 2.1. The final FE-model must meet one of the criteria in Subsection 2.3.

2.1 Element Mesh Recommendations

For the mesh quality criteria to be met, construction of the FE model for the evaluation of stress concentration factors according to the following recommendations is advised:

- The model consists of one complete crank, from the main bearing centre line to the opposite side's main bearing centre line.
- The following element types are used in the vicinity of the outlets:
 - 10-node tetrahedral elements,

- 8-node hexahedral elements,
- 20-node hexahedral elements.
- The following mesh properties for the oil bore outlet are used:
 - maximum element size $a = r / 4$ through the entire outlet fillet as well as in the bore direction (if 8-node hexahedral elements are used, even smaller elements are required for meeting of the quality criterion).
- Recommended manner for element size in the fillet depth direction:
 - first layer thickness equal to element size of a ,
 - second layer thickness equal to element size of $2a$,
 - third layer thickness equal to element size of $3a$.
- In general, the rest of the crank should be suitable for numeric stability of the solver
- Drillings and holes for weight reduction have to be modelled

Submodeling may be used as long as the software requirements are fulfilled.

2.2 Material

UR M53 does not consider material properties such as Young's modulus (E) and Poisson's ratio (ν). In the FE analysis, these material parameters are required, as primarily strain is calculated and stress is derived from strain through the use of Young's modulus and Poisson's ratio. Reliable values for material parameters have to be used, either as quoted in the literature or measured from representative material samples.

For steel the following is advised: $E = 2.05 \cdot 10^5$ MPa and $\nu = 0.3$.

2.3 Element Mesh Quality Criteria

If the actual element mesh does not fulfil any of the following criteria in the area examined for SCF evaluation, a second calculation, with a finer mesh is to be performed.

2.3.1 Principal Stresses Criterion

The quality of the mesh should be assured through checking of the stress component normal to the surface of the oil bore outlet radius. With principal stresses σ_1 , σ_2 and σ_3 the following criterion must be met:

$$\min(|\sigma_1|, |\sigma_2|, |\sigma_3|) < 0.03 \cdot \max(|\sigma_1|, |\sigma_2|, |\sigma_3|)$$

2.3.2 Averaged/Unaveraged – Stresses Criterion

The averaged/unaveraged – stresses criterion is based on observation of the discontinuity of stress results over elements at the fillet for the calculation of the SCF.

Unaveraged nodal stress results calculated from each element connected to a node i should differ less than 5% from the 100% averaged nodal stress results at this node i at the location examined.

3 Load Cases And Assessment Of Stress

For substitution of the analytically determined SCF in UR M53, calculation shall be performed for the following load cases.

3.1 Torsion

The structure is loaded in pure torsion. The surface warp at the end faces of the model is suppressed.

Torque is applied to the central node, on the crankshaft axis. This node acts as the master node with six degrees of freedom and is connected rigidly to all nodes of the end face.

The boundary and load conditions are valid for both in-line- and V-type engines.

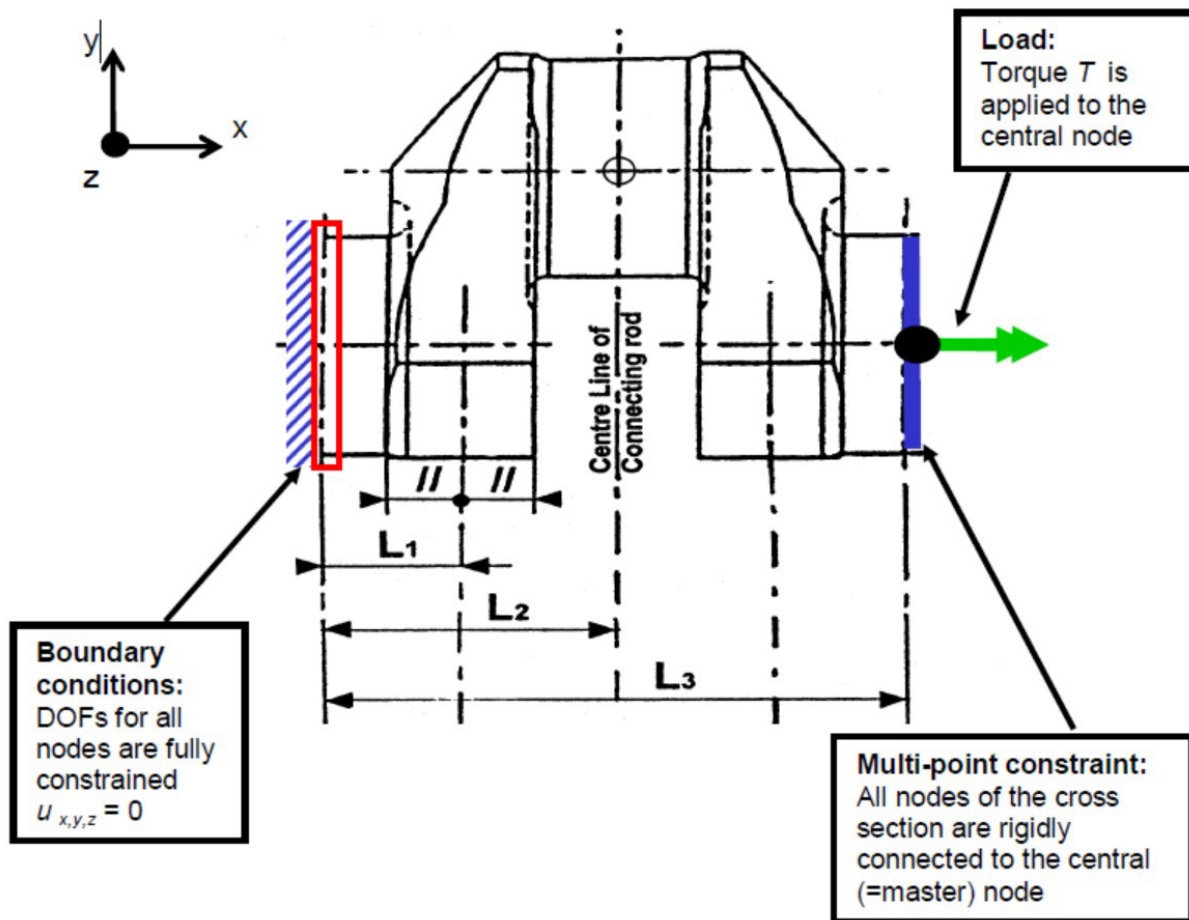

Figure 3.1. Boundary and load conditions for the torsion load case

For all nodes in an oil bore outlet, the principal stresses are obtained and the maximum value is taken for subsequent calculation of the SCF:

$$\gamma_T = \frac{\max(|\sigma_1|, |\sigma_2|, |\sigma_3|)}{\tau_N}$$

where the nominal torsion stress τ_N referred to the crankpin is evaluated per M53.2.2.2 with torque T :

$$\tau_N = \frac{T}{W_p}$$

3.2 Bending

The structure is loaded in pure bending. The surface warp at the end faces of the model is suppressed.

The bending moment is applied to the central node on the crankshaft axis. This node acts as the master node, with six degrees of freedom, and is connected rigidly to all nodes of the end face.

The boundary and load conditions are valid for both in-line- and V-type engines.

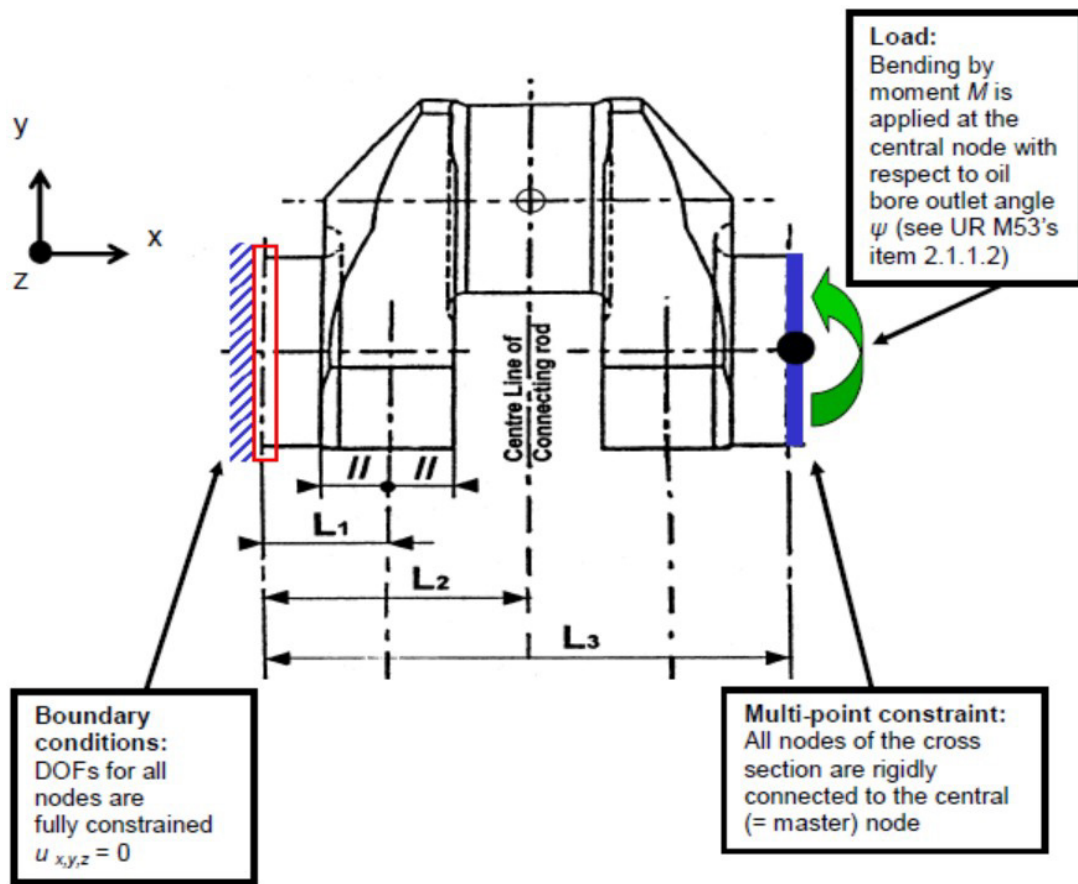

Figure 3.2. Boundary and load conditions for the pure bending load case

For all nodes in the oil bore outlet, principal stresses are obtained and the maximum value is taken for subsequent calculation of the SCF:

$$\gamma_B = \frac{\max(|\sigma_1|, |\sigma_2|, |\sigma_3|)}{\sigma_N}$$

where the nominal bending stress σ_N referred to the crankpin is calculated per M53.2.1.2.2 with bending moment M :

$$\sigma_N = \frac{M}{W_e}$$

List of amendments effective as of 1 July 2024

Item	Title/Subject	Source
Appendix IV p. 4.3	Correcion resulting from UR amendment	UR M53 (Rev.5 May 2013)