



RULES
PUBLICATION 39/P

HULL SURVEYS OF BULK CARRIERS

July
2024

Publications P (Additional Rule Requirements) issued by Polski Rejestr Statków
complete or extend the Rules and are mandatory where applicable.

GDAŃSK

Publication 39/P – Hull Surveys of Bulk Carriers – July 2024, based on the IACS Unified Requirements (UR) Z10.2, Rev.34 and 35 is an extension of the requirements contained in *Part I – Classification Regulations of the Rules for the Classification and Construction of Sea-going Ships*.

This Publication was approved by the PRS Board on 20 June 2024 and enters into force on 1 July 2024.

This Publication replaces the *Publication No. 39/P – Hull Survey of Bulk Carriers – July 2020*.

© Copyright by Polski Rejestr Statków S.A., 2022

PRS/RP.06/2024

CONTENTS

	Page
1 General	5
1.1 Application	5
1.2 Definitions	5
1.3 Repairs	8
1.4 Thickness Measurements and Close-up Surveys	9
2 Annual Survey	9
2.1 Schedule.....	9
2.2 Scope	9
2.3 Additional Annual Survey Requirements for the Foremost Cargo Hold of Ships Subject to SOLAS XII/9.1	12
2.4 Additional Annual Survey Requirements after Determining Compliance with SOLAS XII/12 and XII/13	12
3 Intermediate Survey	12
3.1 Schedule.....	12
3.2 Scope	12
4 Class Renewal Survey	14
4.1 Schedule.....	14
4.2 Scope	15
4.3 Extent of Overall and Close-up Survey.....	16
4.4 Extent of Thickness Measurement.....	17
4.5 Extent of Tank Testing	18
4.6 Additional Class Renewal Survey Requirements after Determining Compliance with SOLAS XII/12 and XII/13	18
5 Preparation for Survey	18
5.1 Survey Programme.....	18
5.2 Conditions for Survey	19
5.3 Access to Structures	20
5.4 Equipment for Survey	21
5.5 Rescue and Emergency Response Equipment.....	21
5.6 Survey at Sea or at Anchorage	21
5.7 Survey Planning Meeting	23
6 Documentation on Board	23
6.1 General.....	23
6.2 Survey Report File.....	23
6.3 Supporting Documents	24
6.4 Review of Documentation on Board	24
7 Procedures for thickness Measurements	25
7.1 General.....	25
7.2 Certification of Thickness Measurement Firm	25
7.3 Number and Locations of Measurements.....	25
7.4 Reporting	31
8 Acceptance Criteria	31
8.1 General.....	31
8.2 Acceptance Criteria for Pitting Corrosion of CSR ships.....	32
8.3 Acceptance Criteria for Edge Corrosion of CSR ships	32
8.4 Acceptance Criteria for Grooving Corrosion of CSR ships.....	33

9 Reporting and Evaluation of Survey	33
9.1 Evaluation of Survey Report.....	33
9.2 Reporting	33

ENCLOSURES

Table I	Minimum Requirements for Close-up Surveys at Class Renewal Surveys of Bulk Carriers	34
Table II	Minimum Requirements for the Thickness Measurements at Class Renewal Surveys of Bulk Carriers	35
Table III	Owner's Inspection Report	36
Table IV	(Superseded by Annex I).....	36
Table V	Procedures for Certification of Firms Engaged in Thickness Measurements of Hull Structures	37
Table VI	Reporting Principles	38
Table VII	Executive Hull Summary	40
Table VIII	Requirements for Extent of Thickness Measurement at those Areas of Substantial Corrosion	40
Annex I	Guidelines for Technical Assessment in Conjunction with Planning for Enhanced Surveys of Bulk Carriers	42
Annex II	Recommended Procedures for Thickness Measurements of Bulk Carriers	49
	Recommended Procedures for Thickness Measurements of Bulk Carriers Under CSR	72
Annex III	Guidelines for the Gauging of the Vertically Corrugated Transverse Watertight Bulkhead Between Holds Nos. 1 and 2	93
Annex IV	Additional Annual Survey Requirements for the Foremost Cargo Hold of Ships subject to SOLAS XII/9.1	95
Annex V	Guidelines for the Gauging of Side Shell Frames and Brackets in Single Skin Bulk Carriers required to comply with the requirements of <i>Publication 63/P – Renewal Criteria for Side Shell Frames and Brackets in Single Side Skin Bulk Carriers and Oil-Bulk-Ore Carriers</i>	96
Annex VIA	Hull Survey Programme	99
Annex VIB	Survey Planning Questionnaire	99

1 GENERAL

1.1 Application

1.1.1 The requirements of this *Publication* apply to all self-propelled bulk carriers other than double skin bulk carriers.

1.1.2 The requirements apply to surveys of hull structure and piping systems in way of the cargo holds, cofferdams, pipe tunnels, void spaces, fuel oil tanks within the cargo length area and all ballast tanks. The requirements are additional to the classification requirements applicable to the remainder of the ship.

1.1.3 The requirements contain the minimum extent of examination, thickness measurement and tank testing. The survey shall be extended when substantial corrosion and/or structural defects are found and shall include additional Close-up Survey when necessary.

1.1.4 Existing ships of 150 m in length and above, intending to carry solid bulk cargoes having a density of 1.78 t/m³, or above, with single deck, topside tanks and hopper tanks, fitted with vertically corrugated transverse watertight bulkheads between cargo holds No. 1 and 2 shall fulfil requirements specified in the *Part II – Hull of the Rules for the Classification and Construction of Sea-going Ships*, and are subject to the additional thickness measurement guidance contained in Annex III not later than at third Class Renewal Surveys.

1.1.5 Ships which are required to comply with *Publication 63/P – Renewal Criteria for Side Shell Frames and Brackets in Single Side Skin Bulk Carriers and Oil-Bulk-Ore Carriers* are subject to the additional thickness measurement guidance contained in Annex V, with respect to the side shell frames and brackets for the purposes of determining compliance with *Publication 63/P* prior to the relevant compliance deadline stipulated in Chapter 1 of *Publication 63/P* and at the subsequent intermediate and Class Renewal Surveys for the purposes of verifying continuing compliance with *Publication 63/P*.

1.1.6 For bulk carriers with hybrid cargo hold arrangements, e.g. with some cargo holds of single side skin and others of double side skin, the requirements of *Publication 64/P – Hull Surveys of Double Skin Bulk Carriers* apply to cargo holds of double side skin and associated wing spaces.

1.2 Definitions

Bulk carrier – a ship which is constructed generally with single deck, double bottom, topside tanks and hopper side tanks in cargo spaces, and is intended primarily to carry dry cargo in bulk. Combination carriers are included. For single side skin combination carriers, additional requirements are specified in *Publication 36/P – Hull Surveys of Oil Tankers*. Ore and combination carriers are not covered by CSR.

CSR – IACS Common Structural Rules; *PRS Publication 84/P – Requirements concerning the construction and strength of the hull and hull equipment of sea-going bulk carriers of 90 m in length and above*.

Ballast tank – a tank which is used **primarily** for salt water ballast or, where applicable, a space which is used for both cargo and salt water ballast (it will be treated as a ballast tank when substantial corrosion has been found in that space).

Overall survey – a survey intended to report on the overall condition of the hull structure and to determine the extent of additional close-up surveys.

Close-up survey – a survey where the details of structural components are within the close visual inspection range of the surveyor, i.e. normally within the reach of hand.

Transverse section – includes all longitudinal members such as plating, longitudinals and girders at the deck, side, bottom, inner bottom, hopper sides, longitudinal bulkheads and bottom in top wing tanks. For transversely framed ships, a transverse section includes adjacent frames and their end connections in way of transverse sections.

Critical structural area – locations which have been identified from calculations to require monitoring or from the service history of the subject ship or from similar or sister ships (if available) to be sensitive to cracking, buckling or corrosion which would impair the structural integrity of the ship.

Renewal thickness (t_{ren}) – the minimum allowable thickness, in mm, below which renewal of structural members shall be performed.

Representative spaces – those spaces which are expected to reflect the condition of other spaces of similar type and service and with similar corrosion prevention systems. When selecting representative spaces account shall be taken of the service and repair history on board and identifiable critical structural areas and/or suspect areas.

Spaces – separate compartments including holds, tanks, cofferdams and void spaces bounding cargo holds, decks and the outer hull

Suspect areas – locations showing substantial corrosion and/or considered by the surveyor to be prone to rapid wastage.

Substantial corrosion – an extent of corrosion such that assessment of corrosion pattern indicates a wastage in excess of 75% of the allowable margins, but within the acceptable limits. For ships built under the CSR, substantial corrosion is an extent of corrosion such that the assessment of the corrosion pattern indicates a measured thickness between $t_{ren} + 0.5$ mm and t_{ren} .

Corrosion prevention system – normally considered a full hard protective coating.

Hard protective coating is usually to be epoxy coating or equivalent. Other coating systems, which are neither soft nor semi-hard coatings, may be considered acceptable as alternatives, provided that they are applied and maintained in compliance with the manufacturer's specification.

Coating condition is defined as follows:

GOOD – condition with only minor spot rusting,

FAIR – condition with local breakdown at edges of stiffeners and weld connections and/or light rusting over 20% or more of areas under consideration, but less than as defined for POOR condition,

POOR – condition with general breakdown of coating over 20% or more of areas or hard scale at 10% or more of areas under consideration.

Cargo length area – that part of the ship which includes all cargo holds and adjacent areas including fuel tanks, cofferdams, ballast tanks and void spaces.

Special consideration or specially considered (in connection with close-up surveys and thickness measurements) – means that sufficient close-up inspection and thickness measurements shall be taken to confirm the actual average condition of the structure under the coating.

Prompt and thorough repair – permanent repair completed at the time of survey to the satisfaction of the Surveyor, therein removing the need for the issuance of any condition of class.

Pitting corrosion – scattered corrosion spots/areas with local material reductions which are greater than the general corrosion in the surrounding area. Pitting intensity is defined in Fig. 1.

Edge corrosion – local corrosion at the free edges of plates, stiffeners, primary support members and around openings. An example of edge corrosion is shown in Fig. 2.

Grooving corrosion – typically local material loss adjacent to weld joints along abutting stiffeners and at stiffener of plate butts or seams. An example of groove corrosion is shown in Fig. 3.

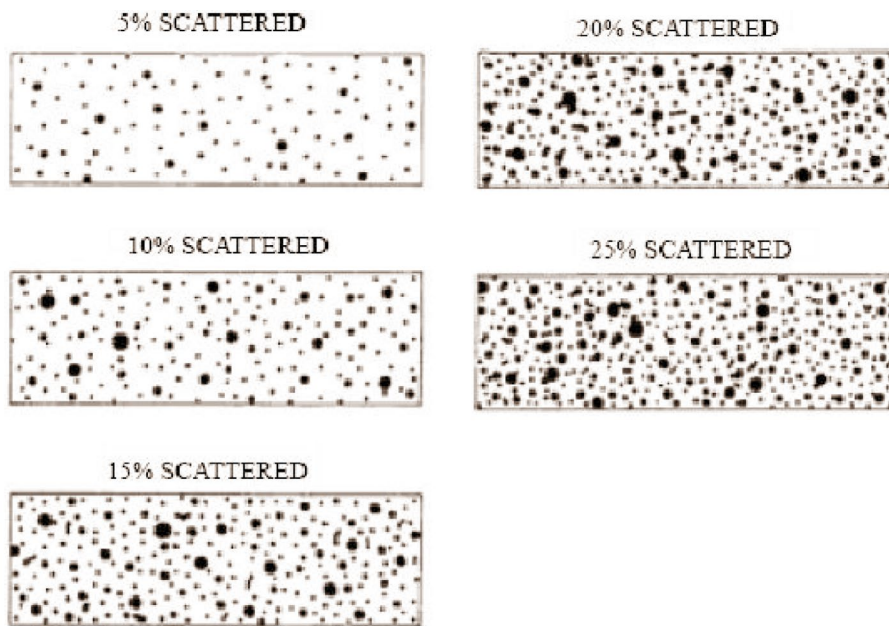

Fig. 1.
Pitting intensity diagrams

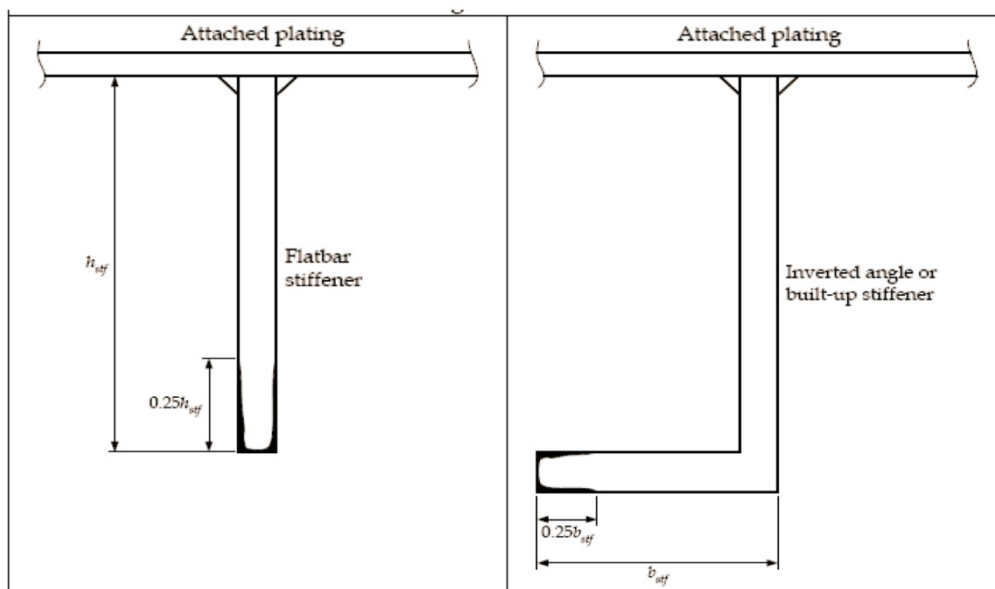

Fig. 2.
Edge corrosion

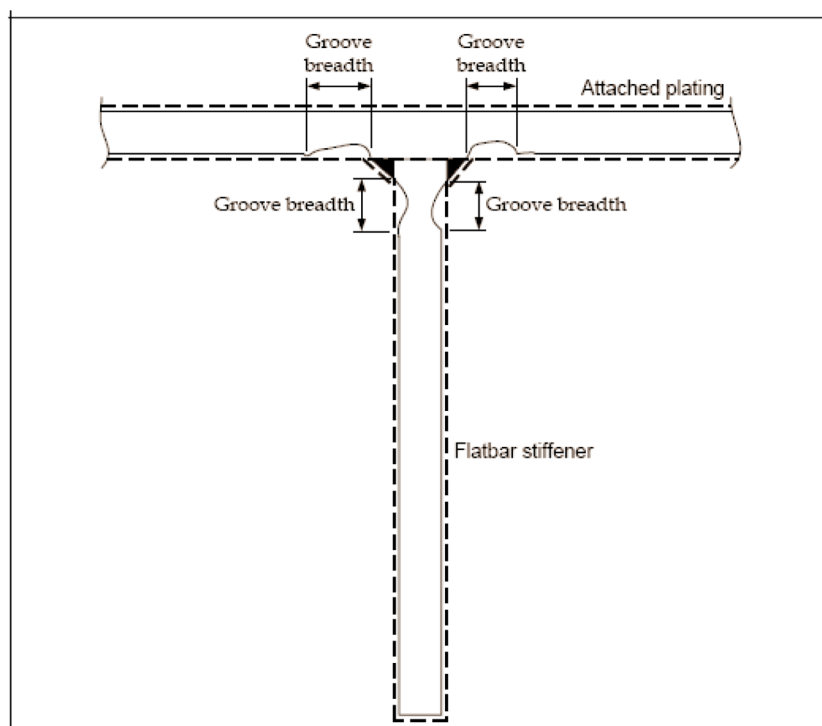

Fig. 3.
Grooving corrosion

1.3 Repairs

1.3.1 Any damage in association with wastage over the allowable limits (including buckling, grooving, detachment or fracture), or extensive areas of wastage over the allowable limits which affects or, in the opinion of the Surveyor, will affect the ship's structural, watertight or weathertight integrity, shall be promptly and thoroughly repaired. Areas to be considered include:

- bottom structure and bottom plating,
- side structure and side plating,
- deck structure and deck plating,
- inner bottom structure and inner bottom plating,
- inner side structure and inner side plating,
- watertight or oiltight bulkheads,
- hatch covers or hatch coamings,
- bunker and vent piping systems, including ventilators.

For locations where adequately repair facilities are not available, consideration may be given to allow the ship to proceed directly to a repair facility. This may require discharging the cargo and/or temporary repairs for the intended voyage.

1.3.2 Additionally, when a survey results in the identification of structural defects or corrosion, either of which, in the opinion of the Surveyor, will impair the vessel's fitness for continued service, remedial measures shall be implemented before the ship continues in service.

1.3.3 Where the damage found on structure mentioned in 1.3.1 is isolated and of a localised nature which does not affect the ship's structural integrity, consideration may be given by the Surveyor to allow an appropriate temporary repair to restore watertight or weathertight integrity and issue a condition of class with a specific time limit.

1.4 Thickness Measurements and Close-up Surveys

In any kind of survey, i.e. class renewal, intermediate, annual or other surveys having the scope of the foregoing ones, thickness measurements when required by Table II, of structures in areas where close-up surveys are required, shall be performed simultaneously with close-up surveys.

2 ANNUAL SURVEY

2.1 Schedule

2.1.1 Annual Surveys shall be held within 3 months before or after anniversary date from the date of the initial classification survey or of the date credited for the last Class Renewal Survey.

2.2 Scope

2.2.1 General

2.2.1.1 The survey shall consist of an examination for the purpose of ensuring, as far as practicable, that the hull, weather decks, hatch covers, coamings and piping are maintained in a satisfactory condition and should take into account the service history, condition and extent of the corrosion prevention system of ballast tanks and areas identified in the survey report file.

2.2.2 Examination of the Hull

2.2.2.1 Examination of the hull plating and its closing appliances as far as can be seen.

2.2.2.2 Examination of watertight penetrations as far as practicable.

2.2.3 Examination of Weather Decks, Hatch Covers and Coamings

2.2.3.1 Confirmation shall be obtained that no unapproved changes have been made to the hatch covers, hatch coamings and their securing and sealing devices since the last survey.

2.2.3.2 A thorough survey of cargo hatch covers and coamings is only possible by examination in the open as well as closed positions and shall include verification of proper opening and closing operation. As a result, the hatch cover sets within the forward 25% of the ship's length and at least one additional set, such that all sets on the ship are assessed at least once in every 5-year period, shall be surveyed open, closed and in operation to the full extent on each direction at each annual survey, including:

- .1** stowage and securing in open condition;
- .2** proper fit and efficiency of sealing in closed condition;
- .3** operational testing of hydraulic and power components, wires, chains, and link drives.

The closing of the covers shall include the fastening of all peripheral, and cross joint cleats or other securing devices. Particular attention shall be paid to the condition of the hatch covers in the forward 25% of the ship's length, where sea loads are normally greatest.

2.2.3.3 If there are indications of difficulty in operating and securing hatch covers, additional sets above those required by 2.2.3.2, at the discretion of the Surveyor, shall be tested in operation.

2.2.3.4 Where the cargo hatch securing system does not function properly, repairs shall be performed under the supervision of PRS. Where hatch covers or coamings undergo substantial repairs, the strength of securing devices should be upgraded to comply with S21.5 of UR S21.

2.2.3.5 For each cargo hatch cover set, at each annual survey, the following items shall be surveyed:



- .1 cover panels, including side plates, and stiffener attachments that may be accessible in the open position by close-up survey (for corrosion, cracks, deformation);
- .2 sealing arrangements of perimeter and cross joints (gaskets for condition and permanent deformation, flexible seals on combination carriers, gasket lips, compression bars, drainage channels and non return valves);
- .3 clamping devices, retaining bars, cleating (for wastage, adjustment, and condition of rubber components);
- .4 closed cover locating devices (for distortion and attachment);
- .5 chain or rope pulleys;
- .6 guides;
- .7 guide rails and track wheels;
- .8 stoppers;
- .9 wires, chains, tensioners, and gypsies;
- .10 hydraulic system, electrical safety devices and interlocks;
- .11 end and interpanel hinges, pins and stools where fitted.

2.2.3.6 At each hatchway, at each annual survey, the coamings, with plating, stiffeners and brackets shall be checked for corrosion, cracks and deformation, especially of the coaming tops, including close-up survey.

2.2.3.7 Where considered necessary, the effectiveness of sealing arrangements may be proved by hose or chalk testing supplemented by dimensional measurements of seal compressing components.

2.2.3.8 Where portable covers, wooden or steel pontoons are fitted, checking the satisfactory condition, where applicable, of:

- wooden covers and portable beams, carriers or sockets for the portable beam, and their securing devices;
- steel pontoons, including close-up survey of hatch cover plating;
- tarpaulins;
- cleats, battens and wedges;
- hatch securing bars and their securing devices;
- loading pads/bars and the side plate edge;
- guide plates and chocks;
- compression bars, drainage channels and drain pipes (if any).

2.2.3.9 Examination of flame screens on vents to all bunker tanks.

2.2.3.10 Examination of bunker and vent piping systems, including ventilators.

2.2.4 Examination of Cargo Holds

2.2.4.1 Bulk carriers 10-15 years of age, the following applies:

- a) Overall survey of all cargo holds.
- b) Close-up survey of sufficient extent, minimum 25% of frames, to establish the condition of the lower region of the shell frames including approx. lower one third length of side frame at side shell and side frame end attachment and the adjacent shell plating in the forward cargo hold. Where this level of survey reveals the need for remedial measures, the survey shall be extended to include a Close-up Survey of all of the shell frames and adjacent shell plating of that cargo hold, as well as a Close-up Survey of sufficient extent of all remaining cargo holds.

- c) When considered necessary by the surveyor, or where extensive corrosion exists, thickness measurement shall be performed. If the results of these thickness measurements indicate that substantial corrosion is found, the extent of thickness measurements shall be increased in accordance with Table VIII.

These thickness measurements shall be performed before the Annual Survey is credited as completed. Suspect areas identified at previous surveys shall be examined. Areas of substantial corrosion identified at previous surveys shall have thickness measurements taken.

For ships built under the CSR, the annual thickness gauging may be omitted where a protective coating has been applied in accordance with the coating manufacturer's requirements and is maintained in good condition.

- d) Where a hard protective coating is fitted in cargo holds and is found in GOOD condition, the extent of close-up surveys and thickness measurements may be specially considered.
e) All piping and penetrations in cargo holds, including overboard piping, shall be examined.

2.2.4.2 Bulk carriers over 15 years of age, the following applies:

- a) Overall survey of all cargo holds.
b) Close-up examination of sufficient extent, minimum 25% of frames, to establish the condition of the lower region of the shell frames including approx. lower one third length of side frame at side shell and side frame end attachment and the adjacent shell plating in the forward cargo hold and one other selected cargo hold. Where this level of survey reveals the need for remedial measures, the survey shall be extended to include a Close-up Survey of all of the shell frames and adjacent shell plating of that cargo hold, as well as a Close-up Survey of sufficient extent of all remaining cargo holds.
c) When considered necessary by the surveyor, or where extensive corrosion exists, thickness measurement shall be performed. If the results of these thickness measurements indicate that substantial corrosion is found, the extent of thickness measurements shall be increased in accordance with Table VIII.

These thickness measurements shall be performed before the Annual Survey is credited as completed. Suspect areas identified at previous surveys shall be examined. Areas of substantial corrosion identified at previous surveys shall have thickness measurements taken.

For ships built under the CSR, the annual thickness gauging may be omitted where a protective coating has been applied in accordance with the coating manufacturer's requirements and is maintained in good condition.

- d) Where a hard protective coating is fitted in cargo holds and is found in GOOD condition, the extent of close-up surveys and thickness measurements may be specially considered.
e) All piping and penetrations in cargo holds, including overboard piping, shall be examined.

2.2.5 Examination of Ballast Tanks

2.2.5.1 Examination of ballast tanks when required as a consequence of the results of the Class Renewal Survey and Intermediate Survey shall be performed.

When considered necessary by the surveyor, or where extensive corrosion exists, thickness measurements shall be performed. If the results of these thickness measurements indicate that substantial corrosion is found, the extent of thickness measurements shall be increased in accordance with Table VIII. These extended thickness measurements shall be performed before the survey is credited as completed.

Suspect areas identified at previous surveys shall be examined. Areas of substantial corrosion identified at previous surveys shall have thickness measurements taken.

For ships built under the CSR, the annual thickness gauging may be omitted where a protective coating has been applied in accordance with the coating manufacturer's requirements and is maintained in good condition.

2.3 Additional Annual Survey Requirements for the Foremost Cargo Hold of Ships Subject to SOLAS XII/9.1

2.3.1 Ships subject to SOLAS XII/9.1 are those meeting all the following conditions:

- bulk carriers of 150 m in length and upwards of single skin construction,
- carrying solid bulk cargoes having density of 1.780 t/m³ and above,
- contracted for construction before 1 July 1999, and
- constructed with an insufficient number of transverse watertight bulkheads to enable them to withstand flooding of the foremost cargo hold in all loading conditions and remain afloat in a satisfactory condition of equilibrium as specified in SOLAS XII/4.3.

2.3.2 In accordance with SOLAS XII/9.1, for the foremost cargo hold of such ships, the additional survey requirements listed in Annex V shall apply.

2.4 Additional Annual Survey Requirements after Determining Compliance with SOLAS XII/12 and XII/13

2.4.1 For ships complying with the requirements of SOLAS XII/12 for hold, ballast and dry space water level detectors, the Annual Survey shall include an examination and a test, at random, of the water ingress detection systems and of their alarms.

2.4.2 For ships complying with the requirements of SOLAS XII/13 for the availability of pumping systems, the Annual Survey shall include an examination and a test, of the means for draining and pumping ballast tanks forward of the collision bulkhead and bilges of dry spaces any part of which extends forward of the foremost cargo hold, and of their controls.

3 INTERMEDIATE SURVEY

3.1 Schedule

3.1.1 The Intermediate Survey shall be held at or between either the 2nd or 3rd Annual Survey.

3.1.2 Those items which are additional to the requirements of the Annual Survey may be surveyed either at or between the 2nd and 3rd Annual Survey.

3.1.3 Surveys and thickness measurements of spaces, once credited towards Class Renewal Survey can not be credited towards Intermediate Survey.

3.2 Scope

3.2.1 General

3.2.1.1 The survey extent is dependent on the age of the vessel as specified in 3.2.2 to 3.2.4.

3.2.2 Bulk carriers 5-10 years of age, the following applies:

3.2.2.1 Ballast Tanks

- a) For tanks used for water ballast, an overall survey of representative spaces selected by the surveyor shall be performed. The selection shall include fore and aft peak tanks and a number of other tanks, taking into account the total number and type of ballast tanks. If such overall survey reveals no visible structural defects, the examination may be limited to verification that the corrosion preventing system remains efficient.
- b) Where a hard coating is found to be less than GOOD condition, corrosion or other defects are found in salt water ballast spaces or where a protective coating was not applied from the time of construction, the examination shall be extended to other ballast tanks of the same type.
- c) In ballast tanks other than double bottom tanks, where a hard protective coating is found in to be less than GOOD condition and it is not renewed, or where soft or semi-hard coating has been applied, or where a hard protective coating was not applied from the time of construction, the tanks in question shall be examined and thickness measurements performed as considered necessary at annual intervals.

When such breakdown of hard protective coating is found in ballast double bottom tanks, or where a soft or semi-hard coating has been applied, or where a hard protective coating has not been applied, the tanks in question may be examined at annual intervals. When considered necessary by the surveyor, or where extensive corrosion exists, thickness measurements shall be performed.

- d) In addition to the requirements above, suspect areas identified at the previous surveys shall be overall and close-up surveyed.

3.2.2.2 Cargo Holds

- a) An overall survey of all cargo holds, including Close-up Survey of sufficient extent, minimum 25% of frames, shall be performed to establish the condition of:
 - shell frames, including their upper and lower attachments, adjacent shell plating, and transverse bulkheads in the forward cargo hold and one other selected cargo hold,
 - areas found as suspect areas at the previous surveys.
- b) Where considered necessary by the surveyor as a result of the overall and Close-up Surveys as described in 3.2.2.2a, the survey shall be extended to include a Close-up Survey of all of the shell frames and adjacent shell plating of that cargo hold, as well as a Close-up Survey of sufficient extent of all remaining cargo holds.

3.2.2.3 Extent of Thickness Measurements

- a) Thickness measurement shall be performed to an extent sufficient to determine both general and local corrosion levels at areas subject to close-up surveys, as described in 3.2.2.2a. The minimum requirement for thickness measurements at the Intermediate Survey are areas found to be suspect areas at the previous surveys.
- b) The extent of thickness measurements may be specially considered provided the Surveyor is satisfied by the Close-up Survey, that there is no structural diminution and that the hard protective coatings are found to be in a GOOD condition.
- c) Where substantial corrosion is found, the extent of thickness measurements shall be increased in accordance with the requirements of Table VIII. These extended thickness measurements shall be performed before the survey is credited as completed. Suspect areas identified at previous surveys shall be examined. Areas of substantial corrosion identified at previous surveys shall have thickness measurements taken.

For ships built under CSR, the identified substantial corrosion areas may be:

- a) protected by coating applied in accordance with the coating manufacturer's requirements and examined at annual intervals to confirm the coating in way is still in good condition, or alternatively
- b) required to be measured at annual intervals.
- d) Where the hard protective coating in cargo holds is found to be in GOOD condition, the extent of close-up surveys may be specially considered.

Explanatory note:

For existing bulk carriers, where Owners may select to coat or recoat cargo holds as noted above, consideration may be given to the extent of the close-up and thickness measurement surveys. Prior to the coating of cargo holds of existing ships, scantlings shall be ascertained in the presence of PRS Surveyor.

3.2.3 Bulk carriers 10 – 15 years of age, the following applies:

3.2.3.1 The requirements of the Intermediate Survey shall be to the same extent to the previous Special Survey as required in 4 and 5.1. However, internal examination of fuel tanks and pressure testing of all tanks are not required unless deemed necessary by the attending surveyor.

3.2.3.2 In application of 3.2.3.1, the Intermediate Survey may be commenced at the second Annual Survey and be progressed during the succeeding year with a view to completion at the third Annual Survey instead of the application of 4.1.4.

3.2.3.3 In application of 3.2.3.1, an underwater survey may be considered in lieu of the requirements of 4.2.2.

3.2.4 Bulk carriers over 15 years of age, the following applies:

3.2.4.1 The requirements of the Intermediate Survey shall be to the same extent as the previous Class Renewal Survey as required in 4 and 5.1. However, internal examination of fuel tanks and pressure testing of all tanks are not required unless deemed necessary by the attending surveyor.

3.2.4.2 In application of 3.2.4.1, the Intermediate Survey may be commenced at the second Annual Survey and be progressed during the succeeding year with a view to completion at the third Annual Survey in lieu of the application of 4.1.4.

3.2.4.3 In application of 3.2.4.1, a survey in dry dock shall be part of the Intermediate Survey. The overall and close-up surveys and thickness measurements, as applicable, of the lower portions of the cargo holds and water ballast tanks shall be performed in accordance with the applicable requirements for intermediate surveys, if not already performed. Lower portions of the cargo holds and ballast tanks are considered to be the parts below light ballast water line.

4 CLASS RENEWAL SURVEY

4.1 Schedule

4.1.1 Class Renewal Surveys shall be performed at 5 years intervals to renew the Class Certificate.

4.1.2 The first Class Renewal Survey shall be completed within 5 years from the date of the initial classification survey and thereafter 5 years from the credited date of the previous Class Renewal Survey. However, an extension of class of 3 months maximum beyond the 5th year can be granted in exceptional circumstances. In this case, the next period of class will start from the expiry date of the Class Renewal Survey before the extension was granted.

4.1.3 For surveys completed within 3 months before the expiry date of the Class Renewal Survey, the next period of class will start from the expiry date of the Class Renewal Survey. For surveys completed more than 3 months before the expiry date of the Class Renewal Survey, the period of class will start from the survey completion date.

In cases where the ship has been laid up or has been out of service for a considerable period because of a major repair or modification and the Owner elects to only perform the overdue surveys, the next period of class will start class renewal survey. If the Owner elects to perform the next due class renewal survey, the period of class will start from the survey completion date.

4.1.4 The Class Renewal Survey may be commenced at the 4th Annual Survey and be progressed with a view to completion by the 5th anniversary date. When the Class Renewal Survey is commenced prior to the 4th Annual Survey, the entire survey shall be completed within 15 months if such work is to be credited to the Class Renewal Survey. See paragraph 1.1.5 and Annex V, for additional thickness measurement guidelines applicable to the side shell frames and brackets on ships subject to compliance with *Publication 63/P – Renewal Criteria for Side Shell Frames and Brackets in Single Side Skin Bulk Carriers and Oil-Bulk-Ore Carriers*.

4.1.5 Surveys and thickness measurements of spaces, once credited towards Intermediate Survey can not be credited towards Class Renewal Survey.

4.2 Scope

4.2.1 General

4.2.1.1 The Class Renewal Survey shall include, in addition to the requirements of the Annual Survey, examination, tests and checks of sufficient extent to ensure that the hull and related piping as required in 4.2.1.3, are in a satisfactory condition and are fit for their intended purpose for the new period of class of 5 years to be assigned, subject to proper maintenance and operation and to periodical surveys being performed at the due dates.

4.2.1.2 All cargo holds, ballast tanks, including double bottom tanks, pipe tunnels, cofferdams and void spaces bounding cargo holds, decks and outer hull plating shall be examined, and this examination shall be supplemented by thickness measurement and testing as required in 4.4 and 4.5, to ensure that the structural integrity remains effective.

The aim of the examination shall discover substantial corrosion, significant deformation, fractures, damages and other structural deterioration, that may be present.

4.2.1.3 All piping systems within the above spaces shall be examined and operationally tested to working pressure to attending surveyor's satisfaction to ensure that tightness and condition remain satisfactory.

4.2.1.4 The survey extent of ballast tanks converted to void spaces shall be specially considered in relation to the requirements for ballast tanks.

4.2.2 Dry Dock Survey

4.2.2.1 A survey in dry dock shall be a part of the Class Renewal Survey. The overall and Close-up Surveys and thickness measurements, as applicable, of the lower portions of the cargo holds and ballast tanks shall be performed in accordance with the applicable requirements for Class Renewal Surveys, if not already performed. Lower portions of the cargo holds and ballast tanks are considered to be the parts below light ballast water line.

4.2.3 Space Protection

4.2.3.1 Where provided, the condition of the corrosion prevention system of ballast tanks shall be examined. For ballast tanks, excluding double bottom tanks, where a hard protective coating is found **to be in less than GOOD** condition and it is not renewed, **or** where soft or semi-hard coating has been applied, or where a hard protective coating has not been applied from the time of construction, the tanks in question shall be examined at annual intervals. Thickness measurements shall be performed as deemed necessary by the surveyor.

When such breakdown of hard protective coating is found in water ballast double bottom tanks, and they are not renewed, where a soft or semi-hard coating has been applied, or where a hard protective coating has not been applied from the time of construction, the tanks in question may be examined at annual intervals. When considered necessary by the surveyor, or where extensive corrosion exists, thickness measurements shall be performed.

4.2.3.2 Where a hard protective coating is provided in cargo holds and is found in GOOD condition, the extent of close-up surveys and thickness measurements may be specially considered.

4.2.4 Hatch Covers and Coamings

The hatch covers and coamings shall be surveyed as follows:

4.2.4.1 A thorough inspection of the items listed in 2.2.3 shall be performed, in addition to all hatch covers and coamings.

4.2.4.2 Checking of the satisfactory operation of all mechanically operated hatch covers shall be made, including:

- stowage and securing in open condition,
- proper fit and efficiency of sealing in closed condition,
- operational testing of hydraulic and power components, wires, chains and link drives.

4.2.4.3 Checking the effectiveness of sealing arrangements of all hatch covers by hose testing or equivalent.

4.2.4.4 Close-up survey and thickness measurement¹ of the hatch cover and coaming plating and stiffeners shall be performed as given in Table I and Table II.

4.3 Extent of Overall and Close-up Survey

4.3.1 An overall survey of all tanks and spaces, shall be performed at each Class Renewal Survey. Fuel oil tanks in the cargo length area shall be surveyed as follows:

Class Renewal Survey No. 1 Age ≤ 5	Class Renewal Survey No. 2 5 < Age ≤ 10	Class Renewal Survey No. 3 10 < Age ≤ 15	Class Renewal Survey No. 4 and subsequent 15 < Age
None	One	Two	Half, minimum two

Notes:

1. These requirements apply to tanks of integral (structural) type.
2. If a selection of tanks is accepted to be examined, then different tanks shall be examined at each Class Renewal Survey, on a rotation basis.
3. Peak tanks (all uses) are subject to internal examination at each Class Renewal Survey.

¹ Subject to cargo hold hatch covers of approved design which structurally have no access to the internals, close-up survey/thickness measurement shall be performed for accessible parts of such hatch cover structures.

4. At Class Renewal Survey No. 3 and subsequent surveys, one deep tank for fuel oil in cargo area shall be included, if fitted.

4.3.2 The minimum requirements for Close-up Surveys at Class Renewal Survey are given in Table I.

4.3.3 The Surveyor may extend the Close-up Survey as deemed necessary taking into account the maintenance of the spaces under survey, the condition of the corrosion prevention system and where spaces have structural arrangements or details which have suffered defects in similar spaces or on similar ships according to available information.

4.3.4 For areas in spaces where hard protective coatings are found to be in GOOD condition, the extent of Close-up Surveys according to Table I may be specially considered. Refer also to 4.2.3.2.

4.4 Extent of Thickness Measurement

4.4.1 The minimum requirements for thickness measurements at Class Renewal Survey are given in Table II. For additional thickness measurement guidelines applicable to the vertically corrugated transverse watertight bulkheads between cargo holds Nos. 1 and 2 on ships subject to compliance with the requirements contained in Supplement to *Part II – Hull of Rules for the Classification and Construction of Sea-going Ships*, reference shall be made to 1.1.4 and Annex III. For additional thickness measurements guidelines applicable to the side shell frames and brackets on ships subject to compliance with requirements contained in *Publication 63/P – Renewal Criteria for Side Shell Frames and Brackets in Single Side Skin Bulk Carriers and Oil-Bulk-Ore Carriers*, reference shall be made to 1.1.5 and Annex V.

4.4.2 Provisions for extended measurements for areas with substantial corrosion are given in Table VIII and as may be additionally specified in the survey programme as required by 5.1. These extended thickness measurements shall be performed before the survey is credited as completed. Suspect areas identified at previous surveys shall be examined. Areas of substantial corrosion identified at previous surveys shall have thickness measurements taken.

For ships built under CSR, the identified substantial corrosion areas may be:

- a) protected by coating applied in accordance with the coating manufacturer's requirements and examined at annual intervals to confirm the coating in way is still in good condition, or alternatively
- b) required to be measured at annual intervals.

4.4.3 The Surveyor may further extend the thickness measurement as deemed necessary.

4.4.4 For areas in tanks where hard protective coating is found to be in a GOOD condition, the extent of thickness measurements according to Table II may be specially considered. Refer also to 4.2.3.2.

4.4.5 Transverse sections shall be chosen where the largest reductions are suspected to occur or are revealed from deck plating measurements, one of which shall be in the amidships area.

4.4.6 Representative thickness measurement to determine both general and local levels of corrosion in the shell frames and their end attachments in all cargo holds and water ballast tanks shall be performed. Thickness measurements are also to be performed to determine the corrosion levels on the transverse bulkhead plating. The extent of thickness measurements may be specially considered provided the surveyor is satisfied by the Close-up Survey, that there is no structural diminution, and that the hard protective coating where applied remains efficient.

4.5 Extent of Tank Testing

4.5.1 All boundaries of water ballast tanks, deep tanks and cargo holds used for water ballast within the cargo length area shall be pressure tested. For fuel oil tanks, only representative tanks shall be pressure tested.

4.5.2 The Surveyor may extend the tank testing as deemed necessary.

4.5.3 Boundaries of ballast tanks shall be tested with a head of liquid to the top of air pipes.

4.5.4 Boundaries of ballast holds shall be tested with a head of liquid to near to the top of hatches.

4.5.5 Boundaries of fuel oil tanks shall be tested with a head of liquid to the highest point that liquid will rise under service conditions. Tank testing of fuel oil tanks may be specially considered based on a satisfactory external examination of the tank boundaries, and a confirmation from the Master stating that the pressure testing has been performed according to the requirements with satisfactory results.

4.5.6 The testing of double bottom tanks and other spaces not designated for the carriage of liquid may be omitted, provided a satisfactory internal examination together with an examination of the tanktop is performed.

4.6 Additional Class Renewal Survey Requirements after Determining Compliance with SOLAS XII/12 and XII/13

4.6.1 For ships complying with the requirements of SOLAS XII/12 for hold, ballast tank and dry space water level detectors, the Class Renewal Survey shall include an examination and a test of the water ingress detection systems and of their alarms.

4.6.2 For ships complying with the requirements of SOLAS XII/13 for the availability of pumping systems, the Class Renewal Survey shall include an examination and a test, of the means for draining and pumping ballast tanks forward of the collision bulkhead and bilges of dry spaces any part of which extends forward of the foremost cargo hold, and of their controls.

5 PREPARATION FOR SURVEY

5.1 Survey Programme

5.1.1 The Owner, in cooperation with PRS, shall work out a specific *Hull Survey Programme* prior to the commencement of any part of:

- the Class Renewal Survey
- the Intermediate Survey, for bulk carriers over 10 years of age.

The *Hull Survey Programme* shall be in a written format based on the information in Annex VIA.

The survey shall not commence until the *Hull Survey Programme* has been agreed.

Prior to the development of the *Hull Survey Programme*, the *Survey Planning Questionnaire* shall be completed by the Owner based on the information set out in Annex VIB, and forwarded to PRS.

The *Hull Survey Programme* at Intermediate Survey may consist of the *Hull Survey Programme* at the previous Class Renewal Survey supplemented by the *Executive Hull Summary* of that Class Renewal Survey and later relevant survey reports.

The *Survey Programme* shall be worked out taking into account any amendments to the survey requirements after the last Class Renewal Survey performed.

5.1.2 In developing the *Survey Programme*, the following documentation shall be collected and consulted with a view to selecting tanks, holds, areas, and structural elements to be examined:

- survey status and basic ship information,
- documentation on-board, as described in 6.2 and 6.3,
- main structural plans (scantling drawings), including information regarding the use of high tensile steels (HTS),
- relevant previous survey and inspection reports from both PRS and the Owner,
- information regarding the use of the ship's holds and tanks, typical cargoes and other relevant data,
- information regarding corrosion prevention level on the newbuilding,
- information regarding the relevant maintenance level during operation.

5.1.3 The submitted *Survey Programme* shall account for and fulfil, as a minimum, the requirements of Tables I, II and para. 4.5 for Close-up Survey, thickness measurement and tank testing, respectively, and shall include relevant information including at least:

- basic ship information and particulars,
- main structural plans (scantling drawings), including information regarding the use of high tensile steels (HTS),
- plan of holds and tanks,
- list of holds and tanks with information on use, protection and condition of coating,
- conditions for survey (e.g. information regarding hold and tank cleaning, gas freeing, ventilation, lighting, etc.),
- provisions and methods for access to structures,
- equipment for surveys,
- nomination of holds, tanks and areas for Close-up Survey (per 4.3),
- nomination of sections for thickness measurement (per 4.4),
- nomination of tanks for tank testing (per 4.5),
- damage experience related to the ship in question.

5.1.4 PRS will advise the Owner of the maximum acceptable structural corrosion diminution levels applicable to the vessel.

5.1.5 Use may also be made of *Guidelines for Technical Assessment in Conjunction with Planning for Enhanced Surveys of Bulk Carriers Class Renewal Survey – Hull*, contained in Annex I.

These guidelines are a recommended tool which may be invoked at the discretion of PRS, when considered necessary and appropriate, in conjunction with the preparation of the required *Survey Programme*.

5.2 Conditions for Survey

5.2.1 The Owner is obliged to secure necessary means for carrying out survey safely, moreover:

- .1** in order to enable the attending Surveyors to perform the survey, provisions for proper and safe access, shall be agreed between the Owner and PRS and shall be in accordance with PRS Instruction to Surveyors, Part I-1, Para 2.3;
- .2** details of the means of access shall be provided in the *Survey Planning Questionnaire*;
- .3** in cases where the provisions of safety and required access are judged by the attending Surveyor(s) not to be adequate, the survey of the spaces involved shall not proceed.

5.2.2 Cargo holds, tanks and spaces shall be safe for access. Cargo holds, tanks and spaces shall be gas-free and properly ventilated. Prior to entering a tank, void or enclosed space, it shall be verified that the atmosphere in the tank is free from hazardous gas and contains sufficient oxygen. Requirements of *Publication 123/P – Safe entry to confined spaces* must be fulfilled.

5.2.3 In preparation for survey and thickness measurements and to allow for a thorough examination, all spaces shall be cleaned including removal from surfaces of all loose accumulated corrosion scale. Spaces shall be sufficiently clean and free from water, scale, dirt, oil residues etc. to reveal corrosion, deformation, fractures, damages, or other structural deterioration as well as the condition of the coating. However, those areas of structure whose renewal has already been decided by the Owner need only be cleaned and descaled to the extent necessary to determine the limits of the areas to be renewed.

5.2.4 Sufficient illumination shall be provided to reveal corrosion, deformation, fractures, damages or other structural deterioration as well as the condition of the coating.

5.2.5 Where soft or semi-hard coatings have been applied, safe access shall be provided for the surveyor to verify the effectiveness of the coating and to perform an assessment of the conditions of internal structures which may include spot removal of the coating. When safe access cannot be provided, the soft or semi-hard coating shall be removed.

5.3 Access to Structures

5.3.1 For Overall Survey, means shall be provided to enable the surveyor to examine the hull structure in a safe and practical way.

5.3.2 For Close-up Surveys of the hull structure, other than cargo hold shell frames, one or more of the following means for access, acceptable to the Surveyor, shall be provided:

- permanent staging and passages through structures
- temporary staging and passages through structures,
- hydraulic arm vehicles such as conventional cherry pickers, lifts and movable platforms,
- portable ladders,
- boats or rafts,
- other equivalent means.

5.3.3 For Close-up Surveys of the cargo hold shell frames of bulk carriers less than 100,000 dwt one or more of the following means for access, acceptable to the surveyor, shall be provided:

- permanent staging and passages through structures,
- temporary staging and passages through structures,
- portable ladder restricted to not more than 5 m in length may be accepted for surveys of lower section of a shell frame including bracket,
- hydraulic arm vehicles such as conventional cherry pickers, lifts and movable platforms,
- boats or rafts, provided the structural capacity of the hold is sufficient to withstand static loads at all levels of water,
- other equivalent means.

5.3.4 For Close-up Surveys of the cargo hold shell frames of bulk carriers 100,000 dwt and above, the use of portable ladders is not accepted, and one or more of the following means for access, acceptable to the Surveyor, shall be provided:

Annual Surveys, Intermediate Survey under 10 years of age and Class Renewal Survey No. 1

- permanent staging and passages through structures,
- temporary staging and passages through structures,
- hydraulic arm vehicles such as conventional cherry pickers, lifts and movable platforms,
- boats or rafts, provided the structural capacity of the hold is sufficient to withstand static loads at all levels of water,
- other equivalent means.

Subsequent Intermediate Surveys and Class Renewal Surveys

- either permanent or temporary staging and passage through structures for close-up survey of at least the upper part of hold frames,
- hydraulic arm vehicles such as conventional cherry pickers for surveys of lower and middle part of shell frames as alternative to staging,
- lifts and movable platforms,
- boats or rafts, provided the structural capacity of the hold is sufficient to withstand static loads at all levels of water,
- other equivalent means.

Notwithstanding the above requirements:

- a) The use of a portable ladder fitted with a mechanical device to secure the upper end of the ladder is acceptable for the close-up examination of sufficient extent, minimum 25% of frames, to establish the condition of the lower region of the shell frames including approx. lower one third length of side frame at side shell and side frame end attachment and the adjacent shell plating of the forward cargo hold at Annual Survey, required in 2.2.4.1.b, and the one other selected cargo hold required in 2.2.4.2.b.
- b) The use of hydraulic arm vehicles or aerial lifts (“Cherry picker”) may be accepted by the attending surveyor for the close-up survey of the upper part of side shell frames or other structures in all cases where the maximum working height is not more than 17 m.

5.4 Equipment for Survey

5.4.1 Thickness measurement is normally to be performed by means of ultrasonic test equipment. The accuracy of the equipment shall be proven to the surveyor as required.

5.4.2 One or more of the following fracture detection procedures may be required if deemed necessary by PRS Surveyor:

- radiographic equipment,
- ultrasonic equipment,
- magnetic particle equipment,
- dye penetrant.

5.4.3 Explosimeter, oxygen-meter, breathing apparatus, lifelines, riding belts with rope and hook and whistles together with instructions and guidance on their use shall be made available during the survey. A safety check-list shall be provided.

5.4.4 Adequate and safe lighting shall be provided for the safe and efficient conduct of the survey.

5.4.5 Adequate protective clothing shall be made available and used (e.g. safety helmet, gloves, safety shoes, etc.) during the survey.

5.5 Rescue and Emergency Response Equipment

If breathing apparatus and/or other equipment is used as rescue and emergency response equipment then it is recommended that the equipment should be suitable for the configuration of the space being surveyed.

5.6 Survey at Sea or at Anchorage

5.6.1 Surveys at sea or at anchorage may be accepted provided the surveyor is given the necessary assistance from the personnel on board. Necessary precautions and procedures for carrying out the survey shall be in accordance with 5.1, 5.2, 5.3 and 5.4.

5.6.2 A communication system shall be arranged between the survey party in the spaces under examination and the responsible officer on deck. This system shall also include the personnel in charge of ballast pump handling if boats or rafts are used.

5.6.3 Surveys of tanks or applicable holds by means of boats or rafts may only be undertaken in the agreement with the PRS Surveyor, who shall take into account the safety arrangements provided, including weather forecasting and ship response under foreseeable conditions and provided the expected rise of water within the tank does not exceed 0.25 m.

5.6.4 When rafts or boats will be used for close-up survey the following conditions shall be fulfilled:

- .1** only rough duty, inflatable rafts or boats, having satisfactory residual buoyancy and stability even if one chamber is ruptured, shall be used;
- .2** the boat or raft shall be tethered to the access ladder and an additional person shall be stationed down the access ladder with a clear view of the boat or raft;
- .3** appropriate lifejackets shall be available for all participants;
- .4** the surface of water in the tank or hold shall be calm (under all foreseeable conditions the expected rise of water within the tank shall not exceed 0.25 m) and the water level stationary. On no account is the level of the water to be rising while the boat or raft is in use;
- .5** the tank, hold or space must contain clean ballast water only. Even a thin sheen of oil on the water is not acceptable;
- .6** at no time the water level shall be allowed to be within 1 m of the deepest under deck web face flat so that the survey team is not isolated from a direct escape route to the tank hatch. Filling to levels above the deck transverses is only to be contemplated if a deck access manhole is fitted and open in the bay being examined, so that an escape route for the survey party is available at all times. Other effective means of escape to the deck may be considered.

5.6.5 Rafts or boats alone may be allowed for inspection of the under deck areas for tanks or spaces, if the depth of the webs is 1.5 m or less.

5.6.6 If the depth of the webs is more than 1.5 m, rafts or boats alone may be allowed only:

- when the coating of the under deck structure is in GOOD condition and there is no evidence of wastage; or
- if a permanent means of access is provided in each bay to allow safe entry and exit. This means:
 - .1** access direct from the deck via a vertical ladder and a small platform fitted approximately 2 m below the deck in each bay; or
 - .2** access to deck from a longitudinal permanent platform having ladders to deck in each end of the tank. The platform shall, for the full length of the tank, be arranged in level with, or above, the maximum water level needed for rafting of under deck structure. For this purpose, the ullage corresponding to the maximum water level shall be assumed not more than 3 m from the deck plate measured at the midspan of deck transverses and in the middle length of the tank.

If neither of the above conditions are met, then staging or and other equivalent means shall be provided for the survey of the under deck areas.

5.6.7 The use of rafts or boats alone in paragraphs 5.6.5 and 5.6.6 does not preclude the use of boats or rafts to move about within a tank during a survey.

5.7 Survey Planning Meeting

5.7.1 The establishment of proper preparation and the close co-operation between the attending PRS Surveyors and the Owner's representatives onboard prior to and during the survey are an essential part in the safe and efficient conduct of the survey. During the survey on board safety meetings shall be held regularly.

5.7.2 Prior to commencement of any part of the renewal and intermediate survey, a survey planning meeting shall be held between the attending PRS Surveyor(s), the Owner's representative in attendance, the thickness measurement firm representative, where involved, and the master of the ship or an appropriately qualified representative appointed by the master or Company, for the purpose to ascertain that all the arrangements envisaged in the survey programme are in place, so as to ensure the safe and efficient conduct of the survey work to be performed. See also 7.1.2.

5.7.3 The following is an indicative list of items that shall be addressed in the meeting:

- .1 schedule of the vessel (i.e. the voyage, docking and undocking manoeuvres, periods alongside, cargo and ballast operations, etc.)
- .2 provisions and arrangements for thickness measurements (i.e. access, cleaning/de-scaling, illumination, ventilation, personal safety);
- .3 extent of the thickness measurements;
- .4 acceptance criteria (refer to the list of minimum thicknesses);
- .5 extent of close-up survey and thickness measurement considering the coating condition and suspect areas/areas of substantial corrosion;
- .6 execution of thickness measurements;
- .7 taking representative readings in general and where uneven corrosion / pitting is found;
- .8 mapping of areas of substantial corrosion;
- .9 communication between attending Surveyor(s), the thickness measurement firm operator(s) and Owner's representative(s) concerning findings.

6 DOCUMENTATION ON BOARD

6.1 General

6.1.1 The Owner shall obtain, supply and maintain on board documentation as specified in 6.2 and 6.3 which shall be readily available for the PRS Surveyor.

6.1.2 The documentation shall be kept on board for the life time of the ship.

6.1.3 For bulk carriers subject to SOLAS Chapter II-1, Part A-1, Regulation 3-10, the Owner shall arrange the updating of the Ship Construction File (SCF) throughout the ship's life whenever a modification of the documentation included in the SCF took place. Documented procedures for updating the SCF shall be included within the Safety Management System.

6.2 Survey Report File

6.2.1 A Survey Report File shall be a part of the documentation on board consisting of:

- reports of structural surveys,
- *Executive Hull Summary*,
- thickness measurement reports.

6.2.2 The Survey Report File shall be available also in the Owner's and PRS offices.

6.3 Supporting Documents

6.3.1 The following additional documentation shall be available on board:

- *Survey Programme* as required by 5.1 until such time as the Class Renewal Survey or Intermediate Survey, as applicable, has been completed,
- main structural plans of cargo holds and ballast tanks (for CSR ships these plans shall include for each structural element both the as-built and renewal thickness. Any thickness for voluntary addition is also to be clearly indicated on the plans. The midship section plan to be supplied on board the ship shall include the minimum allowable hull girder sectional properties for hold transverse section in all cargo holds),
- previous repair history,
- cargo and ballast history,
- reports on inspections by ship's personnel, according to the guidance for reporting as shown in Table III, with reference to:
 - structural deterioration in general,
 - leakages in bulkheads and piping,
 - condition of corrosion prevention system, if any,
- any other information that will help identify critical structural areas and/or suspect areas requiring inspection.

6.3.2 For bulk carriers subject to *SOLAS* Chapter II-1, Part A-1, Regulation 3-10, the *Ship Construction File* (SCF), limited to the items to be retained onboard, shall be available on board.

6.4 Review of Documentation on Board

6.4.1 Prior to survey, the surveyor shall examine the completeness of the documentation on board and its contents as a basis for the survey.

6.4.2 For bulk carriers subject to *SOLAS* Chapter II-1, Part A-1, Regulation 3-10, on completion of the survey, PRS Surveyor shall verify that the update of the Ship Construction File (SCF) has been done whenever a modification of the documentation included in the SCF has taken place.

6.4.2.1 6.4.2.1 For the SCF stored on board ship, the surveyor is to examine the information on board ship. In cases where any major event, including, but not limited to, substantial repair and conversion, or any modification to the ship structures, the surveyor is to also verify that the updated information is kept on board the ship. If the updating of the SCF onboard is not completed at the time of survey, the Surveyor records it and requires confirmation at the next periodical survey.

6.4.2.2 6.4.2.2 For the SCF stored on shore archive, the surveyor is to examine the list of information included on shore archive. In cases where any major event, including, but not limited to, substantial repair and conversion, or any modification to the ship structures, the surveyor is to also verify that the updated information is stored on shore archive by examining the list of information included on shore archive or kept on board the ship. In addition, the surveyor is to confirm that the service contract with of the Archive Center is valid. If the updating of the SCF Supplement ashore is not completed at the time of survey, the Surveyor records it and requires confirmation at the next periodical survey.

6.4.3 For bulk carriers subject to *SOLAS* Chapter II-1, Part A-1, Regulation 3-10, on completion of the survey, PRS Surveyor shall verify that any addition and/or renewal of materials used for construction of the hull structure are documented within the Ship Construction File inventory list.

7 PROCEDURES FOR THICKNESS MEASUREMENTS

7.1 General

7.1.1 Thickness measurements required, if not performed by PRS itself or by a company subcontracted directly by PRS, shall be witnessed by a surveyor on board to the extent necessary to control the process.

7.1.2 The thickness measurement operator shall be a party to the survey planning meeting to be held prior to commencing the survey.

7.1.3 Thickness measurements of structures in areas where Close-up Surveys are required shall be performed simultaneously with Close-up Surveys.

7.1.4 In all cases the extent of thickness measurements shall be sufficient as to represent the actual average condition.

7.2 Certification of Thickness Measurement Firm

7.2.1 The thickness measurement shall be performed by a qualified firm certified by PRS according to the principles stated in Table V.

7.3 Number and Locations of Measurements

7.3.1 Application

7.3.1.1 Paragraph 7.3 applies only to ships built under the CSR². For ships not built under CSR, the requirements for number and locations of measurements are according to the PRS Rules and/or Publications depending on ship's age and structural elements concerned.

7.3.2 Number of Measurements

7.3.2.1 Considering the extent of thickness measurements according to the different structural elements of the ship and surveys (renewal, intermediate and annual), the locations of the points to be measured are given for the most important items of the structure.

7.3.3 Locations of Measurements

7.3.3.1 Table 1 provides explanations and/or interpretations for the application of those requirements indicated in the Rules, which refer to both systematic thickness measurements related to the calculation of global hull girder strength and specific measurements connected to Close-up Surveys.

Fig. 4 to Fig. 9 are provided to facilitate the explanations and/or interpretations given in Table 1, to show typical arrangements of single side skin bulk carriers.

² CSR mean *IACS Common Structural Rules for Bulk Carriers* (IACS CSR for Bulk Carriers) or *IACS Common Structural Rules for Bulk Carriers and Oil Tankers* (IACS CSR BC&OT).

Table 1
Interpretations of Rule requirements for the locations and number of points to be measured for CSR bulk carriers (single skin)

Item	Interpretation	Figure reference
Selected plates on deck, tank top, bottom, double bottom and wind and water area	"Selected" means at least a single point on one out of three plates, to be chosen on representative areas of average corrosion	
All deck, tank top and bottom plates and wind and water strakes	At least two points on each plate to be taken either at each 1/4 extremity of plate or at representative areas of average corrosion	
Transverse section	A transverse section includes all longitudinal members such as plating, longitudinals and girders at the deck, side, bottom; inner bottom and hopper side plating, longitudinal bulkhead and bottom plating in top wing tanks	Fig. 4
All cargo hold hatch covers and coamings	Including plates and stiffeners	Locations of points are given in Fig. 5
Transverse section of deck plating outside line of cargo hatch openings	Two single points on each deck plate (to be taken either at each 1/4 extremity of plate or at representative areas of average corrosion) between the ship sides and hatch coamings in the transverse section concerned	
All deck plating and under deck structure inside line of hatch openings between cargo hold hatches	"All deck plating" means at least two points on each plate to be taken either at each 1/4 extremity of plate or at representative areas of average corrosion. "Under deck structure": at each short longitudinal girder: three points for web plating (fwd/middle/aft), single point for face plate, one point for web plating and one point for face plating of transverse beam in way. At each ends of transverse beams, one point for web plating and one point for face plating	Extent of areas is shown in Annex II (CSR) Sheet 3 Location of points are given in Fig. 9
Selected side shell frames in cargo holds	Includes side shell frame, upper and lower end attachments and adjacent shell plating. 25% of frames: one out of four frames should preferably be chosen throughout the cargo hold length on each side. 50% of frames: one out of two frames should preferably be chosen throughout the cargo hold length on each side. "Selected frames" means at least 3 frames on each side of cargo holds	Extent of areas is shown in Annex II(CSR) Sheet 3. Locations of points are given in Fig. 6
Transverse bulkheads in cargo holds	Includes bulkhead plating, stiffeners and girders, including internal structure of upper and lower stools, where fitted. Two selected bulkheads: one shall be the bulkhead between the two foremost cargo holds and the second may be chosen in other positions	Areas of measurements are shown in Annex II (CSR) Sheet 3 Locations of points are given in Fig. 7
One transverse bulkhead in each cargo hold	This means that the close-up survey and related thickness measurements shall be performed on one side of the bulkhead; the side shall be chosen based on the outcome of the overall survey of both sides. In the event of doubt, the Surveyor may also require (possibly partial) close-up survey on the other side	Areas of measurements are shown in Annex II(CSR) Sheet 3 Locations of points are given in Fig. 7
Transverse bulkheads in one topside, hopper and double bottom ballast tank	Includes bulkhead and stiffening systems. The ballast tank shall be chosen based on the history of ballasting among those prone to have the most severe conditions	Locations of points are given in Fig. 8
Transverse webs in ballast tanks	Includes web plating, face plates, stiffeners and associated plating and longitudinals. One of the representative tanks of each type (i.e. topside or hopper or side tank) shall be chosen in the forward part	Areas of measurements are shown in Annex II (CSR) Sheet 3. Locations of points are given in Fig. 6

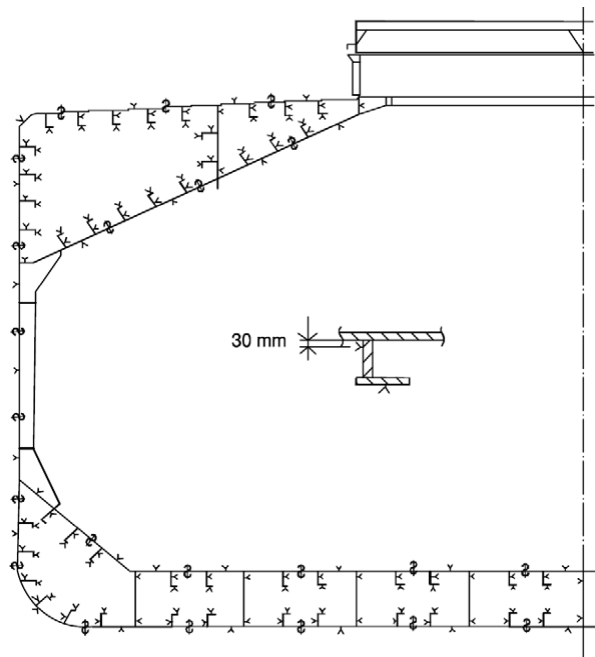

Fig. 4. Transverse section of a single skin bulk carrier

Note: Measurements shall be taken on both port and starboard sides of the selected transverse section.

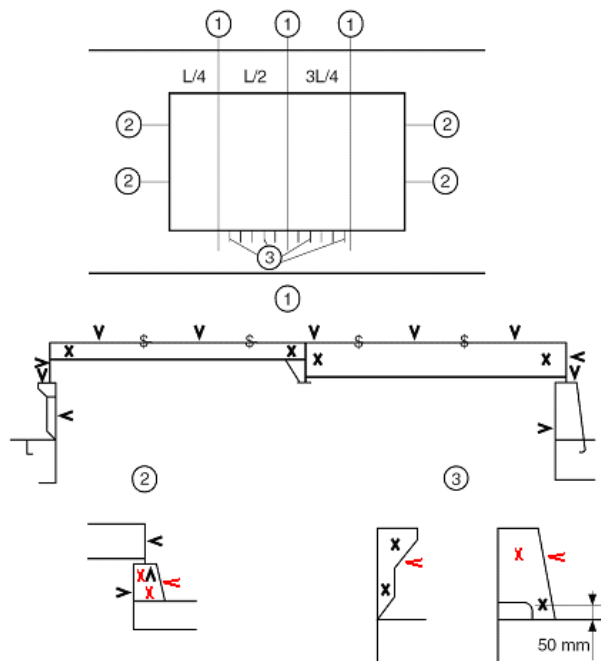

Fig. 5. Locations of measurements on hatch covers and coamings

Notes:

1. Three sections at $L/4$, $L/2$, $3L/4$ of hatch cover length, including:
 - one measurement of each hatch cover plate and skirt plate
 - measurements of adjacent beams and stiffeners
 - one measurement of coaming plates and coaming flange, each side
2. Measurements of both ends of hatch cover skirt plate, coaming plate and coaming flange
3. One measurement (two points for web plate and one point for face plate) of one out of three hatch coaming brackets and bars, on both sides and both ends

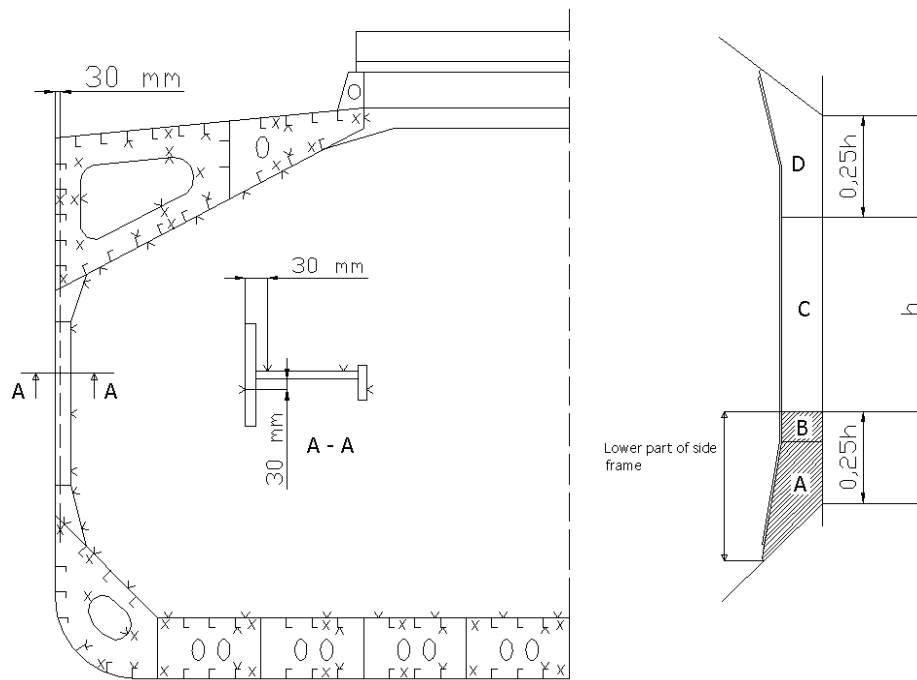

Fig. 6.

Locations of measurements on structural members in cargo holds and ballast tanks of single side skin bulk carriers

Note: The gauging pattern for web plating shall be a three point pattern for zones A, C and D, and a two point pattern for zone B (see figure). The gauging report shall reflect the average reading. The average reading shall be compared with the allowable thickness. If the web plating has general corrosion then this pattern shall be expanded to a five point pattern.

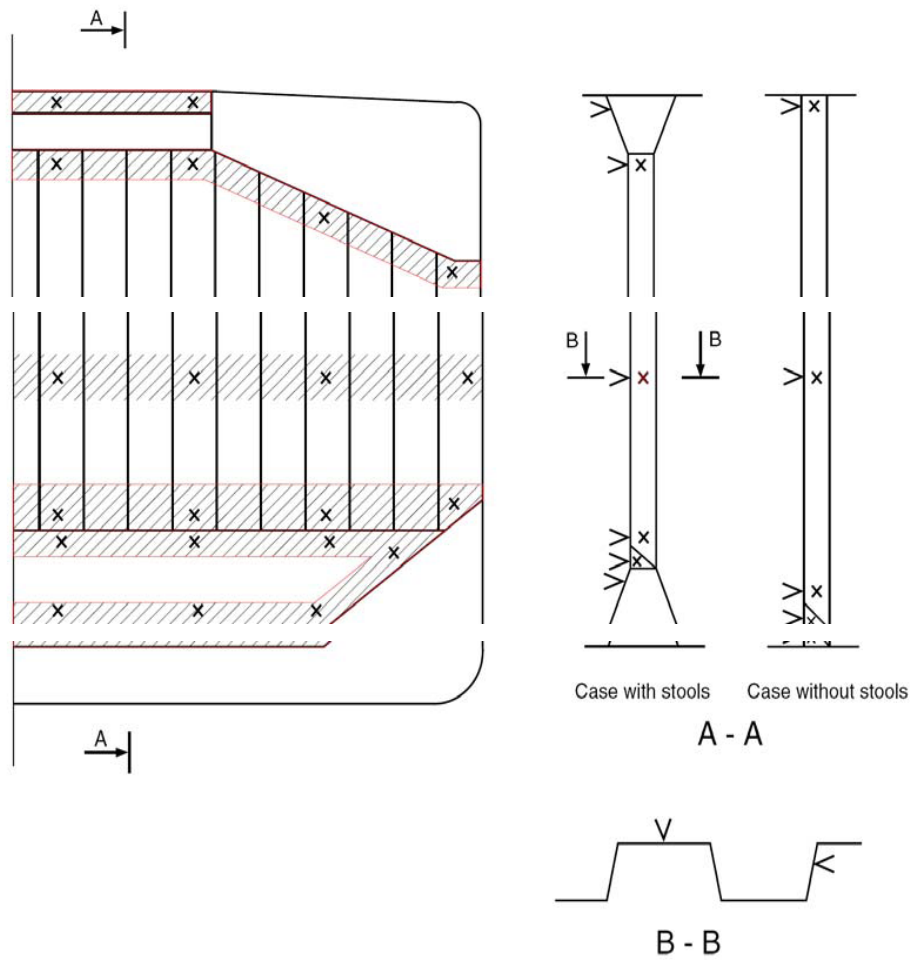

Fig. 7.

Locations of measurements on cargo hold transverse bulkheads (additional measurements to internal structure of upper and lower stools to be added, e. G. Two points in the upper and two points in the lower stools to be indicated in section a - a)

Note: Measurements to be taken in each shaded area as per views A - A and B - B

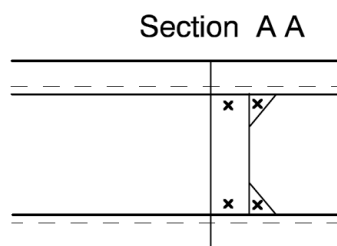
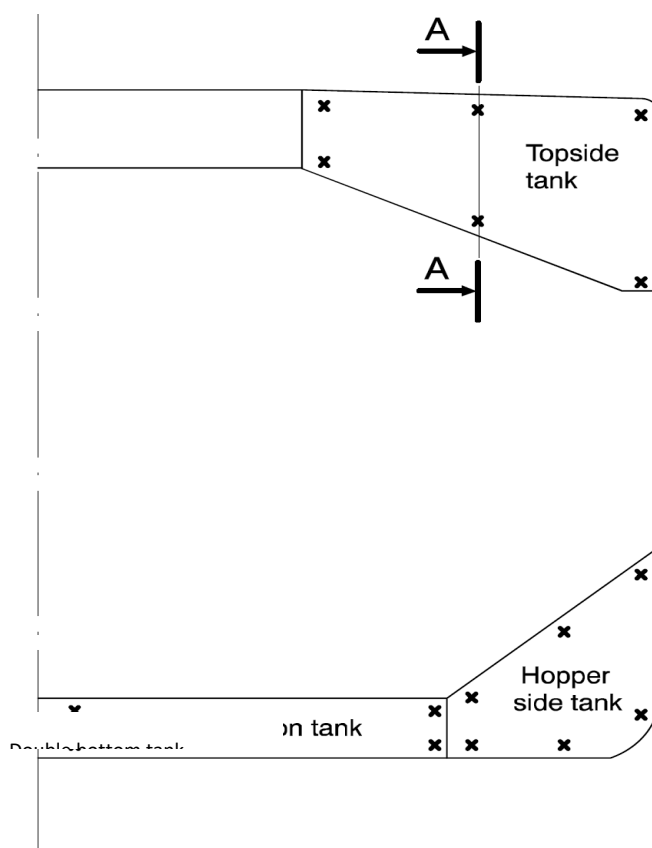

Fig. 8.

Locations of measurements on transverse bulkheads of topside, hopper and double bottom tanks (two additional measurements to internal structure of double bottom tank to be added at midspan)

Note: Measurements to be taken in each vertical section as per view A - A.

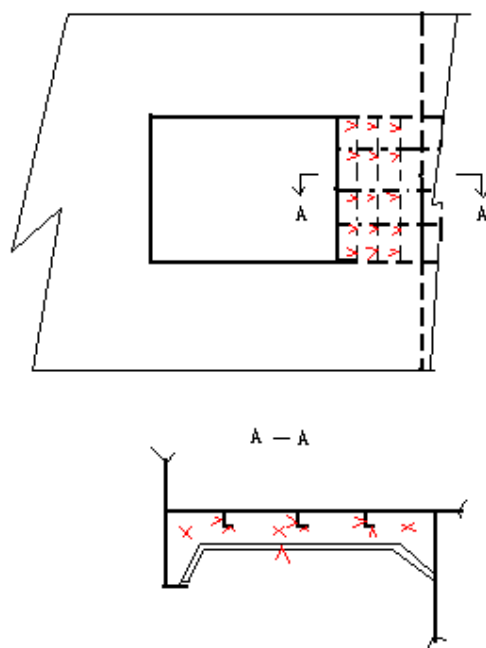

Fig. 9. Locations of measurements on underdeck structure

7.4 Reporting

7.4.1 A thickness measurement report shall be prepared and submitted to PRS. The report shall give the location of measurements, the thickness measured, as well as corresponding original thickness. Furthermore, the report shall give the date when the measurements were performed, type of measuring equipment, names of personnel and their qualifications and has to be signed by the operator.

The thickness measurement report shall follow the principles as specified in the *Recommended Procedures for Thickness Measurements of Bulk Carriers* contained in Annex II.

7.4.2 PRS Surveyor shall review the final thickness measurement report and countersign the cover page.

8 ACCEPTANCE CRITERIA

8.1 General

8.1.1 For ships built under CSR, the Acceptance Criteria is according to IACS CSR³ and as specified in 8.2, 8.3 and 8.4 of present *Publication*.

8.1.2 For ships not built under CSR, the Acceptance Criteria are according to PRS *Rules* and PRS *Publications* depending on ship's age and structural elements concerned, e.g. UR S18 for corrugated transverse watertight bulkheads, UR S19 for the transverse watertight corrugated bulkhead between Cargo Holds Nos. 1 and 2, and URS21 for all cargo hatch covers and hatch forward and side coamings on exposed decks in position 1 (as defined in ILLC), UR S31 for side shell frames, as applicable.

³ Ch.13 of IACS CSR for Bulk Carriers, or Ch. 13, Part 1 of IACS CSR BC&OT.

8.2 Acceptance Criteria for Pitting Corrosion of CSR ships

8.2.1 Side Structures

If pitting intensity in an area where coating is required, according to IACS CSR⁴, is higher than 15% (see Fig. 1), thickness measurements shall be performed to check the extent of pitting corrosion. The 15% is based on pitting or grooving on only one side of a plate.

In cases where pitting is exceeding 15%, as defined above, an area of 300 mm or more, at the most pitted part of the plate, shall be cleaned to bare metal and the thickness shall be measured in way of the five deepest pits within the cleaned area. The least thickness measured in way of any of these pits shall be taken as the thickness to be recorded.

The minimum remaining thickness in pits, grooves or other local areas shall be greater than the following without being greater than the renewal thickness (t_{ren}):

- 75% of the as-built thickness, in the frame and end brackets webs and flanges
- 70% of the as-built thickness, in the side shell, hopper tank and topside tank plating attached to the each side frame, over a width up to 30 mm from each side of it.

8.2.2 Other structures

For plates with pitting intensity less than 20%, see Fig. 1, the measured thickness, t_m of any individual measurement shall meet the lesser of the following criteria:

$$t_m \geq 0.7 (t_{as-built} - t_{vol add}) \text{ mm}$$

$$t_m \geq t_{ren} - 1 \text{ mm}$$

where:

$t_{as-built}$ as-built thickness of the member, in mm;

$t_{vol add}$ voluntary thickness addition; thickness, in mm, voluntarily added as the Owner's extra margin for corrosion wastage in addition to t_c ;

t_{ren} renewal thickness; minimum allowable thickness, in mm, below which renewal of structural members shall be performed;

t_c total corrosion addition, in mm, defined in IACS CSR⁵;

t_m measured thickness, in mm, on one item, i.e. average thickness on one item using the various measurements taken on this same item during periodical ship's in service surveys.

The average thickness across any cross section in the plating shall not be less than the renewal criteria for general corrosion given in IACS CSR⁶.

8.3 Acceptance Criteria for Edge Corrosion of CSR ships

8.3.1 Provided that the overall corroded height of the edge corrosion of the flange, or web in the case of flat bar stiffeners, is less than 25%, see Fig. 2, of the stiffener flange breadth or web height, as applicable, the measured thickness, t_m , shall fulfil the lesser of the following criteria:

$$t_m \geq 0.7 (t_{as-built} - t_{vol add}) \text{ mm}$$

$$t_m \geq t_{ren} - 1 \text{ mm}$$

8.3.2 The average measured thickness across the breadth or height of the stiffener shall not be less than that defined in IACS CSR⁷.

⁴ Sec. 5, Ch. 3 of IACS CSR for Bulk Carriers, or Sec. 4, Ch. 3, Part 1 of IACS CSR BC&OT.

⁵ Sec. 3, Ch. 3 of IACS CSR for Bulk Carriers, or Sec. 3, Ch. 3, Part 1 of IACS CSR BC & OT.

⁶ Ch. 13 of IACS CSR for Bulk Carriers, or Ch. 13, Part 1 of IACS CSR BC & OT.

⁷ Ch. 13 of IACS CSR for Bulk Carriers, or Ch. 13, Part 1 of IACS CSR BC & OT.

8.3.3 Plate edges at openings for manholes, lightening holes etc. may be below the minimum thickness given in IACS CSR⁸ provided that:

- (a) the maximum extent of the reduced plate thickness, below the minimum given in IACS CSR⁹, from the opening edge is not more than 20% of the smallest dimension of the opening and does not exceed 100 mm.
- (b) rough or uneven edges may be cropped-back provided that the maximum dimension of the opening is not increased by more than 10% and the remaining thickness of the new edge is not less than $t_{ren} - 1$ mm.

8.4 Acceptance Criteria for Grooving Corrosion of CSR ships

8.4.1 Where the groove breadth is a maximum of 15% of the web height, but not more than 30 mm, see Fig. 3, the measured thickness, t_m , in the grooved area shall fulfil the lesser of the following criteria:

$$t_m \geq 0.75 (t_{as-built} - t_{vol add}) \text{ mm}$$
$$t_m \geq -0.5 \text{ mm}$$

but shall not be less than $t_m = 6$ mm.

8.4.2 Structural members with areas of grooving greater than those in 8.4.1 above shall be assessed based on the criteria for general corrosion as defined in IACS CSR¹⁰ using the average measured thickness across the plating/stiffener.

9 REPORTING AND EVALUATION OF SURVEY

9.1 Evaluation of Survey Report

9.1.1 The data and information on the structural condition of the vessel, collected during the survey, shall be evaluated for acceptability and continued structural integrity of the vessel.

9.1.1.1 For CSR bulk carriers, the ship's longitudinal strength shall be evaluated by using the thickness of structural members measured, renewed and reinforced, as appropriate, during the class renewal surveys performed after the ship reached 15 years of age (or during the class renewal survey no. 3, if this is performed before the ship reaches 15 years) in accordance with the criteria for longitudinal strength of the ship's hull girder for CSR bulk carriers specified in IACS CSR¹¹.

9.1.1.2 The final result of evaluation of the ship's longitudinal strength required in 9.1.1.1, after renewal or reinforcement work of structural members, if performed as a result of initial evaluation, shall be reported as a part of the *Executive Hull Summary*.

9.2 Reporting

9.2.1 The principles for survey reporting are shown in Table VI.

9.2.2 When a survey is split between different survey stations, a report shall be made for each portion of the survey. A list of items examined and/or tested (pressure testing, thickness measurements etc.) and an indication of whether the item has been credited shall be made available to the next attending surveyor(s) prior to continuing or completing the survey.

⁸ Ch. 13 of IACS CSR for Bulk Carriers, or Ch. 13, Part 1 of IACS CSR BC & OT.

⁹ Ch. 13 of IACS CSR for Bulk Carriers, or Ch. 13, Part 1 of IACS CSR BC & OT.

¹⁰ Ch. 13 of IACS CSR for Bulk Carriers, or Ch. 13, Part 1 of IACS CSR BC & OT.

¹¹ Ch. 13 of IACS CSR for Bulk Carriers, or Ch. 13, Part 1 of IACS CSR BC & OT.

9.2.3 An *Executive Hull Summary* (Form 328HS) of the survey and results shall be issued to the Owner and placed on board the vessel for reference at future surveys. The *Executive Hull Summary* shall be endorsed by the PRS Head Office.

ENCLOSURES

Table I
MINIMUM REQUIREMENTS FOR CLOSE-UP SURVEYS AT CLASS RENEWAL SURVEYS
OF BULK CARRIERS

I class renewal Age ≤ 5 years	II class renewal 5 < Age ≤ 10 years	III class renewal 10 < Age ≤ 15 years	IV and subsequent class renewals Age > 15 years
(A) 25% of shell frames in the forward cargo hold at representative positions.	(A) All shell frames in the forward cargo hold and 25% of shell frames in all cargo holds including upper and lower end attachments and adjacent shell plating. For "100,000 dwt and above" bulk carriers, all shell frames in the forward cargo hold and 50% of shell frames in each remaining cargo hold, including upper and lower end attachments and adjacent shell plating.	(A) All shell frames in the forward and one other selected cargo hold and 50% of frames in each remaining cargo holds, including upper and lower end attachments and adjacent shell plating.	(A) All shell frames in all cargo holds including upper and lower end attachments and adjacent shell plating.
(A) Selected frames in remaining cargo holds.			
(B) One transverse web with associated plating and longitudinals in two representative water ballast tanks of each type (i.e. topside or hopper side tank).	(B) One transverse web with associated plating and longitudinals in each water ballast tank.	(B) All transverse webs with associated plating and longitudinals in each water ballast tank.	Areas (B) – (E) as for Class Renewal Survey No. III.
	(B) Forward and aft transverse bulkhead in one ballast tank, including stiffening system.	(B) All transverse bulkheads in ballast tanks, including stiffening system.	
(I) Two selected cargo hold transverse bulkheads, including internal structure of upper and lower stools, where fitted.	(I) All cargo hold transverse bulkheads, including internal structure of upper and lower stools, where fitted.	(I) (D) and (E) – as for II Class Renewal Survey.	
(D) All cargo hold hatch covers and coamings (plating and stiffeners).	(D) All cargo hold hatch covers and coamings (plating and stiffeners).		
	(E) All deck plating and underdeck structure inside line of hatch openings between cargo hold hatches.		

(A) – Cargo hold transverse frames.

(B) – Transverse web frame or watertight transverse bulkhead in water ballast tanks.

(I) – Cargo hold transverse bulkheads plating, stiffeners and girders.

(D) – Cargo hold hatch covers and coamings. Subject to cargo hold hatch covers of approved design which structurally have no access to the internals, close-up survey/thickness measurement shall be performed for accessible parts of hatch covers structures.

(E) – Deck plating and under deck structure inside line of hatch openings between cargo hold hatches.

See sketches on page 85 for the areas corresponding to (A), (B), (C), (D) and (E). See also sketch in Annex V for zones of side shell frames for ships subject to compliance with *Publication 63/P – Renewal Criteria for Side Shell Frames and Brackets in Single Side Skin Bulk Carrier and Oil-Bulk-Ore Carriers* (p. 111).

Note: Close-up survey of transverse bulkheads to be performed at four levels:

- Level (a) Immediately above the inner bottom and immediately above the line of gussets (if fitted) and shedders for ships without lower stool.
- Level (b) Immediately above and below the lower stool shelf plate (for those ships fitted with lower stools), and immediately above the line of the shedder plates.
- Level I About mid-height of the bulkheads.
- Level (d) Immediately below the upper deck plating and immediately adjacent to the upper wing tank, and immediately below the upper stool shelf plate for those ships fitted with upper stools, or immediately below the topside tanks.

Table II

MINIMUM REQUIREMENTS FOR THE THICKNESS MEASUREMENTS AT CLASS RENEWAL SURVEYS OF BULK CARRIERS

I class renewal Age ≤ 5 years	II class renewal 5 < Age ≤ 10 years	III class renewal 10 < Age ≤ 15 years	IV and subsequent class renewals Age > 15 years
1. Suspect areas	1. Suspect areas	1. Suspect areas	1. Suspect areas
	2. Within the cargo length: a) Two transverse sections of deck plating outside line of cargo hatch openings.	2. Within the cargo length: a) Each deck plate outside line of cargo hatch openings. b) 2 transverse sections, one in the amidships area, outside line of cargo hatch openings. c) all wind and water strakes.	2. Within the cargo length: a) Each deck plate outside line of cargo hatch openings. b) 3 transverse sections, one in the amidships area, outside line of cargo hatch openings. c) Each bottom plate.
	3. Wind and water strakes in way of the 2 transverse sections considered above. Selected wind and water strakes outside the cargo length area.	3. Selected wind and water strakes outside the cargo length area.	3. All wind and water strakes, full length.
	4. Measurements, for general assessment and recording of corrosion pattern, of those structural members subject to close-up survey according to Table I.	4. Measurements, for general assessment and recording of corrosion pattern, of those structural members subject to close-up survey according to Table I.	4. Measurements, for general assessment and recording of corrosion pattern, of those structural members subject to close-up survey according to Table I.
		See 1.1.4 and Annex III for additional thickness measurement guidelines applicable to the vertically corrugated transverse watertight bulkhead between cargo holds Nos. 1 and 2, on ships subject to compliance with requirements contained in <i>Part II – Hull of Rules for the Classification and Construction of Sea-going Ships</i> .	See 1.1.4 and Annex III for additional thickness measurement guidelines applicable to the vertically corrugated transverse watertight bulkhead between cargo holds Nos. 1 and 2, on ships subject to compliance with requirements contained in <i>Part II – Hull of Rules for the Classification and Construction of Sea-going Ships</i> .
	See 1.1.5 and Annex V for additional thickness	See 1.1.5 and Annex V for additional thickness	See 1.1.5 and Annex V for additional thickness

I class renewal Age ≤ 5 years	II class renewal 5 < Age ≤ 10 years	III class renewal 10 < Age ≤ 15 years	IV and subsequent class renewals Age > 15 years
	measurement guidelines applicable to the side shell frames and brackets on ships subject to compliance with requirements contained in <i>Publication 63/P – Renewal Criteria for Side Shell Frames and Brackets in Single Side Skin Bulk Carriers and Oil-Bulk-Ore Carriers.</i>	measurement guidelines applicable to the side shell frames and brackets on ships subject to compliance with requirements contained in <i>Publication 63/P – Renewal Criteria for Side Shell Frames and Brackets in Single Side Skin Bulk Carriers and Oil-Bulk-Ore Carriers.</i>	measurement guidelines applicable to the side shell frames and brackets on ships subject to compliance with requirements contained in <i>Publication 63/P – Renewal Criteria for Side Shell Frames and Brackets in Single Side Skin Bulk Carriers and Oil-Bulk-Ore Carriers.</i>

Table III

Ship's name

**OWNER'S INSPECTION REPORT
Structural condition**

For tank/hold No.

Grade of steel: Deck: Side:
Bottom: Long. Bhd.:

Elements	Cracks	Buckles	Corrosion	Coating condition	Pitting	Modification repairs
Deck						
Bottom						
Sides						
Longitudinal bulkheads						
Transverse bulkheads						
Other						

Repairs performed due to:*)

Thickness measurements performed, dates:

Results in general:

Overdue surveys:

Outstanding conditions of class:

Comments:

*) Repairs shall be surveyed by PRS Surveyor.

Date of inspection:

Inspected by:

Signature:

Table IV

PRINCIPLES FOR PLANNING DOCUMENT

Note: Table IV is superseded by Annex I.



Table V

**PROCEDURES FOR CERTIFICATION OF FIRMS
ENGAGED IN THICKNESS MEASUREMENTS OF HULL STRUCTURES**

1 APPLICATION

This guidance applies to certification of the firms which intend to engage in the thickness measurement of hull structures of the vessels.

2 PROCEDURE FOR CERTIFICATION

2.1 Submission of Documents:

The following documents shall be submitted to PRS HO for approval:

- .1 Outline of firms, e.g. organisation and management structure.
- .2 Experience of the firms on thickness measurement, inter alia of hull structures of the vessels.
- .3 Technicians careers, i.e. experiences of technicians as thickness measurement operators, technical knowledge of hull structure, etc. Operators shall be qualified according to a recognised industrial NDT Standard.
- .4 Equipment used for thickness measurement such as ultrasonic testing machines and its maintenance/ calibration procedures.
- .5 A guide for thickness measurement operators.
- .6 Training programmes of technicians for thickness measurement.
- .7 Measurement record format in accordance with PRS Recommended Procedures for Thickness Measurements of Bulk Carriers contained in Annex II.

2.2 Auditing of the Firms

Upon reviewing the documents submitted with satisfactory results, the firm is audited in order to ascertain that the firm is duly organised and managed in accordance with the documents submitted, and eventually is capable of conducting thickness measurements of the hull construction of the ships.

2.3 Certification is conditional upon an onboard demonstration of thickness measurements, as well as satisfactory reporting.

3 CERTIFICATION

3.1 Upon satisfactory results of both the audit of the firm in 2.2 and the demonstration tests in 2.3 above, PRS will issue a Certificate of Approval, as well as notice to the effect that the thickness measurement operation system of the firm has been certified by PRS.

Note:

Details concerning approval of firms engaged in thickness measurements of hull structures are included in *Publication 51/P – Procedural Requirements for Service Suppliers*.

3.2 Renewal/endorsement of the Certificate shall be made at intervals not exceeding 3 years by verification that original conditions are maintained.

4 INFORMATION OF ANY ALTERATION TO THE CERTIFIED THICKNESS MEASUREMENT OPERATION SYSTEM

In case where any alteration to the certified thickness measurement operation system of the firm is made, such an alteration shall be immediately reported to PRS. Re-audit is made where deemed necessary by PRS.

5 CANCELLATION OF APPROVAL

Approval may be cancelled in the following cases:

- where the measurements were improperly performed or the results were improperly reported;
- where the PRS Surveyor found any deficiencies in the approved thickness measurement operation system of the firm;
- where the firm failed to inform of any alteration in 4 above to PRS.

Table VI

REPORTING PRINCIPLES

As a principle, for bulk carriers subject to ESP, PRS Surveyor shall include the following content in his report for survey of hull structure and piping systems, as relevant for the survey.

1 General

1.1 A survey report shall be generated in the following cases:

- in connection with commencement, continuation and/or completion of periodical hull surveys, i.e. annual, intermediate and special surveys, as relevant;
- when structural damages/defects have been found;
- when repairs, renewals or modifications have been performed;
- when recommendations have been imposed or deleted.

1.2 The purpose of reporting shall provide:

- evidence that prescribed surveys have been performed in accordance with applicable PRS Rules;
- documentation of surveys performed with findings, repairs performed and recommendation imposed or deleted;
- survey records, including actions taken, which shall form an auditable documentary trail. Survey reports shall be kept in the survey report file required to be on board;
- information for planning of future surveys;
- information which may be used as input for maintenance of classification rules and instructions.

1.3 When a survey is split between different survey stations, a report shall be made for each portion of the survey. A list of items surveyed, relevant findings and an indication of whether the item has been credited, shall be made available to the next attending surveyor, prior to continuing or completing the survey. Thickness measurement and tank testing performed is also to be listed for the next Surveyor.

2 Extent of Survey

2.1 Identification of compartments where an overall survey has been performed.

2.2 Identification of locations, in each ballast tank and cargo hold including hatch covers and coamings, where a close-up survey has been performed, together with information of the means of access used.

2.3 Identification of locations, in each ballast tank and cargo hold including hatch covers and coamings, where thickness measurement has been performed.

Note:

As a minimum, the identification of location of Close-up Survey and thickness measurement shall include a confirmation with description of individual structural members corresponding to the extent of requirements stipulated in the present Publication based on type of periodical survey and the ship's age. Where only partial survey is required, i.e. 25% of shell frames, one transverse web, two selected cargo hold transverse bulkheads, the identification shall include location within each ballast tank and cargo hold by reference to frame numbers.

2.4 For areas in ballast tanks and cargo holds where protective coating is found to be in GOOD condition and the extent of Close-up Survey and/or thickness measurement has been specially considered, structures subject to special consideration shall be identified.

2.5 Identification of tanks subject to tank testing.

2.6 Identification of piping systems on deck and within cargo holds, ballast tanks, pipe tunnels, cofferdams and void spaces, where:

- examination including internal examination of piping with valves and fittings and thickness measurement, as relevant, has been performed;
- operational test to working pressure has been performed.

3 Result of the Survey

3.1 Type, extent and condition of protective coating in each tank, as relevant (rated GOOD, FAIR or POOR).

3.2 Structural condition of each compartment with information on the following, as relevant:

- .1** Identification of findings, such as:
 - corrosion with description of location, type and extent;
 - areas with substantial corrosion;
 - cracks / fractures with description of location and extent;
 - buckling with description of location and extent;
 - indents with description of location and extent
- .2** Identification of compartments where no structural damages/defects are found.
The report may be supplemented by sketches/photos.

3.3 Thickness measurement report shall be verified and signed by the Surveyor controlling the measurements on board.

4 Actions Taken with Respect to Findings

4.1 Whenever the attending Surveyor is of the opinion that repairs are required, each item to be repaired shall be identified in the survey report. Whenever repairs are performed, details of the repairs effected shall be reported by making specific reference to relevant items in the survey report.

4.2 Repairs performed shall be reported with identification of:

- compartment;
- structural member;
- repair method (i.e. renewal or modification) including:
 - steel grades and scantlings (if different from the original);
 - sketches/photos, as appropriate;
- repair extent,
- NDT / tests.

4.3 For repairs not completed at the time of survey, recommendation shall be imposed with a specific time limit for the repairs. In order to provide correct and proper information to the Surveyor attending for survey of the repairs, recommendation shall be sufficiently detailed with identification of each item to be repaired.

For identification of extensive repairs, reference may be given to the survey report.

5 Forms

To fulfil the reporting requirements resulting from Hull Survey of Bulk Carrier, the following Forms shall be used:

- 328M – Bulk Carrier Hull Survey Report (renewal),
- 328.1M – Bulk Carrier Hull Survey Report (annual/intermediate),
- 328HS – Executive Hull Summary,
- 328.1HS – Preliminary Executive Hull Summary,
- 328DP – Data on Hull Surveys,
- DSR – Data Sheet for Reporting,

Other related to survey reports (e.g. 305).

Table VII

EXECUTIVE HULL SUMMARY

Form 328.1HS and 328HS shall be used.

Table VIII

REQUIREMENTS FOR EXTENT OF THICKNESS MEASUREMENT AT THOSE AREAS OF SUBSTANTIAL CORROSION

Class Renewal Survey of Bulk Carriers within the Cargo Area

SHELL STRUCTURES

Structural member	Extent of measurement	Pattern of measurement
1. Bottom and side shell plating	a. Suspect plate, plus four adjacent plates b. See other tables for particulars on gauging in way of tanks and cargo holds	a. 5 point pattern for each panel between longitudinals
2. Bottom/side shell longitudinals	Minimum of three longitudinals in way of suspect areas	3 measurements in line across web 3 measurements on flange

TRANSVERSE BULKHEADS IN CARGO HOLDS

Structural member	Extent of measurement	Pattern of measurement
1. Lower stool	a. Transverse band within 25 mm of welded connection to inner bottom b. Transverse band within 25 mm of welded connection to shelf plate	a. 5 point pattern between stiffeners over 1 metre length b. Ditto
2. Transverse bulkhead	a. Transverse band at approximately mid height b. Transverse band at part of bulkhead adjacent to upper deck or below upper stool shelf plate (for those ships fitted with upper stools)	a. 5 point pattern over 1 sq. metre of plating b. 5 point pattern over 1 sq. metre of plating

Table VIII cont'd

**DECK STRUCTURE INCLUDING CROSS STRIPS, MAIN CARGO
HATCHWAYS, HATCH COVERS, COAMINGS AND TOPSIDE TANKS**

Structural member	Extent of measurement	Pattern of measurement
1. Cross deck strip plating	Suspect cross deck strip plating	a. 5 point pattern between underdeck stiffeners over 1 metre length
2. Underdeck stiffeners	a. Transverse members b. Longitudinal member	a. 5 point pattern at each end and mid span b. 5 point pattern on both web and flange
3. Hatch covers	a. Side and end skirts, each 3 locations b. 3 longitudinal bands, outboard strakes (2) and centreline strake (1)	a. 5 point pattern at each location b. 5 point measurement each band
4. Hatch coamings	Each side and end of coaming, one band lower 1/3, one band upper 2/3 of coaming	5 point measurement each band, i.e. end or side coaming
5. Topside water ballast tanks	a. Watertight transverse bulkheads I. lower 1/3 of bulkhead II. upper 2/3 of bulkhead III. stiffeners b. 2 representative swash transverse bulkheads I. lower 1/3 of bulkhead II. upper 2/3 of bulkhead III. stiffeners c. 3 representative bays of slope plating I. lower 1/3 of tank II. upper 2/3 of tank d. Longitudinals, suspect and adjacent	I. 5 point pattern over 1 sq. metre of plating II. 5 point pattern over 1 sq. metre of plating III. 5 point pattern over 1 metre length I. 5 point pattern over 1 sq. metre of plating II. 5 point pattern over 1 sq. metre of plating III. 5 point pattern over 1 metre length I. 5 point pattern over 1 sq. metre of plating II. 5 point pattern over 1 sq. metre of plating d. 5 point pattern both web and flange over 1 metre length
6. Main deck plating	Suspect plates and adjacent (4)	5 point pattern over 1 sq. metre of plating
7. Main deck longitudinals	Minimum of 3 longitudinals where plating measured	5 point pattern on both web and flange over 1 metre length
8. Web frames/transverses	Suspect plates	5 point pattern over 1 sq. metre

DOUBLE BOTTOM AND HOPPER STRUCTURE

Structural member	Extent of measurement	Pattern of measurement
1. Inner/double bottom plating	Suspect plate plus all adjacent plates	5 point pattern for each panel between longitudinals over 1 metre length
2. Inner/double bottom longitudinals	Three longitudinals where plates measured	3 measurements in line across web and 3 measurements on flange
3. Longitudinal girders or transverse floors	Suspect plates	5 point pattern over about 1 square metre
4. Watertight bulkheads (WT floors)	a. lower 1/3 of tank b. upper 2/3 of tank	a. 5 point pattern over 1 sq. metre of plating b. 5 point pattern alternate plates over 1 sq. metre of plating
5. Web frames	Suspect plate	5 point pattern over 1 sq. metre of plating
6. Bottom/side shell longitudinals	Minimum of three longitudinals in way of suspect areas	3 measurements in line across web 3 measurements on flange

CARGO HOLDS

Structural member	Extent of measurement	Pattern of measurement
1. Side shell frames	Suspect frame and each adjacent	a. At each end and mid span: 5 point pattern of both web and flange b. 5 point pattern within 25 mm of welded attachment to both shell and lower slope plate

Annex I**GUIDELINES FOR TECHNICAL ASSESSMENT IN CONJUNCTION WITH PLANNING
FOR ENHANCED SURVEYS OF BULK CARRIERS****CLASS RENEWAL SURVEY – HULL**

Contents	Page
1 INTRODUCTION	43
2 PURPOSE AND PRINCIPLES	43
2.1 Purpose	43
2.2 Minimum Requirements	43
2.3 Timing	43
2.4 Aspects to be Considered	43
3 TECHNICAL ASSESSMENT	44
3.1 General	44
3.2 Methods	44
3.2.1 Design Details	44
3.2.2 Corrosion	45
3.2.3 Locations for Close-up Survey and Thickness Measurements	45

References:

1. *Publication 39/P – Hull Surveys of Bulk Carriers.*
2. TSCF¹⁾, *Guidance Manual for the Inspection and Condition Assessment of Tanker Structures, 1986*²⁾.
3. TSCF¹⁾, *Condition Evaluation and Maintenance of Tanker Structures, 1992*²⁾.
4. IACS, *Bulk Carriers: Guidelines for Surveys, Assessment and Repair of Hull Structure, 1994.*

¹⁾ Tanker Structure Co-operative Forum.

²⁾ For use by PRS Surveyors mainly. Available on request.

1 INTRODUCTION

These guidelines contain information and suggestions concerning technical assessments which may be of use in conjunction with the planning of enhanced Class Renewal Surveys of bulk carriers.

As indicated in 5.1.5 of the present *Publication*, the guidelines are a recommended tool which may be invoked at the discretion of PRS, when considered necessary and appropriate, in conjunction with the preparation of the required *Survey Programme*.

2 PURPOSE AND PRINCIPLES

2.1 Purpose

The purpose of the technical assessment described in these guidelines shall assist in identifying critical structural areas, nominating suspect areas and in focusing attention on structural elements or areas of structural elements which may be particularly susceptible to, or evidence a history of, wastage or damage. This information may be useful in nominating locations, areas, holds and tanks for thickness measurements, Close-up Survey and tank testing.

Critical structural areas are locations which have been identified from calculations to require monitoring or from the service of the subject ship or from similar or sister ships (if available) to be sensitive to cracking, buckling or corrosion which would impair the structural integrity of the ship.

2.2 Minimum Requirements

However, these guidelines may not be used to reduce the requirements pertaining to thickness measurements, close-up survey and tank testing contained in Tables I, II and paragraph 4.5, respectively, of the present *Publication*, which are, in all cases, to be complied with as a minimum.

2.3 Timing

As with other aspects of survey planning, the technical assessment described in these guidelines shall be worked out by the Owner or operator in cooperation with PRS well in advance of the commencement of the Class Renewal Survey, i.e. prior to commencing the survey and normally at least 12 to 15 months before the survey's completion due date.

2.4 Aspects to be Considered

Technical assessment, which may include quantitative or qualitative evaluation of relative risks of possible deterioration of the following aspects of a particular ship may be used as a basis for the nomination of holds, tanks and areas for survey:

- Design features such as stress levels on various structural elements, design details and extent of use of high tensile steel.
- Former history with respect to corrosion, cracking, buckling, indents and repairs for the particular ship, as well as similar vessels, where available.
- Information with respect to types of cargo carried, protection of tanks and condition of coating, if any, of holds and tanks.

Technical assessment of the relative risks of susceptibility to damage or deterioration of various structural elements and areas shall be judged and decided on the basis of recognised principles and practices, such as may be found in the IACS publication “Bulk Carriers: Guidelines for Surveys, Assessment and Repair of Hull Structure” (see References p. 4).

3 TECHNICAL ASSESSMENT

3.1 General

There are three basic types of possible failure which may be the subject of technical assessment in connection with planning of surveys: corrosion, cracks and buckling. Contact damages are not normally covered by the survey plan since indents are usually noted in memoranda and assumed to be dealt with as a normal routine by surveyors.

Technical assessment performed in conjunction with the survey planning process are, in principle, to be as shown schematically in Figure 1. Figure 1 depicts how technical assessment can be performed in conjunction with the survey planning process. The approach is basically an evaluation of the risk in the following aspects based on the knowledge and experience related to design and corrosion.

The design shall be considered with respect to structural details which may be susceptible to buckling or cracking as a result of vibration, high stress levels or fatigue.

Corrosion is related to the ageing process and is closely connected with the quality of corrosion protection at newbuilding, and subsequent maintenance during the service life. Corrosion may also lead to cracking and/or buckling.

3.2 Methods

3.2.1 Design Details

Damage experience related to the ship in question and similar ships, where available, is the main source of information to be used in the process of planning. In addition, a selection of structural details from the design drawings shall be included.

Typical damage experience to be considered will consist of:

- number, extent, location and frequency of cracks,
- location of buckles.

This information may be found in the survey reports and/or the Owner's files, including the results of the Owner's own inspection. The defects shall be analysed, noted and marked on sketches.

In addition, general experience shall be utilised. For example, Figure 2 shows typical locations in bulk carriers which experience has shown may be susceptible to structural damage. Reference shall also be made to IACS' "Bulk Carriers: Guidelines for Surveys, Assessment and Repair of Hull Structure" (see References p. 4), which contains a catalogue of typical damages and proposed repair methods for various bulk carrier structural details.

Such figures shall be used together with a review of the main drawings, in order to compare with the actual structure and search for similar details which may be susceptible to damage. An example is given in Figure 3.

The review of the main structural drawings, in addition to using the above mentioned figures, shall include checking for typical design details where cracking has been experienced. The factors contributing to damage shall be carefully considered.

The use of high tensile steel (HTS) is an important factor. Details showing good service experience where ordinary, mild steel has been used may be more susceptible to damage when HTS, and its higher associated stresses are utilised. There is extensive and, in general, good experience, with the use of HTS for longitudinal material in deck and bottom structures. Experience in other locations, where the dynamic stresses may be higher, is less favourable, e.g. side structures.

In this respect, stress calculations of typical and important components and details, in accordance with the latest Rules or other relevant methods, may prove useful and shall be considered.

The selected areas of the structure identified during this process shall be recorded and marked on the structural drawings to be included in the *Survey Programme*.

3.2.2 Corrosion

In order to evaluate relative corrosion risks, the following information is generally to be considered:

- usage of tanks, holds and spaces,
- condition of coatings,
- cleaning procedures,
- previous corrosion damage,
- ballast use and time for cargo holds,
- risk of corrosion in cargo holds and ballast tanks,
- location of ballast tanks adjacent to heated fuel oil tanks.

“Condition Evaluation and Maintenance of Tanker Structures, 1992”, (Ref. 3) gives definitive examples which can be used for judging and describing coating condition, using typical pictures of conditions.

The evaluation of corrosion risks shall be based on information in Ref. 4, together with relevant information on the anticipated condition of the ship as derived from the information collected in order to prepare the *Survey Programme* and the age of the ship.

The various tanks, holds and spaces shall be listed with the corrosion risks nominated accordingly.

3.2.3 Locations for Close-up Survey and Thickness Measurements

On the basis of the table of corrosion risks and the evaluation of design experience, the locations for initial Close-up Survey and thickness measurement (sections) may be nominated.

The sections subject to thickness measurement shall normally be nominated in tanks, holds and spaces where corrosion risk is judged to be the highest.

The nomination of tanks, holds and spaces for Close-up Survey shall, initially, be based on the highest corrosion risk and shall always include ballast tanks. The principle for the selection shall be that the extent is increased by age or where information is insufficient or unreliable.

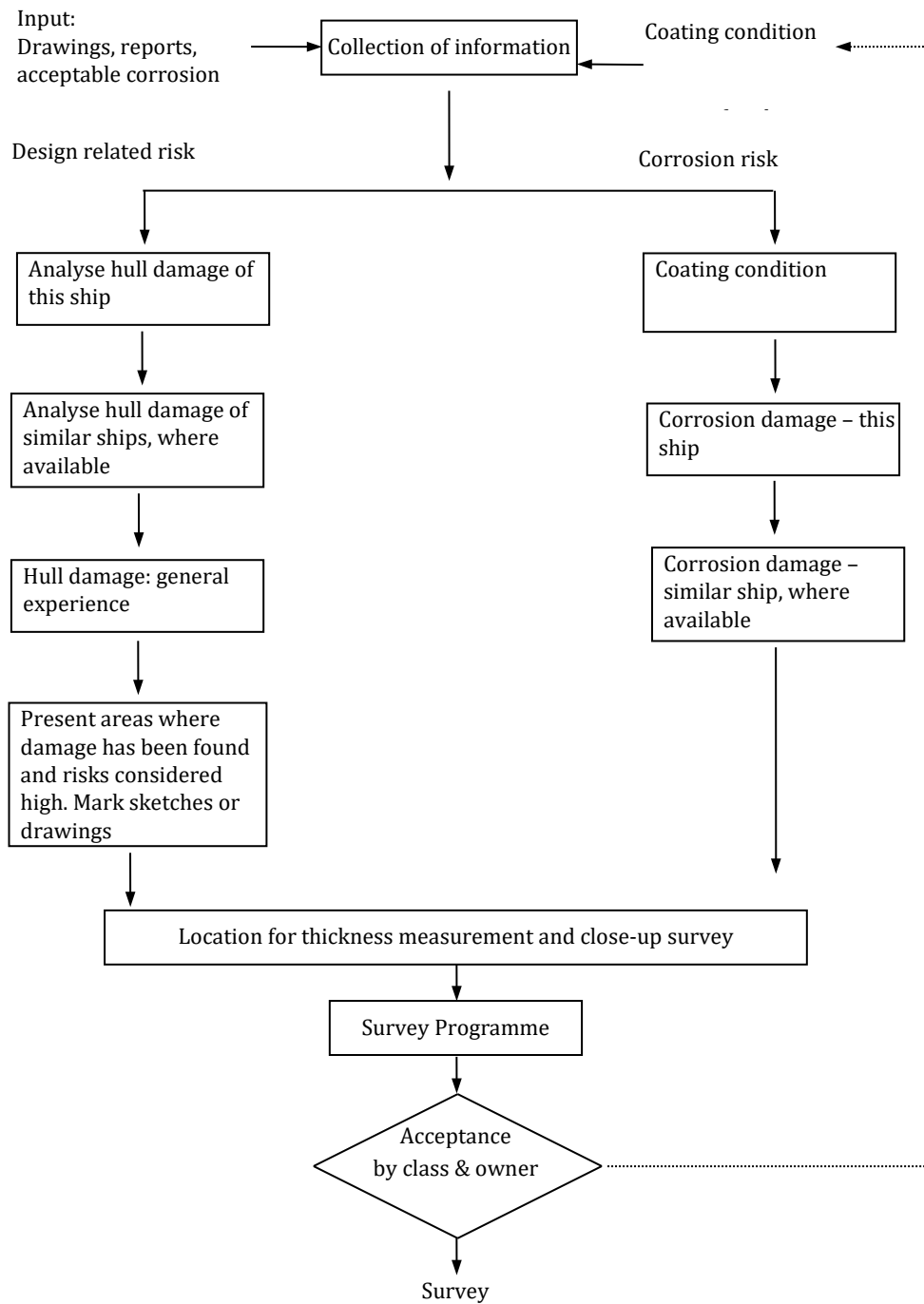

Fig. 1. Technical assessment and the survey planning process

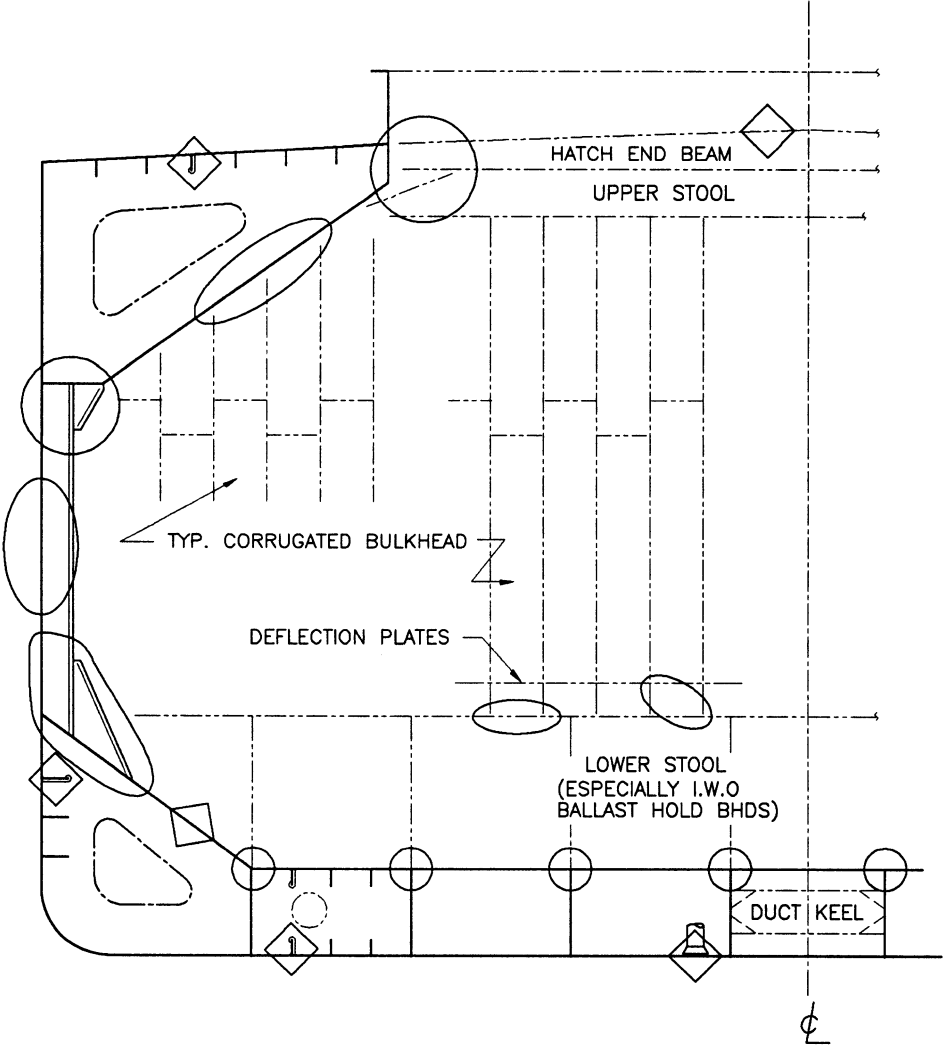

Fig. 2. Typical locations susceptible to structural damage or corrosion

AREA 1	Structural item	Side shell frames and end brackets (separate bracket configuration)	EXAMPLE 1
Detail of damage		Fractures in brackets at termination of frame	
<p>Sketch of damage</p>  <p>Separate bracket configuration</p>		<p>Sketch of repair</p>  <p>S = Snipped end</p>	
<p>Notes on possible cause of damage</p> <p>1. This type of damage is due to stress concentration.</p>		<p>Notes on repairs</p> <ol style="list-style-type: none"> 1. For small fractures, e.g. hairline fractures, the fracture can be 'veed' out, welded up, ground and examined by NDT for fractures. 2. For larger/significant fractures consideration is to be given to cropping and partly renewing/renewing the frame brackets. If renewing the brackets, ends of frames can be snipped to soften them. 3. If felt prudent, soft toes are to be incorporated at the boundaries of the bracket to the wing tanks. 4. Attention to be given to the structure in wing tanks in way of the extended bracket arm, i.e. reinforcement provided in line with the bracket arm. 	

Fig. 3. Typical damage and repair example (Reproduced from Ref. 4)

Annex II

RECOMMENDED PROCEDURES FOR THICKNESS MEASUREMENTS OF BULK CARRIERS

1. This, not mandatory document shall be used for recording the thickness measurements as required by Table II of the present *Publication*.
2. Reporting forms TM1-BC, TM2-BC, TM3-BC, TM4-BC, TM5-BC, TM6-BC, TM7-BC and TM7-BC S31 (pages 65 to 82) shall be used for recording thickness measurements and the maximum allowable diminution shall be stated. The maximum allowable diminution could be stated in an attached document.
3. The remaining pages (Sheet 1, 2 and 3) are guidance diagrams and notes relating to the reporting forms and the procedure for thickness measurement.
4. The reporting forms shall where appropriate, be supplemented by data presented on structural sketches.

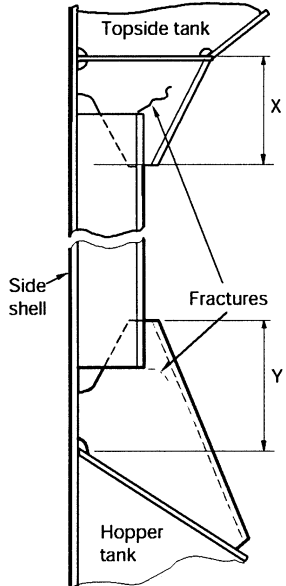
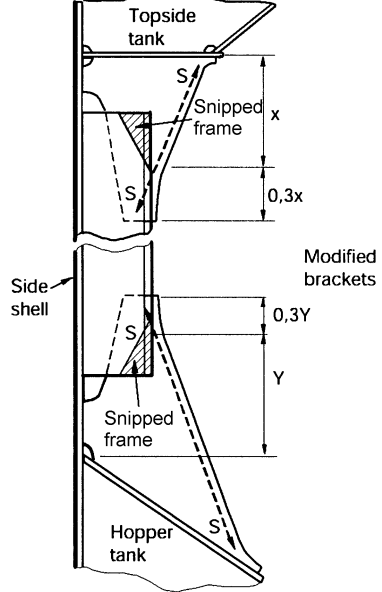
CONTENTS:

General particulars (page 64).

REPORTING FORMS

- TM1-BC Report on thickness measurement of all deck plating, all bottom shell plating or side shell plating (pages 65/66)
- TM2-BC(I) Report on thickness measurement of shell and deck plating (one, two or three transverse sections) – Strength deck and sheerstrake plating (pages 67/68)
- TM2-BC(II) Report on thickness measurement of shell and deck plating (one, two or three transverse sections) – Shell plating (pages 69/70)
- TM3-BC Report on thickness measurement of longitudinal members (one, two or three transverse sections) (pages 71/72)
- TM4-BC Report on thickness measurement of transverse structural members (pages 73/74)
- TM5-BC Report on thickness measurement of cargo hold transverse bulkheads (pages 75/76)
- TM6-BC Report on thickness measurement of miscellaneous structural members (pages 77/78)
- TM7-BC Report on thickness measurement of cargo hold transverse frames (pages 79/80)
- TM7-BC S31 for recording thickness measurements of cargo hold side shell frames under *Publication 63/P – Replacement Criteria for Side Shell Frames and Brackets in Single Side Skin Bulk Carriers and Oil-Bulk-Ore Carriers* (pages 81/82)

GUIDANCE DIAGRAMS AND NOTES

- Thickness measurement – bulk carriers. Typical transverse section indicating longitudinal and transverse members (page 83)
- Thickness measurement – bulk carriers. Transverse section outline (page 84)
- Close-up survey and thickness measurement areas (page 85).

GENERAL PARTICULARS

Ship's name:

IMO number:

PRS reg. No.:

Port of registry:

Gross tonnage:

Deadweight:

Date of build:

Classification society:

Name of Firm performing thickness measurement:

Thickness measurement firm certified by:

Certificate No:

Certificate valid from to

Place of measurement:

First date of measurement:

Last date of measurement:

Class Renewal Survey/Intermediate Survey* due:

Details of measurement equipment:

Qualification of operator:

Report number: consisting of sheets

Name of operator: Name of surveyor:

Signature of operator: Signature of surveyor:

Firm official stamp: PRS official stamp:

Notes:

* Delete as appropriate.

TM1-BC **Report on THICKNESS MEASUREMENT of ALL DECK PLATING, ALL BOTTOM SHELL PLATING or SIDE SHELL PLATING**(* - delete as appropriate)

Ship's name PRS reg. No. Report No.

STRAKE POSITION																		
	PLATE POSITION	No. or letter	Org. thick. mm	Forward reading						Aft reading						Mean diminution %		Maximum allowable diminution mm
				Gauged		Diminution P		Diminution S		Gauged		Diminution P		Diminution S		P	S	
			P	S	mm	%	mm	%	P	S	mm	%	mm	%				
12 th forward																		
11 th																		
10 th																		
9 th																		
8 th																		
7 th																		
6 th																		
5 th																		
4 th																		
3 rd																		
2 nd																		
1 st																		
Amidships																		
1 st aft																		
2 nd																		
3 rd																		
4 th																		
5 th																		
6 th																		
7 th																		
8 th																		
9 th																		
10 th																		
11 th																		
12 th																		

Operator's signature

NOTES - see overleaf



NOTES

to the report sheet TM1-BC

1. This report shall be used for recording the thickness measurement of:
 - A – All strength deck plating within the cargo length area.
 - B – Keel, bottom shell plating and bilge plating within the cargo length area.
 - C – Side shell plating that is all wind and water strakes within the length cargo area.
 - D – Side shell plating that is selected wind and water strakes outside the cargo length area.
2. The strake position shall be clearly indicated as follows:
 - 2.1 For strength deck, indicate the number of the strake of plating inboard from the stringer plate.
 - 2.2 For bottom plating, indicate the number of the strake of plating outboard from the keel plate.
 - 2.3 For side shell plating, give number of the strake of plating below sheerstrake and letter as shown on shell expansion.
3. Only the deck plating strakes outside line of openings shall be recorded.
4. Measurements shall be taken at the forward and aft areas of all plates and the single measurements recorded shall represent the average of multiple measurements.
5. The maximum allowable diminution could be stated in an attached document.

TM2-BC (I) **Report on THICKNESS MEASUREMENT of SHELL AND DECK PLATING (one, two or three transverse sections)**

Ship's name PRS reg. No. Report No.

STRENGTH DECK AND SHEERSTRAKE PLATING																												
STRAKE POSITION	FIRST TRANSVERSE SECTION AT FRAME NUMBER								SECOND TRANSVERSE SECTION AT FRAME NUMBER								THIRD TRANSVERSE SECTION AT FRAME NUMBER											
	No. or letter	Org. thick.	Max. alwb. dim.	Gauged		Diminution P		Diminution S		No. or letter	Org. thick.	Max. alwb. dim.	Gauged		Diminution P		Diminution S		No. or letter	Org. thick.	Max. alwb. Dim.	Gauged		Diminution P		Diminution S		
				P	S	mm	%	mm	%				mm	%	mm	%	mm	%				mm	%	mm	%	mm	%	
Stringer plate																												
1 st strake inboard																												
2 nd																												
3 rd																												
4 th																												
5 th																												
6 th																												
7 th																												
8 th																												
9 th																												
10 th																												
11 th																												
12 th																												
13 th																												
14 th																												
centre strike																												
sheer strike																												
TOPSIDE TOTAL																												

Operator's signature

NOTES - see overleaf



NOTES

to the report sheet TM2-BC(I)

1. This report shall be used for recording the thickness measurement of strength deck plating and sheerstrake plating transverse sections:
Two or three sections within the cargo length area, comprising the structural items (1), (2) and (3) as shown on the diagram of typical transverse section.
2. Only the deck plating strakes outside the line of openings shall be recorded.
3. The topside area comprises deck plating, stringer plate and sheerstrake (including rounded gunwales).
4. The exact frame station of measurement shall be stated.
5. The single measurements recorded shall represent the average of multiple measurements.
6. The maximum allowable diminution could be stated in an attached document.

TM2-BC (II) **Report on THICKNESS MEASUREMENT of SHELL AND DECK PLATING (one, two or three transverse sections)**

Ship's name PRS reg. No. Report No.

SHELL PLATING																											
STRAKE POSITION	FIRST TRANSVERSE SECTION AT FRAME NUMBER										SECOND TRANSVERSE SECTION AT FRAME NUMBER								THIRD TRANSVERSE SECTION AT FRAME NUMBER								
	No. or letter	Org. thick.	Max. alwb. dim.	Gauged		Diminution P		Diminution S		No. or letter	Org. thick.	Max. alwb. dim.	Gauged		Diminution P		Diminution S		No. or letter	Org. thick.	Max. alwb. Dim.	Gauged		Diminution P		Diminution S	
				P	S	mm	%	mm	%				P	S	mm	%	mm	%				P	S	mm	%	mm	%
1 st below sheer strake																											
2 nd																											
3 rd																											
4 th																											
5 th																											
6 th																											
7 th																											
8 th																											
9 th																											
10 th																											
11 th																											
12 th																											
13 th																											
14 th																											
15 th																											
16 th																											
17 th																											
18 th																											
19 th																											
20 th																											
keel strake																											
BOTTOM TOTAL																											

Operator's signature

NOTES - see overleaf



NOTES

to the report sheet TM2-BC(II)

1. This report shall be used for recording the thickness measurement of shell plating transverse sections:

Two or three sections within the cargo length area comprising the structural items (4), (5), (6) and (7) as shown on the diagram of typical transverse section.
2. The bottom area comprises keel, bottom and bilge plating.
3. The exact frame station of measurement shall be stated.
4. The single measurements recorded shall represent the average of multiple measurements.
5. The maximum allowable diminution could be stated in an attached document.

TM3-BC **Report on THICKNESS MEASUREMENT of LONGITUDINAL MEMBERS (one, two or three transverse sections)**

Ship's name PRS reg. No. Report No.

STRUCTURAL MEMBERS	FIRST TRANSVERSE SECTION AT FRAME NUMBER									SECOND TRANSVERSE SECTION AT FRAME NUMBER									THIRD TRANSVERSE SECTION AT FRAME NUMBER										
	Item No.	Org. thick.	Max. alwb. dim.	Gauged		Diminution P		Diminution S		Item No.	Org. thick.	Max.al wb. dim.	Gauged		Diminution P		Diminution S		Item No.	Org. thick.	Max. alwb. Dim.	Gauged		Diminution P		Diminution S			
				P	S	mm	%	mm	%				mm	mm	P	S	mm	%				mm	%	mm	mm	P	S	mm	%

Operator's signature

NOTES – see overleaf



NOTES

to the report sheet TM3-BC

1. This report shall be used for recording the thickness measurement of longitudinal members at transverse sections:

Two or three sections within the cargo length area, comprising the structural items (8) to (20) as shown on the diagram of typical transverse section.
2. The exact frame station of measurement shall be stated.
3. The single measurements recorded shall represent the average of multiple measurements.
4. The maximum allowable diminution could be stated in an attached document.

TM4-BC

**Report on THICKNESS MEASUREMENT of TRANSVERSE STRUCTURAL MEMBERS
in the double bottom, hopper side and topside water ballast tanks**

Ship's name PRS reg. No. Report No.

TANK DESCRIPTION:									
LOCATION OF STRUCTURE:									
STRUCTURAL MEMBER	ITEM	Original thickness	Max. alwb. dim.	Gauged		Diminution P		Diminution S	
		mm	mm	P	S	mm	%	mm	%

Operator's signature

NOTES – see overleaf



NOTES

to the report sheet TM4-BC

1. This report form shall be used for recording the thickness measurement of transverse structural members, comprising the appropriate structural items (23) to (25) as shown on diagram of typical transverse section, page 83 of this document.
2. Guidance for areas of measurement is indicated on the diagrams shown on page 85 of this document.
3. The single measurements recorded shall represent the average of multiple measurements.
4. The maximum allowable diminution could be stated in an attached document.

TM5-BC

Report on THICKNESS MEASUREMENT of CARGO HOLD TRANSVERSE BULKHEADS

Ship's name PRS reg. No. Report No.

LOCATION OF STRUCTURE:		FRAME NO.:						
STRUCTURAL COMPONENT (PLATING/STIFFENER)	Original thickness	Max. alwb. Dim.	Gauged		Diminution P		Diminution S	
	mm	mm	Port	Starboard	mm	%	mm	%

Operator's signature

NOTES – see overleaf



NOTES

to the report sheet TM5-BC

1. This report form shall be used for recording the thickness measurement of cargo hold transverse bulkheads.
2. Guidance for areas of measurement is indicated on the diagrams shown on page 85 of this document.
3. The single measurements recorded shall represent the average of multiple measurements.
4. The maximum allowable diminution could be stated in an attached document.

TM6-BC

Report on THICKNESS MEASUREMENT of MISCELLANEOUS STRUCTURAL MEMBERS

Ship's name PRS reg. No. Report No.

STRUCTURAL MEMBER:							SKETCH		
LOCATION OF STRUCTURE:									
Description	Org. thick.	Max. alwb. dim.	Gauged		Diminution P		Diminution S		
	mm		mm	P	S	mm	%	mm	

Operator's signature

NOTES – see overleaf



NOTES

to the report sheet TM6-BC

1. This report shall be used for recording the thickness measurement of miscellaneous structural members including the structural items (28), (29), (30) and (31) as shown on diagram of typical transverse section, page 83 of this document.
2. Guidance for areas of measurement is indicated on the diagrams shown on page 85 of this document.
3. The single measurements recorded shall represent the average of multiple measurements.
4. The maximum allowable diminution could be stated in an attached document.

TM7-BC

Report on THICKNESS MEASUREMENT of CARGO HOLD TRANSVERSE FRAMES

Ship's name PRS reg. No. Report No.

CARGO HOLD NO.																								
FRAME NUMBER	UPPER PART								MID PART								LOWER PART							
	Org. thick.	Max. alwb. Dim.	Gauged		Diminution P		Diminution S		Org. thick.	Max. alwb. Dim.	Gauged		Diminution P		Diminution S		Org. thick.	Max. alwb. dim.	Gauged		Diminution P		Diminution S	
	mm	mm	P	S	mm	%	mm	%	mm	mm	P	S	mm	%	mm	%	mm	mm	P	S	mm	%	mm	%

Operator's signature

NOTES - see overleaf



NOTES

to the report sheet TM7-BC

1. This report shall be used for recording the thickness measurement of cargo hold transverse frames:
Structural item number 34 as shown on the diagram of typical transverse section, page 83 of this document.
2. Guidance for areas of measurement is indicated on the diagrams shown on page 85 of this document.
3. The single measurements recorded shall represent the average of multiple measurements.
4. The location and pattern of measurements shall be indicated on the sketches of hold frames shown below.

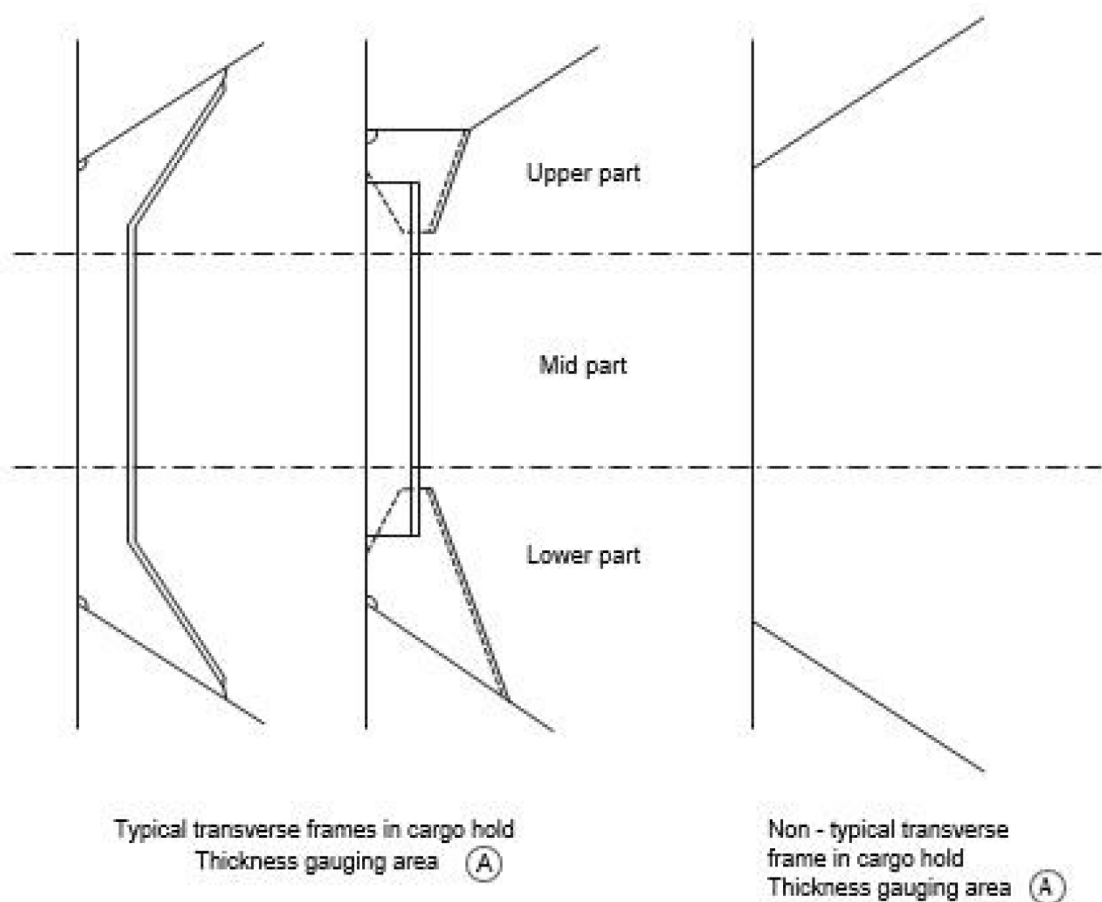

5. The maximum allowable diminution could be stated in an attached document.

TM7-BC S31

REPORT on THICKNESS MEASUREMENT of CARGO HOLD SIDE SHELL FRAMES

Ship's name PRS reg. No..... Report No.

FRAME NUMBER	ZONE A						ZONE B						ZONE C						ZONE D					
	Orig. thick.	T_{REN}	t_{COAT}	t_M	Diminution		Orig. thick.	T_{REN}	t_{COAT}	t_M	Diminution		Orig. thick.	T_{REN}	t_{COAT}	t_M	Diminution		Orig. thick.	t_{REN}	t_{COAT}	t_M	Diminution	
	mm	mm	mm	mm	mm	%	mm	mm	mm	mm	mm	%	mm	mm	mm	mm	mm	%	mm	mm	mm	mm	mm	%

Operator's signature

NOTES see overleaf



NOTES

to report sheet TM7-BC S31

1. This report shall be used for recording the thickness measurement of Cargo Hold Transverse Frames for application of *Publication 63/P – Renewal Criteria for Side Shell Frames and Brackets in Single Side Skin Bulk Carriers and Oil-Bulk-Ore Carriers*.
2. Guidance for the areas of measurement is contained in Annex V.
3. The maximum allowable diminution could be stated in an attached document.

Thickness measurement – bulk carriers

Typical transverse section indicating longitudinal and transverse members

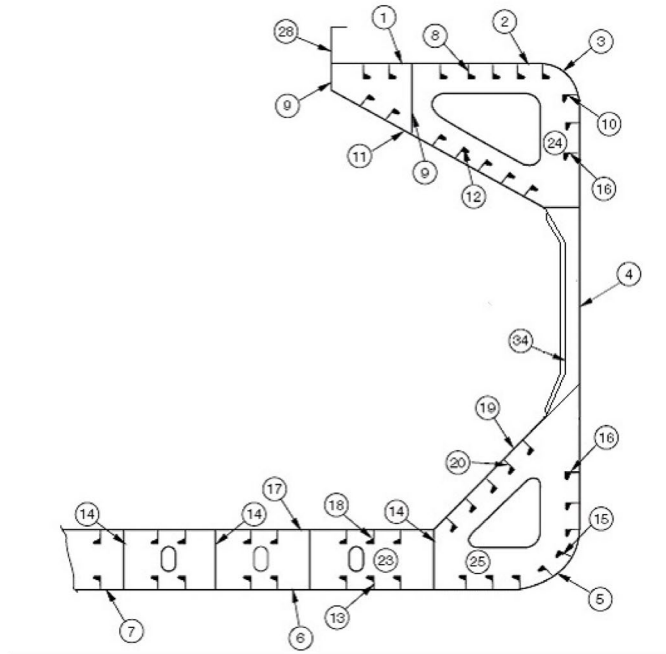

Report on TM2	Report on TM3-BC	
(1) Strength deck plating	(8) Deck longitudinals	(16) Side shell longitudinals
(2) Stringer plate	(9) Deck girders	(17) Inner bottom plating
(3) Sheerstrake	(10) Sheerstrake longitudinals	(18) Inner bottom longitudinals
(4) Side shell plating	(11) Topside tank sloping plating	(19) Hopper side plating
(5) Bilge plating	(12) Topside tank sloping plating longitudinals	(20) Hopper side longitudinals
(6) Bottom shell plating	(13) Bottom longitudinals	(21)
(7) Keel plate	(14) Bottom girders	(22)
	(15) Bilge Longitudinals	

Report on TM4	Report on TM6-BC	Report on TM7-BC
(23) Double bottom tank floors	(28) Hatch coamings	(34) Hold frames or diaphragms
(24) Topside tank transverse members	(29) Deck plating between hatches	
(25) Hopper side tank transverse members	(30) Hatch covers	
(26)	(31)	
(27)	(32)	
	(33)	

Thickness measurement – bulk carriers

Transverse section outline

To be used for longitudinal and transverse members where the typical bulk carrier section is not applicable

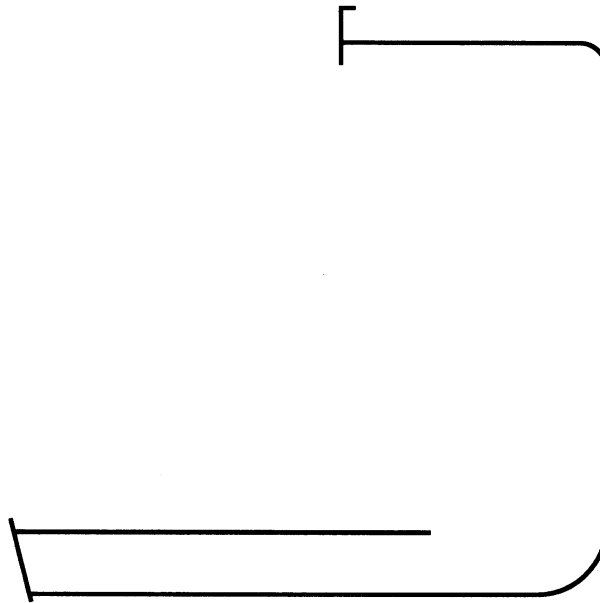

REPORT ON TM2-BC	
①	Strength deck plating
②	Stringer plate
③	Sheerstrake
④	Side shell plating
⑤	Bilge plating
⑥	Bottom shell plating
⑦	Keel plate

REPORT ON TM3-BC			
⑧	Deck longitudinals	⑩⑥	Side shell longitudinals
⑨	Deck girders	⑩⑦	Inner bottom plating
⑩	Sheerstrake longitudinals	⑩⑧	Inner bottom longitudinals
⑪	Topside tank sloping plating	⑩⑨	Hopper side plating
⑫	Topside tank sloping plating longitudinals	⑩⑩	Hopper side longitudinals
⑬	Bottom longitudinals	⑩⑪	
⑭	Bottom girders	⑩⑫	
⑮	Bilge longitudinals	⑩⑬	

REPORT ON TM4-BC	
⑮③	Double bottom tank floors
⑮④	Topside tank transverses
⑮⑤	Hopper side tank transverses
⑮⑥	
⑮⑦	

REPORT ON TM6-BC	
⑮⑧	Hatch coamings
⑮⑨	Deck plating between hatches
⑮⑩	Hatch covers
⑮⑪	Inner bulkhead plating
⑮⑫	
⑮⑬	

REPORT ON TM7-BC	
⑮⑭	Hold frames or diaphragms

Close-up Survey and Thickness Measurement Areas

Typical transverse section

Areas (A), (B) and (D)

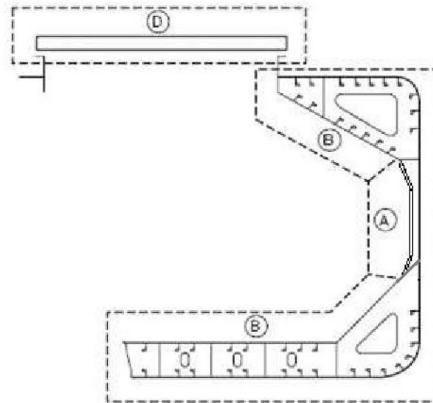

Thickness to be reported on TM3-BC, TM4-BC, TM6-BC and TM7-BC as appropriate

A cargo hold, transverse bulkhead

Area (C)

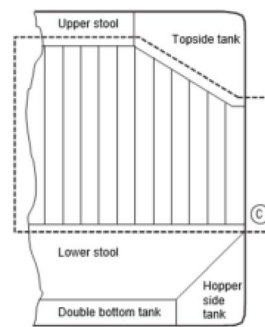

Thickness to be reported on TM5-BC

Typical areas of deck plating inside line of hatch openings between cargo hold hatches

Area (E)

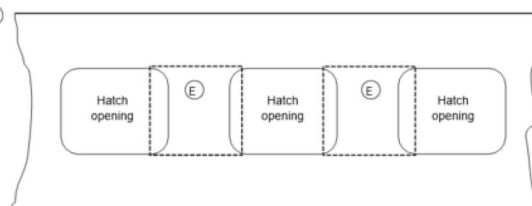

Thickness to be reported on TM6-BC

Annex II (CSR)**RECOMMENDED PROCEDURES FOR THICKNESS MEASUREMENTS OF BULK CARRIERS BUILT UNDER CSR**

1. This, not mandatory document, shall be used for recording the thickness measurements of bulk carriers built under CSR as required by Table II of the present *Publication*.
2. Reporting forms TM1-BC(CSR), TM2-BC(CSR) (I) and (II), TM3-BC(CSR), TM4-BC(CSR), TM5-BC(CSR), TM6-BC(CSR) and TM7-BC(CSR) (pages 88 to 103) shall be used for recording thickness measurements. The as-built thickness and the voluntary thickness addition and renewal thickness (minimum allowable thickness) shall be stated in an attached document.
3. The remaining pages (Sheet 1, 2 and 3) are guidance diagrams and notes relating to the reporting forms and the procedure for thickness measurement.

Contents:

General particulars (page 87).

REPORTING FORMS

- TM1-BC(CSR) Report on thickness measurement of all deck plating, all bottom shell plating and side shell plating (pages 88/89)
- TM2-BC(CSR)(I) Report on thickness measurement of shell and deck plating at transverse sections – strength deck and sheerstrake plating (pages 90/91)
- TM2-BC(CSR)(II) Report on thickness measurement of shell plating at three transverse sections (pages 92/93)
- TM3-BC(CSR) Report on thickness measurement of longitudinal members at transverse sections (pages 94/95)
- TM4-BC(CSR) Report on thickness measurement of transverse structural members (pages 96/97)
- TM5-BC(CSR) Report on thickness measurement of cargo hold transverse bulkheads (pages 98/99)
- TM6-BC(CSR) Report on thickness measurement of miscellaneous structural members (pages 100/101)
- TM7-BC(CSR) Report on thickness measurement of cargo hold transverse frames (pages 102/103)

GUIDANCE DIAGRAMS AND NOTES

- Typical transverse section of bulk carrier. The diagram includes details of the items to be measured and the report forms to be used.(page 104)
- Transverse section outline. This diagram may be used for those ships where diagram on page 104 is not suitable.
- Sketches of bulk carrier showing typical areas for thickness measurement of cargo hold frames, structural members and transverse bulkheads in association with close-up survey requirements (page 106).

General particulars

Ship's name:

IMO number:

PRS reg. No.:

Port of registry:

Gross tonnage:

Deadweight:

Date of build:

Classification society:

Name of Firm performing thickness measurement:

Thickness measurement firm certified by:

Certificate No:

Certificate valid from to

Place of measurement:

First date of measurement:

Last date of measurement:

Class Renewal Survey/Intermediate Survey* due:

Details of measurement equipment:

Qualification of operator:

Report number: consisting of sheets

Name of operator: Name of surveyor:

Signature of operator: Signature of Surveyor:

Firm official stamp: PRS official stamp:

Notes:

* Delete as appropriate.



TM1-BC(CSR) **Report on THICKNESS MEASUREMENT of ALL DECK PLATING, ALL BOTTOM SHELL PLATING or SIDE SHELL PLATING*** (* - delete as appropriate)

Ship's name PRS reg. No. Report No.

STRAKE POSITION																
PLATE POSITION	No. or letter	As built	Volunt.	Ren.	Forward reading				Aft reading				Mean Remaining			
		Thk.	Thk. Addit.	Thick.	Gauged Thk. Mm (b1)		Remaining Corr. Addition, mm (c1) = (b1) - (a)		Gauged Thk. Mm (b2)		Remaining Corr. Addition, mm (c2) = (b2) - (a)		Corr. Addition, mm [(c1) + (c2)]/2			
		mm	mm	mm	P	S	P	S	P	S	P	S	P	S		
12 th forward																
11 th																
10 th																
9 th																
8 th																
7 th																
6 th																
5 th																
4 th																
3 rd																
2 nd																
1 st																
Amidships																
1 st aft																
2 nd																
3 rd																
4 th																
5 th																
6 th																
7 th																
8 th																
9 th																
10 th																
11 th																
12 th																

Operator's signature

NOTES - see next page



NOTES

to the report sheet TM1-BC (CSR)

1. This report shall be used for recording the thickness measurement of:
 - A – All strength deck plating within the cargo length area.
 - B – Keel, bottom shell plating and bilge plating within the cargo length area.
 - C – Side shell plating that is all wind and water strakes within the length cargo area.
 - D – Side shell plating that is selected wind and water strakes outside the cargo length area.
2. The strake position shall be clearly indicated as follows:
 - 2.1 For strength deck, indicate the number of the strake of plating inboard from the stringer plate.
 - 2.2 For bottom plating, indicate the number of the strake of plating outboard from the keel plate.
 - 2.3 For side shell plating, give number of the strake of plating below sheerstrake and letter as shown on shell expansion.
3. Only the deck plating strakes outside line of openings shall be recorded.
4. Measurements shall be taken at the forward and aft areas of all plates and the single measurements recorded shall represent the average of multiple measurements.
5. The remaining corrosion addition shall be recorded with result of gauged thickness minus renewal thickness. If the result is negative, the structure in way shall be renewed, and the mark "R" shall be indicated in the right-hand column. If the result is between 0 and 0.5 mm (0 included), the structure in way shall be additional gauged, and the mark "S" shall be indicated in the right-hand column.

TM2-BC(CSR) (I) **Report on THICKNESS MEASUREMENT of SHELL AND DECK PLATING (one, two or three transverse sections)**

Ship's name PRS reg. No. Report No.

STRENGTH DECK AND SHEERSTRAKE PLATING																														
STRAKE POSITION	FIRST TRANSVERSE SECTION AT FRAME NUMBER								SECOND TRANSVERSE SECTION AT FRAME NUMBER								THIRD TRANSVERSE SECTION AT FRAME NUMBER													
	No. or letter	As Built Thk	Vol. Thk. Add mm	Ren. Thk. mm (a)	Gauged Thk., mm (b)		Remaining Corr. Addition, mm (b) - (a)		No. or letter	As Built Thk.	Vol. Thk. Add mm	Ren. Thk. mm (a)	Gauged Thk., mm (b)		Remaining Corr. Addition, mm (b) - (a)		No. or letter	As Built Thk. Mm	Vol. Thk. Add. Mm	Ren. Thk. mm (a)	Gauged Thk.,mm (b)		Remaining Corr. Addition, mm (b) - (a)							
					P	S	P	S					P	S	P	S					P	S	P	S						
Stringer plate																														
1 st strake inboard																														
2 nd																														
3 rd																														
4 th																														
5 th																														
6 th																														
7 th																														
8 th																														
9 th																														
10 th																														
11 th																														
12 th																														
13 th																														
14 th																														
centre strike																														
sheer strike																														
TOPSIDE TOTAL																														

Operator's signature

NOTES - see next page



NOTES

to the report sheet TM2-BC(CSR)(I)

1. This report shall be used for recording the thickness measurement of strength deck plating and sheerstrake plating transverse sections:

Two or three sections within the cargo length area, comprising the structural items (1), (2) and (3) as shown on the diagram of typical transverse section.
2. Only the deck plating strakes outside the line of openings shall be recorded.
3. The topside area comprises deck plating, stringer plate and sheerstrake (including rounded gunwales).
4. The exact frame station of measurement shall be stated.
5. The single measurements recorded shall represent the average of multiple measurements.
6. The remaining corrosion addition shall be recorded with result of gauged thickness minus renewal thickness. If the result is negative, the structure in way shall be renewed, and the mark "R" shall be indicated in the right-hand column. If the result is between 0 and 0.5 mm (0 included), the structure in way shall be additional gauged, and the mark "S" shall be indicated in the right-hand column.

TM2-BC(CSR) (II) **Report on THICKNESS MEASUREMENT of SHELL AND DECK PLATING (one, two or three transverse sections)**

Ship's name PRS reg. No. Report No.

SHELL PLATING																								
STRAKE POSITION	FIRST TRANSVERSE SECTION AT FRAME NUMBER						SECOND TRANSVERSE SECTION AT FRAME NUMBER						THIRD TRANSVERSE SECTION AT FRAME NUMBER											
	No. or letter	As Built Thk. Mm	Vol. Thk. Add. Mm	Ren. Thk. mm (a)	Gauged Thk, mm (b)		Remaining Corr. Addition, mm (b) - (a)		No. or letter	As Built Thk. Mm	Vol. Thk. Add. Mm	Ren. Thk. mm (a)	Gauged Thk, mm (b)		Remaining Corr. Addition, mm (b) - (a)		No. or letter	As Built Thk. Mm	Vol. Thk. Add. Mm	Ren. Thk. mm (a)	Gauged Thk, mm (b)		Remaining Corr. Addition, mm (b) - (a)	
					P	S	P	S					P	S	P	S					S	P	P	S
					P	S	P	S					P	S	S	P					P	S		
1 st below sheer strake																								
2 nd																								
3 rd																								
4 th																								
5 th																								
6 th																								
7 th																								
8 th																								
9 th																								
10 th																								
11 th																								
12 th																								
13 th																								
14 th																								
15 th																								
16 th																								
17 th																								
18 th																								
19 th																								
20 th																								
keel strake																								
BOTTOM TOTAL																								

Operator's signature

NOTES - see next page



NOTES

to the report sheet TM2-BC(CSR)(II)

1. This report shall be used for recording the thickness measurement of shell plating transverse sections:

Two or three sections within the cargo length area comprising the structural items (4), (5), (6) and (7) as shown on the diagram of typical transverse section.

2. The bottom area comprises keel, bottom and bilge plating.
3. The exact frame station of measurement shall be stated.
4. The single measurements recorded shall represent the average of multiple measurements.
5. The remaining corrosion addition shall be recorded with result of gauged thickness minus renewal thickness. If the result is negative, the structure in way shall be renewed, and the mark "R" shall be indicated in the right-hand column. If the result is between 0 and 0.5 mm (0 included), the structure in way shall be additional gauged, and the mark "S" shall be indicated in the right-hand column.

TM3-BC (CSR) **Report on THICKNESS MEASUREMENT of LONGITUDINAL MEMBERS (one, two or three transverse sections)**

Ship's name PRS reg. No. Report No.

STRUCTU- RAL MEMBERS	FIRST TRANSVERSE SECTION AT FRAME NUMBER							SECOND TRANSVERSE SECTION AT FRAME NUMBER							THIRD TRANSVERSE SECTION AT FRAME NUMBER													
	Item No.	As Built Thk. Mm	Vol. Thk. Add. Mm	Ren. Thk. mm (a)	Gauged Thk, mm (b)		Remaining Corr. Addition, mm (b) - (a)		Item No.	As Built Thk. Mm	Vol. Thk. Add. Mm	Ren. Thk. mm (a)	Gauged Thk, mm (b)		Remaining Corr. Addition, mm (b) - (a)		Item No.	As Built Thk. Mm	Vol. Thk. Add. Mm	Ren. Thk. mm (a)	Gauged Thk, mm (b)		Remaining Corr. Addition, mm (b) - (a)					
					P	S	P	S					P	S	P	S					P	S	P	S	P	S		

Operator's signature

NOTES – see next page



NOTES

to the report sheet TM3-BC(CSR)

1. This report shall be used for recording the thickness measurement of longitudinal members at transverse sections:

Two or three sections within the cargo length area, comprising the structural items (8) to (20) as shown on the diagram of typical transverse section.
2. The exact frame station of measurement shall be stated.
3. The single measurements recorded shall represent the average of multiple measurements.
4. The remaining corrosion addition shall be recorded with result of gauged thickness minus renewal thickness. If the result is negative, the structure in way shall be renewed, and the mark "R" shall be indicated in the right-hand column. If the result is between 0 and 0.5 mm (0 included), the structure in way shall be additional gauged, and the mark "S" shall be indicated in the right-hand column.

TM4-BC(CSR)

**Report on THICKNESS MEASUREMENT of TRANSVERSE STRUCTURAL MEMBERS
in the double bottom, hopper side and topside water ballast tanks**

Ship's name PRS reg. No. Report No.

TANK DESCRIPTION:										
LOCATION OF STRUCTURE:										
STRUCTURAL MEMBER	ITEM	As Built Thickness mm	Voluntary Thickness Addition mm	Renewal Thickness mm (a)	Gauged Thickness, mm (b)		Remaining Corr. Addition, mm (b) - (a)			
					P	S	P		S	

Operator's signature

NOTES - see next page



NOTES

to the report sheet TM4-BC(CSR)

1. This report form shall be used for recording the thickness measurement of transverse structural members, comprising the appropriate structural items (23) to (25) as shown on diagram of typical transverse section, page 104 of the present *Publication*.
2. Guidance for areas of measurement is indicated on the diagrams shown on page 106 of the present *Publication*.
3. The single measurements recorded shall represent the average of multiple measurements.
4. The remaining corrosion addition shall be recorded with result of gauged thickness minus renewal thickness. If the result is negative, the structure in way shall be renewed, and the mark "R" shall be indicated in the right-hand column. If the result is between 0 and 0.5 mm (0 included), the structure in way shall be additional gauged, and the mark "S" shall be indicated in the right-hand column.

TM5-BC(CSR)

Report on THICKNESS MEASUREMENT of CARGO HOLD TRANSVERSE BULKHEADS

Ship's name PRS reg. No. Report No.

HOLD DESCRIPTION:							
LOCATION OF STRUCTURE:				FRAME NO.:			
STRUCTURAL COMPONENT (PLATING/STIFFENER)	As Built Thickness mm	Voluntary Thickness Addition mm	Renewal Thickness mm (a)	Gauged Thickness, mm (b)		Remaining Corr. Addition, mm (b) - (a)	
				P	S	P	S

Operator's signature

NOTES – see next page



NOTES

to the report sheet TM5-BC(CSR)

1. This report form shall be used for recording the thickness measurement of cargo hold transverse bulkheads.
2. Guidance for areas of measurement is indicated on the diagrams shown on page 106 of the present *Publication*.
3. The single measurements recorded shall represent the average of multiple measurements.
4. The remaining corrosion addition shall be recorded with result of gauged thickness minus renewal thickness. If the result is negative, the structure in way shall be renewed, and the mark "R" shall be indicated in the right-hand column. If the result is between 0 and 0.5 mm (0 included), the structure in way shall be additional gauged, and the mark "S" shall be indicated in the right-hand column.

TM6-BC (CSR)

Report on THICKNESS MEASUREMENT of MISCELLANEOUS STRUCTURAL MEMBERS

Ship's name PRS reg. No. Report No.

STRUCTURAL MEMBER:							SKETCH			
LOCATION OF STRUCTURE:										
Description	As Built Thk. Mm	Voluntary Thickness Addition mm	Renewal Thk. mm (a)	Gauged Thickness, mm (b)		Remaining Corr. Addition, mm (b) - (a)				
				P	S	P	S			

Operator's signature

NOTES - see next page



NOTES

to the report sheet TM6-BC(CSR)

1. This report shall be used for recording the thickness measurement of miscellaneous structural members including the structural items (28), (29), and (30) as shown on diagram of typical transverse section, page 90 of the present *Publication*.
2. Guidance for areas of measurement is indicated on the diagrams shown on page 91 of the present *Publication*.
3. The single measurements recorded shall represent the average of multiple measurements.
4. The remaining corrosion addition shall be recorded with result of gauged thickness minus renewal thickness. If the result is negative, the structure in way shall be renewed, and the mark "R" shall be indicated in the right-hand column. If the result is between 0 and 0.5 mm (0 included), the structure in way shall be additional gauged, and the mark "S" shall be indicated in the right-hand column.

TM7-BC(CSR)

Report on THICKNESS MEASUREMENT of CARGO HOLD TRANSVERSE FRAMES

Ship's name PRS reg. No. Report No.

CARGO HOLD NO.																						
FRAME NUMBER	UPPER PART						MID PART						LOWER PART									
	As Built Thk. mm	Volun. Thk. Add. mm	Renewal Thk. mm (a)	Gauged Thickness mm (b)		Remaining Corr. Addition mm (b) - (a)		As Built Thk. mm	Volun. Thk. Add. mm	Renewal Thk. mm (a)	Gauged Thickness mm (b)		Remaining Corr. Addition mm (b) - (a)		As Built Thk. mm	Volun. Thk. Add. mm	Renewal Thk. mm (a)	Gauged Thickness mm (b)		Remaining Corr. Addition mm (b) - (a)		
				P	S	P	S				P	S	P	S				P	S			

Operator's signature

NOTES - see next page



NOTES

to the report sheet TM7-BC(CSR)

1. This report shall be used for recording the thickness measurement of cargo hold transverse frames:

Structural item number 34 as shown on the diagram of typical transverse section, page 104 of the present *Publication*.

2. Guidance for areas of measurement is indicated on the diagrams shown on page 106 of the present *Publication*.

The single measurements recorded shall represent the average of multiple measurements.

3. The location and pattern of measurements shall be indicated on the sketches of hold frames shown below.

4. The remaining corrosion addition shall be recorded with result of gauged thickness minus renewal thickness. If the result is negative, the structure in way shall be renewed, and the mark "R" shall be indicated in the right-hand column. If the result is between 0 and 0.5 mm (0 included), the structure in way shall be additional gauged, and the mark "S" shall be indicated in the right-hand column.

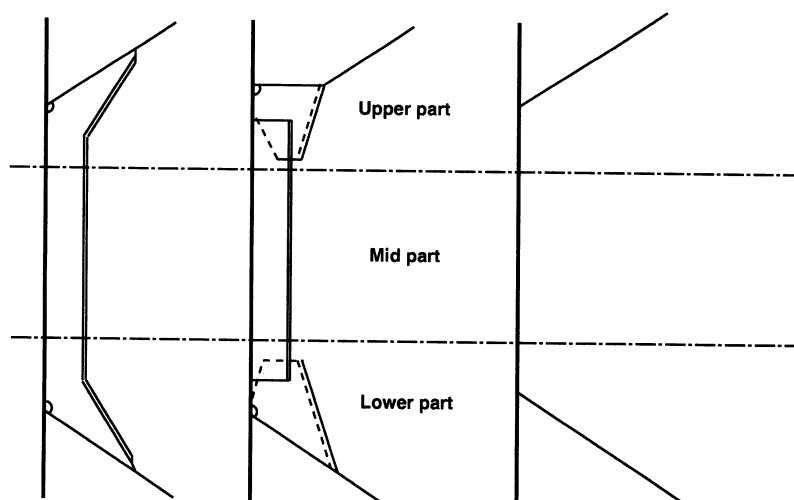

Typical transverse frames in cargo hold
Thickness gauging area (A)

Non - typical transverse
frame in cargo hold
Thickness gauging area (A)

Thickness measurement – bulk carriers

Typical transverse section indicating longitudinal and transverse members

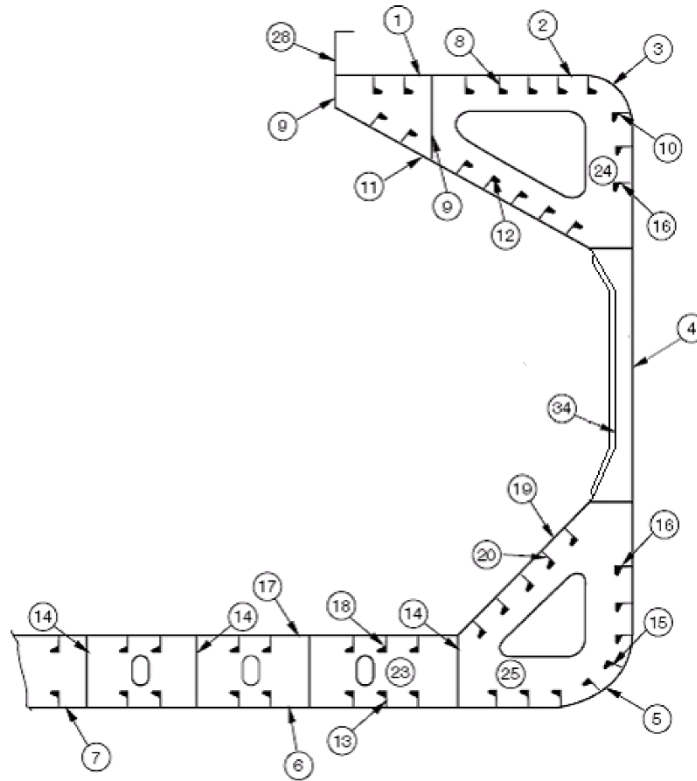

Report on TM2-BC(CSR) (i) & (ii)
1. Strength deck plating
2. Stringer plate
3. Sheerstrake
4. Side shell plating
5. Bilge plating
6. Bottom plating
7. Keel plate

Report on TM3-BC(CSR)	
8. Deck longitudinals	17. Inner bottom plating
9. Deck girders	18. Inner bottom longitudinals
10. Sheerstrake longitudinals	19. Hopper plating
11. Topside tank sloping plating	20. Hopper longitudinals
12. Topside tank sloping plating longitudinals	21.
13. Bottom longitudinals	22.
14. Bottom girders	Report on TM4-BC(CSR)
15. Bilge longitudinals	23. Double bottom tank floors
16. Side shell longitudinals, if any	24. Top side transverses
	25. Hopper side tank transverses
	26.
	27.

Report on TM6-BC(CSR)
28. Hatch coamings
29. Deck plating between hatches
30. Hatch covers
31.
32.
33.
Report on TM7-BC(CSR)
34. Cargo hold frames

Thickness measurement – bulk carriers

Transverse section outline

To be used for longitudinal and transverse members where the typical bulk carrier section is not applicable

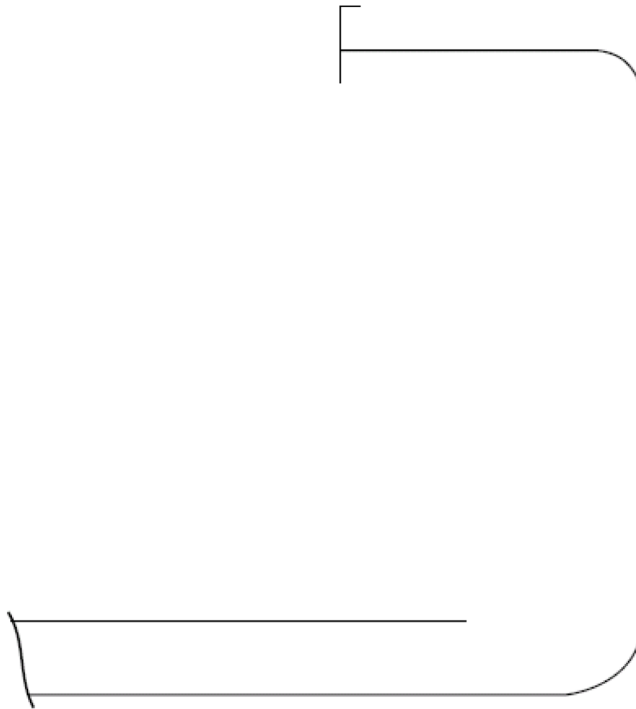

Report on TM2-BC(CSR) (i) & (ii)
1. Strength deck plating
2. Stringer plate
3. Sheerstrake
4. Side shell plating
5. Bilge plating
6. Bottom plating
7. Keel plate

Report on TM3-BC(CSR)	
8. Deck longitudinals	17. Inner bottom plating
9. Deck girders	18. Inner bottom longitudinals
10. Sheerstrake longitudinals	19. Hopper plating
11. Topside tank sloping plating	20. Hopper longitudinals
12. Topside tank sloping plating longitudinals	21.
13. Bottom longitudinals	22.
14. Bottom girders	Report on TM4-BC(CSR)
15. Bilge longitudinals	23. Double bottom tank floors
16. Side shell longitudinals, if any	24. Top side tank transverses
	25. Hopper side tank transverses
	26.
	27.

Report on TM6-BC(CSR)
28. Hatch coamings
29. Deck plating between hatches
30. Hatch covers
31.
32.
33.
Report on TM7-BC(CSR)
34. Cargo hold frames

Close-up Survey and Thickness Measurement Areas

Typical transverse section

Areas (A), (B) and (D)

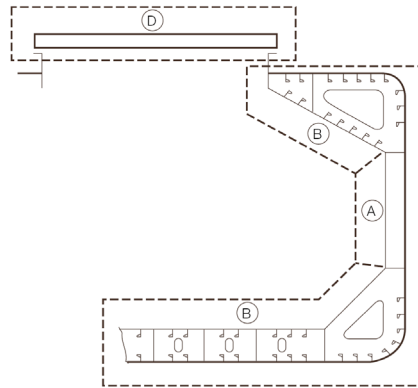

Thickness to be reported on TM3-BC, TM4-BC, TM6-BC and TM7-BC as appropriate

A cargo hold, transverse bulkhead

Area (C)

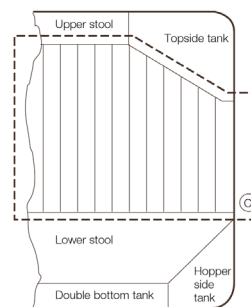

Thickness to be reported on TM5-BC

Typical areas of deck plating inside line of hatch openings between cargo hold hatches

Area (E)

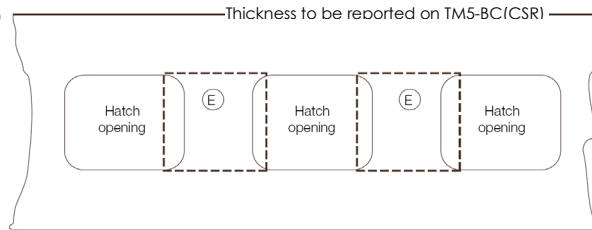

Thickness to be reported on TM6-BC

Annex III

**GUIDELINES FOR THE GAUGING OF THE VERTICALLY CORRUGATED
TRANSVERSE WATERTIGHT BULKHEAD
BETWEEN HOLDS NOS. 1 AND 2**

1. Gauging is necessary to determine the general condition of the structure and to define the extent of possible repairs and/or reinforcements of the vertically corrugated transverse watertight bulkhead for verification of the compliance with para. 2.1 of Supplement to *Part II – Hull* of the *Rules for the Classification and Construction of Sea-going Ships*.
2. Taking into account the buckling model applied in a.m. para. 2.1 in the evaluation of strength of the bulkhead, it is essential to determine the thickness diminution at the critical levels shown in Figures 1 and 2.
3. The gauging shall be performed at the levels as described below. To adequately assess the scantlings of each individual vertical corrugation, each corrugation flange, web, shedder plate and gusset plate within each of the levels given below shall be gauged.

Level (a): Ships without lower stool (see Figure 1):

Locations:

- The mid-breadth of the corrugation flanges at approximately 200 mm above the line of shedder plates;
- The middle of gusset plates between corrugation flanges, where fitted;
- The middle of the shedder plates;
- The mid-breadth of the corrugation webs at approximately 200 mm above the line of shedder plates.

Level (b): Ships with lower stool (see Figure 2):

Locations:

- The mid-breadth of the corrugation flanges at approximately 200 mm above the line of shedder plates;
- The middle of gusset plates between corrugation flanges, where fitted;
- The middle of the shedder plates;
- The mid-breadth of the corrugation webs at approximately 200 mm above the line of shedder plates.

Level I: Ships with or without lower stool (see Figures 1 and 2):

Locations:

- The mid-breadth of the corrugation flanges and webs at about the mid-height of the corrugation.

4. Where the thickness changes within the horizontal levels, the thinner plate shall be gauged.
5. Steel renewal/and or reinforcement shall fulfil a.m. para. 2.1.

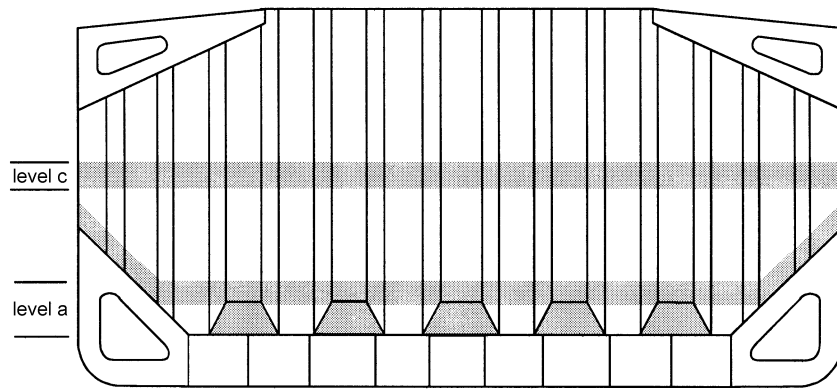

Fig. 1

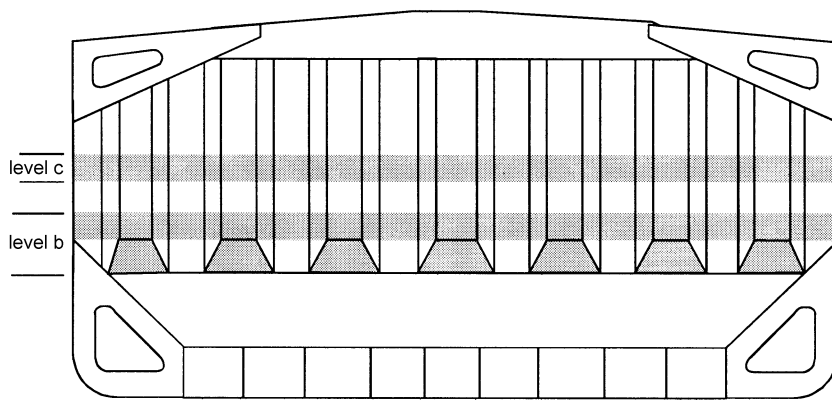

Fig. 2

Annex IV

ADDITIONAL ANNUAL SURVEY REQUIREMENTS FOR THE FOREMOST CARGO HOLD OF SHIPS SUBJECT TO SOLAS XII/9.1

1 General

1.1 In the case of bulk carrier over 5 years of age, the Annual Survey shall include, in addition to the requirements of the Annual Surveys prescribed in chapter 2 of the present *Publication*, an examination of the following items:

2 Extent of Survey

2.1 For bulk carriers of 5 – 15 years of age:

- .1** An Overall Survey of the foremost cargo hold, including Close-up Survey of sufficient extent, minimum 25% of frames, shall be performed to establish the condition of:
 - shell frames including their upper and lower attachments, adjacent shell plating, and transverse bulkheads;
 - suspect areas identified at previous surveys.
- .2** Where considered necessary by the surveyor as a result of the Overall and Close-up Survey as described in .1 above, the survey shall be extended to include a Close-up Survey of all of the shell frames and adjacent shell plating of the cargo hold.

2.2 For bulk carriers exceeding 15 years of age:

3 An overall survey of the foremost cargo hold, including close-up survey shall be performed to establish the condition of:

- all shell frames including their upper and lower end attachments, adjacent shell plating, and transverse bulkheads,
- suspect areas identified at previous surveys.

4 Extent of thickness Measurement

4.1 Thickness measurement shall be performed to an extent sufficient to determine both general and local corrosion levels at areas subject to Close-up Survey, as described in 2.1.1 and 2.2.1 above.

The minimum requirement for thickness measurements are suspect areas identified at previous surveys.

Where substantial corrosion is found, the extent of thickness measurements shall be increased in accordance with the requirements of Table VIII.

The thickness measurement may be dispensed with provided the surveyor is satisfied by the Close-up Survey, that there is no structural diminution and the protective coating where applied remains effective.

5 Special Consideration

5.1 Where the protective coating in the foremost cargo hold is found to be in GOOD condition and the requirement of p. 2.4.2, *Part II – Hull of the Rules for the Classification and Construction of Seagoing Ships* is fulfilled, the extent of Close-up Surveys and thickness measurements may be specially considered.

Explanatory note:

For existing bulk carriers, where owners may elect to coat or recoat cargo holds as noted above, consideration may be given to the extent of the close-up and thickness measurement surveys. Prior to the coating of cargo holds of existing ships, scantlings shall be ascertained in the presence of a Surveyor.

Annex V

GUIDELINES FOR THE GAUGING OF SIDE SHELL FRAMES AND BRACKETS IN SINGLE SKIN BULK CARRIERS REQUIRED TO COMPLY WITH THE REQUIREMENTS OF PUBLICATION 63/P – RENEWAL CRITERIA FOR SIDE SHELL FRAMES AND BRACKETS IN SINGLE SIDE SKIN BULK CARRIERS AND OIL-BULK-ORE CARRIERS

1 General

Gauging is necessary to determine the general condition of the structure and to define the extent of possible steel renewals or other measures for the webs and flanges of side shell frames and brackets for verification of the compliance with *Publication 63/P – Renewal Criteria for Side Shell Frames and Brackets in Single Side Skin Bulk Carriers and Oil-Bulk-Ore Carriers*.

4.2 Zones of side shell frames and brackets

For the purpose of steel renewal, sand blasting and coating, four zones A, B, C and D are defined as shown in Figure 1.

Zones A & B are considered to be the most critical zones.

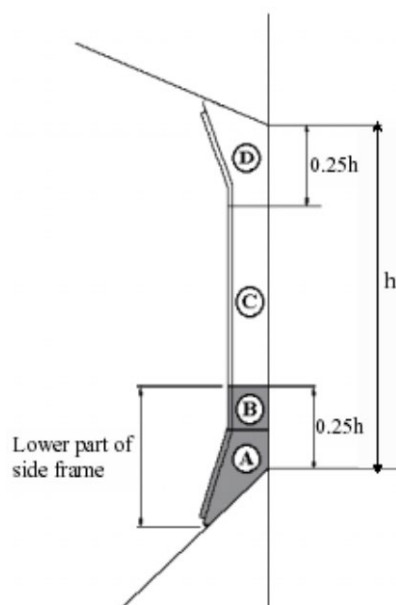

Fig. 1. Zones of side shell frames and brackets

4.3 Pitting and grooving

Pits can grow in a variety of shapes, some of which would need to be ground before assessment. Pitting corrosion may be found under coating blisters, which shall be removed before inspection.

To measure the remaining thickness of pits or grooving, the normal ultrasonic transducer (generally 10 mm diameter) will not suffice. A miniature transducer (3 to 5 mm in diameter) shall be used.

Alternatively the gauging firm shall use a pit gauge to measure the depth of the pits and grooving and calculate the remaining thickness.

4.4 Assessment based upon area

The assessment is based upon intensity determined from Fig. 2 below.

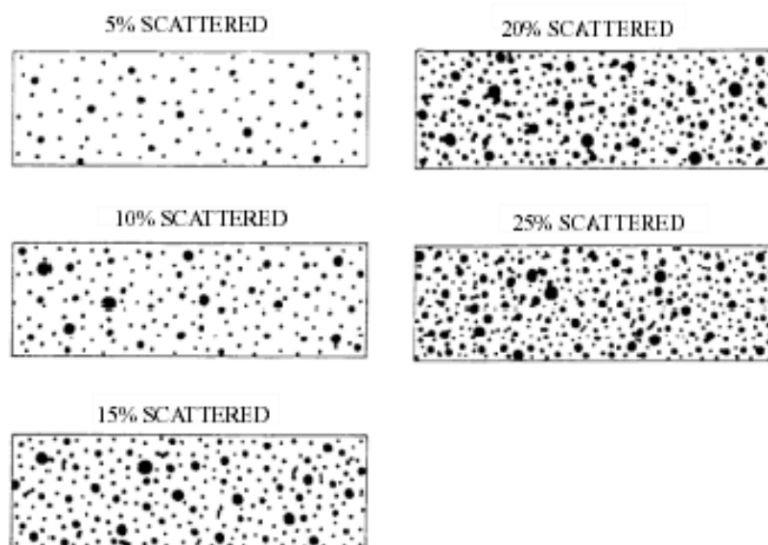

Fig. 2. Pitting intensity diagrams (from 5% to 25% intensity)

If pitting intensity is higher than 15% in an area (see Fig. 2), then thickness measurements shall be taken to check the extent of the pitting corrosion. The 15% is based upon pitting and grooving on only one side of the plate.

In cases where pitting is evident as defined above (exceeding 15%), then an area of 300 mm diameter or more (or, where this is impracticable on the frame flange or the side shell, hopper tank plating or topside tank plating attached to the side frame, an equivalent rectangular area), at the most pitted part, shall be cleaned to bare metal, and the thickness measured in way of the five deepest pits within the cleaned area. The least thickness measured in way of these pits shall be taken as the thickness to be recorded.

The minimum acceptable remaining thickness in any pit or groove is equal to:

- 75% of the as built thickness, for pitting or grooving in the cargo hold side frame webs and flanges,
- 70% of the as built thickness, for pitting or grooving in the side shell, hopper tank and topside tank plating attached to the cargo hold side frame, over a width up to 30 mm from each side of it.

4.5 Gauging methodology

The numbers of side frames to be measured are equivalent to those of Class Renewal Survey or Intermediate Survey corresponding to the ship's age. Representative thickness measurements shall be taken for each zone as specified below.

Special consideration to the extent of the thickness measurements may be given by PRS if the structural members show no thickness diminution with respect to the as built thickness and the coating is found in "as-new" condition (i.e. without breakdown or rusting).

Where gauging readings close to the criteria are found, the number of hold frames to be measured shall be increased.

If renewal or other measures according to *Publication 63/P* shall be applied on individual frames in a hold, then all frames in that hold shall be gauged.

There is a variety of construction methods used for side shell frames in bulk carriers. Some have faceplates (T sections) on the side shell frames, some have flanged plates and some have bulk plates. The use of faceplates and flanged sections is considered similar for gauging purposes in that both the web and faceplate or web and flange plate shall be gauged.

If bulb plate has been used, then web of the bulb plate shall be gauged in the normal manner and the sectional modulus has to be specially considered.

4.6 Gaugings for zones A, B & D

Web plating

The gauging pattern for zones A, B & D shall be a five-point pattern (see Fig. 3). The 5 point pattern shall be over the depth of the web and the same area vertically. The gauging report shall reflect the average reading.

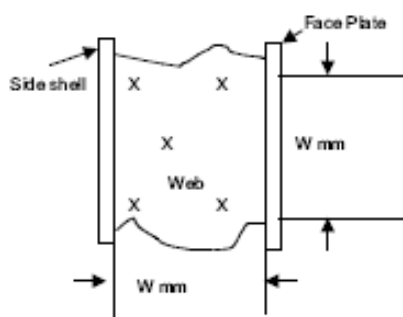

Fig. 3. Typical five-point pattern on the web plate

4.7 Gaugings for zone C

Web plating

Depending upon the condition of the web in way of zone C, the web shall be measured by taking 3 readings over the length of zone C and averaging them. The average reading shall be compared with the allowable thickness. If the web plating has general corrosion then this pattern shall be expanded to a five-point pattern as noted above.

4.8 Gaugings for section a) and b) (flanges and side shell plating)

Where the lower bracket length or depth does not meet the PRS requirements specified in the *Rules for Classification and Construction of Sea-going Ships, Part II – Hull*, gaugings shall be taken at sections a) and b) to calculate the actual section modulus required in sub-chapter 3.4 of *Publication 63/P* (see Fig. 4). At least 2 readings on the flange/faceplate shall be taken in way of each section. At least 1 reading of the attached shell plating shall be taken on each side of the frame (i.e. fore and aft) in way of section a) and section b).

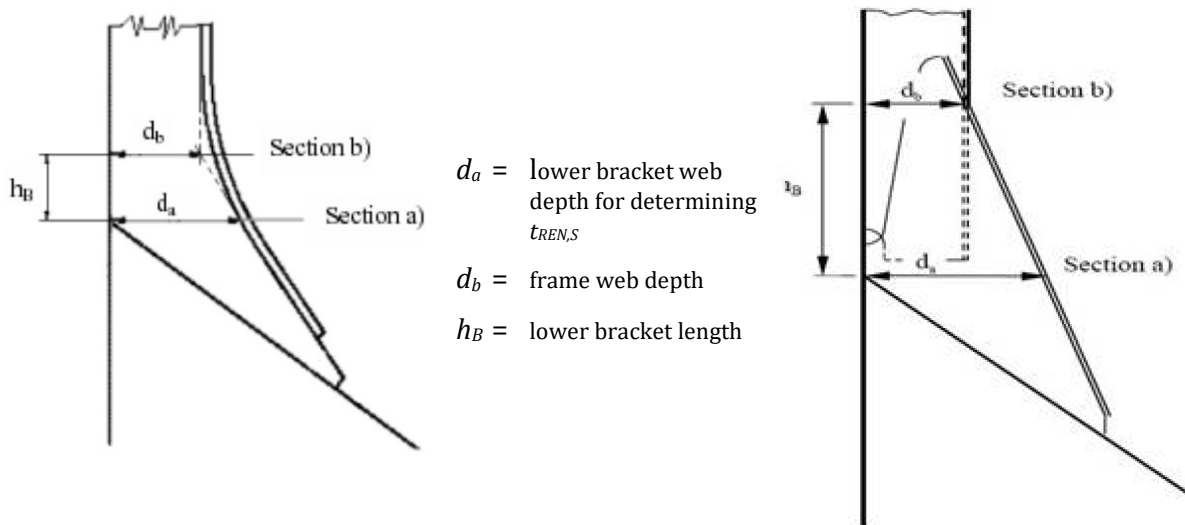

Fig. 4. Sections a) and b)

See Form TM7-BC S31 (page 81).

Annex VIA

HULL SURVEY PROGRAMME

- 1 *Hull Survey Programme* (Form 328PR) covers the minimum extent of overall surveys, close-up surveys, thickness measurements and pressure testing within the cargo length area, cargo holds, ballast tanks, including fore and afterpeak tanks, required by the present Publication.
- 2 *Hull Survey Programme* shall be worked out by the Owner in co-operation with PRS.

Annex VIB

SURVEY PLANNING QUESTIONNAIRE

Survey Planning Questionnaire (Form 628) is dedicated to collect necessary information to enable the Owner, with PRS cooperation, to develop *Hull Survey Programme* required by the present Publication. The Questionnaire, reflecting current information, shall be completed by the Owner. Completed Questionnaire shall be delivered to PRS.

List of amendments effective as of 1 July 2024

Item	Title/Subject	Source
1.2, 3.2.2.1 4.2.3	Requirements update	IACS UR Z10.2 rev.37