



RULES

PUBLICATION 11/P

ENVIRONMENTAL TESTS ON MARINE EQUIPMENT

July
2024

Publications P (Additional Rule Requirements) issued by Polski Rejestr Statków complete or extend the Rules and are mandatory where applicable.

GDAŃSK

Publication 11/P – Environmental Tests on Marine Equipment – July 2024 was approved by PRS Board on 20 June 2024 and enters into force on 1 July 2024.

This Publication replaces *Publication No. 11/P – Environmental Tests on Marine Equipment, July 2023*.

© Copyright by Polish Register of Shipping*, 2024

* *Polish Register of Shipping* means *Polski Rejestr Statków S.A.*, seated in Gdańsk, al. gen. Józefa Hallera 126, 80-416 Gdańsk, Poland, registered in the Register of Entrepreneurs of the National Court Register, under entry number 0000019880. Polish Register of Shipping, its affiliates and subsidiaries, their respective officers, employees or agents are, individually and collectively, referred to as Polish Register of Shipping or as PRS for short.

CONTENTS

	Page
1 General	5
1.1 Application	5
1.2 Tests – General	5
1.3 Definitions	6
2 Tests	6
2.1 Visual Inspection	6
2.2 Performance Tests	6
2.3 “Power Supply Failure” Test.....	6
2.4 “Power Supply Variations” Test.....	7
2.5 “Dry Heat” Test (Test B in accordance with Publication IEC 60068-2-2)	8
2.6 “Damp Heat-Cyclic” Test (Test Db in accordance with Publication IEC 60068-2-30).....	8
2.7 “Cold” Test” (Test A in accordance with Publication IEC 60068-2-1)9	
2.8 “Sinusoidal Vibrations” Test (Test Fc in accordance with Publication IEC 60068-2-6)	10
2.9 “Inclination” Test (in accordance with Publication IEC 60092-504)	11
2.10 “Enclosure Protection” Test	11
2.11 “Salt Mist” Test (Test Kb in accordance with Publication IEC 60068-2-52).....	11
2.12 Explosion and Intrinsic Safety Test	12
2.13 “Mould Growth” Test (Test J in accordance with Publication IEC 60068-2-10).....	12
2.14 “Electrostatic Discharge” Test (in accordance with Publication IEC 61000-4-2)	13
2.15 “ Electromagnetic field” Test (in accordance with Publication IEC 61000-4-3).....	13
2.16 “Fast Transient Interference (Burst)” Test (<i>in accordance with Publication IEC 61000-4-4</i>).....	13
2.17 “Conducted Radio Frequencies Interference” Test (in accordance with Publication IEC 61000-4-6 and Publication IEC 60945)	14
2.18 “Surge Voltage Immunity” Test (in accordance with Publication IEC 61000-4-5).....	14
2.19 “Conducted Audio Frequencies Interference” Test	15
2.20 “Radiated Emission” Test (in accordance with Publication CISPR 16-2-3)	16
2.21 “Conducted Emission” Test (in accordance with Publication CISPR 16-2-1)	17
2.22 Insulation Resistance Measurement	17
2.23 “High Voltage” Test	17
2.24 “Flame Retardance” Test	18
2.25 Flammability Test of Electro-insulating Materials.....	18
2.26 Tests of cable trays / protective casings made of plastics materials.....	21

1 GENERAL

1.1 Application

1.1.1 The present Publication specifies the scope and conditions of conducting type tests of – but not confined to – the electrical, electronic and programmable equipment which constitute, or are components of:

- control, monitoring and alarm systems, and
- protection systems

to be installed on board ships.

This *Publication* may also be applied to type tests of other equipment, which is subject to PRS survey, to verify its suitability to be used on board ships.

1.1.2 In the case of products intended for operation in conditions more severe than those specified in the *Rules* (see *Part VIII – Electrical Installations and Control Systems*, sub-chapter 2.1), the scope and parameters of the tests are subject to special consideration by PRS.

1.1.3 For the navigational and radio communication equipment, type tests shall be performed in accordance with the requirements specified in Publication IEC 60945. Tests for electromagnetic compatibility of electrical and electronic equipment (e.g. computer equipment) liable to cause electromagnetic disturbance to the navigational and radio communication equipment fitted on the navigating bridge shall be performed in accordance with the requirements specified in a respective Publication IEC.

1.1.4 Equipment intended to be installed on ships contracted for construction on or after 1 January 2022 is to comply with this Publication edition January 2020.

1.2 Tests – General

1.2.1 Prototype of the product shall be subjected to tests specified in Chapter 2. It is recommended that the sequence of the tests be as specified in Chapter 2. PRS may require that products manufactured in series shall also be subjected, within full or a limited scope, to the tests.

1.2.2 Unless expressly provided otherwise in the description of particular tests, the tests shall be performed in the following ambient conditions, hereinafter referred to as standard atmosphere conditions:

- temperature: $25\text{ °C} \pm 10\text{ °C}$
- relative humidity: $60\% \pm 30\%$,
- atmospheric pressure: $960\text{ hPa} \pm 100\text{ hPa}$.

When a specific product is required to fulfil the requirements of the respective Publication IEC (e.g. protective devices, relays), functional tests performed in accordance with the respective Publication IEC shall be a part of initial tests and subsequent performance tests after environmental testing (where required).

1.2.3 Unless expressly provided otherwise in the description of particular tests, standard power supply conditions shall be maintained during the tests, i.e.:

- rated voltage and rated frequency of electric energy,
- rated supply pressure of pneumatic and hydraulic systems.

1.2.4 The Publications IEC/CISPR specify testing procedures to be used. Analogous procedures, however, may be used and accepted by PRS subject to the fulfilment of the specified requirements (parameters, etc.). In any case, the latest versions of the above mentioned Publications apply.

1.2.5 Acceptance of the product prototype will be based on review of the manufacturer's certified test reports by PRS and design review of the product. Omission of certain tests may be considered, taking into consideration the location of installation, functionality, assembly parts, etc. of the equipment. In general, field sensors (e.g., pressure transmitters), field devices (e.g., solenoid valves), circuit breakers and cables may be exempted from the tests specified in Chapter 2 (TESTS) if design review shows that some tests are not applicable.

1.2.6 In some cases equivalent testing procedures may be accepted by PRS.

1.2.7 Later versions (including revisions) of the international standards specified in this Publication are acceptable for use provided that PRS determines them to be equivalent to the technical specifications of this Publication.

1.2.8 Unified Requirements stated in the other columns are fulfilled.

1.3 Definitions

Vibration effects – changes of properties, as well as mechanical resonance occurring in the product due to vibrations.

Preconditioning – exposing the product to specific environmental factors in order to obtain its characteristics as required for preliminary measurements and checks.

Standard atmosphere conditions – the values of temperature, relative humidity and atmospheric pressure specified in paragraph 1.2.2.

Recovery – exposing the product to specific environmental factors in order to stabilise its characteristics before the final measurements and checks.

2 TESTS

2.1 Visual Inspection

During visual inspection it shall be verified, as far as it is practicable without the use of tools and the product dismantling, that the product fulfils the requirements and data specified in the approved technical documentation.

2.2 Performance Tests

The purpose of the tests is to ascertain that the product operation is in compliance with the specified requirements and that the product under test has not suffered any deterioration caused by the individual environmental tests.

With respect to computer systems, the purpose of the tests is to check their self-monitoring features and protection against unauthorized access to the computer memory and erroneous use of control elements.

2.3 “Power Supply Failure” Test

Power supply shall be interrupted three times within a 5-minute period. The switching off time shall be 30 seconds in each case.

The time of 5 minutes may be exceeded if the equipment under test needs a longer time for start up, e.g. booting sequence for computer equipment. For equipment which requires booting, one additional power supply interruption during booting shall be performed.

The product shall operate properly after the test.

It shall be verified that possible corruption of program or data held in programmable electronic systems has not occurred.

2.4 “Power Supply Variations” Test

2.4.1 Electric Power

The product shall be supplied with electric power in accordance with combinations specified in Table 2.4.1 or 2.4.2 as well as measurements and verifications provided by the test programme, shall be performed.

Table 2.4.1

Combination No.	Deviation from rated value, [%]	
	Voltage	Frequency
	Permanent deviation (at least 15 min.)	
1	+6	+5
2	+6	-5
3	-10	-5
4	-10	+5
	Transient deviation	
	1.5 s	5 s
	5	+20
6	-20	-10

Table 2.4.2

D.C. power supply	
Voltage variations	Deviation from rated value, [%]
continuous voltage variation	± 10
cyclic voltage variation	5 ¹⁾
voltage ripple	10 ²⁾

¹⁾ variation frequency – 250 to 350 Hz

²⁾ ripple duration – 0.5 s

The battery supplied product shall be additionally fed, for at least 15 minutes, with electric power of the voltage:

- 25% lower and 30% higher than the rated value – for the product connected to the battery during charging;
- 25% lower and 20% higher than the rated value – for the product not connected to the battery during charging.

On completion of the test, the product shall be checked for failure and for operational capability.

2.4.2 Hydraulic and Pneumatic Energy

Product shall be supplied, for 15 minutes, with hydraulic or pneumatic energy of the pressure varying within ± 20%.

On completion of the test, the product shall be checked for failure and for operational capability.

2.5 “Dry Heat” Test (test B in accordance with Publication IEC 60068-2-2)

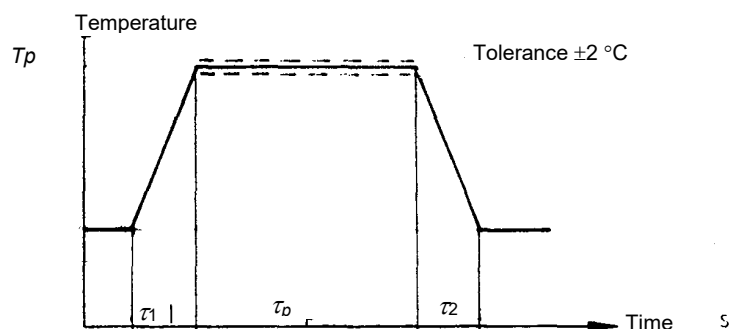

Procedure	Test parameters	Other information
Test Bb for non-heat dissipating Equipment acc. IEC 60068-2-2	Temperature: $55^{\circ} \pm 2^{\circ}\text{C}$ Duration: 16 hours or Temperature: $70^{\circ}\text{C} \pm 2^{\circ}\text{C}$ Duration: 16 hours	<ul style="list-style-type: none"> - equipment operating during conditioning and testing; - functional test (b) during the last hour at the test temperature. - for equipment specified for increased temperature the dry heat test is to be conducted at the agreed test temperature and duration.
Test Be for heat dissipating Equipment acc. IEC 60068-2-2	Temperature: $55^{\circ} \pm 2^{\circ}\text{C}$ Duration: 16 hours or Temperature: $70^{\circ}\text{C} \pm 2^{\circ}\text{C}$ Duration: 16 hours	<ul style="list-style-type: none"> - equipment operating during conditioning and testing with cooling system on if provided; - functional test (b) during the last hour at the test temperature. - for equipment specified for increased temperature the dry heat test is to be conducted at the agreed test temperature and duration.

Note: Dry heat at 70°C is to be carried out to automation, control and instrumentation equipment subject to high degree of heat, for example mounted in consoles, housings, etc. together with other heat dissipating power equipment.

2.6 “Damp Heat-Cyclic” Test (Test Db in accordance with Publication IEC 60068-2-30)

Before the test, insulation resistance shall be measured – see sub-chapter 2.22. The switched on product shall then be placed in a chamber at a temperature of $25 \pm 3^{\circ}\text{C}$.

After the temperature of the product has stabilized, the relative humidity of the chamber shall be increased up to 95-100%, within not more than 1h, and the 24 h testing cycle shall commence.

While the relative humidity is being maintained at 95-100%, the temperature shall be raised up to $55 \pm 2^{\circ}\text{C}$ within 3 hours. Over the following 9 h, the temperature shall be maintained at $55 \pm 2^{\circ}\text{C}$ and the relative humidity at 90-96%. Then, within 3-6 hours, the temperature shall be lowered to reach $25 \pm 3^{\circ}\text{C}$ and maintained at this level to complete the 24 h cycle. During the temperature decrease stage until the end of the cycle the relative humidity shall be maintained at 95-100%.

Two test cycles shall be performed. The product shall be switched on during the first testing cycle. During the second testing cycle, the product shall be switched off, except for performance tests.

Performance tests shall be performed during the first two hours of the first testing cycle at a temperature of $55 \pm 2^{\circ}\text{C}$, as well as during the last two hours of the second testing cycle at a temperature of $55 \pm 2^{\circ}\text{C}$. The second testing cycle duration may be extended to enable proper conducting of the performance tests.

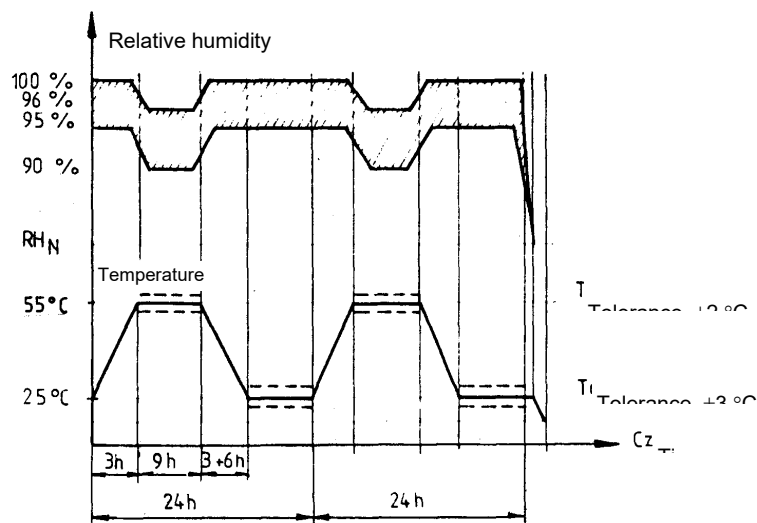

After the standard temperature has been reached, the product shall be subjected to recovery, performance tests and insulation resistance measurements.

2.7 "Cold" Test" (Test A in accordance with Publication IEC 60068-2-1)

Before the test, insulation resistance shall be measured – see sub-chapter 2.22. The switched off product shall then be placed in a chamber at a standard temperature and, within τ_1 time interval, the temperature shall be lowered to T_p value. After the product temperature has reached stability, the value of T_p shall be maintained for time interval τ_p . Then, the temperature shall be raised up to the standard value within τ_2 time interval. The test parameters are specified in Table 2.7.

Time intervals τ_1 and τ_2 shall be so selected that the rate of temperature change in the chamber, averaged for any 5 min period, will not exceed 1 °C/min.

During the last hour of product exposure to cold, performance tests shall be performed.

After the temperature has reached the standard value, the product shall be subjected to recovery, performance tests and insulation resistance measurements.

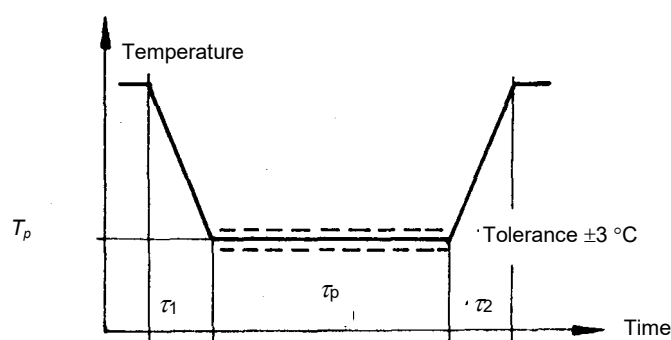

Table 2.7

Item	Product location	T_p [°C]	τ_p [h]
1	All places, except those specified in item 2	+5 ± 3	2
2	Non-weather protected locations or cold locations	-25 ± 3	2

2.8 “Sinusoidal Vibrations” Test (Test Fc in accordance with Publication IEC 60068-2-6)

2.8.1 General

Testing cycle consists of preliminary measurement of vibration effects frequencies and vibration resistance test.

The product shall be tested in successive complete testing cycles in three mutually perpendicular planes.

Test parameters are as follows:

- vibration frequency range: 2.0_{-0}^{+3} Hz to 13.2 Hz – displacement amplitude ± 1.00 ;
- vibration frequency range: 13.2 Hz to 100 Hz – acceleration amplitude $\pm 0.7 g$.

For products intended to be installed on machinery where severe vibration conditions prevail, e.g. internal combustion engines and compressors, the test parameters are as follows:

- vibration frequency range: 2.0 Hz to 25.0 Hz – displacement amplitude ± 1.6 mm;
- vibration frequency range: 25.0 Hz to 100 Hz – acceleration amplitude $\pm 4.0 g$.

For products intended to be installed in more severe conditions, e.g. exhaust pipes or fuel injection systems of i.c. engines with self-ignition – of medium speed ($250 \text{ r.p.m} < n \leq 1500 \text{ r.p.m}$) and high speed ($n > 1500 \text{ r.p.m}$), the test parameters shall be agreed with PRS in each particular case. In that case, the required values may be as follows: frequency range from 40 Hz to 2000 Hz – acceleration amplitude $\pm 10,0 g$, temperature 600°C , duration 90 minutes.

It is recommended that the acceptable amplitudes of vibration effects measured on the product should not exceed five times the displacement (acceleration) amplitude, adopted for the given frequency.

2.8.2 Preliminary Check of Vibration Effects’ Frequency

Product shall be fixed on the vibration table, switched on and subjected to vibrations of the frequencies ranging from the minimum to maximum and vice versa. Vibration effects’ frequencies shall be measured with an accuracy of 0.5 Hz.

Sweep over a restricted frequency range between 0.8 to 1.2 the critical frequencies specified in sub-chapter 2.8.1 may be used where appropriate. Critical frequency is the frequency at which the equipment being tested may exhibit malfunction and/or performance deterioration or mechanical resonances and/or other adverse response effects, e.g. chatter.

2.8.3 Vibration Resistance Test for Products for which no Vibration Effects Were Observed

Product shall be subjected to vibrations for 90 minutes, with the vibration frequency of 30 Hz in every plane. During this test, performance tests as well as the measurements and verification provided by the test programme shall be performed. The product shall neither change its operational state nor fail.

2.8.4 Vibration Resistance Test for Products of Distinct Vibration Effects, and for which Vibration Effect Amplitudes Measured Are Equal to or Surpass the Doubled Displacement (Acceleration) Amplitude Adopted for Specific Frequency

Product shall be subjected to successive vibrations at frequencies of vibration effects. The test duration, for each frequency, is 90 minutes.

Where several resonance frequencies are detected close to each other, the product shall be subjected to vibrations during 120 minutes.

Performance tests, measurements and verification, specified in the test programme, shall be performed during the test. The product shall neither show excessive resonances nor fail. The test shall not affect the product operation.

2.9 “Inclination” Test (in accordance with Publication IEC 60092-504)

2.9.1 Static Inclination 22.5°

The switched on product shall be inclined from the vertical to an angle of at least 22.5° and then to at least 22.5° on the opposite side in the same plane.

Next the product shall be inclined from the vertical to an angle of at least 22.5° perpendicularly to the previous plane, then inclined to at least 22.5° on the opposite side in the same plane.

The test duration in each position shall be sufficient to fully evaluate the product operation.

2.9.2 Dynamic Inclination 22.5°

The switched on product shall be rolled to an angle of 22.5° on each side of the vertical in both planes, as specified in sub-chapter 2.9.1. The rolling time shall be 10 seconds. The test duration in each plane shall be at least 15 minutes.

During the test and on its completion, the product shall operate properly.

Note: Both static and dynamic inclination tests are not required for equipment with no moving parts.

2.10 “Enclosure Protection” Test

The test on penetration of water and alien elements into the enclosure of products, having the specified protection level, shall be performed in accordance with standards agreed with PRS, e.g. IEC 60529 or other acceptance conditions approved by PRS.

2.11 “Salt Mist” Test (Test Kb in accordance with Publication IEC 60068-2-52)

The test is intended for products exposed to sea weather conditions.

PRS may allow the test to be performed on the selected, representative parts of the product.

Before the test, insulation resistance of the product shall be measured in accordance with the requirements specified in sub-chapter 2.22 and performance tests shall be performed. Next, the switched off product shall be placed in a chamber and exposed to salt mist.

The product shall be exposed to sprayed salt solution 4 times for a period of 2 h each, within the temperature range of 25°C ±10°C. After each spraying, the product shall be kept for 7 days in a humidity chamber at a temperature of 40 ±2°C and relative humidity of 93⁺²₋₃%.

Solution, prepared by dissolving 5 ±1 parts by weight of chemically pure sodium chloride in 95 parts by weight of distilled or demineralised water, shall be used as the spraying agent. Hydrogen ion exponent (pH) of the solution shall range between 6.5 and 7.2 at a temperature of 20 ±2°C. For pH control, diluted muriatic acid or sodium chloride shall be used.

Salt mist density shall be such that each 80 cm² of horizontal surface will be reached by at least 2 ml of the solution during 1 hour. Condensed mist shall not be reused.

The air used to produce the salt mist shall be free from oil and other contaminations, and shall be heated to allow the solution to reach the required temperature.

Performance test shall be performed on the 7th day of each storage period in a humid environment.

After the test, the product shall be rinsed for 5 minutes in running water, then rinsed in distilled water, water drops being shaken off. Then, the product shall undergo recovery for a period from 1 hour to not more than 2 hours and shall be subjected to visual examination. The surface of metal parts shall not show significant corrosion. However, some traces of corrosion on sharp edges may be permitted.

Finally, after the lapse of 4-6 hours from the moment of removing the product from the chamber, insulation resistance measurement and performance tests shall be performed.

2.12 Explosion and Intrinsic Safety Test

Explosion and intrinsic safety tests of the equipment shall be performed in accordance with valid standards. The tests shall be performed in specialised and approved laboratories.

2.13 “Mould Growth” Test (Test J in accordance with Publication IEC 60068-2-10)

The test shall be performed on the switched off product. Subject to PRS agreement, instead of the assembled product, the product representative parts or samples of the relevant materials may be tested.

The product and 3 reference strips shall be sprayed with aqueous suspension of mould spores specified in Table 2.13 and placed in a dark and tight container or chamber. Inside the container or chamber, the temperature of $29\text{ °C} \pm 1\text{ °C}$ and the relative humidity of more than 90% shall be developed and maintained for 28 days. The temperature in the chamber or container shall not vary by more than 1 °C .

After 7 days of treatment, the chamber or container shall be opened, the growth of mould checked on reference strips and then the chamber tightly closed again. Where no growth of mould on any of the strips is observed, the test shall be conducted again by using a fresh suspension of mould spores.

On the 14th and 21st day of the test, the chamber or container shall be opened for 5 seconds or 5 minutes, depending on their volume.

The reference strips shall be made of clean white filter paper placed on Petri dishes, sterilised and soaked by means of modified solution of Czapek-Dox nutrient salt with saccharose.

On completion of the test, the product and the reference strips, immediately after being taken out of the chamber or container, shall be subjected to visual examination with the naked eye and 50-fold magnification. The product is considered as resistant to mould growth when no focus of mould can be seen in 50-fold magnification or only some single germinated spores are observed.

Table 2.13

Item	Name of spore
1	<i>Aspergillus niger</i> (v. Tieghem)
2	<i>Aspergillus terreus</i> (Thom)
3	<i>Aureobasidium pullulans</i> [/De Barry/Arnaud]
4	<i>Paecilomyces varioti</i> (Bainier)
5	<i>Penicillium funicolosum</i> (Thom)
6	<i>Penicillium ochrochloron</i> (Biourge)
7	<i>Scopulariopsis brevicaulis</i> [/Sacc./Bain Var. <i>Glabra</i> Thom.]
8	<i>Trichoderma viride</i> (Pers. ex Fries.)

2.14 “Electrostatic Discharge” Test (in accordance with Publication IEC 61000-4-2)

The purpose of the test is to check the product resistance to electrostatic discharge which may occur when the product is touched by personnel.

Test parameters:

- contact discharge 6 kV
- air discharge 2 kV, 4 kV, 8 kV
- voltage polarisation +, –
- discharge electrode in accordance with IEC 61000-4-2
- test level 3.

First, the product resistance shall be checked while generating discharges to the earth clamp. The discharge shall be generated by means of discharge electrode which shall be moved towards and perpendicularly to discharge plane, until the spark-over is reached and then the electrode shall be withdrawn.

At least 10 discharges of each voltage polarisation shall be generated in different places on the product that can normally be reached by personnel, the interval between single discharges being 1 s.

After the test, the product shall continue to operate as intended. No degradation of performance or loss of function is allowed, as defined in the manufacturer’s technical specification. During the test, degradation or loss of function or performance which is self-recoverable is, however, allowed, but no change of actual operating state or stored data is allowed.

2.15 “Electromagnetic field” Test (in accordance with Publication IEC 61000-4-3)

- Frequency range: 80 MHz to 6 GHz
Modulation**: 80% AM at 1000Hz
Field strength: 10V/m
Frequency sweep rate: $\leq 1.5 \times 10^{-3}$ decades/s (or 1%/3 sec)
According to test level 3.

** *If for tests of equipment an input signal with a modulation frequency of 1000 Hz is necessary a modulation frequency of 400 Hz may be chosen.*

Purpose of test and additional information:

- to simulate electromagnetic fields radiated by different transmitters;
- the test is to be confined to the appliances exposed to direct radiation by transmitters at their place of installation;
- Performance Criterion A (For continuous phenomena): The Equipment Under Test shall continue to operate as intended during and after the test. No degradation of performance or loss of function is allowed as defined in relevant equipment standard and the technical specification published by the manufacturer.

If an equipment is intended to receive radio signals for the purpose of radio communication (e.g. wifi router, remote radio controller), then the immunity limits at its communication frequency do not apply, **subject to the provisions “Specific requirements for wireless data links” in PRS Publication 9/P.**

2.16 “Fast Transient Interference (Burst)” Test (in accordance with Publication IEC 61000-4-4)

The purpose of the test is to check the product resistance to short duration pulses generated by switching contacts or short circuits in the electric equipment and conducted to the product.

Interfering signal:

- test voltage 2 kV, power supply lines and earthing 1 kV, signal and control lines
- polarisation +/-
- pulse rise time (from 10% to 90% value) 5 ns
- pulse duration (50% value) 50 ns
- pulse frequency within the cycle 5 kHz (1 kV) for signal and control lines, 2.5 kHz (2 kV) for power supply lines and earthing
- cycle duration 15 ms
- repetition time 300 ms
- test duration for each polarity 5 min
- test level 3.

Interfering signal, generated by test generator, shall be connected to power supply lines and earthing by coupling/decoupling network, and to signal and control lines – through capacitive coupling clamp.

After the test, the product shall continue to operate as intended. No degradation of performance or loss of function is allowed, as defined in the manufacturer's specification. During the test, degradation or loss of function or performance which is self-recoverable is, however, allowed, but no change of actual operating state or stored data is allowed.

2.17 "Conducted Radio Frequencies Interference" Test (in accordance with Publication IEC 61000-4-6 and Publication IEC 60945)

The purpose of the test is to check the product resistance to interference in power supply and in signal and control lines, generated by electromagnetic fields of high frequency.

Interfering signal:

- frequency range 150 kHz to 80 MHz
- effective value 3 V rms
- modulation 80%
- modulation frequency 1000 Hz
- test level 2.

Additionally, for the equipment installed in the bridge and deck zone, the interfering signal amplitude shall be 10 V rms at selected frequencies: 2 MHz, 3 MHz, 4 MHz, 6.2 MHz, 8,2 MHz, 12.6 MHz, 16.5 MHz, 18.8 MHz, 22 MHz and 25 MHz.

Interfering signal, generated by test generator, shall be connected successively to the tested lines by coupling/decoupling network or shall be injected by injection current clamps or EM clamps. Provision shall be made for recording voltage and current intensity during the test. The rate of interference frequency shall not be higher than 1.5×10^{-3} decades/s or 1%/3 s. If the appliance utilises an input signal with a modulation frequency of 1000 Hz, a modulation frequency of 400 Hz shall be chosen for the test.

During and after the test, the product shall continue to operate as intended. No degradation of performance or loss of function is allowed, as defined in the manufacturer's specification.

2.18 "Surge Voltage Immunity" Test (in accordance with Publication IEC 61000-4-5)

The purpose of the test is to check the product resistance to short-duration interference generated by switching contacts and short circuits and conducted to the product.

Interfering signal (open circuit voltage):

- amplitude 1 kV line/earth; 0.5 kV line/line
- polarisation +/-
- pulse rise time (between 10% and 90% value) 1.2 μ s
- pulse width (50% value) 50 μ s
- repetition rate ≥ 1 pulse/min
- No. of pulses per polarity 5
- application continuous
- test level 2

Interfering signal (short circuit current):

- puls rise time 8 μ s
- puls width 20 μ s.

Interfering signal, generated by combination wave generator, shall be connected to power supply lines and earthing through capacitive coupling.

The test is applicable to AC and DC power ports.

After the test, the product shall continue to operate as intended. No degradation of performance or loss of function is allowed, as defined in the manufacturer's specification. During the test, degradation of performance or loss of function which is self-recoverable is allowed, but no change of actual operating state or stored data is allowed.

2.19 "Conducted Audio Frequencies Interference" Test

The purpose of the test is to check the product resistance to voltage deviations generated by electronic consumers, especially high power consumers.

Diagram of a typical system for AC or DC power supply is shown in Fig. 2.19.

Interfering signal for AC:

- frequency range rated frequency to 200th harmonic
- test voltage (rms) 10% of supply to 15th harmonic reducing to 1% at 100th harmonic and maintain this level to the 200th harmonic, min 3 V.

Interfering signal for DC:

- frequency range 50 Hz to 10 kHz
- test voltage (rms) 10% of supply, min. 3 V.

If the impedance is too low to maintain the test voltage during the above mentioned test, the power used in the supply lines shall be restricted to 2 W. For keeping max 2 W, the test signal voltage of may be lower.

Interfering signals shall be connected to power supply lines through a coupling transformer. Both voltage and current intensity shall be recorded during the test.

During and after the test, the product shall continue to operate as intended. No degradation of performance or loss of function is allowed, as defined in the manufacturer's specification. Neither product malfunction nor its damage shall be caused by the test.

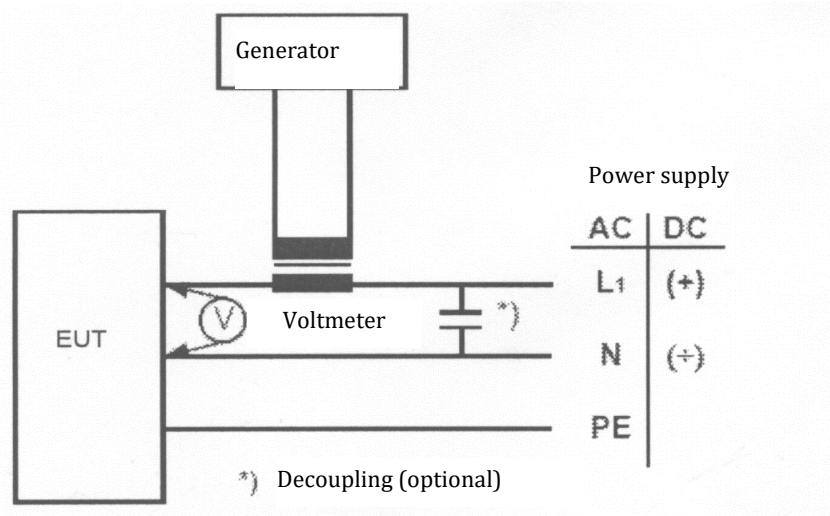

Fig. 2.19. Test set-up – conducted low frequency test

2.20 “Radiated Emission” Test (in accordance with Publication CISPR 16-2-3)

Procedure	Test parameters	Other information
CISPR 16-2-3 IEC 60945 for 156-165 MHz	<p>--- Limits below 1000 MHz ---</p> <p>For equipment installed in the bridge and deck zone.</p> <p>Frequency range: Quasi peak limits:</p> <p>0.15 - 0.3 MHz 80 - 52 dBμV/m</p> <p>0.3 - 30 MHz 52 - 34 dBμV/m</p> <p>30 - 1000 MHz 54 dBμV/m</p> <p>except for:</p> <p>156 -165 MHz 24 dBμV/m</p> <p>For equipment installed in the general power distribution zone.</p> <p>Frequency range: Quasi peak limits:</p> <p>0.15 - 30 MHz 80 - 50 dBμV/m</p> <p>30 - 100 MHz 60 - 54 dBμV/m</p> <p>100 -1000MHz 54 dBμV/m</p> <p>except for:</p> <p>156 -165 MHz 24 dBμV/m</p> <p>--- Limits above 1000 MHz ---</p> <p>Frequency range: Average limit:</p> <p>1000 - 6000 MHz 54 dBμV/m</p>	<ul style="list-style-type: none"> - procedure in accordance with the standard but distance 3 m between equipment and antenna - for the frequency band 156 MHz to 165 MHz the measurement shall be repeated with a receiver bandwidth of 9 kHz (as per IEC 60945). - alternatively the radiation limit at a distance of 3 m from the enclosure port over the frequency 156 MHz to 165 MHz shall be 30 dB micro-V/m Peak (as per IEC 60945). <p>procedure in accordance with the standard (distance 3 m between equipment and antenna)</p> <ul style="list-style-type: none"> - equipment intended to transmit radio signals for the purpose of radio communication (e.g. wifi router, remote radio controller) may be exempted from limit, within its communication frequency range, subject to the provisions “Specific requirements for wireless data links” in PRS Publication 9/P.

2.21 “Conducted Emission” Test (in accordance with Publication CISPR 16-2-1)

The purpose of the test is to check if the level of conducted emission radiated by the product, measured at terminals, is maintained within the permissible limits. The test is applicable to AC and DC power ports.

Emission shall be measured by means of the quasi-peak measuring receivers.

Permissible emission levels:

- for products installed in the bridge and deck zone:

<i>Frequency range</i>	<i>Permissible level</i>
10-150 kHz	96-50 dB μ V
150-350 kHz	60-50 dB μ V
350 kHz-30 MHz	50 dB μ V

- for products installed in the general power distribution zone:

<i>Frequency range</i>	<i>Permissible level</i>
10-150 kHz	120-69 dB μ V
0.15-0.5 MHz	79 dB μ V
0.5-30 MHz	73 dB μ V.

2.22 Insulation Resistance Measurement

Insulation resistance shall be measured at the following tests:

- “damp heat-cyclic”,
- “cold”,
- “salt mist”,
- “high voltage”.

Insulation resistance measurement shall precede and succeed the test. The insulation resistance shall not be lower than the values specified in Table 2.22.

Table 2.22

Rated voltage [V]	Test voltage (DC) [V]	Minimum insulation resistance	
		Before test [M Ω]	After test [M Ω]
$U_n \leq 65$	$2 \times U_n$, min. 24	10	1
$U_n > 65$	500	100	10

Measurement for the products designed for a voltage exceeding 1000 V shall be made in accordance with the relevant requirements specified in *Part VIII – Electrical Installations and Control Systems* concerning equipment for a voltage exceeding 1000 V.

The insulation resistance shall be measured subsequently between each phase (pole) and the earth and, where appropriate, between the phases (poles).

Note: Certain components, e.g. for EMC protection may be required to be disconnected for this test.

2.23 “High Voltage” Test

Dielectric strength of the product insulation shall be checked by means of test voltage of rms value applied for 1 minute, as specified in Table 2.23.

Table 2.23

Rated voltage U_n [V]	Test voltage (AC voltage 50 or 60 Hz), [V]
to 65	$2 \times U_n + 500$
66 to 250	1500
251 to 500	2000
501 to 690	2500

The test for the products designed for a voltage exceeding 1000 V shall be performed in accordance with the relevant requirements specified in *Part VIII – Electrical Installations and Control Systems* concerning equipment for a voltage exceeding 1000 V.

Separate circuits shall be tested against each other and all circuits connected with each other shall be tested against earth (where practicable).

Printed circuits with electronic components may be removed during the test.

2.24 “Flame Retardance” Test

Flame retardance test shall be performed in accordance with Publication IEC 60092-101 or IEC 60695-11-5. The product or its casing shall be subjected to needle flame test 5 times, for a period of 15 seconds each time (the interval between the tests – 15 seconds) or once – for a period of 30 seconds.

After the needle flame has been removed, the length of burn-out or damaged part of the specimen shall not exceed 60 mm and in the event of flame or incandescence being present, it shall extinguish itself within 30 s of the removal of the needle flame without full combustion of the test specimen.

Any dripping material shall extinguish itself in such a way as not to ignite a wrapping tissue. The drip height shall be 200 mm \pm 5 mm.

2.25 Flammability Test of Electro-insulating Materials

2.25.1 Test Purpose

The purpose of the test is to assess flammability of solid insulating materials used as supporting members of live parts, as well as those acting as insulating covering for electrical and electronic equipment.

The above mentioned method cannot be applied for testing of cable and conductor insulation and sheaths.

2.25.2 Specimens

Specimen dimensions:
length – 200 mm,
width – 35 mm,
thickness – 3 ± 1.5 mm.

The possibility of testing specimens having different dimensions, as well as another testing method are subject to PRS consent in each particular case.

For testing materials of more than 4.5 mm in thickness, specimens shall be one-side machined so as to obtain the dimensions specified above. In that case, the test shall be performed on the unmachined side of the specimen.

Prior to testing, specimens shall be preconditioned at a temperature of $20 \pm 2^\circ\text{C}$ and a relative humidity of $65 \pm 3\%$.

2.25.3 Testing Device

Testing device shall consist of a filament loop, movable grip for specimen with a scale indicating the flame height, as well as a portable weight to adjust the filament thrust.

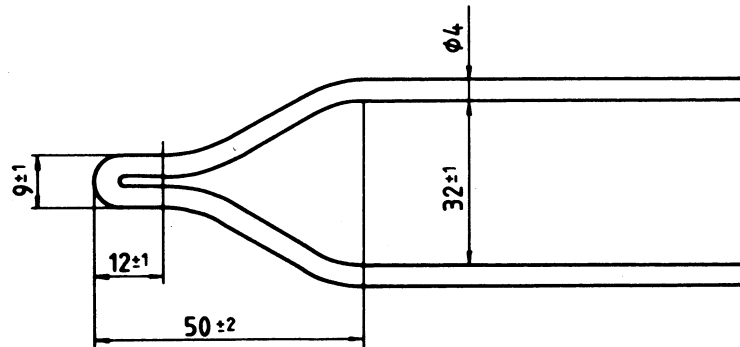

Fig. 2.25.3-1. Filament loop (dimensions in mm).

The filament loop shall be made of nichrome wire or of a ferrous chrome-aluminium alloy.

The shape and dimensions of filament loop shall be as shown in Fig. 2.25.3-1.

Movable grip for specimen shall be so placed that the specimen is pressed to the filament at right angle (see Fig. 2.25.3-2 and Fig. 2.25.3-3).

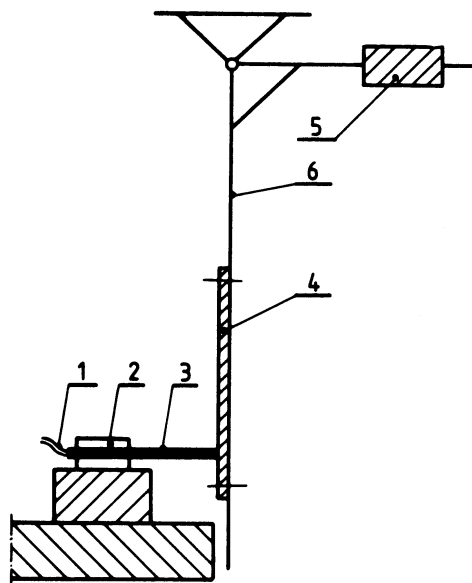

Fig. 2.25.3-2. Testing device principal diagram

1 – feeder; 2 – grip with clamps; 3 – filament loop; 4 – specimen; 5 – weight; 6 – frame with specimen grip.

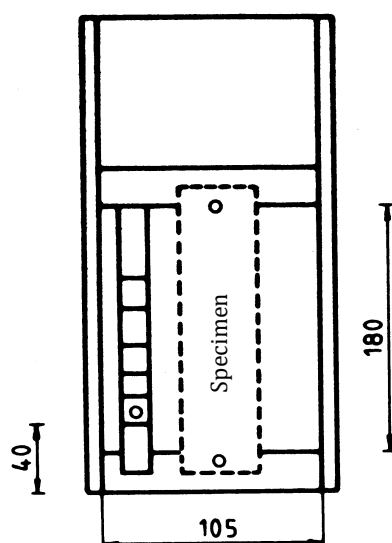

Fig. 2.25.3-3. Grip for specimen with scale (dimensions in mm).

2.25.4 Test

Filament loop shall be heated by electric current up to the temperature specified in Table 2.25.5. The loop temperature shall be constant at a continuous power supply during at least 120 seconds prior to the test commencement.

The grip with the specimen shall be pressed to the filament loop with a force of 1 N over the period specified in Table 2.25.5

If the insulating material catches fire during that time, the flame height shall be indicated on the scale and the specimen burning duration shall be determined, recording the time from the moment of the specimen removal from the filament to the moment of the flame going out.

2.25.5 Test Parameters

Parameters for testing flammability of insulating materials are specified in Table 2.25.5.

Table 2.25.5

Item	Test parameters	Test group	
		test group 1	test group 2
1	Temperature, [°C]	650	960
2	Duration of filament operation, [s]	60	30
3	Pressing force, [N]	1	1

2.25.6 Test Results

2.25.6.1 Insulating materials which do not ignite under exposures corresponding to the test group 1 or ignite, but the burning duration time is not longer than 30 seconds, irrespective of the flame height, are considered as fire-retardant and may be used as insulating coverings. However, they cannot be used for grips of current-carrying parts.

2.25.6.2 Insulating materials which do not ignite under exposures corresponding to the test group 2 or ignite, but the flame height does not exceed 3 cm, and the burning duration is not longer than 60 seconds, are considered as fire-retardant and may be used as insulating coverings, as well as for grips of current-carrying parts.

2.25.6.3 Tests shall be performed on three specimens.

If one of the specimens does not fulfil the requirements specified in paragraph 2.25.6.1 or 2.25.6.2, then the another set of three specimens shall be tested.

If more than one specimen is found not to fulfil the requirements specified in paragraphs 2.25.6.1 and 2.25.6.2, then such an insulating material shall not be considered as fire-retardant.

Insulating material is considered as fire-retardant only when, after the second test, all specimens may be considered as fire-retardant in accordance with the criteria specified in paragraphs 2.25.6.1 and 2.25.6.2.

2.26 Tests of cable trays / protective casings made of plastics materials.

2.26.1 Mechanical Requirements

2.26.1.1 Impact Resistance Test

The test should be performed according to IEC 60068-2-75:2014 using the pendulum hammer.

- .1 The test should be carried out on samples of cable tray lengths or cable ladder lengths, of 250 mm ± 5 mm long. Samples of ladder should consist of two side members with one rung positioned centrally. Samples of mesh trays should be prepared in such a way that there will be a wire in the centre.
- .2 Before the test, plastics components should be aged at a temperature of 90°C ± 2°C for 240 h continuously.
- .3 The samples should be mounted on wooden fibreboard of thickness 20 mm ± 2 mm.
- .4 The samples to be tested should be placed in a refrigerator, the temperature within which is maintained at the declared temperature according to 1.1 above with a tolerance of ± 2°C.
- .5 After 2 h, the samples should, in turn, be removed from the refrigerator and immediately placed in the test apparatus.
- .6 At 10 s ± 1 s after removal of each sample from the refrigerator the hammer should be allowed to fall with impact energy, the mass of the hammer and the fall height :

Approximate energy J	Mass of hammer kg	Fall height mm
10	5.0	200 ± 2

- .7 The impact should be applied to the base, or the rung, in the first sample, to one of the side members in the second sample, and to the other side member in the third sample. In each case, the impact should be applied to the centre of the face being tested.
- .8 After the test, the samples should show no signs of disintegration and/or deformation that will impair the safety.

2.26.1.2 Safe Working Load (SWL) Test

- .1 Cable trays/protective casings and joints should be assigned a Safe Working Load (SWL) satisfying the following criteria (tested at the temperatures -25°C to 90°C for outdoor use or +5°C to 90°C for indoor use):
 - the maximum deflection should not exceed L/100 where L is the distance between the supports,
 - no mechanical defects or failure are observed when tested to 1.7 x SWL.
- .2 All loads should be uniformly distributed (UDL) over the length and width of the samples as shown in Appendix 1. The loads should be applied in such a way that a UDL is ensured even in the case of extreme deformation of the samples. To allow for settlement of the samples, a pre-load of 10% of the test load unless otherwise specified, should be applied and held for at least 5 min, after which the measurement apparatus should be calibrated to zero.

- .3 The load should then be gradually increased evenly longitudinally and transversely up to the test load continuously or when a continuous increase is impractical, the load may be increased by increments.
These increments should not exceed about a quarter of the safe working load. The load increments should be distributed through the load plates longitudinally and transversely as evenly as is practical.
- .4 After loading, the deflection should be measured at the points specified to give a practical mid-span deflection.
- .5 The samples should be left and the deflections measured every 5 minutes until the difference between two consecutive sets of readings is less than 2 % with regard to the first set of the two consecutive sets of readings. The first set of readings measured at this point is the set of deflections measured at the test load.
- .6 When subject to the test load the samples, their joints and internal fixing devices, should show no damage or crack visible to normal view or corrected vision without magnification.
- .7 The load should then be increased to 1.7 times the test load. The samples should be left and the deflections measured every 5 min until the difference between two consecutive sets of readings is less than 2 % with regard to the first set of the two consecutive sets of readings. The samples should sustain the increased loading without collapsing. Buckling and deformation of the samples is permissible at this loading.

Note: Alternatively, tests can be carried out:

- at any temperature within the declared range if documentation is available which states that the relevant structural properties of the materials as used within the system do not differ by more than 5% of the average between the maximum and minimum property values, or,
- only at maximum temperature within the range, if documentation is available, which states that the relevant structural properties of the materials, as used within the system decrease when the temperature is increasing, or
- at maximum and minimum temperature only. Tests should be carried out for the smallest and largest sizes of cable trays lengths or cable ladder lengths, having the same material, joint and topological shape.

2.26.2 Fire Properties

2.26.2.1 Flame Retardant Test

The cable trays/protective casings should be at least flame retardant. They should be tested in accordance with item 2.24 of this Publication.

2.26.2.2 Smoke and Toxicity Test

The cable tray/protective casings should be tested in accordance with Part 2 of 2010 FTP Code adopted by IMO Resolution MSC.307(88) as amended by IMO Resolution MSC.437(99), or any international or national standard.

2.26.3 Special Requirements

2.26.3.1 Resistivity Test

Cable trays/protective casings of plastic materials passing through a hazardous area should not be electrically non-conductive and should ensure satisfactory earthing between any point in these appliances and the ship's hull.

The volume resistivity level of the cable trays/protective casings and fittings should be below 10^5 ohm meter [Ωm] and the surface resistivity should be below 10^8 ohm [Ω]. The cable tray/protective casings should be tested in accordance with IEC 62631-3-1:2016 and IEC 62631-3-2:2015.

Appendix 1 IEC 61537:2006 Loading Test Procedure Summary

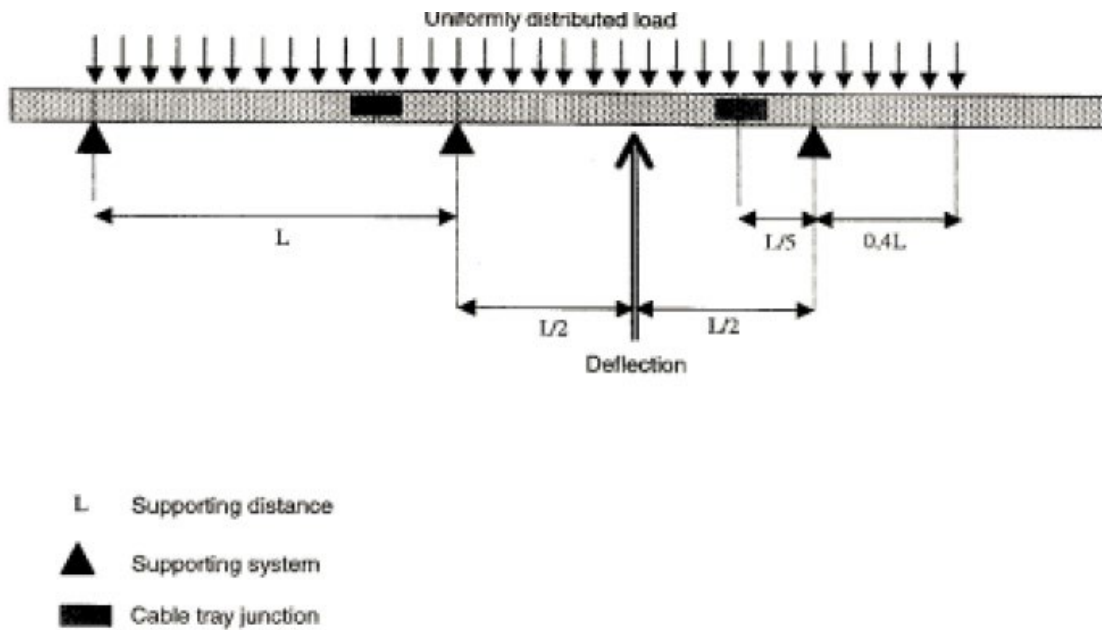

List of amendments as of 1 July 2024

Item	Title/Subject	Source
1.2.6.1.2.7	Update of requirements	UR E10 (Rev.9 Aug 2023) UL
2.15	Update of requirements	UR E10 (Rev.9 Aug 2023) UL
2.20	Update of requirements	UR E10 (Rev.9 Aug 2023) UL
2.26.3.1	Update of requirements	Rec 73 (Rec.3 Dec 2023) UL