



**RULES
FOR THE CLASSIFICATION AND CONSTRUCTION
OF SEA-GOING SHIPS**

**PART VI
SHIP AND MACHINERY PIPING SYSTEMS**

July
2024

GDAŃSK

RULES FOR THE CLASSIFICATION AND CONSTRUCTION OF SEA-GOING SHIPS developed and edited by Polish Register of Shipping* consist of the following Parts:

- Part I – Classification Regulations
- Part II – Hull
- Part III – Hull Equipment
- Part IV – Stability and Subdivision
- Part V – Fire Protection
- Part VI – Ship and Machinery Piping Systems
- Part VII – Main and Auxiliary Machinery and Equipment
- Part VIII – Electrical Installations and Control Systems
- Part IX – Materials and Welding

Part VI – Ship and Machinery Piping Systems – July 2024 was approved by PRS Executive Board on 13 June 2024 and enters into force on 1 July 2024.

From the entry into force, the requirements of *Part VI* apply, within the full scope, to new ships.

For existing ships, the requirements of *Part VI* are applicable within the scope specified in *Part I – Classification Regulations*.

The requirements of this *Part VI* are extended by the below-listed *Publications*:

- Publication 4/P – I.C. Engines and Engine Components – Survey and Certification
- Publication 9/P – Requirements for Computer Based Systems
- Publication 10/P – Safety requirements for sea-going fishing vessels
- Publication 12/P – Safety requirements for sea-going ships carrying industrial personnel
- Publication 72/P – Safety requirements for ships using low flashpoint gases as fuel
- Publication 78/P – Guidelines for Exhaust Gas-SO_x Cleaning Systems
- Publication 90/P – Safe Return to Port and Orderly Evacuation and Abandonment of the Ship,
- Publication 100/P – Safety requirements for sea-going passenger ships and high-speed passenger craft engaged in domestic voyages
- Publication 102/P – European Union Recognized Organizations Mutual Recognition Procedure for Type Approval
- Publication 103/P – Guidelines on Ship Energy Efficiency.
- Publication 115/P – Alternative Certification Scheme for Classification of Ship Machinery Equipment and Materials
- Publication 116/P – Bunkering Guidelines for LNG as Marine Fuel
- Publication 122/P – Requirements for Baltic Ice Class Ships and Polar Class for Ships under PRS Supervision

External documents referred to in this *Part VI* (IMO Resolutions and Circulars, IACS Resolutions, international standards, etc.) – see *List of external reference documents* at the end of the text.

© Copyright by Polish Register of Shipping, 2024

* Polish Register of Shipping means Polski Rejestr Statków S.A., seated in Gdańsk, al. gen. Józefa Hallera 126, 80-416 Gdańsk, Poland, registered in the Register of Entrepreneurs of the National Court Register, under entry number 0000019880. Polish Register of Shipping, its affiliates and subsidiaries, their respective officers, employees or agents are, individually and collectively, referred to as Polish Register of Shipping or as PRS for short.

CONTENTS

CHAPTER 1	7
1 GENERAL PROVISIONS	7
1.1 Application and explanation	7
1.2 Definitions	8
1.3 Technical documentation of ship	15
1.4 Scope of survey	16
1.5 Rules for pipes	18
1.6 Rules for piping design, construction and testing	24
1.7 Production and application of plastic piping systems on ships*	51
1.8 Openings and penetrations in watertight structures	63
1.9 Penetrations in fire-resisting divisions and prevention of heat transmission	65
1.10 Arrangement of systems	66
1.11 Insulation of pipes and ducts	67
1.12 Protection against corrosion	68
1.13 Protection against overpressure	68
1.14 Valves and instrumentation	69
1.15 Sea chests	70
1.16 Ambient conditions	70
CHAPTER 2	73
2 DRAINAGE SYSTEMS	73
2.1 General requirements	73
2.2 Scuppers	73
2.3 Bilge systems	76
2.4 Drainage of various spaces	79
CHAPTER 3	86
3 OIL RESIDUE SYSTEM	86
3.1 Oil residue (sludge) tank	86
3.2 Standard discharge connection	88
CHAPTER 4	89
4 BALLAST AND ANTI-HEELING SYSTEMS	89
4.1 Pumps and tanks	89
4.2 Pipe diameters	90
4.3 Arrangement of pipes and connections	90
4.4 Anti-heeling arrangements	90
4.5 Ballast water and sediments management systems	91
CHAPTER 5	126
5 AIR AND SOUNDING PIPES	126
5.1 Air pipes – general requirements	126
5.2 Strength requirements for air pipes on fore deck	128
5.3 Air pipe closing devices	130
5.4 Sounding pipes – general requirements	138
5.5 Sounding pipes and arrangements for oil tanks	138

CHAPTER 6	141
6 EXHAUST GAS SYSTEMS	141
6.1 Exhaust gas lines.....	141
6.2 Spark arresters and silencers.....	142
6.3 Exhaust gas cleaning systems.....	142
6.4 Storage and use of SCR reductants.....	142
6.5 Safety measures against chemical treatment fluids used for exhaust gas cleaning systems and the residues which have hazardous properties.....	144
CHAPTER 7	149
7 VENTILATION SYSTEMS	149
7.1 General requirements.....	149
7.2 Ducts, dampers, penetrations – fire considerations.....	149
7.3 Separation of ventilation systems, ducts passage through various spaces.....	151
7.4 Details of fire dampers and duct penetrations in fire divisions.....	152
7.5 Closing appliances and stopping devices of ventilation.....	153
7.6 Ventilation of machinery spaces.....	154
7.7 Ventilation of control stations outside machinery spaces.....	156
7.8 Ventilation of the emergency fire pump space.....	157
7.9 Ventilation of the storage rooms of fire-extinguishing medium.....	157
7.10 Ventilation of battery rooms and battery lockers.....	157
7.11 Ventilation of cargo spaces.....	158
7.12 Exhaust ducts from galley ranges in cargo ships.....	159
7.13 Ventilation systems of cargo vessels of less than convention size.....	159
CHAPTER 8	160
8 FUEL SYSTEMS	160
8.1 Limitations in the use of oil as fuel.....	160
8.2 Oil fuel tanks.....	161
8.3 Oil fuel bunkering and overflow arrangements.....	164
8.4 Heating arrangements in oil fuel tanks.....	165
8.5 Water draining arrangements for oil fuel tanks.....	166
8.6 Oil fuel leakage collecting arrangements.....	166
8.7 Oil fuel transfer pumps and piping arrangements.....	167
8.8 Oil fuel piping arrangements.....	168
8.9 Oil fuel supply to oil fuelled machinery.....	169
8.10 Recommendation for fuel oil treatment systems.....	171
8.11 The use of low flash-point fuels other than oil fuel.....	183
8.12 Oil fuel arrangements of cargo vessels of less than convention size.....	183
8.13 Arrangements for gaseous fuel for domestic purpose.....	183
CHAPTER 9	184
9 LUBRICATING OIL SYSTEMS	184
9.1 General requirements.....	184
9.2 Pumps serving internal combustion engines, their gears and couplings.....	185
9.3 Lubricating oil supply to internal combustion engines and gears.....	185
9.4 Pumps serving steam turbines and their gears.....	186
9.5 Lubricating oil supply to steam turbines and their gears.....	187
9.6 Lubricating oil tanks.....	188
9.7 Arrangement of pipes.....	188

CHAPTER 10	189
10 OTHER OIL SYSTEMS	189
10.1 General requirements	189
10.2 Thermal oil systems	189
10.3 Hydraulic oil systems	191
CHAPTER 11	194
11 COOLING WATER SYSTEMS	194
11.1 Pumps.....	194
11.2 Arrangement of pipes and connections	195
11.3 Cooling water strainers.....	195
11.4 Cooling of internal combustion engines.....	195
CHAPTER 12	197
12 COMPRESSED AIR SYSTEMS	197
12.1 Starting arrangements of internal combustion engines.....	197
12.2 Arrangements for bringing machinery into operation from dead ship condition	199
12.3 Starting arrangements for emergency generating sets	199
12.4 Arrangement of pipes and connections	200
CHAPTER 13	201
13 BOILER FEED WATER SYSTEM	201
13.1 Pumps.....	201
13.2 Arrangement of pipes and connections	201
13.3 Tanks.....	202
CHAPTER 14	203
14 STEAM SYSTEM, BOILER SCUM AND BLOW-DOWN SYSTEM	203
14.1 Arrangement of pipes and connections	203
14.2 Draining of steam pipelines.....	203
CHAPTER 15	205
15 CONDENSATE SYSTEM AND STEAM SUPPLY SYSTEM FOR STEAM TURBINES	205
15.1 General requirements for condensate system	205
15.2 Cooling water and condensate pumps	205
15.3 Arrangement of pipes and connections	205
15.4 Steam supply to steam turbines	206
CHAPTER 16	208
16 SANITARY DRAINAGE SYSTEM	208
16.1 General requirements	208
16.2 Sewage system	208
CHAPTER 17	212
17 ADDITIONAL REQUIREMENTS FOR SPECIFIC SHIP TYPES	212
17.1 Passenger ships – additional marks: PASSENGER SHIP, PASSENGER SHIP (FERRY).....	212
17.2 Container ships – additional mark CONTAINER SHIP	220
17.3 Roll on-roll off ships – additional marks: RO-RO SHIP, RO-RO SHIP (FERRY), VEHICLE CARRIER	220
17.4 Bulk carriers and combination carriers – additional marks: BULK CARRIER, SELF-UNLOADING BULK CARRIER, ORE CARRIER, CEMENT CARRIER, ORE CARRIER/CRUDE OIL TANKER, BULK CARRIER/ORE CARRIER/CRUDE OIL TANKER.....	227
17.5 General cargo ships – additional marks: DRY CARGO SHIP, CEMENT CARRIER	229

17.6	Oil tankers – additional marks: CRUDE OIL TANKER, PRODUCT CARRIER A, PRODUCT CARRIER B	229
17.7	Chemical tankers – additional mark CHEMICAL TANKER	251
17.8	Gas tankers – additional mark LIQUEFIED GAS TANKER	258
17.9	Oil spill response vessels – additional mark OIL RECOVERY VESSEL	258
17.10	Chemical spill response vessels – additional mark CHEMICAL RECOVERY VESSEL	260
17.11	Special purpose ships – additional marks: SPECIAL PURPOSE SHIP, CREW BOAT, RESEARCH SHIP, TRAINING SHIP	262
17.12	Fishing vessels – additional mark FISHING VESSEL.....	263
17.13	Offshore vessels – additional marks: TUG, SUPPLY VESSEL	263
CHAPTER 18		264
18 ADDITIONAL REQUIREMENTS FOR SPECIFIC STRUCTURES, SYSTEMS OR EQUIPMENT		264
18.1	Ships using low-flashpoint gas fuels – additional marks: IGF DF, IGC DF	264
18.2	Ships operating in ice – additional marks of Baltic ice class: L1A, L1, L2, L3 (L4); additional marks of Polar class: PC1, PC2, PC3, PC4, PC5, PC6, PC7	264
18.3	Periodically unattended machinery spaces – additional mark AUT	264
18.4	Energy efficient ships – additional mark ECO EF	267
SUPPLEMENT – RETROACTIVE REQUIREMENTS		268
1 GENERAL		268
2 REQUIREMENTS		268
ANNEX I – LIST OF EXTERNAL REFERENCE DOCUMENTS		269

CHAPTER 1

1 GENERAL PROVISIONS

1.1 Application and explanation

1.1.1 *Part VI – Ship and Machinery piping systems* of the *Rules* contains requirements for ship and machinery piping and ventilation systems (hereinafter referred to collectively as systems) and applies to all ship types to be assigned the main symbol ***KM** or ***K** of PRS class. Additional requirements for the assignment of additional marks in the symbol of class related to a specific ship type, specific structures, systems or equipment, are provided in *Chapter 17* and *Chapter 18* of this *Part VI*.

1.1.2 Requirements of this *Part VI* cover the systems' components i.e. pipes, ducts, valves, fittings (joints, supports, etc.), associated machines and devices (pumps, compressors, fans, independent tanks, coolers, heaters, etc.), as well as insulation and shielding of the systems, if any.

1.1.3 Requirements for the systems' associated machines and devices given in this *Part VI* concern only their type, number, capacity, etc. while requirements for their design and construction are provided in *Part VII – Main and Auxiliary Machinery and Equipment*.

1.1.4 Requirements concerning materials for the systems' components are provided in *Part IX – Materials and Welding*.

1.1.5 Requirements for piping systems forming an integral part of any piece of machinery or equipment are usually specified together with the requirements for such machinery or equipment in relevant *Parts* of the *Rules*.

1.1.6 Requirements for firefighting and fire detection systems are provided in *Part V – Fire Protection*.

1.1.7 Requirements for refrigerating plants to be assigned the symbol ***Ch** of PRS class and for non-classed refrigerating plants are provided in *Part VII* of the *Rules*.

1.1.8 Requirements for ships to be assigned additional mark of subdivision in their symbol of class can be found in particular paragraphs of this *Part VI*.

1.1.9 If relaxation from some requirements of this *Part VI* can be granted due to restricted or special service of a ship, relevant information can be found in particular paragraphs.

1.1.10 Requirements of external documents implemented into the *Rules* are marked with dedicated colours (see 1.1.11, 1.1.13 and 1.1.14) and provided with identification of the source material they came from. PRS' text is always in black colour.

1.1.11 Latest editions of **IACS resolutions (Unified Requirements – UR, Unified Interpretations – UI and Recommendations – REC.)** concerning systems are incorporated and cited in this *Part VI* in their original version where appropriate. Whenever the term Classification Society or Society appears in IACS resolutions it should be read as PRS. Unless explicitly provided otherwise IACS Recommendations are non-mandatory.

1.1.12 IACS UIs will be applied by PRS to ships whose flag Administrations have not issued definite instructions on the interpretation of the IMO regulations concerned.

1.1.13 Statutory technical requirements of **SOLAS**, **MARPOL**, **Load Lines (LL)** and **BWM** Convention as well as of related IMO resolutions and circulars concerning systems are

incorporated and cited in this *Part VI* in their original version where appropriate. Only the latest version of statutory requirements is cited.

1.1.14 Relevant provisions of **EU legal documents (Directives, Regulations, Decisions)** concerning systems are incorporated and cited in this *Part VI* in their original version where appropriate.

1.1.15 If some parts of the cited IACS resolutions or statutory technical requirements have been omitted due to their irrelevance in particular context, the omitted text is marked with (...). Where necessary, relevant PRS notes or additional requirements are inserted in the cited text in black colour.

1.1.16 Statutory technical requirements incorporated into the *Rules* will be applied to ships as stipulated in the Conventions they come from. For ships of less than convention size for which the flag Administration has not defined its own national “statutory” requirements, PRS will apply requirements of these *Rules* as far as reasonable and practicable to ensure appropriate level of safety and environment protection taking into account both the type and service area of the ship.

1.1.17 Statutory technical requirements cited in the *Rules* will not be considered as the condition for class assignment if PRS provides statutory services and certification to the ship on behalf of her flag Administration.

1.1.18 If following the provisions of a Convention flag Administration exempts a ship from any of the Convention technical requirements or accepts equivalent arrangements PRS will not demand compliance with the Convention original technical requirements cited in these *Rules*.

1.1.19 Whenever Conventions leave some technical arrangements to the satisfaction of flag Administrations PRS, acting as RO on behalf of a flag Administration, will make relevant decisions following provisions of Agreement with the Administration, otherwise will accept decisions made by the RO acting on behalf of the flag Administration. If the flag Administration of a newbuilding is unknown (not decided yet) PRS will make relevant decisions on its own.

1.1.20 PRS, when accepting alternative design and arrangements to those required by IMO instruments and this *Part VI* will act in accordance with SOLAS regulation II-1/55 and related MSC.1/Circ.1212/Rev.1 and MSC.1/Circ.1455 as may be amended. Necessary engineering analysis shall be submitted to PRS for evaluation and approval while examinations/tests required for the purpose of such analysis shall be witnessed by PRS Surveyor.

1.2 Definitions

The following definitions apply mainly for the purpose of this *Part VI*. For definitions of other terms used in this *Part* see either *Part I* or the relevant referenced *Parts* of the *Rules*.

- .1 **Accommodation spaces** – see *Part V*, 1.2.2.
- .2 **“A” class divisions** – see *Part V*, 1.2.2.
- .3 **Active substance** means a substance or organism, including a virus or a fungus, that has a general or specific action on or against harmful aquatic organisms and pathogens. (BWM, Reg. A-1.7)
- .4 **Auxiliary machinery** – machinery providing for the operation of main engines, supply of the ship with electric and other power, as well as for the operation of shipboard systems and arrangements.
- .5 **B – moulded breadth of the ship**, [m] – the greatest breadth measured between the outer edges of frames.

- .6 **Breadth (B)** is the greatest moulded breadth of the ship at or below the deepest subdivision draught. (SOLAS, Reg. II-1/2.8)
- .7 **Ballast water management** means mechanical, physical, chemical, and biological processes, either singularly or in combination, to remove, render harmless, or avoid the uptake or discharge of harmful aquatic organisms and pathogens within ballast water and sediments. (BWM, Reg. Article 1.3)
- .8 **“B” class divisions** – see *Part V*, 1.2.4.
- .9 **Bulkhead deck in a passenger ship** means the uppermost deck:
 - .1 to which the main bulkheads and the ship's shell are carried watertight, for ships subject to the provisions of regulation II-1/1.1.1.1; and
 - .2 at any point in the subdivision length (L_s) to which the main bulkheads and the ship's shell are carried watertight and the lowermost deck from which passenger and crew evacuation will not be impeded by water in any stage of flooding for damage cases defined in regulation 8 and in part B-2 of this chapter, for ships not subject to the provisions of regulation II-1/1.1.1.1 but constructed on or after 1 January 2009.

The bulkhead deck may be a stepped deck. In a **cargo ship** not subject to the provisions of regulation II-1/1.1.1.1 but constructed on or after 1 January 2009, the freeboard deck may be taken as the bulkhead deck. (SOLAS, Reg. II-1/3.19)

Note:
Ships subject to the provisions of regulation II-1/1.1.1.1 are those ships to which the *Rules* apply.
- .10 **Burst pressure** – the inside static pressure at which a flexible hose assembly or expansion joint will be destroyed.
- .11 **Cargo area** is that part of the ship that contains cargo holds, cargo tanks, slop tanks and cargo pump-rooms including pump-rooms, cofferdams, ballast and void spaces adjacent to cargo tanks and also deck areas throughout the entire length and breadth of the part of the ship over the above-mentioned spaces. (SOLAS, Reg. II-2/3.6)
- .12 **A cargo ship** is any ship which is not a passenger ship. (SOLAS, Reg. I/2g)
- .13 **Cargo spaces** are spaces used for cargo, cargo oil tanks, tanks for other liquid cargo and trunks to such spaces. (SOLAS, Reg. II-2/3.8)
- .14 **Clean ballast** means the ballast in a tank which since oil was last carried therein, has been so cleaned that effluent therefrom if it were discharged from a ship which is stationary into clean calm water on a clear day would not produce visible traces of oil on the surface of the water or on adjoining shorelines or cause a sludge or emulsion to be deposited beneath the surface of the water or upon adjoining shorelines. If the ballast is discharged through an oil discharge monitoring and control system approved by the Administration, evidence based on such a system to the effect that the oil content of the effluent did not exceed 15 parts per million shall be determinative that the ballast was clean, notwithstanding the presence of visible traces. (MARPOL, Reg. I/1.17)
- .15 **Closed ro-ro spaces** are ro-ro spaces which are neither open ro-ro spaces nor weather decks. (SOLAS, Reg. II-2/3.12)
- .16 **Closed vehicle spaces** are vehicle spaces which are neither open vehicle spaces nor weather decks. (SOLAS, Reg. II-2/3.13)
- .17 **Contracted for construction** – whenever the term appears in any IACS PR it shall be understood as the date on which the contract to build the vessel is signed between the

prospective owner and the shipbuilder. For further details regarding the date of “contract for construction”, refer to IACS PR29.

.18 Control station (type of station for machinery control):

- **automatic** – a position which ensures automatic adaptation of machinery operation parameters for maintaining the set operation program and/or performance of set sequence without intervention of operators;
- **local** – a position fitted with operating controls, instrumentation and – in the case of necessity – means of communication, located in close vicinity to or directly on the machine;
- **remote** – a position from which remote adjustment of working parameters, as well as possible remote starting and stopping the engines and machinery is possible.

.19 Control stations are those spaces in which the ship's radio or main navigating equipment or the emergency source of power is located or where the fire recording or fire control equipment is centralized. (SOLAS, Reg. II-1/3.18)

Note:

This definition applies to SOLAS Chapter II-1 regulations cited in the *Rules*.

.20 Control stations are those spaces in which the ship's radio or main navigating equipment or the emergency source of power is located or where the fire recording or fire control equipment is centralized. Spaces where the fire recording or fire control equipment is centralized are also considered to be a "fire control station". (SOLAS, Reg. II-2/3.18)

Note:

This definition applies to SOLAS Chapter II-2 regulations cited in the *Rules*.

IACS and IMO interpretation

- 1 *Main navigational equipment includes, in particular, the steering stand and the compass, radar and position-finding equipment.*
- 2 *Steering gear rooms containing an emergency steering position are not considered to be control stations.*
- 3 *Where in the regulations of chapter II-2 relevant to fixed fire-extinguishing systems there are no specific requirements for the centralization within a control station of major components of a system, such major components may be placed in spaces which are not considered to be a control station.*
- 4 *Spaces containing, for instance, the following battery sources should be regarded as control stations regardless of battery capacity:*
 - .1 *emergency batteries in separate battery room for power supply from black-out till start of emergency generator;*
 - .2 *emergency batteries in separate battery room as reserve source of energy to radiotelegraph installation;*
 - .3 *batteries for start of emergency generator;*
 - .4 *and, in general, all emergency batteries required in pursuance of Reg. II-1/42 or II-1/43. (IACS UI SC17, MSC/Circ.1120)*

.21 Crude oil means any liquid hydrocarbon mixture occurring naturally in the earth whether or not treated to render it suitable for transportation and includes:

- .1 crude oil from which certain distillate fractions may have been removed; and
- .2 crude oil to which certain distillate fractions may have been added. (MARPOL, Reg. I/1.2)

.22 Dead ship condition is the condition under which the main propulsion plant, boilers and auxiliaries are not in operation due to the absence of power. (SOLAS, Reg. II-1/3.8)

.23 Design pressure – see 1.5.2.8

- .24 Design temperature** – see 1.5.2.9
- .25 Engine control room (ECR)** – enclosed space which contains: a central control station of main engines and auxiliary machinery and of controllable pitch propellers or thrusters, control devices, instrumentation, alarms giving warning of reaching the limits of the permissible assumed parameters, alarms announcing the activation of automatic protection devices, means of communication.
- .26 Engine room** – machinery space where main engines and auxiliary machinery are fitted.
- .27 Essential auxiliary boilers** – boilers supplying with steam the auxiliary machinery and equipment necessary for ship motion and safety of navigation if there are no other sources of power to keep these machinery and equipment operational in the case of the boilers shutdown.
- .28 Expansion joint** – a short length of metallic or non-metallic tube, generally of the bellows type, provided with end fittings, for absorption of axial loads where angular and/or lateral flexibility has to be ensured.
- .29 Flexible hose assembly** – see 1.6.12.1.1.
- .30 Freeboard deck** is the deck as defined in the *International Convention on Load Lines in force*. (SOLAS, Reg. II-1/2.6)
- .31 The freeboard deck** is normally the uppermost complete deck exposed to weather and sea, which has permanent means of closing all openings in the weather part thereof, and below which all openings in the sides of the ship are fitted with permanent means of watertight closing. (LL, Annex 1, Reg. I/3(9)(a))
- Note:**
For remaining parts of the definition: (b) Lower deck as freeboard deck and (c) Discontinuous freeboard deck, stepped *freeboard deck* – see the *International Convention on Load Lines*.
- .32 IGF Code** means the *International Code of safety for ships using gases or other low-flashpoint fuels* as adopted by the Maritime Safety Committee of the Organization by resolution MSC.391(95), as may be amended by the Organization, provided that such amendments are adopted, brought into force and take effect in accordance with the provisions of article VIII of the present Convention concerning the amendment procedures applicable to the annex other than chapter I. (SOLAS, Reg. II-1/2.28)
- .33 L – Length of the ship**, [m] – 96% of the total length on a waterline at 85% of the moulded depth, measured from the base plane, or the length from the fore side of the stem to the axis of the rudder stock on that waterline, if that be greater. In ships designed with a rake of keel, the waterline on which this length is measured shall be parallel to the design waterline. In ships with unusual stern and bow arrangement, length *L* is subject to special consideration by PRS according to the *International Convention on Load Lines* in force.
- .34 Length (L)** is the length as defined in the *International Convention on Load Lines* in force. (SOLAS, Reg. II-1/2.5)
- Note:**
In principle this length *L* is the length of the ship defined in .33.
- .35 L – the Rule length L** is the distance, in metres, measured on the waterline at the scantling draught from the fore side of the stem to the after side of the rudder post, or the centre of the rudder stock if there is no rudder post. *L* is not to be less than 96%, and need not be greater than 97%, of the extreme length on the waterline at the scantling draught.
- In ships without rudder stock (e.g. ships fitted with azimuth thrusters), the Rule length *L* is to be taken equal to 97% of the extreme length on the waterline at the scantling draught.

In ships with unusual stern and bow arrangement the *Rule length L* will be specially considered. (IACS UR S2, para. S2.1)

- .36 L_w – Length of summer load waterline**, [m] – the distance measured at this waterline from the fore side of the stem to the point of intersection of the waterline with after side of the stern (transom).
- .37 Low-flashpoint fuel** means gaseous or liquid fuel having a flashpoint lower than otherwise permitted under 8.1.1 (regulation II-2/4.2.1.1). (SOLAS, Reg. II-1/2.29)
- Note:**
Flashpoint permitted under 8.1.1 (regulation II-2/4.2.1.1) is not less than 60°C.
- .38 Machinery spaces of category A** are those spaces and trunks to such spaces which contain:
- .1** internal combustion machinery used for main propulsion;
 - .2** internal combustion machinery used for purposes other than main propulsion where such machinery has in the aggregate a total power output of not less than 375 kW; or
 - .3** any oil-fired boiler or oil fuel unit. (SOLAS, Reg. II-1/3.17)
- Note:**
This definition applies to all SOLAS Chapter II-1 regulations concerning *machinery spaces of category A* cited in this *Part VI*.
- .39 Machinery spaces of category A** are those spaces and trunks to such spaces which contain either:
- .1** internal combustion machinery used for main propulsion;
 - .2** internal combustion machinery used for purposes other than main propulsion where such machinery has in the aggregate a total power output of not less than 375 kW; or
 - .3** any oil-fired boiler or oil fuel unit, or any oil-fired equipment other than boilers, such as inert gas generators, incinerators, etc. (SOLAS, Reg. II-2/3.31)
- Note:**
This definition applies to all SOLAS Chapter II-2 regulations cited in this *Part VI* and other non-SOLAS requirements of this *Part VI* concerning *machinery spaces of category A*.
- .40 Machinery spaces** are all machinery spaces of category A and all other spaces containing propelling machinery, boilers, oil fuel units, steam and internal combustion engines, generators and major electrical machinery, oil filling stations, refrigerating, stabilizing, ventilation and air conditioning machinery, and similar spaces, and trunks to such spaces. (SOLAS, Reg. II-1/3.16)
- .41 Main engines** – machinery intended for the ship propulsion such as internal combustion engines, steam and gas turbines, steam engines, electric motors, etc.
- .42 Oil** means petroleum in any form including crude oil, fuel oil, sludge, oil refuse and refined products (other than those petrochemicals which are subject to the provisions of Annex II of the present Convention) and, without limiting the generality of the foregoing, includes the substances listed in appendix I to this Annex. (MARPOL, Reg. I/1.1)
- .43 Oil fuel** means any oil used as fuel in connection with the propulsion and auxiliary machinery of the ship in which such oil is carried. (MARPOL, Reg. I/1.4)
- .44 Oil fuel unit** is the equipment used for the preparation of oil fuel for delivery to an oil-fired boiler, or equipment used for the preparation for delivery of heated oil to an internal

combustion engine, and includes any oil pressure pumps, filters and heaters dealing with oil at a pressure of more than 0.18 N/mm². (SOLAS, Reg. II-2/3.34)

IACS and IMO interpretation

Oil fuel unit includes any equipment used for the preparation and delivery of oil fuel, heated or not, to boilers (including inert gas generators) and engines (including gas turbines) at a pressure of more than 0.18 N/mm². Oil fuel transfer pumps are not considered as oil fuel units. (IACS UI SC16, MSC.1/Circ.1203)

.45 Oil residue (sludge) means the residual waste oil products generated during the normal operation of a ship such as those resulting from the purification of fuel or lubricating oil for main or auxiliary machinery, separated waste oil from oil filtering equipment, waste oil collected in drip trays, and waste hydraulic and lubricating oils. (MARPOL, Reg. I/1.31)

Note:

This definition does not apply to the residual waste oil products from cargo area in oil tankers.

.46 Oil residue (sludge) tank means a tank which holds oil residue (sludge) from which sludge may be disposed directly through the standard discharge connection or any other approved means of disposal. (MARPOL, Reg. I/1.32)

.47 Oily bilge water means water which may be contaminated by oil resulting from things such as leakage or maintenance work in machinery spaces. Any liquid entering the bilge system including bilge wells, bilge piping, tank top or bilge holding tanks is considered oily bilge water. (MARPOL, Reg. I/1.33)

Note:

This definition does not cover water originating from cargo tanks, slop tanks and cargo pump rooms in oil tankers.

.48 Oily bilge water holding tank means a tank collecting oily bilge water prior to its discharge, transfer or disposal. (MARPOL, Reg. I/1.34)

.49 Oily mixture means a mixture with any oil content. (MARPOL, Reg. I/1.3)

.50 Open deck spaces are Open deck spaces and enclosed promenades clear of lifeboat and liferaft embarkation and lowering stations. To be considered in this category, enclosed promenades shall have no significant fire risk, meaning that furnishings shall be restricted to deck furniture. In addition, such spaces shall be naturally ventilated by permanent openings. Air spaces (the space outside superstructures and deckhouses). (SOLAS, Reg. II-2/9.2.2.3.2.(5))

.51 Open ro-ro spaces are those ro-ro spaces that are either open at both ends or have an opening at one end, and are provided with adequate natural ventilation effective over their entire length through permanent openings distributed in the side plating or deckhead or from above, having a total area of at least 10% of the total area of the space sides. (SOLAS, Reg. II-2/3.35)

.52 Open vehicle spaces are those vehicle spaces either open at both ends, or have an opening at one end and are provided with adequate natural ventilation effective over their entire length through permanent openings distributed in the side plating or deckhead or from above, having a total area of at least 10% of the total area of the space sides. (SOLAS, Reg. II-2/3.36)

.53 A passenger ship is a ship which carries more than twelve passengers. (SOLAS, Reg. I/2f)

.54 Ro-ro spaces are spaces not normally subdivided in any way and normally extending to either a substantial length or the entire length of the ship in which motor vehicles with fuel in their tanks for their own propulsion and/or goods (packaged or in bulk, in or on rail or

road cars, vehicles (including road or rail tankers), trailers, containers, pallets, demountable tanks or in or on similar stowage units or other receptacles) can be loaded and unloaded normally in a horizontal direction. (SOLAS, Reg. II-2/3.41)

- .55 *Safety centre*** is a control station (see .20) dedicated to the management of emergency situations. Safety systems' operation, control and/or monitoring are an integral part of the safety centre. (SOLAS, Reg. II-2/3.52)
- .56 *Sanitary drainage*** – sewage and greywater drainage, according to the following definitions:

Sewage means:

- .1** drainage and other wastes from any form of toilets and urinals;
- .2** drainage from medical premises (dispensary, sick bay, etc.) via wash basins, wash tubs and scuppers located in such premises;
- .3** drainage from spaces containing living animals; or
- .4** other waste waters when mixed with the drainages defined above. (MARPOL, Reg. II/1.3)

Note:

Sewage can be also referred to as *blackwater*.

Greywater means:

- .1** drainage from wash basins, wash tubes, showers and scuppers located in premises containing such utensils, provided that the scuppers do not drain black water (i.e. they are separated by means of a tight sill from the part of the premises where toilets and/or urinals are located),
 - .2** drainage from laundry,
 - .3** drainage from sinks from washing of food, cooking utensils, dishes, etc.
- .57 *Segregated ballast*** means the ballast water introduced into a tank which is completely separated from the cargo oil and oil fuel system and which is permanently allocated to the carriage of ballast or to the carriage of ballast or cargoes other than oil or noxious liquid substances as variously defined in the Annexes of the present Convention. (MARPOL, Reg. II/1.18)
- .58 *Service spaces*** are those spaces used for galleys, pantries containing cooking appliances, lockers, mail and specie rooms, storerooms, workshops other than those forming part of the machinery spaces, and similar spaces and trunks to such spaces. (SOLAS, Reg. II-2/3.45)
- .59 *Similar stage of construction*** – the stage at which construction identifiable with a specific ship begins and assembly of that ship has commenced comprising at least 50 tonnes or one per cent (1%) of the estimated mass of all structural material, whichever is lesser.
- .60 *Slop tank*** means a tank specifically designated for the collection of tank drainings, tank washings and other oily mixtures. (MARPOL, Reg. II/1.16)
- .61 *Special category spaces*** are those enclosed vehicle spaces above and below the bulkhead deck, into and from which vehicles can be driven and to which passengers have access. Special category spaces may be accommodated on more than one deck provided that the total overall clear height for vehicles does not exceed 10 m. (SOLAS, Reg. II-2/3.46)
- .62 *Systems*** – ship and machinery piping and ventilation systems.

.63 *A tanker* is a cargo ship constructed or adapted for the carriage in bulk of liquid cargoes of an inflammable* nature. (SOLAS, Reg. I/2h)

* "Inflammable" has the same meaning as "flammable"

.64 *Vehicle spaces* are cargo spaces intended for carriage of motor vehicles with fuel in their tanks for their own propulsion. (SOLAS, Reg. II-2/3.49)

.65 *Watertight* means having scantlings and arrangements capable of preventing the passage of water in any direction under the head of water likely to occur in intact and damaged conditions. In the damaged condition, the head of water is to be considered in the worst situation at equilibrium, including intermediate stages of flooding. (SOLAS, Reg. II-1/2.17)

.66 *Weather deck* is a deck which is completely exposed to the weather from above and from at least two sides. (SOLAS, Reg. II-2/3.50)

.67 *Weathertight* means that in any sea conditions water will not penetrate into the ship. (SOLAS, Reg. II-1/2.16)

.68 *Working pressure* – the highest permissible pressure during normal course of long lasting operation.

1.3 Technical documentation of ship

1.3.1 Prior to the commencement of the ship construction the below listed technical documentation shall be submitted to PRS Head Office for consideration and approval. In the case of ships, which undergo modifications the below listed documentation is subject to consideration and approval in the scope which covers the modifications.

1.3.2 The documentation shall contain all the information (e.g. material specifications, list of system's components and their technical data, calculations, pressure tests) necessary to consider it for compliance with these *Rules*.

1.3.3 Documentation of piping systems to be submitted to PRS Head Office for consideration and approval:

- .1 diagrams of drainage systems (deck scuppers and bilge system);
- .2 diagram of oil residue system;
- .3 diagrams of ballast and anti-heeling systems;
- .4 diagrams of air and sounding pipes;
- .5 diagrams of exhaust gas systems (including drawings of silencers and spark arresters);
- .6 diagrams of heating, ventilation and air conditioning systems (HVAC);
- .7 diagrams of fuel systems (fuel oil and other alternative fuels);
- .8 diagrams of lubricating oil systems;
- .9 diagram of thermal oil system;
- .10 diagrams of hydraulic oil power systems;
- .11 diagrams of cooling water systems;
- .12 diagrams of compressed air systems;
- .13 diagrams of boiler feed water and condensate systems;

- .14 diagrams of boiler scum and blow-down system, as well as steam machinery and pipelines blow-through system;
- .15 diagrams of steam power systems;
- .16 diagrams of steam systems for heating, steaming and blow-through of tanks, sea chests, systems, fittings, etc.;
- .17 drawings of bottom and side sea chests fittings;
- .18 diagrams of sanitary systems (sanitary drainage, sewage treatment, sanitary and fresh water supply);
- .19 diagrams of ship type specific piping systems (e.g. for tankers);
- .20 diagrams of toxic gas systems;
- .21 diagrams of gaseous fuel system for domestic purposes.

Diagrams of piping systems passing through ship's shell plating, watertight decks or bulkheads or fire divisions shall present arrangements ensuring that the ship watertight and fire integrity is not impaired.

1.4 Scope of survey

1.4.1 Piping systems, whose documentation is subject to consideration and approval, are surveyed during the ship construction or modification.

1.4.2 Manufacturing of pipes, valves, fittings and associated components (pumps, compressors, independent tanks, coolers, heaters, etc.) intended for piping systems of class I and II (see 1.6.2), as well as manufacturing of bottom and side valves and fittings, valves and fittings installed on collision bulkhead and remote controlled valves and fittings, is subject to PRS survey.

1.4.3 Products mentioned in 1.4.2 shall have either *Test Certificate/Inspection Certificate* or *Type Approval Certificate* issued by PRS. All PRS certificates should be accompanied by the manufacturer's documents specifying the results of performed tests and additionally in the case of type approved products be provided with the manufacturer statement confirming compliance of the product with the approved type. See also 1.4.7 to 1.4.9.

1.4.4 In lieu of *Type Approval Certificate* issued by PRS, PRS may accept *Type Approval Certificate* issued by any European Union Recognised Organisation (EU RO) in accordance with the provisions of *Publication 102/P – European Union Recognized Organizations Mutual Recognition Procedure for Type Approval*.

1.4.5 Products other than those mentioned in 1.4.2 should have documents issued by the manufacturer specifying the results of performed tests and/or confirming compliance with the approved type as appropriate.

1.4.6 Piping systems after installation on board the ship, should be subjected to acceptance tests in accordance with the programmes agreed with PRS.

1.4.7 In ships which are certified according to SOLAS and MARPOL Convention and which fly the flag of an EU Member State, the below specified marine equipment is subject to the conformity assessment procedures as regards its design, construction and performance requirements and to testing standards set out in Commission Implementing Regulation (EU) 2022/1157, laying down rules for the application of Directive 2014/90/EU (so called MED Directive):

- .1 Penetrations through 'A' class divisions: pipe, duct, trunk, etc. penetrations (MED/3.26b);**

- .2 Penetrations through 'B' class divisions: pipe, duct, trunk, etc. penetrations (MED/3.27b);
 - .3 Materials other than steel for pipes conveying oil or fuel oil:
 - plastic pipes and fittings (MED/3.15a),
 - valves (MED/3.15b),
 - flexible hose assemblies and compensators (MED/3.15c),
 - metallic pipe components with resilient and elastomeric seals (MED/3.15d);
 - .4 Oil-filtering equipment (for an oil content of the effluent not exceeding 15 p.p.m.) (MED/2.1);
 - .5 Oil/water interface detectors (MED/2.2);
 - .6 Oil-content meters (MED/2.3);
 - .7 Oil discharge monitoring and control system for oil tankers (MED/2.5);
 - .8 Sewage systems (for use by passenger ships in all areas, including a MARPOL Annex IV special area). (MED/2.6a);
 - .9 Sewage systems (for use by ships, other than passenger ships, in all areas and by passenger ships outside MARPOL Annex IV special areas). (MED/2.6b);
 - .10 Shipboard incinerators (Incinerator plants with capacities up to 4 000kW) (MED/2.7);
 - .11 NO_x analyser permanently placed on board and for use on board as per *NO_x Technical Code 2008* (MED/2.8);
 - .12 On board exhaust gas cleaning systems (MED/2.10);
 - .13 Devices to prevent the passage of flame into the cargo tanks in tankers:
 - P/V valves (MED/3.12a),
 - flame arresters (MED/3.12b),
 - detonation flame arresters (MED/3.12c),
 - high velocity vent valves (MED/3.12d);
 - .14 Fire door control systems components (MED/3.17);
 - .15 Fire dampers (MED/3.22);
 - .16 Water level detectors (MED/8.1);
- 1.4.8** The following marine equipment for which the set of standards for MED certification is not complete, shall be of the type approved by PRS:
- .1 Equipment using other equivalent methods to reduce on board NO_x emissions (MED/9/2.3);
 - .2 Equipment using other technological methods to limit SO_x emissions (MED/9/2.4);
 - .3 On board NO_x analysers using a measurement method other than the Direct Measurement and Monitoring Method of the *NO_x Technical Code 2008* (MED/9/2.5);
 - .4 Gaseous Fuel Systems Used for Domestic Purposes (components) (MED/9/3.26);
 - .5 Flexible hoses suitable for methyl/ethyl alcohol for fuel piping systems (MED/9/3.75);

- .6 Vapour outlets suitable for methyl/ethyl alcohol fuel tanks (MED/9/3.76).** (Annex to Regulation (EU) 2022/1157)

1.4.9 For ships of less than 500 gross tonnage and for passenger ships not engaged on international voyages, as well as for ships flying the flag of non-EU Member State, the equipment specified in 1.4.7, shall be of a type approved by PRS (should have *Type Approval Certificate*).

In lieu of *Type Approval Certificate*, the above-mentioned equipment may have *EC Declaration of Conformity* with the MED Directive.

1.5 Rules for pipes

IACS UR P1

1.5.1 Scope (P1.1)

This requirement is applicable to all piping systems covered by classification unless superseded by other UR and interpretation applicable to specific piping systems.

Chemical cargo and process piping are excluded from the scope of the present requirement.

1.5.2 Strength of pipes (P1.2)

1.5.2.1 Required wall thickness (P1.2.1)

The minimum wall thickness of pipes is not to be less than the greater of the values obtained by 1.5.2.2 and 1.5.2.4 (P1.2.2, P1.2.3), as applicable, or the minimum wall thickness required by 1.5.2.5 (P1.2.4).

1.5.2.2 Calculated wall thickness (P1.2.2)

The following requirements apply for pipes where the ratio outside-diameter to inside-diameter does not exceed the value 1.7.

The calculated wall thickness for straight or bent pressure pipes is not to be less than determined from the following formula, as applicable:

$$t = t_0 + b + c \quad (1)$$

where t = minimum calculated thickness(mm)

t_0 = thickness calculated by the following basic formula (mm)

$$t_0 = \frac{PD}{20Ke + P} \quad (2)$$

P = design pressure (bar) (see 1.5.2.8 (P1.2.7))

D = outside diameter (mm)

K = permissible stress (N/mm²) (from 1.5.2.6 (P1.2.5) and 1.5.2.7 (P1.2.6))

e = efficiency factor

(i) $e = 1$ for seamless pipes and for welded pipes delivered by manufacturers approved for making welded pipes which are considered an equivalent to seamless pipes.

(ii) for other welded pipes the Classification Society will consider an efficiency factor value depending upon the service and the welding procedure.

b = allowance for bending

The value for this allowance is to be chosen in such a way that the calculated stress in the bend, due to the internal pressure only, does not exceed the permissible stress.

When this allowance is not determined by a more accurate procedure, it is to be taken as not less than:

$$b = \frac{1}{2.5} \frac{D}{R} t_0 \quad (3)$$

where R = mean radius of the bend (mm)
 c = corrosion allowance (mm) (from Tables 1 and 2)

1.5.2.3 The mean radius of bend of steel and copper pipes subjected to a pressure exceeding 0.5 MPa or to a temperature of the internal medium exceeding 60°C, as well as the radius of bend of the pipes intended for self-expansion shall not be less than 2.5D (D – outside diameter of the pipe).

If, during the bending, no reduction of the pipe wall thickness occurs, then – subject to PRS acceptance of the bending process in each particular case – the specified radius may be reduced.

1.5.2.4 Manufacturing tolerance (P1.2.3)

The value of t , calculated above, does not account for any negative manufacturing tolerance; therefore the said thickness shall be increased considering the negative manufacturing tolerance by means of the following formula:

$$t_1 = \frac{t}{1 - a/100} \quad (4)$$

where t_1 = minimum thickness in the case of negative tolerance (mm)
 t = minimum thickness calculated by formula (1) (mm)
 a = percentage negative manufacturing tolerance.

1.5.2.5 Minimum wall thickness (P1.2.4)

The minimum wall thickness is to be as indicated in Tables 3-6. For pipes subject also to Load Line Regulations see LL36 (see 2.2.13).

Table 1 Corrosion allowance c for steel pipes

Piping service	c (mm)
Superheated steam systems	0,3
Saturated steam systems	0,8
Steam coil systems in cargo tanks	2
Feed water for boilers in open circuit systems	1,5
Feed water for boilers in closed circuit systems	0,5
Blow down (for boilers) systems	1,5
Compressed air systems	1
Hydraulic oil systems	0,3
Lubricating oil systems	0,3
Fuel oil systems	1
Cargo oil systems	2
Refrigerating plants	0,3
Fresh water systems	0,8
Sea water systems in general	3

NOTE

1. For pipes passing through tanks an additional corrosion allowance is to be considered according to the figures given in the Table, and depending on the external medium, in order to account for the external corrosion.
2. The corrosion allowance may be reduced where pipes and any integral pipe joints are protected against corrosion by means of coating, lining, etc.
3. In the case of use of special alloy steel with sufficient corrosion resistance, the corrosion allowance may be reduced to zero.

Table 2 Corrosion allowance *c* for non-ferrous metal pipes

Piping material	<i>c</i> (mm)
Copper, brass and similar alloys, copper-tin alloys except those with lead contents	0,8
Copper-nickel alloys (with Ni ≥ 10%)	0,5

NOTE
For media without corrosive action in respect of the material employed and in the case of special alloys with sufficient corrosion resistance the corrosion allowance may be reduced to zero.

Table 3 Minimum wall thickness for steel pipes (All dimensions in mm)

Nominal size	Outside diameter	Wall thickness			
		A	B	C	D
6	10,2	1,6			
	12	1,6			
8	13,5	1,8			
10	17,2	1,8			
	19,3	1,8			
	20	2			
15	21,3	2		3,2	
	25	2		3,2	
20	26,9	2		3,2	
25	33,7	2		3,2	
	38	2	4,5	3,6	6,3
32	42,4	2	4,5	3,6	6,3
	44,5	2	4,5	3,6	6,3
40	48,3	2,3	4,5	3,6	6,3
	51	2,3	4,5	4	6,3
50	60,3	2,3	4,5	4	6,3
	63,5	2,3	4,5	4	6,3
	70	2,6	4,5	4	6,3
65	76,1	2,6	4,5	4,5	6,3
	82,5	2,6	4,5	4,5	6,3
80	88,9	2,9	4,5	4,5	7,1
90	101,6	2,9	4,5	4,5	7,1
	108	2,9	4,5	4,5	7,1
100	114,3	3,2	4,5	4,5	8
	127	3,2	4,5	4,5	8
	133	3,6	4,5	4,5	8
125	139,7	3,6	4,5	4,5	8
	152,4	4	4,5	4,5	8,8
150	168,3	4	4,5	4,5	8,8
	177,8	4,5	5	5	8,8
175	193,7	4,5	5,4	5,4	8,8
200	219,1	4,5	5,9	5,9	8,8
225	244,5	5	6,3	6,3	8,8
250	273	5	6,3	6,3	8,8
	298,5	5,6	6,3	6,3	8,8

300	323,9	5,6	6,3	6,3	8,8
350	355,6	5,6	6,3	6,3	8,8
	368	5,6	6,3	6,3	8,8
400	406,4	6,3	6,3	6,3	8,8
450	457,2	6,3	6,3	6,3	8,8

Notes of Table 3

Columns A, B, C and D in the table apply to the following services:

- A Pipes in general
- B Vent, overflow and sounding pipes for integral tanks
- C Bilge, ballast and sea water pipes
- D Bilge, ballast, vent, overflow and sounding pipes passing through fuel tank. Bilge, vent, overflow, sounding and fuel pipes passing through ballast tanks.

Notes:

1. The nominal sizes, pipe diameters and wall thicknesses given in the table are many of the common sizes based on international standards. Notwithstanding the requirements of Table 3, diameter and thickness according to other national or international standards may be accepted.
2. Where pipes and any integral pipe joints are protected against corrosion by means of coating, lining etc. at the discretion of the Classification Society, the thickness may be reduced by not more than 1 mm.
3. For sounding pipes, except those for flammable cargoes, the minimum wall thickness in column B is intended to apply only to the part outside the tank.
4. The minimum thicknesses listed in this table are the nominal wall thickness. No allowance needs to be made for negative tolerance or for reduction in thickness due to bending.
5. For threaded pipes, where allowed, the minimum wall thickness is to be measured at the bottom of the thread.
6. The minimum wall thickness for bilge lines and ballast lines through deep tanks will be subject to special consideration by the Classification Society. The minimum wall thickness for ballast lines through oil cargo tanks is not to be less than that specified by UR F15 (see 17.6.2.6).
7. The minimum wall thickness for pipes larger than 450 mm nominal size is to be in accordance with a national or international standard and in any case not less than the minimum wall thickness of the appropriate column indicated for 450 mm pipe size.
8. The minimum internal diameter for bilge, sounding, venting and overflow pipes shall be:
 - Bilge 50 mm bore
 - Sounding 32 mm bore
 - Venting and overflow 50 mm bore
9. Exhaust gas pipe minimum wall thickness will be subject to special consideration by the Classification Society.
- 9A. Minimum wall thickness of exhaust pipes should not be less than 4 mm.
10. The minimum wall thickness for cargo oil lines will be subject to special consideration by the Classification Society.

Table 4 Minimum wall thickness for austenitic stainless steel pipes

External diameter <i>D</i> (mm)	Minimum wall thickness (mm)	External diameter <i>D</i> (mm)	Minimum wall thickness (mm)
10.2 to 17.2	1.0	219.1	2.6
21.3 to 48.3	1.6	273.0	2.9
60.3 to 88.9	2.0	323.9 to 406.4	3.6
114.3 to 168.3	2.3	over 406.4	4.0

Note: Diameters and thicknesses according to national or international standards may be accepted.

Table 5 Minimum wall thickness for steel pipes for CO₂ fire extinguishing

External diameter <i>D</i> (mm)	From bottles to distribution station	From distribution station to nozzles
21,3 – 26,9	3,2	2,6
30 – 48,3	4	3,2
51 – 60,3	4,5	3,6
63,5 – 76,1	5	3,6
82,5 – 88,9	5,6	4
101,6	6,3	4

108 – 114,3	7,1	4,5
127	8	4,5
133 – 139,7	8	5
152,4 – 168,3	8,8	5,6

NOTES

1. Pipes are to be galvanized at least inside, except those fitted in the engine room where galvanizing may not be required at the discretion of the Classification Society.
2. For threaded pipes, where allowed, the minimum wall thickness is to be measured at the bottom of the thread.
3. The external diameters and thicknesses have been selected from ISO Recommendations R336 for smooth welded and seamless steel pipes. Diameter and thickness according to other national or international standards may be accepted.
4. For larger diameters the minimum wall thickness will be subject to special consideration by the Classification Society.
5. In general the minimum thickness is the nominal wall thickness and no allowance need be made for negative tolerance or reduction in thickness due to bending.

Table 6 Minimum wall thickness for copper and copper alloy pipes

External diameter D (mm)	Minimum wall thickness (mm)	
	Copper	Copper alloy
8 – 10	1	0,8
12 – 20	1,2	1
25 – 44,5	1,5	1,2
50 – 76,1	2	1,5
88,9 – 108	2,5	2
133 – 159	3	2,5
193,7 – 267	3,5	3
273 – 457,2	4	3,5
(470)	4	3,5
508	4,5	4

Note
The external diameters and the thicknesses have been selected from ISO Standards.
Diameter and thickness according to other national or international standards may be accepted.

1.5.2.6 Permissible stress K for carbon steel and alloy steel pipes (P1.2.5)

The permissible stress for carbon steel and alloy steel pipes to be considered in formula (2) of 1.5.2.2 (P1.2.2) is to be chosen as the lowest of the following values:

$$R_{20}/2,7$$

$$E_T/1,6 \text{ up to } E_T/1,8$$

$$\sigma_{R/100\,000}/1,6 \text{ up to } \sigma_{R/100\,000}/1,8$$

$$\sigma_{1/100\,000}/1 \text{ accordingly.}$$

where R_{20} = specified minimum tensile strength (N/mm²) at room temperature, i.e. 20°C
 E_T = specified minimum yield stress or 0,2% proof stress (N/mm²) at the design temperature (see 1.5.2.9 (P1.2.8))
 $\sigma_{R/100\,000}$ = average stress (N/mm²) to produce rupture in 100 000 hours at the design temperature (see 1.5.2.9 (P1.2.8))
 $\sigma_{1/100\,000}$ = average stress (N/mm²) to produce 1% creep in 100 000 hours at the design temperature (see 1.5.2.9 (P1.2.8))

Notes

1. The values of yield stress or 0,2% proof stress given by national and international standards for steel pipes may be adopted.

2. The values in the range between 1,6 and 1,8 are to be chosen at the discretion of the Classification Society.
3. The value of $\sigma_{1/100\ 000}/1$ may be used at discretion of the Classification Society on the basis of its reliability, and if deemed necessary.

1.5.2.7 Permissible stress K for copper and copper alloys (P1.2.6)

The permissible stress for copper and copper alloy pipes to be considered in formula (2) of 1.5.2.2 (P1.2.2) is to be taken from Table 7, depending upon design temperature (see 1.5.2.9 (P1.2.8)).

Table 7 Permissible stress limits K for copper and copper alloys

Pipe material	Copper	Aluminium brass	Copper nickel Cu Ni 5 Fe 1 Mn Cu Ni 10 Fe 1 Mn	Copper nickel Cu Ni 30
Material condition	Annealed	Annealed	Annealed	Annealed
Minimum tensile strength (N/mm ²)	215	325	275	365
Permissible stress K (N/mm ²)	50°C	41	78	81
	75°C	41	78	79
	100°C	40	78	77
	125°C	40	78	65,5
	150°C	34	78	64
	175°C	27,5	51	62
	200°C	18,5	24,5	59
	225°C	-	-	56
	250°C	-	-	52
	275°C	-	-	48
300°C	-	-	44	
NOTES				
1. Intermediate values may be determined by linear interpolation.				
2. For materials not included in the Table, the permissible stress shall be specially considered by the Classification Society.				

1.5.2.8 Design pressure (P1.2.7)

The design pressure P to be considered in formula (2) of 1.5.2.2 (P1.2.2) is the maximum working pressure and it is not to be less than the highest set pressure of any safety relief valve. For special cases, the design pressure will be specially considered. For pipes containing fuel oil, the design pressure is to be taken in accordance with Table 8.

Table 8 Definition of the design pressure for fuel oil systems

Working Pressure	Working temperature	
	$T \leq 60^\circ\text{C}$	$T > 60^\circ\text{C}$
$P \leq 7$ bar	3 bar or max. working pressure, whichever is the greater	3 bar or max. working pressure, whichever is the greater
$P > 7$ bar	max. working pressure	14 bar or max. working pressure, whichever is the greater

1.5.2.9 Design temperature (P1.2.8)

The design temperature to be considered for determining the permissible stress in 1.5.2.6 (P1.2.5) and 1.5.2.7 (P1.2.6) is in general the maximum temperature of the medium inside the pipes. For special cases, the design temperature will be specially considered.

1.5.3 Flanges (P1.3)

The dimensions of flanges and relative bolts are to be chosen in accordance with the national standards. For special application the dimensions of flanges and relative bolts will be subject to special consideration*.

** For special applications, when the temperature, the pressure and the size of the flange have values above certain limits, to be fixed, the complete calculation of bolts and flanges is to be carried out.*

1.5.4 Valves and Fittings (P1.4)

Valves and fittings in piping systems are to be compatible with the pipes to which they are attached in respect of their strength (see 1.5.2.8 (P1.2.7) for design pressure) and are to be suitable for effective operation at the maximum working pressure they will experience in service.

END OF IACS UR P1

1.6 Rules for piping design, construction and testing

IACS UR P2

1.6.1 Foreword (P2.1)

The present requirements are related to piping-systems made of carbon, carbon-manganese, alloy steels or non-ferrous material normally installed on board ships for services considered in Table 1.

These requirements cover the following services:

Air, vapour, gas (excluding liquefied gas cargo and process piping), water, lubricating oil, fuel oil, hydraulic fluid systems for steering gear, toxic gas and liquids, cargo oil and tank cleaning piping and open ended lines such as drains, overflows, vents and boiler escape pipes.

They do not include pipes forming integral part of a boiler.

Hydraulic fluid systems other than those for steering gear shall be specially considered by each individual Classification Society.

Piping systems intended for liquefied gases (cargo and process) are dealt with in UR G3 and W1 (see PRS' *Rules for the Classification and Construction of Sea-going Gas Tankers*).

These requirements do not apply to cargo piping systems of ships carrying chemicals in bulk.

Note:

See also *Part IX*: 2.11 – for ductility tests for pipes and tubes, 10 – for the requirements for steel tubes and 17.1 – for the requirements for copper and copper alloy tubes.

1.6.2 Classes of pipes (P2.2)

For the purpose of testing, the type of joint to be adopted, heat treatment and welding procedure, pipes are subdivided into three classes as indicated in Figure 1 and Table 1.

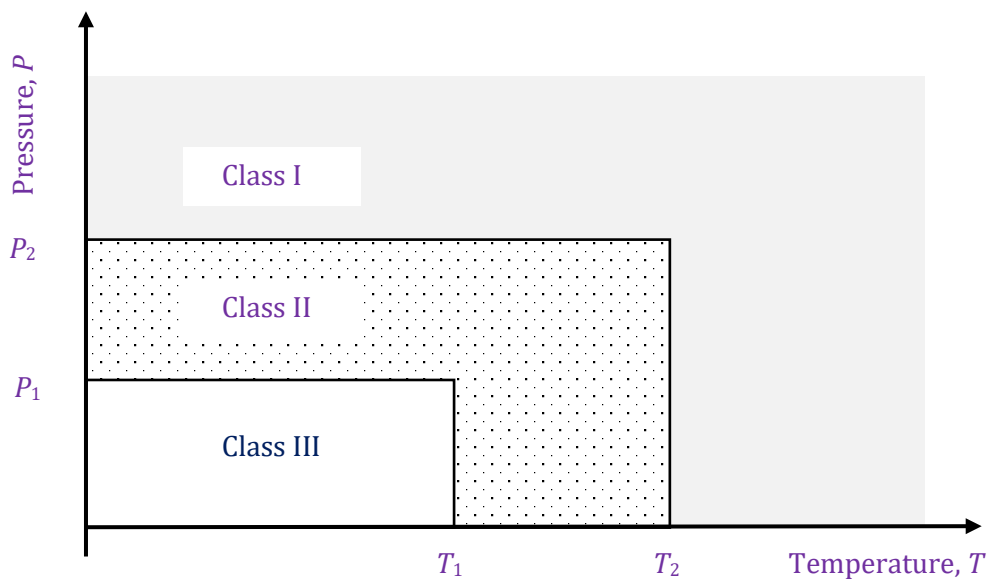

Figure 1

Table 1

Piping System for	Class I $P >$ or $T >$	Class II	Class III $P \leq$ & $T \leq$
Toxic or corrosive media	Without special safeguards	With special safeguards (1, 2)	Not applicable
Flammable media heated above flash point or with flash point below 60°C	Without special safeguards	With special safeguards (1)	Not applicable
Liquified Gas			
Steam	16 300	Any pressure-temperature combination not belong to Class I or III	7 170
Thermal Oil	16 300		7 150
Fuel Oil			
Lubricating Oil	16 150		7 60
Flammable Hydraulic Oil			
Other media (5, 6)	40 300		16 200

Notes:

- Safeguards for reducing leakage possibility and limiting its consequences:
e.g. pipes led to positions where leakage of internal fluids will not cause a potential hazard or damage to surrounding areas which may include the use of pipe ducts, shielding, screening, etc.
- Class II pipes are not to be used for toxic media
- Cargo oil pipes belong to Class III
- P = Design pressure (bar), as defined in 1.5.2.8 (P1.2.7); T = Design temperature (°C), as defined in 1.5.2.9 (P1.2.8)
- Including water, air, gases, non-flammable hydraulic oil
- Open ended pipes (drains, overflows, vents, exhaust gas lines, boiler escape pipes) irrespective of T , belong to Class III

1.6.3 Materials (P2.3)

The materials to be used for the various pipes, valves and fittings are to be suitable for the medium and service for which the piping is intended (see 1.6.3.1 to 1.6.3.4 (P2.3.1 to P2.3.4)).

In the case of especially corrosive media, the materials for the piping system will be considered by the Classification Society in each particular case.

Note:

See also: 1.8.2.2 (SOLAS Reg. II-1/12.6.1) – for valves and fittings on collision bulkhead, 1.8.4.9 (SOLAS Reg. II-1/15.8.5) and 2.2.12 (LL, Annex 1, Reg. II/22(6)) – for valves and fittings on shell plating and 8.8.4 (SOLAS Reg. II-2/4.2.2.5.1) – for pipes, valves and fittings in oil fuel, lubricating oil and other flammable oils systems.

1.6.3.1 Steel pipes, valves and other fittings (P2.3.1)

Pipes belonging to Classes I and II are to be seamless drawn steel pipes or pipes fabricated with a welding procedure, considered by the Society to be equivalent to seamless pipes.

In general, carbon and carbon-manganese steel pipes, valves and other fittings are not to be employed for temperatures above 400°C. Nevertheless, they may be used for higher temperatures if their metallurgical behaviour and time dependent strength (UTS after 100 000 hours) are in accordance with national or international codes or standards and if such valves are guaranteed by the steel manufacturer. Otherwise, special alloy steel pipes, valve and fittings should be employed according to Rules on materials of the Classification Society.

Pipes, valves and fittings of low alloy steel may be used for media with temperature not exceeding 500°C and those made of alloy steel may be used for media with temperature exceeding 500°C.

1.6.3.2 Copper and copper alloy pipes, valves and fittings (P2.3.2)

Copper and copper alloy piping shall be of seamless drawn material or other type approved by the Classification Society.

Copper pipes for Classes I and II are to be seamless.

In general, copper and copper alloy piping, valves and fittings shall not be used for media having temperature above the following limits:

- .1 Copper and aluminium brass 200°C
- .2 Copper nickel 300°C

(see Table 6 in 1.5.2.5 (of P1)).

Special bronze suitable for high temperature services may be accepted in general up to 260°C.

Copper and copper alloy piping, valves and fittings shall not be used for fuel oil and for ammonia (NH₃).

1.6.3.3 Nodular cast iron pipes, valves and other fittings (P2.3.3)

Nodular cast iron of the ferritic type according to the material rules of the Classification Society may be accepted for bilge, ballast and cargo oil piping.

Ferritic nodular cast iron valves and other fittings may be accepted for media having temperatures not exceeding 350°C.

The use of this material for pipes, valves and fittings for other services, in principle Classes II and III, will be subject to special consideration.

Nodular cast iron pipes and valves fitted on the ship's side should have specified properties to the Classification Society's satisfaction, according to the intention of 2.2.2 to 2.2.13 (Regulation 22 of the 1966 Convention on Load Lines).

1.6.3.4 Ordinary cast iron pipes, valves and fittings (P2.3.4)

Ordinary cast iron pipes, valves and fittings may be accepted in principle for Class III at the Classification Society's judgement.

Ordinary cast iron piping may be accepted for cargo oil lines within cargo tanks of tankers.

Ordinary cast iron is not to be used for pipes, valves and other fittings handling media having temperature above 220°C and for piping subject to pressure shock, excessive strains and vibrations.

Ordinary cast iron may be accepted for pressures up to 16 bar for cargo oil pipelines on weather decks of oil tankers except for manifolds and their valves and fittings connected to cargo handling hoses.

Ordinary cast iron shall not be used for sea valves and pipes fitted on the ship sides, and for valves fitted on the collision bulkhead.

The use of cast iron for other services will be subject to special consideration in each case.

1.6.4 Testing of Materials (P2.4)

Material for pipes, valves and relative fittings belonging to Classes I and II and for valves and pipes fitted on the ship's side and for valves fitted on the collision bulkhead are to be tested in accordance with applicable Rules of the individual Classification Society.

The individual Classification Society may require internal workshop certificates for pipes, valves and fittings belonging to Class III.

1.6.5 Welding (P2.5)

1.6.5.1 General (P2.5.1)

The welding joints belonging to Class I or II piping systems shall be effected by approved procedures. Consumables and welders shall meet the requirements of the Classification Society's Rules.

Joint preparations and tolerance shall be appropriate to the welding process, in accordance with the Classification Society's Rules or recognized standards.

Welding shall be done according to applicable requirements and good practice; the weld preparations and the welded joint shall be inspected as may be necessary in the course of fabrication and after completion of the welding heat treatment. For non-destructive tests, see 1.6.6 (P2.6).

The following requirements apply to the fabrication of Classes I and II piping systems operating at ambient or high temperature and made of steel of the types given hereunder:

- .1 carbon and carbon-manganese steels having minimum tensile strength (R_m) 320, 360, 410, 460 and 490 N/mm².
- .2 low alloy carbon-molybdenum, chromium-molybdenum, chromium-molybdenum-vanadium steels having chemical composition 0,3 Mo; 1 Cr - 0,5 Mo; 2,25 Cr - 1 Mo; 0,5 Cr - 0,5 Mo - 0,25 V.

At the discretion of the Society, these requirements may be applied also to the Class III piping systems and to repair welding of pipelines.

Refrigerated cargo installations piping systems operating at temperatures lower than -40°C will be given special consideration by each Society.

1.6.5.2 Agreeing welding procedures

- .1 Welding procedures for class I and II piping systems are subject to PRS agreement.
- .2 The welding procedure is to detail all of the parameters necessary to effect sound welds. Prior to commencement of welding, the Works should be granted with the recognition for welding on the basis of appropriate tests. The tests should include:
 - welding processes,
 - parent materials,
 - welding consumables,
 - edge preparation,
 - welding position.
- .3 The procedure tests should be performed in conditions adequately representative of those actually used in the production welding. Scope of non-destructive testing – see 1.6.6 below.
- .4 The following tests are required from each test assembly:
 - transverse tensile tests,
 - bend tests (1 – face bend and 1 – root bend or 1 – side bend).
- .5 Macro section with hardness survey, Charpy V-notch impact tests in weld metal and heat affected zone, chemical analysis of the deposited metal in case of alloy steels may also be required at the discretion of PRS.
- .6 Unless otherwise specified the results of tensile tests are to comply with the parent material requirements.
- .7 Bend specimens are to be bent around a mandrel having a diameter 4 times the thickness of the specimen with an angle of 180° . Superficial cracks less than 3 mm in length should not be taken into consideration.
- .8 PRS may wholly or partially dispense with procedure approval test where the required weld properties are demonstrated by other means to the PRS satisfaction.

1.6.5.3 Welding facilities and personnel

Piping systems are to be manufactured by Works having the necessary equipment, qualified personnel and implemented technological process for the construction of welded piping.

1.6.5.4 Edge preparation for welded joints (P2.5.2)

Edge preparation is to be in accordance with recognized standards and/or approved drawings.

The preparation of the edges shall be preferably carried out by mechanical means. When flame cutting is used, care should be taken to remove the oxide scales and any notch due to irregular cutting by matching grinding or chipping back to sound metal.

1.6.5.5 Alignment and assembling (P2.5.3)

1.6.5.5.1 Unless otherwise agreed by the Society, the tolerances on the alignment of the pipes to be welded are to be as follows:

- .1 Pipes of all diameters and thicknesses welded with permanently fitted backing ring: 0,5 mm.
- .2 Pipes welded without fitted backing ring:
 - .2.1 inside diameter less than 150 mm, thickness up to 6 mm included – 1 mm or $t/4$ whichever is less;
 - .2.2 inside diameter less than 300 mm, thickness up to 9,5 mm included – 1.5 mm or $t/4$ whichever is less;
 - .2.3 inside diameter 300 mm and over, or over thickness 9,5 mm included – 2.0 mm or $t/4$ whichever is less. **(P2.5.3.1)**

NOTE:

For Class III piping systems, the requirements for alignment tolerances may be waived at the discretion of the Society.

1.6.5.5.2 Assembling for welding is to be appropriate and within the prescribed tolerances.

Tack welds should be made with an electrode suitable for the base metal; tack welds which form part of the finished weld should be made using approved procedures.

When welding materials require preheating, the same preheating should be applied during tack welding. **(P2.5.3.2)**

1.6.5.6 Preheating (P2.5.4)

Preheating of the different types of steels will be dependent upon their thickness and chemical composition as indicated in Table 2.

In any case, dryness is to be ensured using, if necessary, suitable preheating.

Table 2 values are based on use of low hydrogen processes; consideration should be given to using higher preheating temperatures when low hydrogen processes are not used.

Table 2

Type of steel		Thickness of thicker part (mm)	Minimum preheating temperature (°C)
C and C/Mn steels	$C + \frac{Mn}{6} \leq 0,40$	≥ 20 ^{2.}	50
	$C + \frac{Mn}{6} > 0,40$	≥ 20 ^{2.}	100
0,3 Mo		> 13 ^{2.}	100
1 Cr – 0,5 Mo		< 13	100
		≥ 13	150
2,25 Cr – 1 Mo and 0,5 Cr – 0,5 Mo – 0,25 V ^{1.}		< 13	150
		≥ 13	200

NOTES:

1. For these materials, preheating may be omitted for thicknesses up to 6 mm if the results of hardness tests carried out on welding procedure qualification are considered acceptable by the Society.
2. For welding in ambient temperature below 0°C, the minimum preheating temperature is required independent of the thickness unless specifically approved by the Classification Society.

1.6.5.7 Heat-treatment after forming and welding (P2.5.5)

1.6.5.7.1 The heat treatments are not to impair the specified properties of the materials; verifications may be required to this effect as necessary.

The heat treatments are preferably to be carried out in suitable furnaces provided with temperature recording equipment. However, also localized heat treatments on a sufficient portion of the length way of the welded joint, carried out with approved procedures, can be accepted. **(P2.5.5.1)**

1.6.5.7.2 Hot forming is to be generally carried out in the temperature range 1000°C - 850°C for all grades; however, the temperature may decrease to 750°C during the forming process.

- .1 When the hot forming is carried out within this temperature range, the following generally applies:
 - .1 for C, C-Mn and C-Mo steels, no subsequent heat treatment is required;
 - .2 for Cr-Mo and C-Mo-V steels, a subsequent stress relieving heat treatment accordance with Table 3 is required.
- .2 When the hot forming is carried outside the above temperature range, a subsequent new heat treatment in accordance with Table 4 is generally required for all grades. **(P2.5.5.2)**

1.6.5.7.3 After cold forming, when $r \leq 4D$ (where r is the mean bending radius and D is the outside diameter of pipe) consideration is to be given to a complete heat treatment in accordance with Table 4; in any case, a stress relieving heat treatment in accordance with Table 3 is required for all grades other than carbon and carbon-manganese steels with (R_m) 320, 360 and 410. **(P2.5.5.3)**

1.6.5.7.4 Stress relieving heat treatment after welding for other than the oxy-acetylene welding process is required as indicated in Table 3 depending on the type of steel and thickness.

The temperature ranges given in the Table are in accordance with common practice. Other values for upper and lower temperature limits may be stipulated by the Society.

The stress relieving heat treatment is to consist in heating the piping slowly and uniformly to a temperature within the range indicated in the Table, soaking at this temperature for a suitable period, in general one hour per 25 mm of thickness with minimum half an hour, cooling slowly and uniformly in the furnace to a temperature not exceeding 400°C and subsequently cooling in a still atmosphere.

In any case, the heat treatment temperature is not to be higher than $t_T - 20^\circ\text{C}$ where t_T is the temperature of the final tempering treatment of the material. **(P2.5.5.4)**

Table 3

Type of steel	Thickness of thicker part (mm)	Stress relief heat treatment temperature (°C)
C and C-Mn	≥ 15 ^{1 & 3.}	550 to 620
0,3 Mo	≥ 15 ^{1.}	580 to 640
1 Cr – 0,5 Mo	> 8	620 to 680
2,25 Cr – 1 Mo and 0,5 Cr – 0,5 Mo – 0,25 V ^{1.}	any ²	650 to 720

NOTES:

1. When steels with specified Charpy V notch impact properties at low temperature are used, the thickness above which postweld heat treatment shall be applied may be increased by special agreement with the Society.
2. Heat treatment may be omitted for pipes having thickness ≤ 8 mm, diameter ≤ 100 mm and minimum service temperature 450°C.
3. For C and C-Mn steels, stress relieving heat treatment may be omitted up to 30 mm thickness by special agreement with the Society.

1.6.5.7.5 Unless otherwise specified, for oxyacetylene welding, the heat treatment indicated in Table 4 depending on the type of steel is required.

The temperature ranges given in the Table are in accordance with common practice. Different values for upper and lower temperature limits may be stipulated by the Society. **(P2.5.5.5)**

Table 4

Type of steel	Heat treatment and temperature (°C)
C and C-Mn	Normalizing 880 to 940
0,3 Mo	Normalizing 900 to 940
1 Cr – 0,5 Mo	Normalizing 900 to 960 Tempering 640 to 720
2,25 Cr – 1 Mo	Normalizing 900 to 960 Tempering 650 to 780
0,5 Cr – 0,5 Mo – 0,25 V	Normalizing 930 to 980 Tempering 670 to 720

1.6.6 Non-destructive testing of welds and acceptance criteria (P2.6)

1.6.6.1 In general, the welded joints including the inside wherever possible shall be visually examined and non-destructive tests will be required depending on the class of pipes and type of joint as hereunder indicated.

In places indicated by the PRS Surveyor, visual inspection is to be supplemented by penetrant or magnetic examination.

- .1** Butt-welded joints - Radiographic examination is to be required as follows:
 - .1.1** pipes of Class I: full radiographic examination when the outside diameter is greater than 75 mm;
 - .1.2** pipes of Class II: at least 10% random radiography when the outside diameter is greater than 100 mm.

More stringent requirements may be applied at the Society's discretion depending on the kind of materials, welding procedure and controls during the fabrication.

An approved ultrasonic testing procedure may be accepted, at the Society's discretion, in lieu of radiographic testing when the conditions are such that a comparable level of weld quality is assured.

- .1** Pipes of Class I – at least 10% random radiography is required when the outside diameter is 75 mm or less, however not less than 1 welded joint made by welder.
- .2** Pipes of Class II – random radiography is required when the outside diameter is 100 mm or less.
- .3** Pipes of Class III – random radiography is required irrespective of the outside diameter.
- .2** Fillet welds of flange pipe connections are to be examined by the magnetic particle method or by other appropriate non-destructive methods, in case of Class I pipes. In other cases, magnetic particle examination or equivalent non-destructive testing may be required at the discretion of the Surveyor.
- .3** Ultrasonic examination in addition to the above non-destructive testing may be required in special cases at the Society's discretion. **(P2.6.1)**

1.6.6.2 Radiographic and ultrasonic examination is to be performed with an appropriate technique by trained operators.

At the request of the Society, complete details of the radiographic or ultrasonic technique is to be submitted for approval. **(P2.6.2)**

1.6.6.3 Magnetic particle examination is to be performed with suitable equipment and procedures, and with a magnetic flux output sufficient for defect detection. The equipment may be required to be checked against standard samples. **(P2.6.3)**

1.6.6.4 The welds are to meet the acceptable standard level as required by the individual Society. Unacceptable defects are to be removed and repaired according to the satisfaction of the Society. **(P2.6.4)**

1.6.7 Types of connections (P2.7)

Direct connections of pipe lengths may be made by direct welding, flanges, threaded joints or mechanical joints, and should be to a recognised standard or of a design proven to be suitable for the intended purpose and acceptable to the Classification Society.

The expression "mechanical joints" means devices intended for direct connection of pipe lengths other than by welding, flanges or threaded joints described in 1.6.7.1, 1.6.7.2 and 1.6.7.3 (2.7.1, 2.7.2 and 2.7.3 below).

1.6.7.1 Welded connections (P2.7.1)

Welding and non-destructive testing of welds are to be carried out in accordance with 1.6.5 (P2.5) and 1.6.6 (P2.6) and requirements of Classification Society.

1.6.7.1.1 Butt welded joints (P2.7.1.1)

Butt welded joints shall be of full penetration type generally with or without special provision for a high quality of root side.*

** The expression "special provision for a high quality of root side" means that butt welds were accomplished as double welded or by use of a backing ring or inert gas back-up on first pass, or other similar methods accepted by the classification society.*

Butt welded joints with special provision for a high quality of root side may be used for piping of any Class, any outside diameter.

Butt welded joints without special provision for a high quality of root side may be used for piping systems of Class II and III irrespective of outside diameter.

1.6.7.1.2 Slip-on sleeve and socket welded joints (P2.7.1.2)

Slip-on sleeve and socket welded joints are to have sleeves, sockets and weldments of adequate dimensions conforming to Classification Society Rules or recognized Standard.

Slip-on sleeve and socket welded joints may be used in Class III systems, any outside diameter.

In particular cases, slip-on sleeve and socket welded joints may be allowed by the Classification Society for piping systems of Class I and II having outside diameter ≤ 88.9 mm except for piping systems conveying toxic media or services where fatigue, severe erosion or crevice corrosion is expected to occur.

1.6.7.2 Flange connections (P2.7.2)

1.6.7.2.1 The dimensions and configuration of flanges and bolts are to be chosen in accordance with recognized standards.

Gaskets are to be suitable for the media being conveyed under design pressure and temperature conditions and their dimensions and configuration are to be in accordance with recognised standards.

Materials containing asbestos shall not be used.

Note:

See also: SOLAS Reg. II-1/3-5.2 (1.11.3), IACS UI SC249 and MSC.1/Circ.1426/Rev.1.

For non-standard flanges the dimensions of flanges and bolts are to be subject to special consideration. (P2.7.2.1)

1.6.7.2.2 Examples of flange attachments are shown in Table 5. However, other types of flange attachments may be considered by the Classification Society in each particular case. (P2.7.2.2)

Table 5 Examples of flange attachments

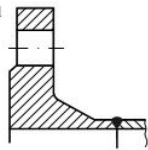
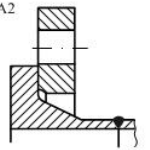
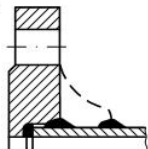
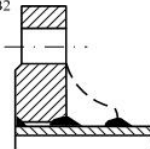
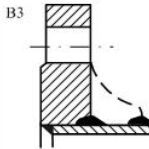
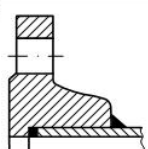
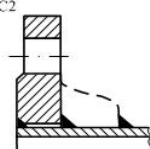
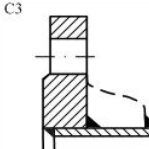
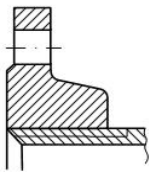
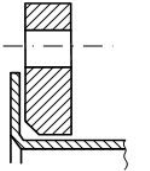
A	A1 	A2 	
B	B1 	B2 	B3 
C	C1 	C2 	C3 
D			
E			

Note:

For type D, the pipe and flange are to be screwed with a tapered thread and the diameter of the screw portion of the pipe over the thread is not to be appreciably less than the outside diameter of the unthreaded pipe. For certain types of thread, after the flange has been screwed hard home, the pipe is to be expanded into the flange.

1.6.7.2.3 Flange attachments are to be in accordance with national or international standards that are applicable to the piping system and are to recognize the boundary fluids, design pressure and temperature conditions, external or cyclic loading and location. (P2.7.2.3)

1.6.7.3 Slip-on threaded joints (P2.7.3)

Slip-on threaded joints having pipe threads where pressure-tight joints are made on the threads with parallel or tapered threads, shall comply with requirements of a recognized national or international standard.

Slip-on threaded joints may be used for outside diameters as stated below except for piping systems conveying toxic or flammable media or services where fatigue, severe erosion or crevice corrosion is expected to occur.

Threaded joints in CO₂ systems shall be allowed only inside protected spaces and in CO₂ cylinder rooms.

Threaded joints for direct connectors of pipe lengths with tapered thread are to be allowed for:

- a) Class I, outside diameter not more than 33.7 mm,
- b) Class II and Class III, outside diameter not more than 60.3 mm.

Threaded joints with parallel thread are to be allowed for Class III, outside diameter not more than 60.3 mm.

In particular cases, sizes in excess of those mentioned above may be accepted by the Classification Society if in compliance with a recognized national and/or international standard.

1.6.7.4 Mechanical joints (P2.7.4)

Due to the great variations in design and configuration of mechanical joints, no specific recommendation regarding calculation method for theoretical strength calculations is given in these requirements. The Type Approval is to be based on the results of testing of the actual joints.

These requirements are applicable to pipe unions, compression couplings, slip-on joints as shown in Table 6. Similar joints complying with these requirements may be acceptable.

1.6.7.4.1 The application and pressure ratings of different mechanical joints are to be approved by the Classification Society. The approval is to be based on the Type Approval procedure in 1.6.11 (P.2.11). Mechanical joints including pipe unions, compression couplings, slip-on joints and similar joints are to be of approved type for the service conditions and the intended application. (P2.7.4.1)

1.6.7.4.2 Where the application of mechanical joints results in reduction in pipe wall thickness due to the use of bite type rings or other structural elements, this is to be taken into account in determining the minimum wall thickness of the pipe to withstand the design pressure. (P2.7.4.2)

1.6.7.4.3 Material of mechanical joints is to be compatible with the piping material and internal and external media. (P2.7.4.3)

1.6.7.4.4 Mechanical joints are to be tested where applicable, to a burst pressure of 4 times the design pressure. For design pressures above 200 bar the required burst pressure will be specially considered by the Classification Society. (P2.7.4.4)

1.6.7.4.5 Where appropriate, mechanical joints are to be of fire resistant type as required by Table 7. (P2.7.4.5)

1.6.7.4.6 Mechanical joints, which in the event of damage could cause fire or flooding, are not to be used in piping sections directly connected to the ship's side below the bulkhead deck of passenger ships and freeboard deck of cargo ships or tanks containing flammable fluids. (P2.7.4.6)

1.6.7.4.7 The number of mechanical joints in flammable fluid systems is to be kept to a minimum. In general, flanged joints conforming to recognised standards are to be used. **(P2.7.4.7)**

1.6.7.4.8 Piping in which a mechanical joint is fitted is to be adequately adjusted, aligned and supported. Supports or hangers are not to be used to force alignment of piping at the point of connection. **(P2.7.4.8)**

1.6.7.4.9 Slip-on joints are not to be used in pipelines in cargo holds, tanks and other spaces which are not easily accessible (refer to MSC/Circ.734), except that these joints may be permitted in tanks that contain the same media.

Usage of slip type slip-on joints as the main means of pipe connection is not permitted except for cases where compensation of axial pipe deformation is necessary. **(P2.7.4.9)**

1.6.7.4.10 Application of mechanical joints and their acceptable use for each service is indicated in Table 7; dependence upon the Class of piping and pipe dimensions is indicated in Table 8.

In particular cases, sizes in excess of those mentioned above may be accepted by the Classification Society if in compliance with a recognized national and/or international standard. **(P2.7.4.10)**

1.6.7.4.11 Mechanical joints are to be tested in accordance with a program approved by the Classification Society, which is to include at least the following:

- .1 leakage test
- .2 vacuum test (where necessary)
- .3 vibration (fatigue) test
- .4 fire endurance test (where necessary)
- .5 burst pressure test
- .6 pressure pulsation test (where necessary)
- .7 assembly test (where necessary)
- .8 pull out test (where necessary) **(P2.7.4.11)**

1.6.7.4.12 The installation of mechanical joints is to be in accordance with the manufacturer's assembly instructions. Where special tools and gauges are required for installation of the joints, these are to be supplied by the manufacturer. **(P2.7.4.12)**

Table 6 Examples of mechanical joints

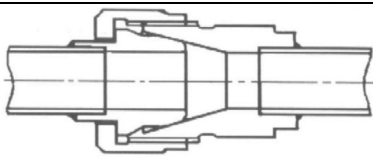
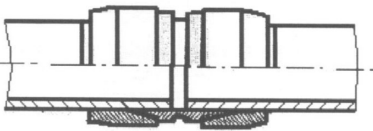
Pipe Unions	
Welded and Brazed Types	
Compression Couplings	
Swage Type	

<p>Press Type</p>	
<p>Typical Compression Type</p>	
<p>Bite Type</p>	
<p>Flared Type</p>	
<p>Slip-on Joints</p>	
<p>Grip Type</p>	
<p>Machine Grooved Type</p>	
<p>Slip Type</p>	

Table 7 Application of mechanical joints

The following table indicates systems where the various kinds of joints may be accepted. However, in all cases, acceptance of the joint type is to be subject to approval for the intended application, and subject to conditions of the approval and applicable Rules. Further, relevant statutory requirements must be taken into consideration. In cases exposure time (t_T) is greater than 30 minutes the dry-wet test conditions are 8 minutes dry and, accordingly, the wet period $t_T - 8$ min.

Systems		Kind of connections			Classification of pipe system	Fire endurance test condition
		Pipe Unions	Compression Couplings	Slip-on Joints		
Flammable fluids (Flash point ≤ 60°C)						
1	Cargo oil lines ¹	+	+	+	dry	30 min dry (*)
2	Crude oil washing lines ¹	+	+	+	dry	
3	Vent lines ³	+	+	+	dry	
Inert Gas						
4	Water seal effluent lines	+	+	+	wet	30 min wet (*)
5	Scrubber effluent lines	+	+	+	wet	30 min wet (*)
6	Main lines ^{1 & 2}	+	+	+	dry	30 min dry (*)
7	Distribution lines ¹	+	+	+	dry	30 min dry (*)
Flammable fluids (Flash point > 60°C)						
8	Cargo oil lines ¹	+	+	+	dry	30 min dry (*)
9	Fuel oil lines ^{2 & 3}	+	+	+	wet	30 min wet (*)
10	Lubricating oil lines ^{2 & 3}	+	+	+	wet	
11	Hydraulic oil ^{2 & 3}	+	+	+	wet	
12	Thermal oil ^{2 & 3}	+	+	+	wet	
Sea Water						
13	Bilge lines ⁴	+	+	+	dry/wet	8 min dry + 22 min wet(*)
14	Permanent water filled fire extinguishing systems, e.g. fire main, sprinkler systems ³	+	+	+	wet	30 min wet (*)
15	Non-permanent water filled fire extinguishing systems, e.g. foam, drencher systems and fire main ³	+	+	+	dry/wet	8 min dry + 22 min wet(*) For foam systems <i>FSS Code</i> Chapter 6 to be observed
16	Ballast system ⁴	+	+	+	wet	30 min wet (*)
17	Cooling water system ⁴	+	+	+	wet	30 min wet (*)
18	Tank cleaning services	+	+	+	dry	Fire endurance test nor required
19	Non-essential systems	+	+	+	dry, dry/wet, wet	Fire endurance test nor required
Fresh Water						
20	Cooling water system ⁴	+	+	+	wet	30 min wet (*)
21	Condensate return ⁴	+	+	+	wet	30 min wet (*)
22	Non-essential system	+	+	+	dry, dry/wet, wet	Fire endurance test nor required
Sanitary/Drains/Scuppers						
23	Deck drains (internal) ⁵	+	+	+	dry	Fire endurance test nor required
24	Sanitary drains	+	+	+	dry	
25	Scuppers and discharge (overboard)	+	+	-	dry	

Sounding/Vent						
26	Water tanks/Dry spaces	+	+	+	dry, wet	Fire endurance test nor required
27	Oil tanks (flash point > 60°C) ^{2 & 3}	+	+	+	dry	Fire endurance test nor required
Miscellaneous						
28	Starting/control air ⁴	+	+	-	dry	30 min dry (*)
29	Service air (non-essential)	+	+	+	dry	Fire endurance test nor required
30	Brine	+	+	+	wet	Fire endurance test nor required
31	CO ₂ system (outside protected space)	+	+	-	dry	30 min dry (*)
32	CO ₂ system (inside protected space)	+	+	-	dry	Mechanical joints shall be constructed of materials with melting point above 925°C. Ref. to FSS Code Chapter 5.
33	Steam	+	+	+ ⁶	wet	Fire endurance test nor required

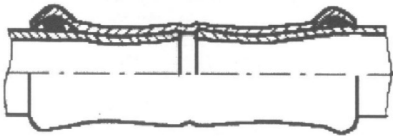
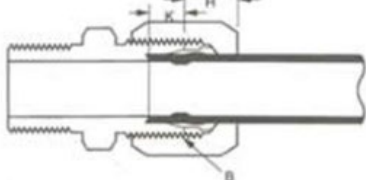
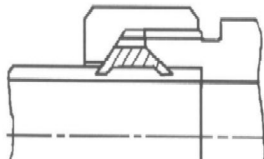
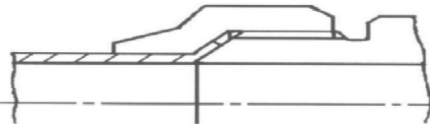
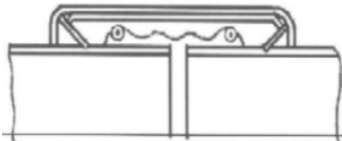
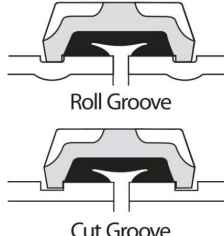
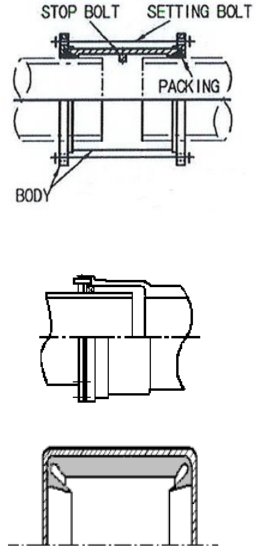
Abbreviations:

- + Application is allowed
- Application is not allowed
- * Fire endurance test as specified in 1.6.11.5.5.6 (P2.11.5.5.6)

Footnotes Table 7 – Fire resistance capability

If mechanical joints include any components which readily deteriorate in case of fire, the following footnotes are to be observed:

1. Fire endurance test shall be applied when mechanical joints are installed in pump rooms and open decks.
2. Slip on joints are not accepted inside machinery spaces of category A or accommodation spaces. May be accepted in other machinery spaces provided the joints are located in easily visible and accessible positions (refer to MSC/Circ.734).
3. Approved fire-resistant types except in cases where such mechanical joints are installed on open decks, as defined in 1.2.51 (SOLAS II-2/Reg. 9.2.2.3.2.2(5) ex SOLAS II-2/Reg. 9.2.3.3.2.2(10)) and not used for fuel oil lines.
4. Fire endurance test shall be applied when mechanical joints are installed inside machinery spaces of category A.

Footnotes Table 7 – General

5. Only above bulkhead deck of passenger ships and freeboard deck of cargo ships.
6. Slip type slip-on joints as shown in Table 6. May be used for pipes on deck with a design pressure of 10 bar or less.
7. If a connection has passed the "30 min dry" test, it is considered suitable also for applications for which the "8 min dry+22 min wet" and/or "30 min wet" tests are required. If a connection has passed the "8 min dry+22 min wet" test, it is considered suitable also for applications for which the "30 min wet" test is required.

Table 8 Application of mechanical joints depending upon the class of piping

Types of joints	Classes of piping systems		
	Class I	Class II	Class III
Pipe Unions			
Welded and brazed type	+ (OD ≤ 60.3 mm)	+ (OD ≤ 60.3 mm)	+
Compression Couplings			
Swage type	+	+	+
Bite type	+ (OD ≤ 60.3 mm)	+ (OD ≤ 60.3 mm)	+
Typical compression type	+ (OD ≤ 60.3 mm)	+ (OD ≤ 60.3 mm)	+
Flared type	+ (OD ≤ 60.3 mm)	+ (OD ≤ 60.3 mm)	+
Press type	-	-	+
Slip-on joints			
Machine grooved type	+	+	+
Grip type	-	+	+

Slip type	-	+	+
-----------	---	---	---

Abbreviations:

- + Application is allowed
- Application is not allowed

1.6.8 Hydrostatic tests of piping (P2.8)

1.6.8.1 All (...) steam, hydraulic, pneumatic and other systems and their associated fittings which are under internal pressure shall be subjected to appropriate tests including a pressure test before being put into service for the first time. (SOLAS Reg. II-1/26.5)

1.6.8.2 All Classes I and II pipes and integral fittings and, in all cases, all steam pipes, feed pipes, compresses air pipes and fuel oil pipes having a design pressure greater than 3,5 bar and relative integral fittings, after completion of manufacture but before insulation and coating, if any, shall be subject to a hydrostatic test in the presence of the Surveyor at the following value of pressure:

$$P_H = 1,5P$$

where P_H = test pressure (bar)

P = design pressure (bar) as defined in 1.5.2.8 (P1.2.7).

For steel pipes and integral fittings for temperatures above 300°C, the test pressure is to be determined by the following formula but it is not necessary that it exceeds $2P$:

$$P_H = 1,5P \frac{K_{100}}{K_T}$$

where K_{100} = permissible stress at 100°C.

K_T = permissible stress at the design temperature.

The value of the test pressure may be reduced, with the approval of the Classification Society, to $1,5P$ in order to avoid excessive stress in way of bends, T-pieces, etc.

In no case is the membrane stress to exceed 90 percent of the yield stress at the testing temperature. (P2.8.1)

1.6.8.3 When, for technical reasons, it is not possible to carry out complete hydrotesting before assembly on board, for all sections of piping, proposals are to be submitted for approval to the Classification Society for testing the closing lengths of piping, particularly in respect to the closing seams. (P2.8.2)

1.6.8.4 When the hydrostatic test of piping is carried out on board, these tests may be carried out in conjunction with the test required under 1.6.9 (P2.9). (P2.8.3)

1.6.8.5 Pressure testing of small bore pipes (less than about 15 mm) may be waived at the discretion of the Classification Society depending on the application. (P2.8.4)

1.6.9 Pressure tests of piping after assembly on board (P2.9)

After assembly on board, the following tightness tests are to be carried out in the presence of the Surveyor.

In general, all the piping systems covered by these requirements are to be checked for leakage under operational conditions and, if necessary, using special techniques other than hydrostatic testing. In particular, heating coils in tanks and liquid or gas fuel lines are to be tested to not less than $1,5P$ but in no case less than 4 bar.

1.6.10 Hydrostatic tests of valves and fittings (P2.10)

Valves and fittings non-integral with the piping system, intended for Classes I and II, are to be tested in accordance with recognized standards, but to not less than 1,5 times the design pressure.

Valves and fittings designed for rated pressures 1 bar or less, as well as for underpressure shall be tested by hydraulic pressure equal to at least 2 bar. Valves shall be tested for closing tightness by hydraulic pressure equal to the design pressure.

While testing the valves and fittings, the requirements specified in generally recognized standards (e.g. PN-W-74017 – Ship's fitting – Requirements and testing, and PN EN 12266-1 – Industrial valves – Testing of valves – Part 1: Pressure tests, test procedures and acceptance criteria. Mandatory requirements) shall be taken into account:

Valves and cocks intended to be fitted on the ship side below the load waterline are to be tested by hydraulic pressure not less than 5 bar.

1.6.11 Type Approval of Mechanical Joints (P2.11)

1.6.11.1 General (P2.11.1)

This specification describes the type testing condition for type approval of mechanical joints intended for use in marine piping systems. Conditions outlined in these requirements are to be fulfilled before Type Approval Certificates are issued.

Individual Societies may specify more severe testing conditions and additional tests if considered necessary to ensure the intended reliability and also accept alternative testing in accordance with national or international standards where applicable to the intended use and application.

1.6.11.2 Scope (P2.11.2)

This specification is applicable to mechanical joints defined in 1.6.7.4 (UR P2.7.4) including compression couplings and slip-on joints of different types for marine use.

1.6.11.3 Documentation (P2.11.3)

Following documents and information are to be submitted by Manufacturer for assessment and/or approval:

- .1 product quality assurance system implemented;
- .2 complete description of the product;
- .3 typical sectional drawings with all dimensions necessary for evaluation of joint design;
- .4 complete specification of materials used for all components of the assembly;
- .5 proposed test procedure as required in 1.6.11.5 (P2.11.5) and corresponding test reports or other previous relevant tests;
- .6 initial information:
 - maximum design pressures (pressure and vacuum);
 - maximum and minimum design temperatures;
 - conveyed media;
 - intended services;
 - maximum axial, lateral and angular deviation, allowed by manufacturer;
 - installation details.

1.6.11.4 Materials (P2.11.4)

The materials used for mechanical joints are to comply with the requirements of 1.6.7.4.3 (P2.7.4.3).

The manufacturer has to submit evidence to substantiate that all components are adequately resistant to working the media at design pressure and temperature specified.

1.6.11.5 Testing, procedures and requirements (P2.11.5)

The aim of tests is to demonstrate ability of the pipe joints to operate satisfactory under intended service conditions. The scope and type of tests to be conducted e.g. applicable tests, sequence of testing, and the number of specimen, is subject to approval and will depend on joint design and its intended service in accordance with the requirements of this UR.

Unless otherwise specified, the water or oil as test fluid is to be used.

1.6.11.5.1 Test program (P2.11.5.1)

Testing requirements for mechanical joints are to be as indicated in Table 9.

1.6.11.5.2 Selection of Test Specimen (P2.11.5.2)

Test specimens are to be selected from production line or at random from stock.

Where there is a variety of size of joints requiring approval, a minimum of three separate sizes, representative of the range, from each type of joint to be tested in accordance with Table 9 are to be selected.

Table 9

Tests		Types of mechanical joint			Notes and references
		Compression couplings and pipe unions	Slip on Joints		
			Grip type & Machine grooved type	Slip type	
1	Tightness test	+	+	+	1.6.11.5.5.1 (P2.11.5.5.1)
2	Vibration (fatigue) test	+	+	-	1.6.11.5.5.2 (P2.11.5.5.2)
3	Pressure pulsation test ¹	+	+	-	1.6.11.5.5.3 (P2.11.5.5.3)
4	Burst pressure test	+	+	+	1.6.11.5.5.4 (P2.11.5.5.4)
5	Pull-out test	+	+	-	1.6.11.5.5.5 (P2.11.5.5.5)
6	Fire endurance test	+	+	+	1.6.11.5.5.6 (P2.11.5.5.6) If required by 1.6.7.4.5 (UR P2.7.4.5)
7	Vacuum test	+ ³	+	+	1.6.11.5.5.7 (P2.11.5.5.7) for suction lines only
8	Repeated assembly test	+ ²	+	-	1.6.11.5.5.8 (P2.11.5.5.8)

Abbreviations:

- + test is required
- test is not required

Footnotes:

- ¹ For use in those systems where pressure pulsation other than water hammer is expected.
- ² Except press type and swage type.
- ³ Except joints with metal-to-metal tightening surfaces.

1.6.11.5.3 Mechanical Joint Assembly (P2.11.5.3)

Assembly of mechanical joints should consist of components selected in accordance with 1.6.11.5.2 (P2.11.5.2) and the pipe sizes appropriate to the design of the joints.

Where pipe material would affect the performance of mechanical joints, the selection of joints for testing is to take the pipe material into consideration.

Where not specified, the length of pipes to be connected by means of the joint to be tested is to be at least five times the pipe diameter. Before assembling the joint, conformity of components to the design requirements, is to be verified. In all cases the assembly of the joint shall be carried out only according to the manufacturer's instructions. No adjustment operations on the joint assembly, other than that specified by the manufacturer, are permitted during the test.

1.6.11.5.4 Test Results Acceptance Criteria (P2.11.5.4)

Where a mechanical joint assembly does not pass all or any part of the tests in Table 9, two assemblies of the same size and type that failed are to be tested and only those tests which the mechanical joint assembly failed in the first instance, are to be repeated. In the event where one of the assemblies fails the second test, that size and type of assembly is to be considered unacceptable.

The methods and results of each test are to be recorded and reproduced as and when required.

1.6.11.5.5 Methods of tests (P2.11.5.5)

.1 Tightness test

In order to ensure correct assembly and tightness of the joints, all mechanical joints are to be subjected to a tightness test, as follows.

- a) The mechanical joint assembly test specimen is to be connected to the pipe or tubing in accordance with the requirements of 1.6.11.5.3 (P2.11.5.3) and the manufacturer's instructions, filled with test fluid and de-aerated.

Mechanical joints assemblies intended for use in rigid connections of pipe lengths, are not to be longitudinally restrained.

The pressure inside the joint assembly is to be slowly increased to 1.5 times the design pressure. This test pressure is to be retained for a minimum period of 5 minutes.

In the event of a drop in pressure or visible leakage, the test (including fire test) is to be repeated for two further specimens.

If during the repeat test one test piece fails, the coupling is regarded as having failed.

An alternative tightness test procedure, such as a pneumatic test, may be accepted.

- b) For compression couplings a static gas pressure test is to be carried out to demonstrate the integrity of the mechanical joints assembly for tightness under the influence of gaseous media. The pressure is to be raised to maximum pressure or 70 bar whichever is less.
- c) Where the tightness test is carried out using gaseous media as permitted in (a) above, then the static pressure test mentioned in (b) above need not be carried out.

.2 Vibration (fatigue) test

In order to establish the capability of the mechanical joint assembly to withstand fatigue, which is likely to occur due to vibrations under service conditions, mechanical joint assemblies are to be subject to the following vibration test.

Conclusions of the vibration tests should show no leakage or damage.

- a) **Testing of compression couplings and pipe unions**

Compression couplings and pipe unions intended for use in rigid pipe connections are to be tested as follows. Rigid connections are joints, connecting pipe length without free angular or axial movement.

Two lengths of pipe are to be connected by means of the joint to be tested. One end of the pipe is to be rigidly fixed while the other end is to be fitted to the vibration rig. The test rig and the joint assembly specimen being tested are to be arranged as shown in Fig.1.

Fig. 1

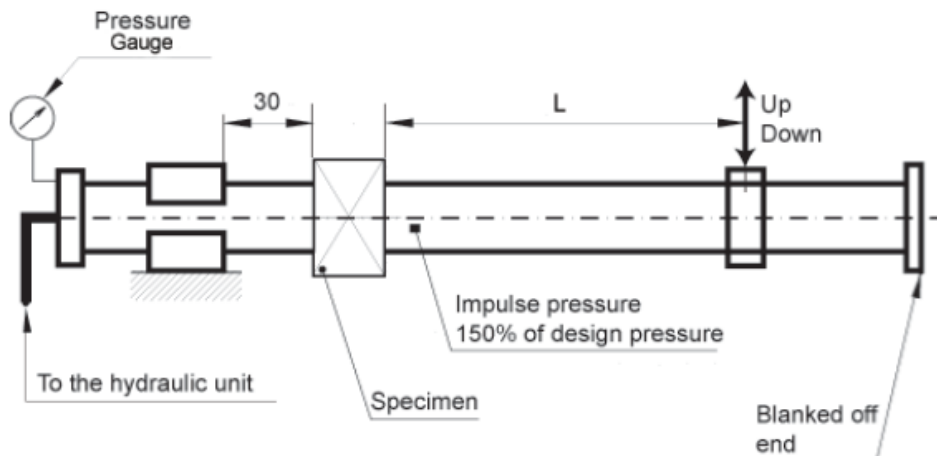

The joint assembly is to be filled with test fluid, de-aerated and pressurised to the design pressure of the joint.

Pressure during the test is to be monitored. In the event of a drop in the pressure and visible leakage the test is to be repeated as described in 1.6.11.5.4 (P2.11.5.4).

Visual examination of the joint assembly is to be carried out.

Re-tightening may be accepted once during the first 1000 cycles.

Vibration amplitude is to be within 5% of the value calculated from the following formula:

$$A = \frac{2SL^2}{3ED}$$

where: A – single amplitude, mm
 L – length of the pipe, mm
 S – allowable bending stress in N/mm² based on 0.25 of the yield stress
 E – modulus of elasticity of tube material (for mild steel, $E = 210 \text{ kN/mm}^2$)
 D – outside diameter of tube, mm.

Test specimen is to withstand not less than 10^7 cycles with frequency 20 - 50 Hz without leakage or damage.

b) Grip type and Machine grooved type joints

Grip type joints and other similar joints containing elastic elements are to be tested in accordance with the following method.

A test rig of cantilever type used for testing fatigue strength of components may be used. The test specimen being tested is to be arranged in the test rig as shown in Fig. 2.

Fig. 2

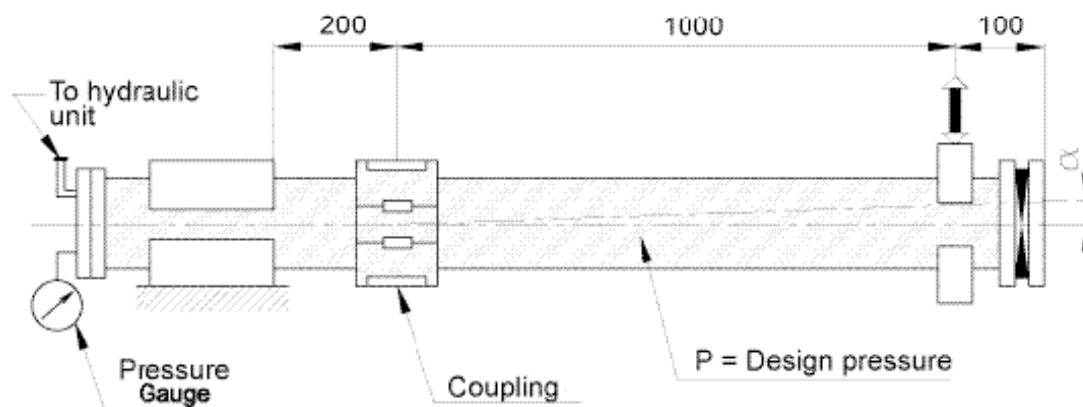

Two lengths of pipes are to be connected by means of joint assembly specimen to be tested. One end of the pipe is to be rigidly fixed while the other end is to be fitted to the vibrating element on the rig. The length of pipe connected to the fixed end should be kept as short as possible and in no case exceed 200 mm.

Mechanical joint assemblies are not to be longitudinally restrained.

The assembly is to be filled with test fluid, de-aerated and pressurized to the design pressure of the joint. Preliminary angle of deflection of pipe axis is to be equal to the maximum angle of deflection, recommended by the manufacturer. The amplitude is to be measured at 1m distance from the center line of the joint assembly at free pipe end connected to the rotating element of the rig. (See Fig. 2)

Parameters of testing are to be as indicated below and to be carried out on the same assembly:

Number of cycles	Amplitude, mm	Frequency, Hz
3·10 ⁶	± 0.06	100
3·10 ⁶	± 0.5	45
3·10 ⁶	± 1.5	10

Pressure during the test is to be monitored. In the event of a drop in the pressure and visual signs of leakage the test is to be repeated as described in 1.6.11.5.4 (P2.11.5.4). Visual examination of the joint assembly is to be carried out for signs of damage which may eventually cause leakage.

.3 Pressure pulsation test

In order to determine capability of mechanical joint assembly to withstand pressure pulsation likely to occur during working conditions, joint assemblies intended for use in rigid connections of pipe lengths, are to be tested in accordance with the following method.

The mechanical joint test specimen for carrying out this test may be the same as that used in the test in 1.6.11.5.5.1 a) (P2.11.5.5.1 (a)) provided it passed that test.

The vibration test in 1.6.11.5.5.2 (P2.11.5.5.2) and the pressure pulsation test are to be carried out simultaneously for compression couplings and pipe unions.

The mechanical joint test specimen is to be connected to a pressure source capable of generating pressure pulses of magnitude as shown in Fig 3.

Fig. 3 Impulse pressure diagram

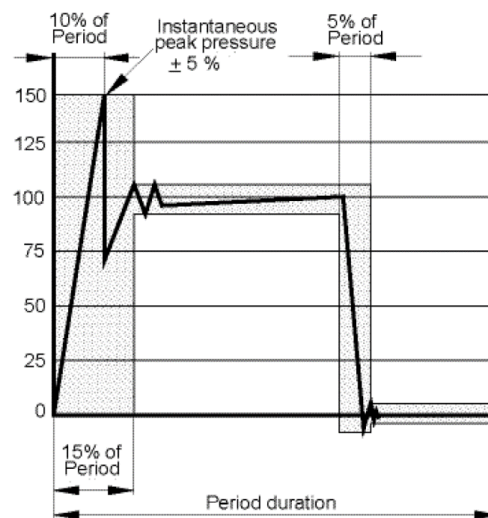

Impulse pressure is to be raised from 0 to 1.5 times the design pressure of the joint with a frequency equal to 30-100 cycles per minute. The number of cycles is not to be less than 5×10^5 .

The mechanical joint is to be examined visually for sign of leakage or damage during the test.

.4 Burst pressure test

In order to determine the capability of the mechanical joint assembly to withstand a pressure as stated by 1.6.7.4.4 (UR P2.7.4.4), the following burst test is to be carried out.

Mechanical joint test specimen is to be connected to the pipe or tubing in accordance with the requirements of 1.6.11.5.3 (P2.11.5.3), filled with test fluid, de-aerated and pressurized to test pressure with an increasing rate of 10% per minute of test pressure. The mechanical joint assembly intended for use in rigid connections of pipe lengths is not to be longitudinally restrained.

Duration of this test is not to be less than 5 minutes at the maximum pressure.

Where considered convenient, the mechanical joint test specimen used in the tightness test in 1.6.11.5.5.1 (P2.11.5.5.1), may be used for the burst test provided it passed the tightness test.

The specimen may exhibit a small deformation whilst under test pressure, but no leakage or visible cracks are permitted.

.5 Pull-out test

In order to determine the ability of a mechanical joint assembly to withstand the axial loading likely to be encountered in service without the connecting pipe becoming detached, following pull-out test is to be carried out.

Pipes of suitable length are to be fitted to each end of the mechanical joint assembly test specimen. The test specimen is to be pressurized to design pressure. When pressure is attained, an external axial load is to be imposed with a value calculated using the following formula:

$$L = \frac{\pi}{4} D^2 p$$

where: D – pipe outside diameter, mm
 p – design pressure, N/mm²
 L – applied axial load, N

The pressure and axial load are to be maintained for a period of 5 minutes.

During the test, pressure is to be monitored and relative movement between the joint assembly and the pipe measured.

The mechanical joint assembly is to be visually examined for drop in pressure and signs of leakage or damage.

There is to be no movement between the mechanical joint assembly and the connecting pipes.

.6 Fire endurance test

In order to establish capability of the mechanical joints to withstand effects of fire which may be encountered in service, mechanical joints are to be subjected to a fire endurance test. The fire endurance test is to be conducted on the selected test specimens as per the following standards.

- (a) ISO 19921:2005: Ships and marine technology – Fire resistance of metallic pipe components with resilient and elastomeric seals – Test methods
- (b) ISO 19922:2005: Ships and marine technology – Fire resistance of metallic pipe components with resilient and elastomeric seals – Requirements imposed on the test bench.

Clarifications to the standard requirements in ISO19921:2005, Paragraphs 7.2, 7.4, 7.6 and 7.7:

- .1 If the fire test is conducted with circulating water at a pressure different from the design pressure of the joint (however of at least 5 bar) the subsequent pressure test is to be carried out to 1.5 times the design pressure.
- .2 If the fire test is required in Table 7 to be “**8 min dry + 22 min wet**” or “**30 min dry**”, i.e. conducted for a period of time without circulating of water, the following test conditions apply:

Test condition “8 min dry + 22 min wet”

The test piece is not required to be rinsed with the test medium (water) in preparation for the test as required in Paragraph 7.2 of ISO 19921:2005. The exposure to fire is to be started and continued for 8 minutes with the sample dry; after 8 minutes of dry test condition the piping system is to be filled with water and test pressure is to be increased up to at least 5 bar within 2 minutes, then maintained to at least 5 bar. After further 22 minutes (i.e. 30 minutes from initial exposure to fire) the exposure to fire is to be stopped and a hydrostatic pressure test as specified in 1. is to be carried out.

Test condition “30 min dry”

The exposure to fire is to be started and continued for 30 minutes with the sample dry. After 30 minutes the exposure to fire is to be stopped and a hydrostatic pressure test as specified in 1. is to be carried out.

Note

For fire tests in dry condition the pressure inside the test specimen is to be monitored for a rise due to heating of the enclosed air. Means of pressure relief should be provided where deemed necessary.

High pressures created during this test can result in failure of the test specimen. Precautions shall be taken to protect personnel and facilities.

Paragraph 7.5 of ISO 19921:2005 does not apply to the dry tests and no forced air circulation is to be arranged.

For fire endurance test requiring exposure time greater than 30 minutes test conditions are adjusted to meet the extended required total exposure time. In all cases for dry-wet test the minimum dry test exposure time is 8 minutes.

- .3 A selection of representative nominal bores may be tested in order to evaluate the fire resistance of a series or range of mechanical joints of the same design. When a mechanical joint of a given nominal bore (D_n) is so tested then other mechanical joints falling in the range D_n to $2xD_n$ (both inclusive) are considered accepted.
- .4 Alternative test methods and/or test procedures considered to be at least equivalent may be accepted at the discretion of the Classification Society in cases where the test pieces are too large for the test bench and cannot be completely enclosed by the flames.
- .5 Where thermal insulation is acceptable as a means of providing fire resistance following requirements apply:
 1. Thermal insulation materials applied on couplings are to be non-combustible according to ISO 1182:2010 as required by the *Fire Test Procedures Code* defined in Regulation 3 of SOLAS Chapter II-2 as amended by IMO resolutions up to MSC.421(98).

Precautions are to be taken to protect the insulation from being impregnated with flammable oils.
 2. At least the fire endurance and the vibration testing in table 9 are to be carried out with thermal insulation in place.
 3. A service restriction is to be stated on the type approval certificate that the mechanical joints are to be fitted with thermal insulation during the installation in cases where the mechanical joints are used where fire resistance is required, unless mechanical joints are delivered already fitted with thermal insulation before installation.

.7 Vacuum test

In order to establish the capability of the mechanical joint assembly to withstand internal pressures below atmospheric, similar to the conditions likely to be encountered under service conditions, the following vacuum test is to be carried out.

The mechanical joint assembly is to be connected to a vacuum pump and subjected to a pressure of 170 mbar absolute. Once this pressure is stabilized, the specimen under test is to be isolated from the vacuum pump and the pressure is to be maintained for a period of 5 minutes.

No internal pressure rise is permitted.

.8 Repeated assembly test

The mechanical joint test specimen is to be dismantled and reassembled 10 times in accordance with manufacturer's instructions and then subjected to a tightness test as defined in P2.11.5.5.1.

1.6.12 Flexible Hoses (P2.12)



1.6.12.1 Definition (P2.12.1)

1.6.12.1.1 Flexible hose assembly – short length of metallic or non-metallic hose normally with prefabricated end fittings ready for installation. (P2.12.1.1)

Note: Flexible hose assemblies for essential services or containing either flammable or toxic media are not to exceed 1.5 m in length.

Note:

“Short length” according to MSC.1/Circ.1321 should not in general exceed 1.5 m.

1.6.12.2 Scope (P2.12.2)

1.6.12.2.1 The requirements 1.6.12.3 to 1.6.12.6 (P2.12.3 to P2.12.6) apply to flexible hoses of metallic or non-metallic material intended for a permanent connection between a fixed piping system and items of machinery. The requirements may also be applied to temporary connected flexible hoses or hoses of portable equipment. (P2.12.2.1)

1.6.12.2.2 Flexible hose assemblies as defined in 1.6.12.1.1 (P2.12.1.1) may be accepted for use in oil fuel, lubricating, hydraulic and thermal oil systems, fresh water and sea water cooling systems, compressed air systems, bilge and ballast systems, and Class III steam systems where they comply with 1.6.12.3 to 1.6.12.6 (P2.12.3 to P2.12.6). Flexible hoses in high pressure fuel oil injection systems are not to be accepted. (P2.12.2.2)

1.6.12.2.3 These requirements for flexible hose assemblies are not applicable to hoses intended to be used in fixed fire extinguishing systems. (P2.12.2.3)

1.6.12.3 Design and construction (P2.12.3)

1.6.12.3.1 Flexible hoses are to be designed and constructed in accordance with recognised National or International standards acceptable to the Classification Society. Flexible hoses constructed of rubber materials and intended for use in bilge, ballast, compressed air, oil fuel, lubricating, hydraulic and thermal oil systems are to incorporate a single, double or more, closely woven integral wire braid or other suitable material reinforcement.

Flexible hoses of plastics materials for the same purposes, such as Teflon or Nylon, which are unable to be reinforced by incorporating closely woven integral wire braid are to have suitable material reinforcement as far as practicable.

Where rubber or plastics materials hoses are to be used in oil supply lines to burners, the hoses are to have external wire braid protection in addition to the reinforcement mentioned above. Flexible hoses for use in steam systems are to be of metallic construction. (P2.12.3.1)

1.6.12.3.2 Flexible hoses are to be complete with approved end fittings in accordance with manufacturer’s specification. The end connections that do not have a flange are to comply with 1.6.7.4 (P2.7.4) as applicable and each type of hose/fitting combination is to be subject to prototype testing to the same standard as that required by the hose with particular reference to pressure and impulse tests. (P2.12.3.2)

1.6.12.3.3 The use of hose clamps and similar types of end attachments is not acceptable for flexible hoses in piping systems for steam, flammable media, starting air systems or for sea water systems where failure may result in flooding. In other piping systems, the use of hose clamps may be accepted where the working pressure is less than 5 bar and provided there are double clamps at each end connection. (P2.12.3.3)

1.6.12.3.4 Flexible hose assemblies intended for installation in piping systems where pressure pulses and/or high levels of vibration are expected to occur in service, are to be designed for the

maximum expected impulse peak pressure and forces due to vibration. The tests required by 1.6.12.5 (P2.12.5) are to take into consideration the maximum anticipated in-service pressures, vibration frequencies and forces due to installation. **(P2.12.3.4)**

1.6.12.3.5 Flexible hose assemblies constructed of non-metallic materials intended for installation in piping systems for flammable media and sea water systems where failure may result in flooding, are to be of fire-resistant type except in cases where such hoses are installed on open decks, as defined in 1.2.51 (SOLAS II-2/Reg. 9.2.2.3.2.2(5) ex Regulation 9.2.3.3.2.2(10) of SOLAS Chapter II-2 as amended by IMO resolutions up to MSC.421(98)) and not used for fuel oil lines. Fire resistance is to be demonstrated by testing to ISO 15540:2016 and ISO 15541:2016. **(P2.12.3.5)**

1.6.12.3.6 Flexible hose assemblies are to be selected for the intended location and application taking into consideration ambient conditions, compatibility with fluids under working pressure and temperature conditions consistent with the manufacturer's instructions and any requirements of the Classification Society. **(P2.12.3.6)**

1.6.12.4 Installation (P2.12.4)

1.6.12.4.1 In general, flexible hoses are to be limited to a length necessary to provide for relative movement between fixed and flexibly mounted items of machinery/equipment or systems. **(P2.12.4.1)**

Flexible hose assemblies shall not be used for other purposes than providing for the relative movement i.e. they shall not replace permanent rigid pipes (neither metal nor plastic).

1.6.12.4.2 Flexible hose assemblies are not to be installed where they may be subjected to torsion deformation (twisting) under normal operating conditions. **(P2.12.4.2)**

1.6.12.4.3 The number of flexible hoses, in piping systems mentioned in 1.6.12.2.2 (P2.12.2.2) is to be kept to minimum and to be limited for the purpose stated in 1.6.12.2.1 (P2.12.2.1). **(P2.12.4.3)**

1.6.12.4.4 Where flexible hoses are intended to be used in piping systems conveying flammable fluids that are in close proximity of heated surfaces the risk of ignition due to failure of the hose assembly and subsequent release of fluids is to be mitigated as far as practicable by the use of screens or other similar protection to the satisfaction of the Classification Society. **(P2.12.4.4)**

1.6.12.4.5 Flexible hoses are to be installed in clearly visible and readily accessible locations. **(P2.12.4.5)**

1.6.12.4.6 The installation of flexible hose assemblies is to be in accordance with the manufacturer's instructions and use limitations with particular attention to the following:

- Orientation
- End connection support (where necessary)
- Avoidance of hose contact that could cause rubbing and abrasion
- Minimum bend radii **(P2.12.4.6)**

1.6.12.5 Tests (P2.12.5)

1.6.12.5.1 Acceptance of flexible hose assemblies is subject to satisfactory prototype testing. Prototype test programmes for flexible hose assemblies are to be submitted by the manufacturer

and are to be sufficiently detailed to demonstrate performance in accordance with the specified standards. **(P2.12.5.1)**

1.6.12.5.2 The tests are, as applicable, to be carried out on different nominal diameters of hose type complete with end fittings for pressure, burst, impulse resistance and fire resistance in accordance with the requirements of the relevant standard. The following standards are to be used as applicable.

- ISO 6802:2018 – Rubber and plastics hoses and hose assemblies with wire reinforcements – Hydraulic impulse test with flexing.
- ISO 6803:2017 – Rubber or plastics hoses and hose assemblies – Hydraulic-pressure impulse test without flexing.
- ISO 15540:2016 – Ships and marine technology - Fire resistance of hose assemblies – Test methods.
- ISO 15541:2016 – Ships and marine technology - Fire resistance of hose assemblies – Requirements for test bench.
- ISO 10380:2012 – Pipework – Corrugated metal hoses and hose assemblies.

Other standards may be accepted where agreed by the classification society. **(P2.12.5.2)**

Note:

Prototype tests are to be carried out for each size of hose assembly. However, for ranges with more than 3 different diameters, the prototype tests are to be carried out for at least:

- the smallest diameter,
- the largest diameter,
- Intermediate diameters selected based on the principle that prototype tests carried out for a hose assembly with a diameter D are considered valid only for the diameters ranging between $0.5 D$ and $2 D$.

For fire resistance tests the specimens shall be selected in accordance with ISO 15540:2016.

1.6.12.5.3 All flexible hose assemblies are to be satisfactorily prototype burst tested to an international standard* to demonstrate they are able to withstand a pressure not less than four times its design pressure without indication of failure or leakage. **(P2.12.5.3)**

Note * The international standards, e.g. EN or SAE for burst testing of non-metallic hoses, require the pressure to be increased until burst without any holding period at $4 \times$ MWP.

1.6.12.6 Marking (P2.12.6)

1.6.12.6.1 Flexible hoses are to be permanently marked by the manufacturer with the following details:

- Hose manufacturer's name or trademark;
- Date of manufacture (month/year);
- Designation type reference;
- Nominal diameter;
- Pressure rating;
- Temperature rating.

Where a flexible hose assembly is made up of items from different manufacturers, the components are to be clearly identified and traceable to evidence of prototype testing. **(P2.12.6.1)**

1.6.13 Installation (P2.13)

1.6.13.1 Protection from Mechanical Damage (P2.13.1)

1.6.13.1.1 Seawater pipes in cargo holds for dry cargoes, including cargo spaces of container ships, ro-ro ships, are to be protected from impact of cargo where they are liable to be damaged. (P2.13.1.1)

END OF IACS UR P2

1.7 Production and application of plastic piping systems on ships*

IACS UR P4

* This UR addresses the provisions of IMO Resolution A.753(18), as amended by IMO Resolutions MSC.313(88) and MSC.399(95).

Note:

(...)

5. The “date of application for type approval” is the date of documents accepted by the Classification Society as request for type approval certification of a new equipment type or of an equipment type that has undergone substantive modifications in respect of the one previously type approved, or for renewal of an expired type approval certificate.

1.7.1 Terms and Conditions (P4.1)

- .1 “**Plastic(s)**” means both thermoplastic and thermosetting plastic materials with or without reinforcement, such as PVC and fibre reinforced plastics - FRP. Plastic includes synthetic rubber and materials of similar thermo/mechanical properties.
- .2 “**Pipes/piping systems**” means those made of plastic(s) and include the pipes, fittings, system joints, method of joining and any internal or external liners, coverings and coatings required to comply with the performance criteria.
- .3 “**Joint**” means the location at which two pieces of pipe or a pipe and a fitting are connected together. The joint may be made by adhesive bonding, laminating, welding, flanges etc.
- .4 “**Fittings**” means bends, elbows, fabricated branch pieces etc. of plastic materials.
- .5 “**Nominal pressure**” means the maximum permissible working pressure which should be determined in accordance with the requirements in 1.7.3.1 (P4.3.1).
- .6 “**Design pressure**” means the maximum working pressure which is expected under operation conditions or the highest set pressure of any safety valve or pressure relief device on the system, if fitted.
- .7 “**Fire endurance**” means the capability of piping to maintain its strength and integrity (i.e. capable of performing its intended function) for some predetermined period of time while exposed to fire.

1.7.2 Scope (P4.2)

- .1 These requirements are applicable to piping systems on ships, including pipe joints and fittings, made predominately of other material than metal.
- .2 Use of mechanical and flexible couplings which are accepted for use in metallic piping systems is not addressed.
- .3 Piping systems intended for non-essential services are to meet only the requirements of recognized standards and 1.7.3.1.3 (i), 1.7.4.2, 1.7.5.2 to 1.7.5.7 and 1.7.6 (P4.3.1.3 (ii), P4.4.2, P4.5.2 to P4.5.7 and P4.6 of this UR).

1.7.3 General Requirements (P4.3)



The specification of piping is to be in accordance with a recognised national or international standard acceptable to the Classification Society. In addition, the following requirements apply:

1.7.3.1 Strength (4.3.1)

- .1 The strength of the pipes is to be determined by a hydrostatic test failure pressure of a pipe specimen under the standard conditions: atmospheric pressure equal to 100 kPa, relative humidity 30%, environmental and carried fluid temperature 298 kPa (25°C).
- .2 The strength of fittings and joints is to be not less than that of the pipes.
- .3 The nominal pressure is to be determined from the following conditions:

(i) Internal Pressure

For an internal pressure the following is to be taken whichever is smaller:

$$P_{n\text{ int}} \leq P_{\text{sth}}/4 \text{ or } P_{n\text{ int}} \leq P_{\text{lth}}/2.5$$

where P_{sth} = short-term hydrostatic test pipe failure pressure;

P_{lth} = long-term hydrostatic test pipe failure pressure (> 100,000 h)

- ##### (ii) External Pressure (for any installation which may be subject to vacuum conditions inside the pipe or a head of liquid acting on the outside of the pipe; and for any pipe installation required to remain operational in case of flooding damage, as per Regulation 8-1 of SOLAS Chapter II-1, as amended by IMO Resolutions up to MSC.436(99), or for any pipes that would allow progressive flooding to other compartments through damaged piping or through open ended pipes in the compartments).

For an external pressure:

$$P_{n\text{ ext}} \leq P_{\text{col}}/3$$

where P_{col} – pipe collapse pressure.

In no case is the pipe collapse pressure to be less than 3 bar.

- ##### (iii) The collapse pressures are to be determined by experimental method, and in case of long-term hydrostatic test, in order to while away the time of its duration, it is possible to use combination of experimental and calculation method (e.g. according to ASTM D2837 or ASTM D1598 standard).

The maximum working external pressure is a sum of the vacuum inside the pipe and a head of liquid acting on the outside of the pipe.

- .4 Notwithstanding the requirements of 3(i) or 3(ii) above as applicable, the pipe or pipe layer minimum wall thickness is to follow recognized standards. In the absence of standards for pipes not subject to external pressure, the requirements of 3(ii) above are to be met.
- .5 The maximum permissible working pressure is to be specified with due regard for maximum possible working temperatures in accordance with Manufacturer's recommendations.

1.7.3.2 Axial Strength (4.3.2)

- .1 The sum of the longitudinal stresses due to pressure, weight and other loads is not to exceed the allowable stress in the longitudinal direction.

- .2 In the case of fibre reinforced plastic pipes, the sum of the longitudinal stresses is not to exceed half of the nominal circumferential stress derived from the nominal internal pressure condition (see 1.7.3.1 (P4.3.1)).

1.7.3.3 Impact Resistance (4.3.3)

- .1 Plastic pipes and joints are to have a minimum resistance to impact in accordance with recognized national or international standards.
- .2 After the test the specimen is to be subjected to hydrostatic pressure equal to 2.5 times the design pressure for at least 1 hour.

1.7.3.4 Temperature (4.3.4)

- .1 The permissible working temperature depending on the working pressure is to be in accordance with Manufacturer's recommendations, but in each case it is to be at least 20°C lower than the minimum heat distortion/deflection temperature of the pipe material, determined according to ISO 75-2:2013 method A, or equivalent e.g. ASTM D648-18.
- .2 The minimum heat distortion/deflection temperature is to be not less than 80°C.

1.7.4 Requirements for Pipes/Piping Systems Depending on Service and/or Locations (P4.4)

1.7.4.1 Fire endurance (4.4.1)

- .1 Pipes and their associated fittings whose integrity is essential to the safety of ships, including plastic piping required by Regulation 21.4 of SOLAS Chapter II-2 as amended by IMO Resolutions up to 421(98) (hereinafter the same) to remain operational after a fire casualty, are required to meet the minimum fire endurance requirements of Appendix 1 or 2, as applicable, of IMO Resolution A.753(18), as amended by IMO Resolutions MSC.313(88) and MSC.399(95).
- .2 Depending on the capability of a piping system to maintain its strength and integrity, there exist three different levels of fire endurance for piping systems.
 - (i) **Level 1.** Piping having passed the fire endurance test specified in Appendix 1 of IMO Resolution A.753(18), as amended by IMO Resolutions MSC.313(88) and MSC.399(95) for a duration of a minimum of one hour without loss of integrity in the dry condition is considered to meet level 1 fire endurance standard (**L1**). **Level 1W** – Piping systems similar to Level 1 systems except these systems do not carry flammable fluid or any gas and a maximum 5% flow loss in the system after exposure is acceptable (**L1W**).
 - (ii) **Level 2.** Piping having passed the fire endurance test specified in Appendix 1 of IMO Resolution A.753(18), as amended by IMO Resolutions MSC.313(88) and MSC.399(95) for a duration of a minimum of 30 minutes in the dry condition is considered to meet level 2 fire endurance standard (**L2**). **Level 2W** – Piping systems similar to Level 2 systems except a maximum 5% flow loss in the system after exposure is acceptable (**L2W**).
 - (iii) **Level 3.** Piping having passed the fire endurance test specified in Appendix 2 of IMO Resolution A.753(18), as amended by IMO Resolutions MSC.313(88) and MSC.399(95) for a duration of a minimum of 30 minutes in the wet condition is considered to meet level 3 fire endurance standard (**L3**).
- .3 Permitted use of piping depending on fire endurance, location and piping system is given in Table 1 "Fire Endurance Requirement Matrix".

Note:

Requirements given in Table 1 concerning piping fire endurance are to be considered as a minimum, i.e. piping having higher fire endurance level can be always used instead of pipelines having lower fire endurance level. L1 is the highest fire endurance level while L3 is the lowest level.

- .4** For Safe Return to Port purposes (Regulation 21.4 of SOLAS Chapter II-2 – see *Publication 90/P – Safe return to port and orderly evacuation and abandonment of the ship*), plastic piping can be considered to remain operational after a fire casualty if the plastic pipes and fittings have been tested to L1 standard.

Table 1 Fire Endurance Requirements Matrix

No	Piping Systems	Location ¹³										
		A	B	C	D	E	F	G	H	I	J	K
		Machinery spaces of category A	Other machinery spaces & pump rooms	Cargo pump rooms	Ro/Ro cargo holds	Other dry cargo holds	Cargo tanks	Fuel oil tanks	Ballast water tanks	Cofferdams, void spaces, pipe tunnel & ducts	Accommodation, service & control spaces	Open decks
1	2	3	4	5	6	7	8	9	10	11	12	13
CARGO (FLAMMABLE CARGOES (f.p. ≤ 60°C))												
1.	Cargo lines	NA	NA	L1	NA	NA	0	NA	0 ¹⁰	0	NA	L1 ²
2.	Crude Oil washing lines	NA	NA	L1	NA	NA	0	NA	0 ¹⁰	0	NA	L1 ²
3.	Vent lines	NA	NA	NA	NA	NA	0	NA	0 ¹⁰	0	NA	X
INERT GAS												
4.	Water seal effluent line	NA	NA	0 ¹	NA	NA	0 ¹	0 ¹	0 ¹	0 ¹	NA	0
5.	Scrubber effluent line	0 ¹	0 ¹	NA	NA	NA	NA	NA	0 ¹	0 ¹	NA	0
6.	Main line	0	0	L1	NA	NA	NA	NA	NA	0	NA	L1 ⁶
7.	Distribution lines	NA	NA	L1	NA	NA	0	NA	NA	0	NA	L1 ²
FLAMMABLE LIQUIDS (f.p. > 60°C)												
8.	Cargo lines	X	X	L1	X	X	NA ³	0	0 ¹⁰	0	NA	L1
9.	Fuel oil	X	X	L1	X	X	NA ³	0	0	0	L1	L1
10.	Lubricating	X	X	L1	X	X	NA	NA	NA	0	L1	L1
11.	Hydraulic oil	X	X	L1	X	X	0	0	0	0	L1	L1
SEAWATER												
12.	Bilge main & branches	L1 ⁷	L1 ⁷	L1	X	X	NA	0	0	0	NA	L1
13.	Fire main & Water spray	L1	L1	L1	X	NA	NA	NA	0	0	X	L1
14.	Foam system	L1W	L1W	L1W	NA	NA	NA	NA	NA	0	L1W	L1W
15.	Sprinkler system	L1W	L1W	L3	X	NA	NA	NA	0	0	L3	L3
16.	Ballast	L3	L3	L3	L3	X	0 ¹⁰	0	0	0	L2W	L2W
17.	Cooling water essential services	L3	L3	NA	NA	NA	NA	NA	0	0	NA	L2W
18.	Tank cleaning services fixed machines	NA	NA	L3	NA	NA	0	NA	0	0	NA	L3 ²

19.	Non-essential systems	0	0	0	0	0	NA	0	0	0	0	
FRESHWATER												
20.	Cooling water essential services	L3	L3	NA	NA	NA	NA	0	0	0	L3	L3
21.	Condensate return	L3	L3	L3	0	0	NA	NA	NA	0	0	0
22.	Non-essential systems	0	0	0	0	0	NA	0	0	0	0	0
SANITARY/DRAINS/SCUPPERS												
23.	Deck drains (internal)	L1W ⁴	L1W ⁴	NA	L1W ⁴	0	NA	0	0	0	0	0
24.	Sanitary drains (internal)	0	0	NA	0	0	NA	0	0	0	0	0
25.	Scuppers and discharges (overboard)	0 ^{1,8}	0 ^{1,8}	0 ^{1,8}	0 ^{1,8}	0 ^{1,8}	0	0	0	0	0 ^{1,8}	0
SOUNDING/AIR												
26.	Water tanks/dry spaces	0	0	0	0	0	0 ¹⁰	0	0	0	0	0
27.	Oil tanks (f.p.>60°C)	X	X	X	X	X	X ³	0	0 ¹⁰	0	X	X
MISCELLANEOUS												
28.	Control air	L1 ⁵	L1 ⁵	L1 ⁵	L1 ⁵	L1 ⁵	NA	0	0	0	L1 ⁵	L1 ⁵
29.	Service air (non-essential)	0	0	0	0	0	NA	0	0	0	0	0
30.	Brine	0	0	NA	0	0	NA	NA	NA	0	0	0
31.	Auxiliary low pressure steam (≤ 7 bar)	L2W	L2W	0 ⁹	0 ⁹	0 ⁹	0	0	0	0	0 ⁹	0 ⁹
32.	Central vacuum Cleaners	NA	NA	NA	0	NA	NA	NA	NA	0	0	0
33.	Exhaust Gas Cleaning System Effluent Line	L3 ¹	L3 ¹	NA	NA	NA	NA	NA	NA	NA	L3 ^{1,11} NA	NA
34.	Urea Transfer/Supply System (SCR installations)	L1 ¹²	L1 ¹²	NA	NA	NA	NA	NA	NA	0	L3 ¹¹ NA	0

ABBREVIATIONS:

- L1** Fire endurance test (appendix 1 of IMO Resolution A.753(18), as amended by IMO Resolutions MSC.313(88) and MSC.399(95)) in dry conditions, 60 min
- L1W** Fire endurance test (section 1.7.4.1.2 (P.4.4.1.2))
- L2** Fire endurance test (appendix 1 of IMO Resolution A.753(18), as amended by IMO Resolutions MSC.313(88) and MSC.399(95)) in dry conditions, 30 min
- L2W** Fire endurance test (section 1.7.4.1.2 (P.4.4.1.2))
- L3** Fire endurance test (appendix 2 of IMO Resolution A.753(18), as amended by IMO Resolutions MSC.313(88) and MSC.399(95)) in wet conditions, 30 min

0	No fire endurance test required
NA	Not applicable
X	Metallic materials having a melting point greater than 925°C

FOOTNOTES:

1. Where non-metallic piping is used, remotely controlled valves to be provided at ship's side (valve is to be controlled from outside space).
2. Remote closing valves to be provided at the cargo tanks.
3. When cargo tanks contain flammable tanks with f.p. > 60°C, "0" may replace "NA" or "X".
4. For drains serving only the space concerned, "0" may replace "L1 W".
5. When controlling functions are not required by statutory requirements or guidelines, "0" may replace "L1".
6. For pipe between machinery space and deck water seal, "0" may replace "L1".
7. For passenger vessels, "X" is to replace "L1".
8. Scuppers serving open decks in positions 1 and 2, as defined in *Part III, 7.1.4* (Regulation 13 of *Protocol of 1988* relating to the *International Convention on Load Lines, 1966*, as amended by IMO Resolutions up to MSC.375(93)), should be "X" throughout unless fitted at the upper end with the means of closing capable of being operated from a position above the freeboard deck in order to prevent downflooding.

Note:

For requirements of the *Protocol of 1988* relating to the *International Convention on Load Lines* applicable to scuppers – see 2.2.2 to 2.2.12.

9. For essential services, such as fuel oil tank heating and ships whistle, "X" is to replace "0".
10. For tankers where compliance with paragraph 17.6.2.5 (3.6 of Regulation 19 of MARPOL Annex I, as amended by IMO Resolutions up to MEPC.314(74)) is required, "NA" is to replace "0".
11. "L3" in service spaces, "NA" in accommodation and control spaces.
12. Type Approved plastic piping without fire endurance test (0) is acceptable downstream of the tank valve, provided this valve is metal seated and arranged as fail-to-closed or with quick closing from a safe position outside the space in the event of fire.
13. For Passenger Ships subject to Regulation 21.4 of SOLAS Chapter II-2, (Safe return to Port – see *Publication 90/P – Safe return to port and orderly evacuation and abandonment of the ship*), plastic pipes for services required to remain operative in the part of the ship not affected by the casualty thresholds, such as systems intended to support safe areas, are to be considered essential services. In accordance with MSC.1/Circ.1369, interpretation 12, for Safe Return to Port purposes, plastic piping can be considered to remain operational after a fire casualty if the plastic pipes and fittings have been tested to "L1" standard.

LOCATION DEFINITIONS:

Location	Definition
A - Machinery spaces of category A	Machinery spaces of category A as defined in 1.2.39 (Regulation 3.31 of SOLAS Chapter II-2*).
B - Other machinery spaces and pump rooms	Spaces, other than category A machinery spaces and cargo pump rooms, containing propulsion machinery, boilers, fuel oil units, steam and internal combustion engines, generators and major electrical machinery, oil filling stations, refrigerating, stabilizing, ventilation and air-conditioning machinery, and similar spaces and trunks to such spaces.
C - Cargo pump rooms	Spaces containing cargo pumps and entrances and trunks to such spaces.
D - Ro-ro cargo holds	Ro-ro cargo holds are ro-ro cargo spaces and special category spaces as defined in 1.2.55 and 1.2.62 (Regulations 3.41 and 3.46 of SOLAS Chapter II-2*).
E - Other dry cargo holds	All spaces other than ro-ro cargo holds used for non-liquid cargo and trunks to such spaces.

F - Cargo tanks	All spaces used for liquid cargo and trunks to such spaces.
G - Fuel oil tanks	All spaces used for fuel oil (excluding cargo tanks) and trunks to such spaces.
H - Ballast water tanks	All spaces used for ballast water and trunks to such spaces.
I - Cofferdams, voids, etc.	Cofferdams and voids are those empty spaces between two bulkheads separating two adjacent compartments.
J - Accommodation, service,	Accommodation spaces, service spaces and control stations as defined in 1.2.1, 1.2.59 and 1.2.20 (Regulations 3.1, 3.45 and 3.18 of SOLAS Chapter II-2*).
K - Open decks	Open deck spaces as defined in 1.2.51 (Regulation 9.2.2.3.2(5) of SOLAS Chapter II-2*).

* SOLAS Chapter II-2, as amended by IMO Resolutions up to MSC.421(98)

1.7.4.2 Flame Spread (4.4.2)

- .1 All pipes, except those fitted on open decks and within tanks, cofferdams, pipe tunnels, and ducts if separated from accommodation, permanent manned areas and escape ways by means of an A class bulkhead are to have low surface flame spread characteristics not exceeding average values listed in Appendix 3 of IMO Resolution A.753(18), as amended by IMO Resolutions MSC.313(88) and MSC.399(95).
- .2 Surface flame spread characteristics are to be determined using the procedure given in the *2010 FTP Code*, Annex 1, Part 5 with regard to the modifications due to the curvilinear pipe surfaces as also listed in Appendix 3 of IMO Resolution A.753(18), as amended by IMO Resolutions MSC.313(88) and MSC.399(95).
- .3 Surface flame spread characteristics may also be determined using the test procedures given in ASTM D635-18, or in other national equivalent standards. Under the procedure of ASTM D635-18 a maximum burning rate of 60 mm/min applies. In case of adoption of other national equivalent standards, the relevant acceptance criteria are to be defined.

1.7.4.3 Fire Protection Coatings (4.4.3)

- .1 Where a fire protective coating of pipes and fittings is necessary for achieving the fire endurance level required, it is to meet the following requirements:
 - (i) The pipes are generally to be delivered from the manufacturer with the protective coating on.
 - (ii) The fire protection properties of the coating are not to be diminished when exposed to salt water, oil or bilge slops. It is to be demonstrated that the coating is resistant to products likely to come into contact with the piping.
 - (iii) In considering fire protection coatings, such characteristics as thermal expansion, resistance against vibrations, and elasticity are to be taken into account.
 - (iv) The fire protection coatings are to have sufficient resistance to impact to retain their integrity.

1.7.4.4 Electrical Conductivity (4.4.4)

Where electrical conductivity is to be ensured, the resistance of the pipes and fittings is not to exceed 1×10^5 Ohm/m.

1.7.5 Material approval and Quality Control During Manufacture (P4.5)

- .1 Except as required in 1.7.2.3 (P4.2.3), prototypes of pipes and fittings are to be tested to determine short-term and long-term design strength, fire endurance and low surface flame spread characteristics (if applicable), electrical resistance (for electrically conductive pipes), impact resistance in accordance with this UR.
- .2 For prototype testing representative samples of pipes and fittings are to be selected to the satisfaction of the Classification Society.
- .3 The Manufacturer is to have quality system that meets ISO 9001:2015 or equivalent. The quality system is to consist of elements necessary to ensure that pipes and fittings are produced with consistent and uniform mechanical and physical properties.
- .4 Each pipe and fitting is to be tested by the Manufacturer at a hydrostatic pressure not less than 1.5 times the nominal pressure. Alternatively, for pipes and fittings not employing hand lay up techniques, the hydrostatic pressure test may be carried out in accordance with the hydrostatic testing requirements stipulated in the recognised national or international standard to which the pipe or fittings are manufactured, provided that there is an effective quality system in place.
- .5 Piping and fittings are to be permanently marked with identification. Identification is to include pressure ratings, the design standards that the pipe or fitting is manufactured in accordance with, and the material of which the pipe or fitting is made.
- .6 In case the Manufacturer does not have an approved quality system complying with ISO 9001:2015 or equivalent, pipes and fittings are to be tested in accordance with this UR to the satisfaction of the Classification Society's surveyors for every batch of pipes.
- .7 Depending upon the intended application a Society may require the pressure testing of each pipe and/or fitting.

1.7.6 Installation (P4.6)

1.7.6.1 Supports (4.6.1)

- .1 Selection and spacing of pipe supports in shipboard systems are to be determined as a function of allowable stresses and maximum deflection criteria. Support spacing is not to be greater than the pipe Manufacturer's recommended spacing. The selection and spacing of pipe supports are to take into account pipe dimensions, length of the piping, mechanical and physical properties of the pipe material, mass of pipe and contained fluid, external pressure, operating temperature, thermal expansion effects, loads due to external forces, thrust forces, water hammer, vibrations, maximum accelerations to which the system may be subjected. Combination of loads is to be considered.
- .2 Each support is to evenly distribute the load of the pipe and its contents over the full width of the support. Measures are to be taken to minimize wear of the pipes where they contact the supports.
- .3 Heavy components in the piping system such as valves and expansion joints are to be independently supported.

1.7.6.2 Expansion (4.6.2)

- .1 Suitable provision is to be made in each pipeline to allow for relative movement between pipes made of plastic and the steel structure, having due regard to:
 - (i) the difference in the coefficients of thermal expansion;
 - (ii) deformations of the ship's hull and its structure.
- .2 When calculating the thermal expansions, account is to be taken of the system working temperature and the temperature at which assembly is performed.

1.7.6.3 External Loads (4.6.3)

- .1 When installing the piping, allowance is to be made for temporary point loads, where applicable. Such allowances are to include at least the force exerted by a load (person) of 100 kg at mid-span on any pipe of more than 100 mm nominal outside diameter.
- .2 Besides for providing adequate robustness for all piping including open-ended piping a minimum wall thickness, complying with 1.7.3.1 (4.3.1), may be increased taking into account the conditions encountered during service on board ships.
- .3 Pipes are to be protected from mechanical damage where necessary.

1.7.6.4 Strength of Connections (4.6.4)

- .1 The strength of connections is to be not less than that of the piping system in which they are installed.
- .2 Pipes may be assembled using adhesive-bonded, welded, flanged or other joints.
- .3 Adhesives, when used for joint assembly, are to be suitable for providing a permanent seal between the pipes and fittings throughout the temperature and pressure range of the intended application.
- .4 Tightening of joints is to be performed in accordance with Manufacturer's instructions.

1.7.6.5 Installation of Conductive Pipes (4.6.5)

- .1 In piping systems for fluids with conductivity less than 1000 pico siemens per metre (pS/m) such as refined products and distillates use is to be made of conductive pipes.
- .2 Regardless of the fluid being conveyed, plastic piping is to be electrically conductive if the piping passes through a hazardous area. The resistance to earth from any point in the piping system is not to exceed 1×10^6 Ohm. It is preferred that pipes and fittings be homogeneously conductive. Pipes and fittings having conductive layers are to be protected against a possibility of spark damage to the pipe wall. Satisfactory earthing is to be provided.
- .3 After completion of the installation, the resistance to earth is to be verified. Earthing wires are to be accessible for inspection.

1.7.6.6 Application of Fire Protection Coatings (4.6.6)

- .1 Fire protection coatings are to be applied on the joints, where necessary for meeting the required fire endurance as for 1.7.4.3 (4.4.3), after performing hydrostatic pressure tests of the piping system.
- .2 The fire protection coatings are to be applied in accordance with Manufacturer's recommendations, using a procedure approved in each particular case.

1.7.6.7 Penetration of Divisions (4.6.7)

- .1 Where plastic pipes pass through “A” or “B” class divisions, arrangements are to be made to ensure that the fire endurance is not impaired. These arrangements are to be tested in accordance with Recommendations for fire test procedures for “A”, “B” and “F” bulkheads specified in Part 3 of Annex 1 to the *2010 FTP Code* (Resolution MSC.307(88) as amended by Resolution MSC.437(99)).
- .2 When plastic pipes pass through watertight bulkheads or decks, the watertight integrity of the bulkhead or deck is to be maintained. For pipes not able to satisfy the requirements in 1.7.3.1.3 (ii) (P4.3.1.3 (ii)), a metallic shut-off valve operable from above the freeboard deck should be fitted at the bulkhead or deck.
- .3 If the bulkhead or deck is also a fire division and destruction by fire of plastic pipes may cause the inflow of liquid from tanks, a metallic shut-off valve operable from above the freeboard deck should be fitted at the bulkhead or deck.

1.7.6.8 Control During Installation (4.6.8)

- .1 Installation is to be in accordance with the Manufacturer’s guidelines.
- .2 Prior to commencing the work, joining techniques are to be approved by the Classification Society.
- .3 The tests and explanations specified in this UR are to be completed before shipboard piping installation commences.
- .4 The personnel performing this work are to be properly qualified and certified to the satisfaction of the Classification Society.
- .5 The procedure of making bonds is to include:
 - (i) materials used,
 - (ii) tools and fixtures,
 - (iii) joint preparation requirements,
 - (iv) cure temperature,
 - (v) dimensional requirements and tolerances, and
 - (vi) tests acceptance criteria upon completion of the assembly.
- .6 Any change in the bonding procedure which will affect the physical and mechanical properties of the joint is to require the procedure to be requalified.

1.7.6.9 Bonding Procedure Quality Testing (4.6.9)

- .1 A test assembly is to be fabricated in accordance with the procedure to be qualified and it is to consist of at least one pipe-to-pipe joint and one pipe-to-fitting joint.
- .2 When the test assembly has been cured, it is to be subjected to a hydrostatic test pressure at a safety factor 2.5 times the design pressure of the test assembly, for not less than one hour. No leakage or separation of joints is allowed. The test is to be conducted so that the joint is loaded in both longitudinal and circumferential directions.
- .3 Selection of the pipes used for test assembly, is to be in accordance with the following:
 - (i) When the largest size to be joined is 200 mm nominal outside diameter, or smaller, the test assembly is to be the largest piping size to be joined.

(ii) When the largest size to be joined is greater than 200 mm nominal outside diameter, the size of the test assembly is to be either 200 mm or 25% of the largest piping size to be joined, whichever is greater.

.4 When conducting performance qualifications, each bonder and each bonding operator are to make up test assemblies, the size and number of which are to be as required above.

1.7.6.10 Testing After Installation on Board (4.6.10)

.1 Piping systems for essential services are to be subjected to a test pressure not less than 1.5 times the design pressure or 4 bar whichever is greater.

.2 Piping systems for non-essential services are to be checked for leakage under operational conditions.

.3 For piping required to be electrically conductive, earthing is to be checked, and random resistance testing is to be conducted.

1.7.7 Test Specification For Plastic Pipes (P4.7)

1.7.7.1 Scope (4.7.1)

Section 1.7.7 (P4.7) contains requirements for the Type Approval of plastic pipes. It is applicable to piping systems, including pipe joints and fittings, made predominately of other material than metal.

1.7.7.2 Documentation (4.7.2)

The following information for the plastic pipes, fittings and joints is to be submitted for consideration and approval:

I. General Information

1. Pipe and fitting dimensions
2. Maximum internal and external working pressure
3. Working temperature range
4. Intended services and installation locations
5. The level of fire endurance
6. Electrically conductive
7. Intended fluids
8. Limits on flow rates
9. Serviceable life
10. Installation instructions
11. Details of marking

II. Drawings and supporting documentation:

1. Certificates and reports for relevant tests previously carried out.
2. Details of relevant standards.
3. All relevant design drawings, catalogues, data sheets, calculations and functional descriptions.
4. Fully detailed sectional assembly drawings showing pipe, fittings and pipe connections.

III. Materials (as applicable)

1. The resin type.
2. Catalyst and accelerator types, and concentration employed in the case of reinforced polyester resin pipes or hardeners where epoxide resins are employed.
3. A statement of all reinforcements employed where the reference number does not identify the mass per unit area or the TEX number of a roving used in a filament winding process, these are to be detailed.
4. Full information regarding the type of gel-coat or thermoplastic liner employed during construction, as appropriate.
5. Cure/post-cure conditions. The cure and post cure temperatures and times employ resin/reinforcement ratio.
6. Winding angle and orientation.
7. Joint bonding procedures and qualification tests results, see 1.7.6.8.5 (4.6.8.5).

1.7.7.3 Testing (4.7.3)

Testing is to demonstrate compliance of the pipes, fittings and joints for which Type Approval is sought with 1.7 (Unified Requirement P4).

Pipes, joints and fittings are to be tested for compliance with the requirements of standards* acceptable to classification society.

* For the lists of standards refer to 1.7.8 (IACS Recommendation No. 86).

END OF IACS UR P4

1.7.8 Applicable Standards for 1.7.7 (UR P4.7 “Requirements for Type Approval of Plastic Pipes”)

IACS REC. 86

Table 1: Typical requirements for all systems

	Test	Typical Standard	Notes
1	Internal pressure ⁽¹⁾	1.7.3.1.3 (i) (P4.3.1.3(i)), ASTM D1599, ASTM D2992, ISO 15493 or equivalent	Top, Middle, Bottom (of range) Tests are to be carried out on pipe spools made of different pipe sizes, fittings and pipe connections.
2	External pressure ⁽¹⁾	1.7.3.1.3 (ii) (P4.3.1.3(ii)), ISO 15493 or equivalent	As above, for straight pipes only.
3	Axial strength	1.7.3.2 (P4.3.2)	As above
4	Load deformation	ASTM D2412 or equivalent	Top, Middle, Bottom (of each pressure range)
5	Temperature limitations	ISO 75 Method A GRP piping system: HDT test on each type of resin acc. to ISO 75 method A Thermoplastic piping systems: ISO 75 Method A ISO 306 Plastics - Thermoplastic materials - Determination of Vicat softening temperature (VST) VICAT test according to ISO 2507	Each type of resin

		Polyesters with an HDT below 80°C should not be used.	
6	Impact resistance	ISO 9854, ISO 9653, ISO 15493 ASTM D2444, or equivalent	Representative sample of each type of construction
7	Ageing	Manufacturer's standard ISO 9142	Each type of construction
8	Fatigue	Manufacturer's standard or service experience.	Each type of construction
9	Fluid absorption	ISO 8361	
10	Material compatibility ⁽²⁾	ASTM C581 Manufacturer 's standard	

Table 2: Typical additional requirements depending on service and/or locations of piping

	Test	Typical Standard	Notes
1	Fire endurance ⁽¹⁾⁽²⁾	IMO Res. A.753(18), as amended, Appendix 1, 2	Representative samples of each type of construction and type of pipe connection
2	Flame spread ⁽¹⁾⁽²⁾	IMO Res. A.753(18), as amended, Appendix 3	Representative samples of each type of construction.
3	Smoke generation ⁽²⁾	IMO Res. A.753(18), as amended, Appendix 3	Representative samples of each type of construction.
4	Toxicity ⁽²⁾	IMO Res. A.753(18), as amended, Appendix 3	Representative samples of each type of construction.
5	Electrical conductivity ⁽¹⁾⁽²⁾	ASTM F1173-95 or ASTM D257, NS 6126 para. 11.2 or equivalent	Representative samples of each type of construction

Footnotes:

⁽¹⁾ Test to be witnessed by a Classification Society's Surveyor.

⁽²⁾ If applicable.

Note: Tests of Table 2 are optional however, if not carried out, the range of approved applications for the pipes will be limited accordingly (see 1.7.4 (UR P4.4)).

END OF IACS REC. 86

1.8 Openings and penetrations in watertight structures

1.8.1 General provisions

1.8.1.1 Where the pipes or ventilation ducts pierce watertight bulkheads, decks or other watertight structures, provision shall be made for penetration pieces or other arrangements ensuring the watertight integrity of the structure concerned.

For the penetration of plastic pipes through watertight bulkhead and decks – see 1.7.6.7

1.8.1.2 Valves and fittings installed on watertight bulkheads shall be secured by studs screwed into pads fitted to the bulkhead, or they may be attached to bulkhead penetration pieces.

The stud holes shall not be through holes.

1.8.1.3 Gaskets made of material easily destructible by fire shall not be used.

1.8.1.4 Penetration pieces attached by welding to watertight decks and bulkheads shall be thicker by 1.5 to 3 mm than the wall thickness of a pipe to be connected, depending on its diameter.

1.8.2 Openings and penetrations in collision bulkhead

1.8.2.1 No (...) ventilation ducts or any other openings shall be fitted in the collision bulkhead below the bulkhead deck of passenger ships and the freeboard deck of cargo ships. (SOLAS Reg. II-1/12.5)

1.8.2.2 (...) except as provided in 1.8.2.3 (paragraph 6.3), the collision bulkhead may be pierced below the bulkhead deck of passenger ships and the freeboard deck of cargo ships by not more than one pipe for dealing with fluid in the forepeak tank, provided that the pipe is fitted with a remotely controlled valve capable of being operated from above the bulkhead deck of passenger ships and the freeboard deck of cargo ships. The valve shall be normally closed. If the remote control system should fail during operation of the valve, the valve shall close automatically or be capable of being closed manually from a position above the bulkhead deck of passenger ships and the freeboard deck of cargo ships. The valve shall be located at the collision bulkhead on either the forward or aft side, provided the space on the aft side is not a cargo space. The valve shall be of steel, bronze or other approved ductile material. Valves of ordinary cast iron or similar material are not acceptable. (SOLAS Reg. II-1/12.6.2)

1.8.2.3 If the forepeak is divided to hold two different kinds of liquids the Administration may allow the collision bulkhead to be pierced below the bulkhead deck of passenger ships and the freeboard deck of cargo ships by two pipes, each of which is fitted as required by 1.8.2.2 (paragraph (...) or 6.2), provided the Administration is satisfied that there is no practical alternative to the fitting of such a second pipe and that, having regard to the additional subdivision provided in the forepeak, the safety of the ship is maintained. (SOLAS Reg. II-1/12.6.3)

1.8.3 Openings and penetrations in watertight bulkheads and internal decks in cargo ships

Notes:

1. Requirements for openings and penetrations in watertight bulkheads below the bulkhead deck in passenger ships – see 17.1.1.
2. Requirements for internal watertight integrity of passenger ships above the bulkhead deck – see 17.1.2.

1.8.3.1 The number of openings in watertight subdivisions is to be kept to a minimum compatible with the design and proper working of the ship. Where penetrations of watertight bulkheads and internal decks are necessary for (...) piping, ventilation, (...) etc., arrangements are to be made to maintain the watertight integrity. The Administration may permit relaxation in the watertightness of openings above the freeboard deck, provided that it is demonstrated that any progressive flooding can be easily controlled and that the safety of the ship is not impaired. (SOLAS Reg. II-1/13-1.1)

1.8.4 Openings in the shell plating below the bulkhead deck of passenger ships and the freeboard deck of cargo ships

Note:

See also 2.2.2 to 2.2.12 (requirements of the *International Convention on Load Lines*).

1.8.4.1 The number of openings in the shell plating shall be reduced to the minimum compatible with the design and proper working of the ship. (SOLAS Reg. II-1/15.1)

1.8.4.2 The arrangement and efficiency of the means for closing any opening in the shell plating shall be consistent with its intended purpose and the position in which it is fitted and generally to the satisfaction of the Administration. (SOLAS Reg. II-1/15.2)

1.8.4.3 The number of scuppers, sanitary discharges and other similar openings in the shell plating shall be reduced to the minimum either by making each discharge serve for as many as

possible of the sanitary and other pipes, or in any other satisfactory manner. (SOLAS Reg. II-1/15.7)

1.8.4.4 Materials readily rendered ineffective by heat shall not be used for overboard scuppers, sanitary discharges, and other outlets which are close to the waterline and where the failure of the material in the event of fire would give rise to danger of flooding. (SOLAS Reg. II-2/11.5)

1.8.4.5 All inlets and discharges in the shell plating shall be fitted with efficient and accessible arrangements for preventing the accidental admission of water into the ship. (SOLAS Reg. II-1/15.8.1)

1.8.4.6 Subject to the requirements of the *International Convention on Load Lines* in force, and except as provided in 1.8.4.8 (paragraph 8.3), each separate discharge led through the shell plating from spaces below the bulkhead deck of passenger ships and the freeboard deck of cargo ships shall be provided with either one automatic non-return valve fitted with a positive means of closing it from above the bulkhead deck of passenger ships and the freeboard deck of cargo ships or with two automatic non-return valves without positive means of closing, provided that the inboard valve is situated above the deepest subdivision draught and is always accessible for examination under service conditions. Where a valve with positive means of closing is fitted, the operating position above the bulkhead deck of passenger ships and the freeboard deck of cargo ships shall always be readily accessible and means shall be provided for indicating whether the valve is open or closed. (SOLAS Reg. II-1/15.8.2.1)

1.8.4.7 The requirements of the *International Convention on Load Lines* in force shall apply to discharges led through the shell plating from spaces above the bulkhead deck of passenger ships and the freeboard deck of cargo ships. (SOLAS Reg. II-1/15.8.2.2)

1.8.4.8 Machinery space, main and auxiliary sea inlets and discharges in connection with the operation of machinery shall be fitted with readily accessible valves between the pipes and the shell plating or between the pipes and fabricated boxes attached to the shell plating. In manned machinery spaces these valves may be controlled locally and shall be provided with indicators showing whether they are open or closed. (SOLAS Reg. II-1/15.8.3)

Note:

For the location of controls of inlet and discharge valves in periodically unattended machinery spaces – see 18.3.3.

1.8.4.9 All shell fittings and valves required by 1.8.4 (this regulation) shall be of steel, bronze or other approved ductile material. Valves of ordinary cast iron or similar material are not acceptable. All pipes to which this regulation refers shall be of steel or other equivalent material to the satisfaction of the Administration. (SOLAS Reg. II-1/15.8.5)

1.8.5 Construction and initial tests of watertight closures

1.8.5.1 The design, materials and construction of all watertight closures such as (...) valves and pipes, referred to in these regulations shall be to the satisfaction of the Administration. (SOLAS Reg. II-1/16.1.1)

1.8.5.2 Such valves, (...) shall be suitably marked to ensure that they may be properly used to provide maximum safety. (SOLAS Reg. II-1/16.1.2)

1.9 Penetrations in fire-resisting divisions and prevention of heat transmission

1.9.1 Where "A" class divisions are penetrated, such penetrations shall be tested in accordance with the *Fire Test Procedures Code* (...). In the case of ventilation ducts, paragraphs 7.2.2 and 7.4.1 (7.1.2 and 7.3.1) apply. However, where a pipe penetration is made of steel or equivalent material

having a thickness of 3 mm or greater and a length of not less than 900 mm (preferably 450 mm on each side of the division), and no openings, testing is not required. Such penetrations shall be suitably insulated by extension of the insulation at the same level of the division. (SOLAS Reg. II-2/9.3.1)

1.9.2 Where "B" class divisions are penetrated for the passage of (...), pipes, trunks, ducts, etc., or for the fitting of ventilation terminals, (...) and similar devices, arrangements shall be made to ensure that the fire resistance is not impaired subject to the provisions of 7.4.2. (paragraph 7.3.2). Pipes other than steel or copper that penetrate "B" class divisions shall be protected by either:

- .1 a fire tested penetration device, suitable for the fire resistance of the division pierced and the type of pipe used; or
- .2 a steel sleeve, having a thickness of not less than 1.8 mm and a length of not less than 900 mm for pipe diameters of 150 mm or more and not less than 600 mm for pipe diameters of less than 150 mm (preferably equally divided to each side of the division). The pipe shall be connected to the ends of the sleeve by flanges or couplings; or the clearance between the sleeve and the pipe shall not exceed 2.5 mm; or any clearance between pipe and sleeve shall be made tight by means of non-combustible or other suitable material. (SOLAS Reg. II-2/9.3.2)

Notes:

1. For the passage of plastic pipes through "A" and "B" class divisions – see 1.7/4.6.7.
2. See also 1.4.7 and 1.4.9.

1.9.3 Uninsulated metallic pipes penetrating "A" or "B" class divisions shall be of materials having a melting temperature which exceeds 950°C for "A-0" and 850°C for "B-0" class divisions. (SOLAS Reg. II-2/9.3.3)

1.9.4 To prevent heat transmission at intersections and terminal points of the required thermal barriers – see *Part V*, 2.2.6.

1.10 Arrangement of systems

1.10.1 (...) piping systems and fittings shall be of a design and construction adequate for the service for which they are intended and shall be so installed and protected as to reduce to a minimum any danger to persons on board, due regard being paid to moving parts, hot surfaces and other hazards. The design shall have regard to materials used in construction, the purpose for which the equipment is intended, the working conditions to which it will be subjected and the environmental conditions on board. * (SOLAS Reg. II-1/26.1)

* Refer to *Guidelines for engine-room lay-out, design and arrangement* (MSC/Circ. 834).

1.10.2 Spaces where systems are installed shall be so designed and arranged to ensure the compliance with occupational health and safety requirements and to ensure the seafarer well-being, capabilities and task performance with respect to lighting, ventilation, vibration, noise, means of access and egress taking account the ambient conditions. Recommendations in this respect are contained in IACS REC. 132.

1.10.3 Systems and their components shall be so arranged as to provide free access to them for attendance, repairs in case of failure, as well as dismantling and removal from the ship.

1.10.4 The arrangement in machinery spaces shall be such as to provide passages from the control stations and attendance positions to the means of escape. The width of passages over the

whole length shall be at least 600 mm. In ships of less than 1000 tonnes gross tonnage, the width of passages may be reduced to 500 mm.

1.10.5 Pipes passing through cargo holds, chain lockers and other spaces where they are liable to mechanical damage shall be effectively protected.

1.10.6 Pipes shall not be led through the space where the main gyrocompass is installed, with the exception of pipes used for cooling it.

1.10.7 It is not recommended to lead any pipes through refrigerated spaces unless they are intended to serve these spaces. Where such leading is indispensable, the pipes shall be insulated. In the spaces there shall be no sections of pipes where water may collect and freeze.

1.10.8 Drinking water pipes may be led through oil tanks only in tight tunnels, forming an integral part of the tank structure.

1.10.9 Pipes shall not be led through the radio room.

1.10.10 Pipes carrying chemically aggressive media shall not be led through spaces used for the carriage of dangerous materials.

1.10.11 In no case pipes subjected to pressure shall be led above and behind the main or emergency switchboards, or the control panels of important arrangements and machinery.

In front of and alongside the switchboards and control panels such pipes may be led at a distance of at least 1500 mm.

1.10.12 Pipes shall not be led through special electrical spaces (definition – see *Part VIII*, 1.2) and accumulator battery rooms, with the exception of pipes of the carbon dioxide fire extinguishing system and pipes serving the electrical equipment installed in such spaces.

1.10.13 Special consideration shall be given to the design, construction and installation of propulsion machinery systems so that any mode of their vibrations shall not cause undue stresses in this machinery in the normal operating ranges. (SOLAS Reg. II-1/26.8)

1.10.14 Pipes should be properly aligned, supported and secured to the ship structure. They should not exert undue load on the equipment they are connected to. Means used to secure pipes shall not cause stresses therein due to thermal expansion, deformation of ship structure, or vibration.

1.10.15 The pipes conveying hot media as well as long pipes led along the ship shall be fitted with expansion joints or sufficient number of bends securing compensation and having radii not less than $2.5d$ (d – outside diameter of the pipe). shall be employed. Where no tunnels are used in leading the pipes through tanks, compensation shall be ensured by means of bends within the tanks. Where pipes are led in tunnels, it is recommended that the compensation bends be situated outside the tunnels.

1.11 Insulation of pipes and ducts

1.11.1 Surfaces with temperatures above 220°C which may be impinged as a result of a fuel system failure shall be properly insulated. (SOLAS Reg. II-2/4.2.2.6.1)

Note:

The above provision also applies in the case of lubricating oil systems failure. (SOLAS Reg. II-2/4.2.3.1)

1.11.2 Insulating materials shall be non-combustible, except in cargo spaces, mail rooms, baggage rooms and refrigerated compartments of service spaces. Vapour barriers and adhesives

used in conjunction with insulation, as well as the insulation of pipe fittings for cold service* systems, need not be of non-combustible materials, but they shall be kept to the minimum quantity practicable and their exposed surfaces shall have low flame spread characteristics. (SOLAS Reg. II-2/5.3.1.1)

*** IACS and IMO interpretation**

Cold service is understood to mean refrigeration systems and chilled water piping for air conditioning systems. (IACS UI SC102, MSC/Circ.1120)

1.11.3 (...) for all ships, new installation of materials which contain asbestos shall be prohibited. (SOLAS Reg. II-1/3-5.2)

Note:

For clarification and interpretation of new installation see: IACS UI SC249 and MSC.1/Circ.1426/Rev.1.

1.11.4 (5) The insulation of hot surfaces should be of a type and so supported that it will not crack or deteriorate when subject to vibrations. (IACS REC. 58)

1.11.5 The insulation shall be protected against mechanical damage.

1.11.6 In spaces where penetration of oil products is possible, the surface of insulation* shall be impervious to oil or oil vapours. (SOLAS Reg. II-2/4.4.3)

*** IMO interpretation**

The fire insulation in such spaces can be covered by metal sheets (not perforated) or by vapour barrier glass cloth accurately sealed at the joint. (MSC/Circ.1120)

1.12 Protection against corrosion

1.12.1 Upon completion of bending and welding, steel pipes of bilge, ballast and sea-water systems, air, sounding and overflow pipes of water tanks and ballast/fuel tanks shall be protected against corrosion by a method agreed with PRS.

1.12.2 Where bottom and side fittings or their parts are made of copper alloys, provision shall be made for protection of the shell plating and all other elements being in contact with the said fittings against electrolytic corrosion.

1.12.3 Where galvanized sea-water pipes are connected to copper alloy casings of pumps, units, heat exchangers and elements of fittings, provision shall be made for protection against electrolytic corrosion.

1.12.4 Where steel piping of refrigerant or cooling medium and their connecting elements are not made of stainless steel, they shall be galvanized outside or otherwise protected against corrosion with equivalent means. The surfaces being in contact with refrigerant or cooling medium shall not be galvanized.

1.12.5 Ventilation ducts shall be protected against corrosion or made of corrosion resistant material.

1.13 Protection against overpressure

1.13.1 Where the pressure is likely to develop in excess of the working pressure, the piping shall be provided with means preventing the pressure in the pipeline to rise above the working pressure.

1.13.2 Where provision is made for a reducing valve on the pipeline, a pressure gauge and safety valve shall be installed thereafter. An arrangement for bypassing the reducing valve is recommended.

1.13.3 Where main or auxiliary machinery including pressure vessels or any parts of such machinery are subject to internal pressure and may be subject to dangerous overpressure, means shall be provided where practicable to protect against such excessive pressure. (SOLAS Reg. II-1/27.2)

1.14 Valves and instrumentation

1.14.1 Covers of valves with internal diameter of more than 32 mm, equipped with turning spindles, shall be secured to the bodies by bolts or studs.

1.14.2 Screwed-on covers of valves shall be effectively secured against loosening.

1.14.3 The nut of cock plug shall be secured against unscrewing from the taper.

1.14.4 Remote controlled valves, operating with auxiliary source of power, the exception of those mentioned in 1.14.5, shall have local manual control, the operation of which shall be independent of the remote control. Manual control of the valves shall not render any failure in the remote control system.

1.14.5 Construction of the remote controlled valves shall be such as to ensure that in the case of failure of remote control system the valves remain in position that not render any state of emergency to the ship or they automatically set to such position.

1.14.6 Valves installed inside cargo tanks shall not be compressed air controlled.

1.14.7 Hydraulically controlled valves installed inside cargo tanks shall be so designed as to be capable of being emergency controlled by means of a hand operated pump. The pump shall be connected by a separate line at a place suitable for emergency control of each valve of the system or directly to the valves' actuators.

1.14.8 The tank containing working liquid of hydraulic control system of the valves installed inside cargo tanks shall be located above the cargo tanks upper level, as high as practicable, whereas all the hydraulic installation pipes shall be led to the cargo tanks in their upper part. Moreover, the tank shall be provided with an air pipe terminating in a safe place on the open deck and fitted with a flame arrester.

Audible and visual alarms of the low level of liquid in the tank shall be provided.

1.14.9 Shut-off devices shall be fitted with nameplates clearly specifying their purpose.

1.14.10 For remote controlled valves, nameplates specifying their purpose, as well as the indications (valve open/valve closed), shall be provided in the control stations. Where the remote control is intended for closing the valves only, such indicators need not be provided.

1.14.11 Valve chests and manually controlled valves shall be situated in positions always accessible during the normal operation of the ship.

1.14.12 Instruments, with the exception of liquid thermometers, shall be checked and accepted by a competent administration body in accordance with the state rules in force.

1.14.13 Piping systems shall be fitted with instruments necessary for monitoring their proper operation. When choosing the type and number of the instruments, guidance provided by

manufacturers of the mechanisms and equipment employed in particular installation shall be taken into account.

1.15 Sea chests

1.15.1 Sea-water inlet valves shall be placed directly on the bottom or side sea chests.

1.15.2 In the design and construction of sea chests care shall be taken to minimize the biofouling risks and transfer of invasive aquatic species in accordance with the guidance contained in IMO Resolution MEPC.207(62).

1.15.3 Access shall be provided to the inside of the bottom and side sea chests by means of removable covers or gratings.

1.15.4 Arrangement of the sea inlet and discharge openings in the ship's shell plating shall preclude:

- possibility of sucking the drains, ashes and other wastes by sea-water pumps;
- passing of discharged water and drains into the ship spaces through the side scuttles and into launched lifeboats and liferafts; where such arrangement of the openings is not practicable, the openings shall be fitted with arrangements that would prevent water from passing into the ship spaces, lifeboats and liferafts.

1.15.5 Openings in the ship shell plating for the bottom and side sea chests shall be fitted with protective gratings; alternatively, holes or slots may be made in the ship's hull. The total area of the holes or slots shall not be less than 2.5 times the total cross-sectional area of the installed sea-water inlet valves. The diameter of holes or width of slots in the gratings or shell plating shall be about 20 mm.

1.15.6 The bottom sea chests shall be provided with arrangements for clearing the gratings with steam or compressed air. Screw-down non-return valves shall be fitted on the clearing pipes. The steam or compressed air pressure shall not exceed 0.5 MPa.

1.15.7 Bottom and side valves and fittings shall be installed on welded pads. The holes for the fastening bolts or studs shall not be of through type.

1.15.8 The valves and fittings are allowed to be installed on the welded distance pieces, provided the latter are of rigid construction and of a minimum length. The wall thickness of a distance piece shall not be less than the minimum thickness of the shell plating at the ship ends; however, it need not be more than 12 mm.

1.15.9 Bottom and side shell fittings shall have flange connections to allow a pipe to be dismantled while maintaining the ship hull watertight integrity. Spindles and closing parts of the bottom and side valves and fittings shall be made of materials resistant to the corrosive effect of sea-water.

1.15.10 Bottom and side shell valves and fittings shall meet relevant requirements of 1.8.4.

1.16 Ambient conditions

The systems, associated machines and devices shall remain operational under the conditions defined in 1.16.1 to 1.16.3 for their related installations and components.

1.16.1 Main propulsion machinery and all auxiliary machinery essential to the propulsion and the safety of the ship shall, as fitted in the ship, be designed to operate when the ship is upright and when inclined at any angle of list up to and including 15° either way under static conditions

and 22.5° under dynamic conditions (rolling) either way and simultaneously inclined dynamically (pitching) 7.5° by bow or stern. The Administration may permit deviation from these angles, taking into consideration the type, size and service conditions of the ship. (SOLAS Reg. II-1/26.6)

1.16.2 Ambient conditions – inclinations

IACS UR M46

1.16.2.1 The ambient conditions specified under 1.16.2.2 (M46.2) are to be applied to the layout, selection and arrangement of all shipboard machinery, equipment and appliances to ensure proper operation. (M46.1)

1.16.2.2 Inclinations (M46.2)

Installations, components	Angle of inclination [°] ²			
	Athwartships		Fore-and-aft	
	static	dynamic	static	dynamic
Main and auxiliary machinery	15	22.5	5 ⁴	7.5
Safety equipment, e.g. emergency power installations, emergency fire pump and their devices Switch gear, electrical and electronic appliances ¹ and remote control systems	22.5 ³	22.5 ³	10	10
Notes:				
1. No undesired switching operations or operational changes are to occur.				
2. Athwartships and fore-end-aft inclinations may occur simultaneously.				
3. In ships for the carriage of liquefied gases and of chemicals the emergency power supply must also remain operable with the ship flooded to a final athwartships inclination up to maximum of 30°.				
4. Where the length of the ship exceeds 100m, the fore-and-aft static angle of inclination may be taken as 500/L degrees where L = length of the ship, in metres, as defined in 1.2.35 (UR S2).				

The Society may consider deviations from these angles of inclination taking into consideration the type, size and service conditions of the ship.

END OF IACS UR M46

1.16.3 Ambient conditions – temperatures

IACS UR M40

1.16.3.1 The ambient conditions specified under 1.16.3.2 (M40.2) are to be applied to the layout, selection and arrangement of all shipboard machinery, equipment and appliances as to ensure proper operation. (M40.1)

1.16.3.2 Temperatures (M40.2)

Air

Installations, components	Location arrangements	Temperature range (°C)
Machinery and electrical installations ¹	In enclosed spaces	0 to +45 ²
	On machinery components, boilers In spaces subject to higher and lower temperatures	According to specific local conditions

	On the open deck	-25 to +45 ²
--	------------------	-------------------------

Water

Coolant	Temperature (°C)
Seawater	+32 ²
Charge air coolant inlet to charge air cooler	see UR M28

Notes:

1. Electronic appliances are to be suitable for proper operation even with an air temperature of +55°C.
2. The Classification Society may approve other temperatures in the case of ships not intended for unrestricted service.

Note:

UR M28 concerns ambient reference conditions for determining the power of main and auxiliary reciprocating internal combustion engines – see *Part VII*, 2.1.4.

END OF IACS UR M40

CHAPTER 2

2 DRAINAGE SYSTEMS

Note:

Additional requirements for the drainage of passenger ships – see 17.1.3.

2.1 General requirements

2.1.1 Any ship's compartment shall be capable of being drained in accordance with provisions of this *Chapter*.

2.1.2 Tanks used for the carriage or storage of liquids shall be capable of being pumped out by their related piping system.

2.1.3 Cargo holds used for alternative carriage of dry cargo, liquid cargo and ballast water shall be capable of being pumped out by the cargo, ballast and bilge system. Cargo and ballast filling and suction pipes as well as bilge suction pipes shall be fitted with arrangements for blank flanging.

2.1.4 For cargo holds which are not weathertight (e.g. open top container cargo holds) account should be taken of the additional water which may enter such holds. High bilge level alarms shall be provided in these spaces.

2.1.5 Compartments which are not drained by means of the bilge piping system shall be provided with other means to remove water.

2.1.6 Cargo decks where water may accumulate due to sea splashes, rain, activation of fire extinguishing systems, etc. shall be capable of being effectively drained to prevent formation of free surfaces.

2.1.7 Open decks shall be provided with efficient means for water drainage.

2.2 Scuppers

Note:

Requirements of this *Section 2.2* apply to all drain pipes discharging overboard and having open ends/inlets inboard (scuppers draining decks, sanitary drainage discharges, gravity drains from topside ballast tanks, etc.).

2.2.1 Scuppers shall comply with the applicable SOLAS requirements provided in 1.8.4.

2.2.2 Discharges led through the shell either from spaces below the freeboard deck or from within superstructures and deckhouses on the freeboard deck fitted with doors complying with the requirements of regulation 12 shall, except as provided in 2.2.9, (paragraph (2)) be fitted with efficient and accessible means for preventing water from passing inboard. Normally each separate discharge shall have one automatic non-return valve with a positive means of closing it from a position above the freeboard deck. Where the inboard end of the discharge pipe is located at least 0.01L above the Summer Load Line, the discharge may have two automatic non-return valves without positive means of closing. Where that vertical distance exceeds 0.02L, a single automatic non-return valve without positive means of closing may be accepted. The means for operating the positive action valve shall be readily accessible and provided with an indicator showing whether the valve is open or closed. (LL, Annex 1, Reg. II/22(1)(a))

Notes:

1. Doors complying with the requirements of regulation 12 are doors of steel or equivalent material, weathertight when closed and so constructed and fitted that strength of the bulkhead in way of their location is not impaired.
2. Length of the ship *L* – see 1.2.33.

IACS interpretation

AA. It is considered that an acceptable equivalent to one automatic non-return valve with a positive means of closing from a position above the freeboard deck would be one automatic non-return valve and one sluice valve controlled from above the freeboard deck.

Where two automatic non-return valves are required, the inboard valve must always be accessible under service condition, i.e., the inboard valve should be above the level of the tropical load water line. If this is not practicable, then, provided a locally controlled sluice valve is interposed between the two automatic non-return valves, the inboard valve need not be fitted above the LWL.

Where sanitary discharges and scuppers lead overboard through the shell in way of machinery spaces, the fitting to shell of a locally operated positive closing valve, together with non-return valve inboard, is considered to provide protection equivalent to the requirements of Regulation 22(1).

It is considered that the requirements of Regulation 22(1) for non-return valves are applicable only to those discharges which remain open during the normal operation of a vessel. For discharges which must necessarily be closed at sea, such as gravity drains from topside ballast tanks, a single screw down valve operated from the deck is considered to provide efficient protection.

The inboard end of a gravity discharge which leads overboard from an enclosed superstructure or space is to be located above the water line formed by a 5 degree heel, to port or starboard, at a draft corresponding to the assign summer freeboard.

It is considered that the position of the inboard end of discharges should be related to the timber summer load waterline when timber freeboard is assigned.

Refer to the attached **Table 22.1** for the acceptable arrangements of scuppers and discharges.

(...) (deleted text concerning garbage chutes)

BB. Where plastic pipes are used for sanitary discharges and scuppers, they are also subject to the requirements of the Table, and the valve at the shell is to be operated from outside the space in which the valve is located.

Where such plastic pipes are located below the summer waterline (timber summer load waterline), the valve is to be operated from a position above the freeboard deck.

The portion of discharge line from the shell to the first valve as well as shell fittings and valves shall be of steel, bronze or other approved ductile material.

The approval of plastic piping in any location will be subject to the consideration of strength and fire hazards involved with special reference to penetrations through bulkheads, decks or other significant compartment boundaries.

Attention must also be paid to valid fire technical regulations. (IACS UI LL11)

2.2.3 One automatic non-return valve and one sluice valve controlled from above the freeboard deck instead of one automatic non-return valve with a positive means of closing from a position above the freeboard deck, is acceptable. (LL, Annex 1, Reg. II/22(1)(b))

2.2.4 Where two automatic non-return valves are required, the inboard valve shall always be accessible for examination under service conditions (i.e., the inboard valve shall be above the level of the Tropical Load Line). If this is not practicable, the inboard valve need not be located above the Tropical Load Line, provided that a locally controlled sluice valve is fitted between the two automatic non-return valves. (LL, Annex 1, Reg. II/22(1)(c))

2.2.5 Where sanitary discharges and scuppers lead overboard through the shell in way of machinery spaces, a locally operated positive closing valve at the shell, together with a non-return valve inboard, is acceptable. The controls of the valves shall be in an easily accessible position. (LL, Annex 1, Reg. II/22(1)(d))

2.2.6 The position of the inboard end of discharges shall be related to the Summer Timber Load Line when a timber freeboard is assigned. (LL, Annex 1, Reg. II/22(1)(e))

2.2.7 The requirements for non-return valves are applicable only to those discharges which remain open during the normal operation of a ship. For discharges which are to be kept closed at sea, a single screw down valve operated from the deck is acceptable. (LL, Annex 1, Reg. II/22(1)(f))

2.2.8 Table 22.1 provides the acceptable arrangements of scuppers and discharges.

Table 22.1

Discharges coming from enclosed spaces below the freeboard deck or on the freeboard deck		Discharges coming from other spaces	
General requirement Reg. 22(1) where inboard end < 0,01L above SWL	Discharges through machinery space	Discharges coming from other spaces	
		Alternatives (Reg. 22(1)) where inboard end > 0,02L above SWL	Outboard end > 450 mm below FB deck or < 600 mm above SWL Reg. 22(3)
Superstructure or deckhouse deck			

Symbols:
 inboard end of pipes
 outboard end of pipes
 pipes terminating on the open deck

Non-return valve without positive means of closing
 Non-return valve with positive means of closing
 valve controlled locally

remote control
 normal thickness
 substantial thickness

(LL, Annex 1, Reg. II/22(1)(g))

Notes:

FB deck – freeboard deck
SWL – summer load line

TWL – tropical load line

2.2.9 Scuppers led through the shell from enclosed superstructures used for the carriage of cargo shall be permitted only where the edge of the freeboard deck is not immersed when the ship heels 5° either way. In other cases the drainage shall be led inboard in accordance with the requirements of the International Convention for the Safety of Life at Sea in force. (LL, Annex 1, Reg. II/22(2))

Note:

Relevant requirements of SOLAS Convention – see 2.4.3.14 and 2.4.3.15.

2.2.10 Scuppers and discharge pipes originating at any level and penetrating the shell either more than 450 mm below the freeboard deck or less than 600 mm above the Summer Load Line shall be provided with a non-return valve at the shell. This valve, unless required by 2.2.2 to 2.2.8, (paragraph (1)) may be omitted if the piping is of substantial thickness (see 2.2.13 (paragraph (7) below)). (LL, Annex 1, Reg. II/22(4))

2.2.11 Scuppers leading from superstructures or deckhouses not fitted with doors complying with the requirements of regulation 12 shall be led overboard. (LL, Annex 1, Reg. II/22(5))

Note:

Doors complying with the requirements of regulation 12 are doors of steel or equivalent material, weathertight when closed and so constructed and fitted that strength of the bulkhead in way of their location is not impaired.

2.2.12 All shell fittings and the valves required by this regulation shall be of steel, bronze or other approved ductile material. Valves of ordinary cast iron or similar material are not acceptable. All pipes to which this regulation refers shall be of steel or other equivalent material to the satisfaction of the Administration. (LL, Annex 1, Reg. II/22(6))

2.2.13 Scupper and discharge pipes:

(a) For scupper and discharge pipes, where substantial thickness is not required:

- (i) for pipes having an external diameter equal to or less than 155 mm, the thickness shall not be less than 4.5 mm;
- (ii) for pipes having an external diameter equal to or more than 230 mm, the thickness shall not be less than 6 mm.

Intermediate sizes shall be determined by linear interpolation.

(b) For scupper and discharge pipes, where substantial thickness is required:

- (i) for pipes having an external diameter equal to or less than 80 mm, the thickness shall not be less than 7 mm;
- (ii) for pipes having an external diameter of 180 mm, the thickness shall not be less than 10 mm;
- (iii) for pipes having an external diameter equal to or more than 220 mm, the thickness shall not be less than 12.5 mm.

Intermediate sizes shall be determined by linear interpolation. (LL, Annex 1, Reg. II/22(7))

Note:

IACS UI LL36 paragraphs (a)(i) and (b) contain technically identical requirements as the above LL, Annex I, Reg. II/22(7) hence the UI's requirements are not repeated here.

2.3 Bilge systems

2.3.1 General requirements for cargo and passenger ships

2.3.1.1 An efficient bilge pumping system shall be provided, capable of pumping from and draining any watertight compartment other than a space permanently appropriated for the carriage of fresh water, water ballast, oil fuel or liquid cargo and for which other efficient means of pumping are provided, under all practical conditions. Efficient means shall be provided for draining water from insulated holds. (SOLAS Reg. II-1/35-1.2.1)

This requirement does not apply to the spaces of ammonia refrigerating machinery, peaks, pump rooms and cofferdams of tankers drained by individual pumps.

2.3.1.2 Sanitary, ballast and general service pumps may be accepted as independent power bilge pumps if fitted with the necessary connections to the bilge pumping system. (SOLAS Reg. II-1/35-1.2.2)

2.3.1.3 Centrifugal bilge pumps shall be of self-priming type or provided with air ejection arrangements. It is recommended that one of the required bilge pumps be of piston type.

2.3.1.4 The internal diameter of the bilge main and of branch suctions shall not be less than 50 mm.

In no case the internal diameter of the bilge main and of the branch bilge pipes connected directly to the pump shall be less than that of the suction inlet of the pump.

2.3.1.5 Cross-sectional area of the pipe connecting the distribution box with the bilge main shall not be less than the total cross-sectional area of the two largest branch bilge suctions connected to this chest, however not greater than the cross-sectional area of the bilge main.

2.3.1.6 All bilge pipes used in or under coal bunkers or fuel storage tanks or in boiler or machinery spaces, including spaces in which oil-settling tanks or oil fuel pumping units are situated, shall be of steel or other suitable material. (SOLAS Reg. II-1/35-1.2.3)

2.3.1.7 Where it is necessary to lead bilge pipes through oil fuel, lubricating oil, boiler feed water or drinking water tanks, the pipes shall be led inside tight tunnels forming an integral part of such tanks. Leading pipes without tunnels is allowed, provided that within the tank pipes are seamless and connected by means of permanent joints. Where the use of detachable joints is indispensable, they shall be a flange type with gaskets resistant to the effect of medium stored in the tank.

2.3.1.8 The arrangement of the bilge and ballast pumping system shall be such as to prevent the possibility of water passing from the sea and from water ballast spaces into the cargo and machinery spaces, or from one compartment to another. Provision shall be made to prevent any deep tank having bilge and ballast connections being inadvertently flooded from the sea when containing cargo, or being discharged through a bilge pump when containing water ballast. (SOLAS Reg. II-1/35-1.2.4)

For this purpose the suction valves of bilge piping distribution chests as well as the valves on branch suctions connected directly to the bilge main shall be of shut-off non-return type. Non-return valves that are not spring loaded shall not be used. Other arrangements are subject to PRS consideration in each particular case.

2.3.1.9 The arrangement of bilge pipes shall be such as to enable one of the pumps to be operated while the remaining pumps are under repair or being used for other services.

2.3.1.10 As far as practicable bilge pipes shall be led outside double bottom space. Where pipes are led within double bottom space, the open ends of suction pipes shall be fitted with non-return valves.

Bilge pipes led inside double bottom tunnel shall be located as high as practicable.

2.3.1.11 In the case of remote or automatically controlled bilge system, where suctions from several spaces are connected to one main line and where the length of such main situated inside the double bottom exceeds 35 m, the main shall be subdivided by means of remote controlled full-flow valves into sections of a length not exceeding 35 m, or other arrangement ensuring the possibility of use of one section of the main when the other one is damaged shall be provided.

2.3.1.12 All distribution boxes and manually operated valves in connection with the bilge pumping arrangements shall be in positions which are accessible under ordinary circumstances. (SOLAS Reg. II-1/35-1.2.5)

2.3.2 General requirements for cargo ships

2.3.2.1 At least two power pumps connected to the main bilge system shall be provided, one of which may be driven by the propulsion machinery. If the Administration is satisfied that the safety of the ship is not impaired, bilge pumping arrangements may be dispensed with in particular compartments. (SOLAS Reg. II-1/35-1.4)

2.3.2.2 One of the bilge pumps may be a main engine-driven pump, or a water or steam ejector, provided the steam boiler is always under pressure.

For ships of restricted service, receiving in their symbol of class additional mark **II** or **III**, one of the pumps may be driven by the main engine, and the other may be a hand pump or an ejector.

2.3.2.3 Capacity Q of each required bilge pump shall not be less than that determined in accordance with the following formula:

$$Q = \frac{5.65}{1000} d^2 \text{ [m}^3/\text{h]}$$

where:

d – internal diameter of the bilge main [mm], determined in accordance with formula provided in **2.3.2.5**.

Two pumps of combined capacity not less than that calculated from the above mentioned formula may replace one of the bilge pumps.

2.3.2.4 For the drainage of non-propelled ships having no power-driven auxiliaries, at least two hand pumps shall be installed, and these shall have a combined capacity not less than that specified in Table 2.4.3.

Table 2.4.3
Combined capacity Q of hand bilge pumps

0.8 LBD [m ³]	Combined capacity of pumps [m ³ /h]
below 600	8
from 600 up to 1100	10
above 1100 up to 1800	12

Note:

L , B and D – see 2.3.2.5.

The pumps shall be situated above the bulkhead deck and shall have a sufficient suction head. In non-propelled ships having a power source, it is recommended that power pumps be installed in the number and with the capacity in accordance with the requirements for hand pumps.

2.3.2.5 In case of cargo ships the internal diameter d of the bilge main and of the branch suction, connected directly to the pumps shall be calculated according to the following formula. However, the actual internal diameter of the bilge main may be rounded off to the nearest standard size:

$$d = 1.68\sqrt{L(B + D)} + 25 \text{ [mm]}$$

where:

- L is the Rule length, [m] – see 1.2.34;
- B is the moulded breadth of the ship, [m];
- D is the moulded depth of the ship to the bulkhead deck, [m].

In no case the internal diameter d of the bilge main shall be less than the internal diameter d_b calculated in accordance with 2.3.2.7 of any branch bilge pipes connected to the bilge main.

2.3.2.6 For dredgers and hopper barges having inner dredging holds, internal diameter d of the bilge main and of the branch suction, connected directly to the pumps, may be determined in accordance with the following formula:

$$d = 1.68\sqrt{L(B + D) - l_1(b + h)} + 25 \text{ [mm]}$$

where:

- L , B and D – see 2.3.2.5;
- l_1 is the length of dredging hold, [m];
- b is the width of dredging hold, [m].

2.3.2.7 Internal diameter d_b of the branch bilge pipes connected to the bilge main and the diameter of suction pipes of hand pumps shall not be less than that determined in accordance with the following formula:

$$d_b = 2.15\sqrt{l(B + D)} + 25 \text{ [mm]}$$

where:

- d_b is internal diameter of the branch bilge pipes
- B and D – see 2.3.2.5;
- l is the length of the compartment to be drained, measured over its bottom, [m].

2.3.3 General requirements for passenger ships

General requirements for passenger ships – see 17.1.3.

2.4 Drainage of various spaces

2.4.1 Machinery spaces

Notes:

1. Additional requirements for the drainage of periodically unattended machinery spaces – see 18.3.1 to 18.3.3
2. Additional requirements for the drainage of machinery spaces in passenger ships – see 17.1.3.

2.4.1.1 Where the machinery space has double bottom extending over its full length and forming side bilges, at least two bilge suction shall be provided at each side. One of the bilge suction, at each side, shall be directly connected to an independent bilge pump, the other to the bilge main.

2.4.1.2 Where tank top extends over the full length and breadth of the machinery space, at least two bilge suction located in bilge wells shall be provided at each side. One of the bilge suction,

at each side, shall be directly connected to an independent bilge pump, the other to the bilge main. The capacity of each bilge well shall be at least 0.20 m³; and the bilge well design shall fulfil the requirements specified in *Part II*, 6.2.11.

2.4.1.3 Where the machinery space is situated in the after part of the ship, the bilge suction shall be fitted near the front bulkhead; in the after part two bilge suction shall be provided. The number of bilge suction in the after part will depend on the after part shape and is subject to PRS acceptance in each particular case.

2.4.1.4 Where the machinery space has not double bottom and the bottom rise is 5° or more, at least two bilge suction shall be provided close to the ship's plane of symmetry. One of the bilge suction shall be directly connected to an independent bilge pump, the other to the bilge main. Where the bottom rise is less than 5°, additional bilge suction shall be provided at each side.

2.4.1.5 In addition to bilge suction, required in paragraphs from 2.4.1.1 to 2.4.1.4, bilge suction shall be installed in the log and echo sounder trunks, in the recesses of double bottom provided for the bedplates of engines and other machinery, as well as in other locations where due to the tank top structure water may accumulate.

2.4.1.6 The arrangement of bilge pipes shall be such as to enable draining the engine room through the suction connected directly to the pump, with other compartments being simultaneously drained by other pumps.

2.4.1.7 Where the engine room is separated, by watertight bulkheads, from other machinery spaces, the number and arrangement of branch suction in these spaces shall be such as in cargo holds (see 2.4.3). In ships having a mark of subdivision in their symbol of class, each of these spaces shall be provided with an additional branch suction connected directly to an independent bilge pump.

2.4.1.8 In ships propelled by electrical machinery, special arrangements for the drainage of bilge wells under main generators and propulsion motors, as well as for an automatic warning system signal activated when water in the wells exceeds the permissible level, shall be provided. Automatic means to effect the drainage of wells are recommended.

2.4.1.9 Bilge suction for normal drainage of machinery spaces and tunnels shall be fitted with readily accessible mud boxes. The pipes from mud boxes to the bilges shall be led as straight as practicable. The lower ends of these boxes shall not be fitted with strum boxes. The mud boxes shall be fitted with easy-to-open covers.

In ships of less than 500 gross tonnage, strainers may be used instead of mud boxes, provided they are readily accessible for clearing.

2.4.1.10 For self-propelled ships, provision shall be made for emergency drainage of the engine room.

In steam ships, the pipe for emergency drainage shall be directly connected to the condenser's main cooling pump and in motor ships to the cooling pump of the highest capacity. Such pipe shall be fitted with a shut-off non-return valve and the pipe inlet shall be situated at a level, which ensures drainage of the machinery space. The diameter of this pipe shall be at least two-third of the diameter of the condenser cooling pump inlet in steam ships and shall be equal to the diameter of the connected pump inlet in motor ships.

Where the pumps, specified above, are not suitable for operation as bilge pumps, the pipe for emergency drainage shall be connected to the largest available power pump not used directly for the bilge drainage. The capacity of this pump shall exceed that required in 2.3.2.3 by an amount

agreed with PRS. The diameter of the pipe shall be equal to the diameter of the pump inlet. The spindles of the shut-off non-return valves fitted to the suction pipes shall extend above the engine room floor and shall have the following name plates:

„Emergency drainage“

Fire pumps are permitted for emergency drainage, provided that the requirements specified in *Part V*, 3.2.2.1, are fulfilled.

For ships of restricted service, receiving in their symbol of class additional mark **II** or **III**, not provided with a pump of capacity greater than that of the bilge pump, emergency drainage need not be provided

2.4.1.11 Neither mud boxes nor strainers shall be installed on the emergency bilge suction.

2.4.1.12 Machinery spaces with refrigerating plant using refrigerant belonging to group II (i.e. toxic and flammable medium) and III (i.e. explosive or flammable medium) shall have a separate bilge system. The capacity of the system's bilge pump shall not be less than that of the water curtain system at the access door to the compartment. The discharge pipes of the bilge system shall be led directly overboard.

The engine room with refrigerating plant using refrigerant belonging to group I (i.e. non-flammable medium) may be drained by the main bilge system of the ship.

2.4.1.13 It is recommended that bilge system enables oily bilge water and non-oily bilge water to be transferred by means of separate pumps and piping.

2.4.1.14 Arrangements for machinery space oily water treatment and discharge

2.4.1.14.1 (...) any ship of 400 gross tonnage and above but less than 10,000 gross tonnage shall be fitted with oil filtering equipment complying with 2.4.1.14.5 (paragraph 6 of this regulation). Any such ship which may discharge into the sea ballast water retained in fuel oil tanks (...) shall comply with 2.4.1.14.2 (paragraph 2 of this regulation). (MARPOL, Reg. I/14.1)

2.4.1.14.2 (...) any ship of 10,000 gross tonnage and above shall be fitted with oil filtering equipment complying with 2.4.1.14.6 (paragraph 7 of this regulation). (MARPOL, Reg. I/14.2)

2.4.1.14.3 Ships, such as hotel ships, storage vessels, etc., which are stationary except for non-cargo-carrying relocation voyages need not be provided with oil filtering equipment. Such ships shall be provided with a holding tank having a volume adequate, to the satisfaction of the Administration, for the total retention on board of the oily bilge water. (...) (MARPOL, Reg. I/14.3)

2.4.1.14.4 The Administration shall ensure that ships of less than 400 gross tonnage are equipped, as far as practicable, to retain on board (...) oily mixtures or discharge them in accordance with the requirements (...). (MARPOL, Reg. I/14.4)

2.4.1.14.5 Oil filtering equipment referred to in 2.4.1.14.1 (paragraph 1 of this regulation) shall be of a design approved by the Administration and shall be such as will ensure that any oily mixture discharged into the sea after passing through the system has an oil content not exceeding 15 parts per million. In considering the design of such equipment, the Administration shall have regard to the specification recommended by the Organization*. (MARPOL, Reg. I/14.6)

* Refer to the *Recommendation on international performance and test specification for oily-water separating equipment and oil content meters* (resolution A.393(X)), or the *Guidelines and specifications for pollution prevention equipment for machinery space bilges of ships* (resolution MEPC.60(33)), *2011 Guidelines and specifications for add-on equipment for upgrading resolution MEPC.60(33) – compliant oil filtering equipment* (resolution MEPC.205(62)), or *Revised guidelines*

and specification for pollution prevention equipment for machinery space bilges of ships (resolution MEPC.107(49), as amended by resolution MEPC.285(70)).

2.4.1.14.6 Oil filtering equipment referred to in 2.4.1.14.2 (paragraph 2 of this regulation) shall comply with 2.4.1.14.5 (paragraph 6 of this regulation). In addition, it shall be provided with alarm arrangement to indicate when this level cannot be maintained. The system shall also be provided with arrangements to ensure that any discharge of oily mixtures is automatically stopped when the oil content of the effluent exceeds 15 parts per million. In considering the design of such equipment and approvals, the Administration shall have regard to the specification recommended by the Organization*. (MARPOL, Reg. I/14.7)

* Refer to the *Recommendation on international performance and test specification for oily-water separating equipment and oil content meters* (resolution A.393(X)), or the *Guidelines and specifications for pollution prevention equipment for machinery space bilges of ships* (resolution MEPC.60(33)), *2011 Guidelines and specifications for add-on equipment for upgrading resolution MEPC.60(33) – compliant oil filtering equipment* (resolution MEPC.205(62)), or *Revised guidelines and specification for pollution prevention equipment for machinery space bilges of ships* (resolution MEPC.107(49), as amended by resolution MEPC.285(70)).

2.4.1.14.7 Common arrangements for the discharge of oily bilge water and oil residue (sludge) to shore reception facilities through the standard discharge connection are acceptable if they comply with 3.1.1.3.2.

2.4.2 Tunnels

2.4.2.1 Each shaft tunnel and each pipe tunnel accessible for personnel shall be drained by a branch pipe led from the bilge well situated in the after part of the tunnel to the bilge main.

Additional suctions shall be provided in the fore part of the tunnel if there is a possibility of water being collected there.

2.4.2.2 The bilge suctions of the shaft tunnel shall be made in compliance with 2.4.1.9.

Bilge wells extending to the outer bottom may be used in the after part of the shaft tunnel in ships other than oil tankers.

2.4.3 Cargo holds and decks

Note:

Additional requirements for the drainage of cargo holds and decks in passenger ships – see 17.1.3.

2.4.3.1 Each cargo hold where the double bottom forms bilges at the wings, shall have at least one bilge suction at each side in the after part of the hold. The bilge wells installed in the double bottom shall not be deeper than necessary and, additionally, they shall fulfil the requirements specified in *Part II*, 6.2.11.

2.4.3.2 Where there is a double bottom within a cargo hold extending over the full breadth, at least one bilge suction each side, connected to a bilge well situated in the after part of the hold, shall be provided.

The capacity of the bilge wells shall not be less than 0.20 m³.

2.4.3.3 In holds where the inner bottom plating has inverse camber, provision shall be made for suctions situated at the centre line, in addition to the suctions situated at the wings.

Where a bilge well extends over the entire breadth of the hold, and the inverse camber exceeds 5°, only one branch suction may be led to such well.

2.4.3.4 Where an access manhole to the bilge well shall be provided, it shall be arranged as close to the suction strum box as practicable.

2.4.3.5 In the hold where there is no double bottom and the bottom rise is 5° or more, one bilge suction may be fitted near the centre line.

If the bottom rise is less than 5°, at least one suction at each side shall be provided.

2.4.3.6 Where the length of hold exceeds 35 m, fore and aft bilge suctions shall be provided.

The arrangement of suctions shall fulfil the requirements specified in 2.4.3.1 to 2.4.3.5.

2.4.3.7 At the narrow ends of cargo holds one bilge suction may be fitted.

2.4.3.8 Drain pipes may be led to the bilges of cargo holds from adjacent spaces situated below the bulkhead deck of the same watertight compartment. See also 2.4.4.2.

2.4.3.9 Where tight wooden panels or removable covers are provided over bilges in cargo holds, provision shall be made to enable free draining the water accumulated in the hold into bilges.

2.4.3.10 Branch suctions from cargo holds and other compartments shall be fitted with strum boxes or strainers with perforations from 8 to 10 mm in diameter. The combined area of such perforations shall not be less than twice the area of the relevant suction pipe. Strum boxes shall be so constructed that they can be cleared without dismantling any joint on the suction branch.

2.4.3.11 In cargo holds intended for the carriage of dry bulk cargoes (ore, apatite, etc.) constructional measures shall be taken to enable effective drainage of these holds when the cargo is carried.

2.4.3.12 For the drainage of cargo spaces intended for the carriage of dangerous goods – see *Part V*, 7.2.5.

2.4.3.13 Provision shall be made for the drainage of enclosed cargo spaces situated on the bulkhead deck of a passenger ship and on the freeboard deck of a cargo ship, provided that the Administration may permit the means of drainage to be dispensed with in any particular compartment of any ship or class of ship if it is satisfied that by reason of size or internal subdivision of those spaces the safety of the ship is not thereby impaired. For ships subject to the provisions of regulation II-1/1.1.1.1 (i.e. ships to which these *Rules* apply), for the special hazards associated with loss of stability when fitted with fixed pressure water-spraying fire-extinguishing systems refer to 17.3.1.2 (regulation II-2/20.6.1.4). (SOLAS Reg. II-1/35-1.2.6)

2.4.3.14 Where the freeboard to the bulkhead deck or the freeboard deck, respectively, is such that the deck edge is immersed when the ship heels more than 5°, the drainage shall be by means of a sufficient number of scuppers of suitable size discharging directly overboard*, fitted in accordance with the requirements of 1.8.4 (regulation 15) in the case of a passenger ship and requirements for scuppers, inlets and discharges of the *International Convention on Load Lines* in force in the case of a cargo ship. (SOLAS Reg. II-1/35-1.2.6.1)

*** IACS interpretation**

The drainage of such enclosed spaces to suitable spaces below deck is also permitted provided such drainage is arranged in accordance with the provisions 2.2.9 (of the Regulation 22(2), ICLL 1966 (1988 Protocol)). (IACS UI SC81)

2.4.3.15 Where the freeboard is such that the edge of the bulkhead deck or the edge of the freeboard deck, respectively, is immersed when the ship heels 5° or less, the drainage of the enclosed cargo spaces on the bulkhead deck or on the freeboard deck, respectively, shall be led to

a suitable space, or spaces, of adequate capacity, having a high water level alarm and provided with suitable arrangements for discharge overboard. In addition it shall be ensured that:

- .1 the number, size and disposition of the scuppers are such as to prevent unreasonable accumulation of free water;
- .2 the pumping arrangements required by this regulation for passenger ships or cargo ships, as applicable, take account of the requirements for any fixed pressure water-spraying fire extinguishing system;
- .3 water contaminated with petrol or other dangerous substances is not drained to machinery spaces or other spaces where sources of ignition may be present; and
- .4 where the enclosed cargo space is protected by a carbon dioxide fire extinguishing system the deck scuppers are fitted with means to prevent the escape of the smothering gas. (SOLAS Reg. II-1/35-1.2.6.2)

2.4.3.16 Provisions for the drainage of closed vehicle and ro-ro spaces and special category spaces shall also comply with 17.3.1.2 and 17.3.1.3 (regulations II-2/20.6.1.4 and II-2/20.6.1.5). (SOLAS Reg. II-1/35-1.2.6.3)

2.4.4 Refrigerated spaces

2.4.4.1 Provision shall be made for draining all spaces, trays, chutes and other places where water may accumulate.

2.4.4.2 Drain pipes from any non-refrigerated compartments shall not be led into the bilges of refrigerated spaces.

2.4.4.3 Each drain pipe from refrigerated spaces shall be fitted with a hydraulic seal, or with other equivalent closing arrangement. The head of liquid in the hydraulic seal shall be such that the arrangement is effective under any service conditions.

2.4.4.4 The hydraulic seals shall be placed in accessible positions outside the insulation. Where drain pipes from the tweendecks are led into a common bilge well, non-return valves shall be fitted at the ends of these pipes. Shut-off valves shall not be fitted to the pipes.

2.4.5 Deep tanks

2.4.5.1 Deep tanks intended also for the carriage of dry cargoes shall be fitted with bilge system branch suctions and effective means to disconnect the system from the tanks when oil fuel, ballast or liquid cargo is carried in the tanks, as well as to disconnect oil fuel system or liquid cargo piping when dry cargo is carried in the tanks shall be provided.

2.4.5.2 The arrangement of branch suctions shall fulfil the requirements specified in 2.4.4.

2.4.6 Cofferdams

2.4.6.1 Where cofferdams are capable of being filled with water, draining arrangements shall be provided.

2.4.6.2 The arrangement of branch suctions shall fulfil the requirements specified in 2.4.4.

2.4.7 Forepeaks and afterpeaks

Note:

Additional requirements for the drainage of peak compartments in passenger ships – see 17.1.3.

2.4.7.1 The peaks which are not used as tanks may be drained by means of separate hand pumps or water ejectors.

2.4.8 Other spaces

2.4.8.1 Chain locker and boatswain's store may be drained by means of hand pumps, water ejectors or other arrangements.

2.4.8.2 Drainage of steering gear rooms and other small compartments situated above the afterpeak may be carried out by means of hand pumps or water ejectors or, except for passenger ships, by means of drain pipes led into the shaft tunnel or machinery space bilges. The drain pipes shall be fitted with self-closing cocks located in readily accessible places.

The internal diameter of the drain pipes shall not be less than 39 mm.

2.4.8.3 Except the cases specified in 2.4.8.2, drain pipes shall not be led into the bilges of machinery space and shaft tunnel from the spaces situated in other watertight compartments below the bulkhead decks. Drain pipes from these spaces may be led into machinery spaces and shaft tunnels only if terminating into closed drain tanks. Where one tank is intended for the drainage of several watertight compartments and water can overflow from one flooded compartment into another, the drain pipes shall be fitted with non-return valves.

Drain tank shall be drained through a branch suction of the bilge main, and the branch or suction distribution box shall be fitted with non-return valve.

2.4.8.4 Drain pipes from the spaces situated in enclosed superstructures and deckhouses may be led to the bilges of machinery spaces or holds. In ships having a mark of subdivision in their symbol of class these pipes shall be fitted with valves controllable from a place above the margin line if, in case of flooding of the machinery space or hold, water could penetrate into the above spaces.

2.4.8.5 Drain pipes of the storerooms for explosives shall be fitted with valves controllable from the places situated outside these storerooms.

CHAPTER 3

3 OIL RESIDUE SYSTEM

3.1 Oil residue (sludge) tank

Requirements of 3.1 apply to ships of 400 gross tonnage and above. Ships of less than 400 gross tonnage shall be provided with the arrangements for oil residues retention on board, discharge of the residues to shore reception facilities and no connections which would enable either direct or indirect discharge of the residues overboard.

3.1.1 Oil residue (sludge) tank(s) shall be provided and:

- .1 shall be of adequate capacity, having regard to the type of machinery and length of voyage, to receive the oil residues (sludge) which cannot be dealt with otherwise in accordance with the requirements of this Annex; (MARPOL, Reg. I/12.3.1)

IMO interpretation

- 1 *To assist Administrations in determining the adequate capacity of oil residue (sludge) tanks, the following criteria may be used as guidance. These criteria should not be construed as determining the amount of oily residues which will be produced by the machinery installation in a given period of time. The capacity of oil residue (sludge) tanks may, however, be calculated upon any other reasonable assumptions. (...)*

(...)

- .3 *For ships which carry ballast water in fuel oil tanks, the minimum oil residue (sludge) tank capacity (V_2) should be calculated by the following formula:*

$$V_2 = V_1 + K_2B \quad (m^3) \text{ where:}$$

V_1 = oil residue (sludge) tank capacity (...) in m^3 ;

Note:

Tank capacity V_1 – see .4 or .5 below as appropriate.

K_2 = 0.01 for heavy fuel oil bunker tanks, or 0.005 for diesel oil bunker tanks; and

B = capacity of water ballast tanks which can also be used to carry oil fuel (tonnes).

- .4 *For ships which do not carry ballast water in fuel oil tanks, the minimum oil residue (sludge) tank capacity (V_1) should be calculated by the following formula:*

$$V_1 = K_1CD \quad (m^3) \text{ where:}$$

K_1 = 0.015 for ships where heavy fuel oil is purified for main engine use or 0.005 for ships using diesel oil or heavy fuel oil which does not require purification before use;

C = daily fuel oil consumption (m^3); and

D = maximum period of voyage between ports where oil residue (sludge) can be discharged ashore (days). In the absence of precise data a figure of 30 days should be used.

- .5 *For ships (...) which are fitted with homogenizers, oil residue (sludge) incinerators or other recognized means on board for the control of oil residue (sludge), the minimum oil residue (sludge) tank capacity should be:*

.5.1 50% of the value calculated according to item .4 above; or

.5.2 1 m^3 for ships of 400 gross tonnage and above but less than 4,000 gross tonnage or 2 m^3 for ships of 4,000 gross tonnage and above; whichever is the greater.

- 2 *Administrations should establish that (...) adequate tank capacity, which may include the oil residue (sludge) tank(s) (...), is available also for leakage, drain and waste oils from the machinery installations. (...)* (MEPC.1/Circ.867)

- .2 shall be provided with a designated pump that is capable of taking suction from the oil residue (sludge) tank(s) for disposal of oil residue (sludge) by means as described in 3.1.4 (regulation 12.2); (MARPOL, Reg. I/12.3.2)

IMO interpretation

A designated pump should be interpreted as any pump used for the disposal of oil residue (sludge) through the standard discharge connection referred to in regulation 13, or any pump used to transfer oil residue (sludge) to any other approved means of disposal such as an incinerator, auxiliary boiler suitable for burning oil residues (sludge) or other acceptable means (...). (MEPC.1/Circ.867)

- .3** shall have no discharge connections to the bilge system, oily bilge water holding tank(s), tank top or oily water separators, except that:
- .1** the tank(s) may be fitted with drains, with manually operated self-closing valves and arrangements for subsequent visual monitoring of the settled water, that lead to an oily bilge water holding tank or bilge well, or an alternative arrangement, provided such arrangement does not connect directly to the bilge discharge piping system; and
 - .2** the sludge tank discharge piping and bilge-water piping may be connected to a common piping leading to the standard discharge connection referred to in 3.2.1 (regulation 13); the connection of both systems to the possible common piping leading to the standard discharge connection referred to in 3.2.1 (regulation 13) shall not allow for the transfer of sludge to the bilge system; (MARPOL, Reg. I/12.3.3)

IMO interpretation

A screw-down non-return valve, arranged in lines connecting to common piping leading to the standard discharge connection required by 3.2.1 (regulation 13), provides an acceptable means to prevent oil residue (sludge) from being transferred or discharged to the bilge system, oily bilge water holding tank(s), tank top or oily water separators. (MEPC.1/Circ.867)

- .4** shall not be arranged with any piping that has direct connection overboard, other than the standard discharge connection referred to in 3.2.1 (regulation 13); and (MARPOL, Reg. I/12.3.4)
- .5** shall be designed and constructed so as to facilitate their cleaning and the discharge of residues to reception facilities. (MARPOL, Reg. I/12.3.5)

IMO interpretation

To assist Administrations in determining the adequacy of the design and construction of oil residue (sludge) tanks to facilitate their cleaning and the discharge of residues to reception facilities, the following guidance is provided (...):

- .1** sufficient man-holes should be provided such that, taking into consideration the internal structure of the oil residue (sludge) tanks, all parts of the tank can be reached to facilitate cleaning;
- .2** oil residue (sludge) tanks in ships operating with heavy oil, that needs to be purified for use, should be fitted with adequate heating arrangements or other suitable means to facilitate the pump ability and discharge of the tank content;
- .3** the oil residue (sludge) tank should be provided with a designated pump for the discharge of the tank content to reception facilities. The pump should be of a suitable type, capacity and discharge head, having regard to the characteristics of the liquid being pumped and the size and position of tank(s) and the overall discharge time; and
- .4** where any oil residue (sludge) tank (i.e. oil residue (sludge) service tank ¹⁾ that directly supplies oil residue (sludge) to the means of the disposal of oil residues (sludge) prescribed in paragraph 3.2 of the Supplement to IOPP Certificate Form A or B is equipped with suitable means for drainage, the requirements in subparagraph .3 above may not be applied to the oil residue (sludge) tank.

¹ "Oil residue (Sludge) Service tank" means a tank for preparation of oil residue (sludge) for incineration as defined in paragraph 5.3.3 of the appendix to the annex to the 2008 Revised Guidelines for systems for handling oily wastes in machinery spaces of ships incorporating guidance notes for an integrated bilge water treatment system (IBTS) (MEPC.1/Circ.642), as amended by MEPC.1/Circ.676 and MEPC.1/Circ.760. (MEPC.1/Circ.867)

3.1.2 Where the main and auxiliary engines require a complete change of the lubricating oil at sea, exhausted oil tanks shall be provided with capacity V_3 determined as 1.5 m³ for each 1000 kW engine rated power.

3.1.3 Oil residues tanks whose content may be incidentally discharged overboard through vent pipes shall be fitted with the alarm of maximum allowable tank filling limit.

3.1.4 Oil residue (sludge) may be disposed of directly from the oil residue (sludge) tank(s) to reception facilities through the standard discharge connection referred to in 3.2.1 (regulation 13), or to any other approved means of disposal of oil residue (sludge), such as an incinerator, auxiliary boiler suitable for burning oil residues (sludge) or other acceptable means (...). (MARPOL, Reg. I/12.2)

3.2 Standard discharge connection

3.2.1 To enable pipes of reception facilities to be connected with the ship's discharge pipeline for residues from machinery bilges and from oil residue (sludge) tanks, both lines shall be fitted with a standard discharge connection in accordance with the following table:

Standard dimensions of flanges for discharge connections

Description	Dimension
Outside diameter	215 mm
Inner diameter	According to pipe outside diameter
Bolt circle diameter	183 mm
Slots in flange	6 holes 22 mm in diameter equidistantly placed on a bolt circle of the above diameter, slotted to the flange periphery. The slot width to be 22 mm
Flange thickness	20 mm
Bolts and nuts:	6, each of 20 mm in diameter and of quantity, diameter suitable length
The flange is designed to accept pipes up to a maximum internal diameter of 125 mm and shall be of steel or other equivalent material having a flat face. This flange, together with a gasket of oil-proof material, shall be suitable for a service pressure of 600 kPa.	

(MARPOL, Reg. I/13)

3.2.2 The standard discharge connection shall be installed on the deck accessible from both sides of the ship and so located as to enable easy connection of the reception hose. The discharge connection shall be fitted with a blank flange and nameplate marked "Oil residues".

CHAPTER 4

4 BALLAST AND ANTI-HEELING SYSTEMS

4.1 Pumps and tanks

4.1.1 At least two pumps shall be provided for filling and emptying the ballast tanks.

It is recommended to determine the capacity of the ballast pump on the assumption that when pumping out water from the largest ballast tank, the velocity of the water flow is not less than 2 m/s, with the suction pipe diameter determined by the formula provided in 4.2.1.

4.1.2 General service pumps, as well as fire or sanitary pumps may be used as ballast pumps. As a stand-by ballast pump, bilge pump may be used or, taking into account reservations specified in 4.1.3, stand-by cooling water pump. Fire pumps may be used, provided that the requirements specified in *Part V*, 3.2.2.1 are fulfilled.

4.1.3 Where ballast tanks are also used for carriage of oil fuel, the stand-by cooling water pump or a fire pump shall not be used for ballasting purposes, nor may the ballast pump be used as a stand-by cooling or fire pump.

For the use of ballast pumps as independent power bilge pumps and the arrangement of the bilge and ballast pumping systems – see 2.3.1.2 and 2.3.1.8 respectively.

4.1.4 Pumps used for taking ballast water from the double bottom tanks shall be of self-priming type.

4.1.5 Water ballast should not in general be carried in tanks intended for oil fuel. In ships in which it is not practicable to avoid putting water in oil fuel tanks, oily-water separating equipment to the satisfaction of the Administration shall be fitted, or other alternative means, such as discharge to shore facilities, acceptable to the Administration shall be provided for disposing of the oily-water ballast. (SOLAS Reg. II-1/20.2)

Note:

For the oily-water separating equipment necessary to discharge into the sea of ballast water retained in fuel oil tanks – see 2.4.1.14.2.

The provisions of this regulation are without prejudice to the provisions of the *International Convention for the Prevention of Pollution from Ships* in force. (SOLAS Reg. II-1/20.3)

4.1.6 Except as provided in 4.1.7 (paragraph 2 of this regulation), in ships (...) of 4,000 gross tonnage and above other than oil tankers, and in oil tankers (...) of 150 gross tonnage and above, no ballast water shall be carried in any oil fuel tank. (MARPOL, Reg. I/16.1)

4.1.7 Where the need to carry large quantities of oil fuel render it necessary to carry ballast water which is not a clean ballast in any oil fuel tank, such ballast water shall be discharged to reception facilities or into the sea in compliance with regulation 15 of this Annex using the equipment specified in 2.4.1.14.2 (regulation 14.2 of this Annex) (...). (MARPOL, Reg. I/16.2)

Note:

Regulation 15 is an operational requirement not repeated in these *Rules*.

IMO interpretation

23.1 Large quantities of oil fuel

23.1.1 The phrase "large quantities of oil fuel" in 4.1.7 (regulation 16.2) refers to ships which are required to stay at sea for extended periods because of the particular nature of their operation and trade. Under the circumstances considered

these ships would be required to fill their empty oil fuel tanks with water ballast in order to maintain sufficient stability and safe navigation conditions.

23.1.2 Such ships may include inter alia certain large fishing vessels or ocean going tugs. Certain other types of ships which for reasons of safety, such as stability, may be required to carry ballast in oil fuel tanks may also be included in this category. (MEPC 52/24/Add.1 – Annex 3)

4.1.8 All ships other than those subject to 4.1.6 (paragraphs 1 (...) of this regulation) shall comply with the provisions of those paragraphs as far as is reasonable and practicable. (MARPOL, Reg. I/16.4)

IMO interpretation

24 Application of 4.1.8 (regulation 16.4)

4 When the separation of oil fuel tanks and water ballast tanks is unreasonable or impracticable for ships covered by 4.1.8 (regulation 16.4), ballast water may be carried in oil fuel tanks, provided that such ballast water is discharged into the sea in compliance with regulations 15.2, 15.3, 15.5 and 15.6 or into reception facilities in compliance with regulation 15.9. (MEPC 52/24/Add.1 – Annex 3)

Note:

Regulations 15.2, 15.3, 15.5, 15.6 and 15.9 are operational requirements not repeated in these Rules.

4.2 Pipe diameters

4.2.1 Internal diameters, d_w of suction branches of the ballast pipes for particular tanks shall not be less than those determined in accordance with the following formula:

$$d_w = 18\sqrt[3]{V} \text{ [mm]}$$

where:

V – volume of the ballast tank, [m³].

The actual diameter may have the nearest standard size.

4.2.2 The internal diameter of the ballast main shall not be less than the maximum diameter of suction branch, determined in accordance with the above formula.

4.3 Arrangement of pipes and connections

4.3.1 Ballast water intakes and discharges shall comply with the requirements of 1.15.

4.3.2 Arrangement of the suction branches shall ensure the discharge of water from every ballast tank when the ship is upright or inclined not more than 5°.

4.3.3 Ballast pipes passing through oil fuel tanks shall be led inside tight tunnels forming an integral part of the tank or made of seamless steel pipes permanently connected. Where it is impracticable to make permanent joints, flange joints with gaskets resistant to the effect of oil fuel may be permitted.

4.3.4 Ballast pipes shall not be led through cargo holds.

4.3.5 Gravity drains from topside ballast tanks shall comply with the applicable requirements of 2.2.

4.4 Anti-heeling arrangements

4.4.1 Where the ballast system is provided with anti-heeling arrangements (pipes or ducts connecting opposite tanks) valves on such pipes or ducts should be of a “normally closed” type and open only when the anti-heeling pumps operate.

4.4.2 Means shall be provided to keep to a minimum unsymmetrical flooding in case of ship damage.

Where it is necessary to correct large angles of heel, the means adopted shall, where practicable, be self-acting, but in any case where controls to equalization devices are provided they shall be operable from above the bulkhead deck of passenger ships and the freeboard deck of cargo ships. These fittings together with their controls shall be acceptable to the Administration*. Suitable information concerning the use of equalization devices shall be supplied to the master of the ship. (SOLAS Reg. II-1/7-2.5)

Reference is made to the *Revised recommendation on a standard method for evaluating cross-flooding arrangements*, adopted by the Organization by resolution MSC.362(92), as may be amended.

4.4.3 Tanks and compartments taking part in such equalization shall be fitted with air pipes or equivalent means of sufficient cross-section to ensure that the flow of water into the equalization compartments is not delayed. (SOLAS Reg. II-1/7-2.5.1)

4.5 Ballast water and sediments management systems

4.5.1 Basic requirements

4.5.1.1 In order to prevent the transfer of harmful aquatic organisms and pathogens in ballast water, ballast water systems including ballast water tanks and their internal structure shall be designed having regard to the recommendations contained in the *BWM Convention*, as well as in IMO Resolutions MEPC.149(55) and MEPC.209(63).

4.5.1.2 A ship (...) shall conduct ballast water management that at least meets the standard described in 4.5.2 (regulation D-2). (BWM, Reg. B-3.5)

4.5.1.3 Ships (...) should, without compromising safety or operational efficiency, be designed and constructed with a view to minimize the uptake and undesirable entrapment of Sediments, facilitate removal of Sediments, and provide safe access to allow for Sediment removal and sampling, taking into account guidelines developed by the Organization. (...) (BWM, Reg. B-5.2)

Note:

Applicable guidelines are contained in IMO resolutions MEPC.149(55) and MEPC.209(63).

4.5.2 Ballast water performance standard

4.5.2.1 Ships conducting ballast water management in accordance with regulation D-2 shall discharge less than 10 viable organisms per cubic metre greater than or equal to 50 micrometres in minimum dimension and less than 10 viable organisms per millilitre less than 50 micrometres in minimum dimension and greater than or equal to 10 micrometres in minimum dimension; and discharge of the indicator microbes shall not exceed the specified concentrations described in paragraph 2. (BWM, Reg. D-2.1)

4.5.2.2 Indicator microbes, as a human health standard, shall include:

- .1** Toxicogenic *Vibrio cholerae* (O1 and O139) with less than 1 colony forming unit (cfu) per 100 millilitres or less than 1 cfu per 1 gram (wet weight) zooplankton samples;
- .2** *Escherichia coli* less than 250 cfu per 100 millilitres;
- .3** Intestinal Enterococci less than 100 cfu per 100 millilitres. (BWM, Reg. D-2.2)

4.5.3 Approval of ballast water management systems

4.5.3.1 Except as specified in 4.5.3.2 (paragraph 2), ballast water management systems used to comply with this Convention shall be approved by the Administration as follows:

- .1 ballast water management systems (...) shall be approved in accordance with the *BWMS Code*, as may be amended; (...) (BWM, Reg. D-3.1)

Note:

BWMS Code is the *Code for Approval of Ballast Water Management Systems* adopted by IMO resolution MEPC.300(72).

4.5.3.2 Ballast Water Management systems which make use of Active Substances or preparations containing one or more Active Substances to comply with this Convention shall be approved by the Organization, based on a procedure developed by the Organization. This procedure shall describe the approval and withdrawal of approval of Active Substances and their proposed manner of application. At withdrawal of approval, the use of the relevant Active Substance or Substances shall be prohibited within 1 year after the date of such withdrawal. (BWM, Reg. D-3.2)

Note:

Applicable procedure for approval is provided in IMO resolution MEPC.169(57).

4.5.3.3 Ballast Water Management systems used to comply with this Convention must be safe in terms of the ship, its equipment and the crew. (BWM, Reg. D-3.3)

4.5.4 Installation of ballast water management systems

IACS UR M74

4.5.4.1 Application (1.)

In addition to the requirements contained in BWM Convention (2004), the following requirements are applied to the installation of Ballast Water Management Systems.

This UR is not applied to ship's ballast water systems including piping valves, pumps, etc. where the BWMS is not fitted.

This UR is to be read in conjunction with IACS UR F45 – Installation of BWMS on-board ships (see *Part V*, 8.6).

4.5.4.2 Definitions (2.)

4.5.4.2.1 Ballast Water Management System (hereinafter referred to as 'BWMS') means any system which processes ballast water such that it meets or exceeds the Ballast Water Performance Standard in Regulation D-2 of the BWM Convention. The BWMS includes ballast water equipment, all associated piping arrangements as specified by the manufacturer, control and monitoring equipment and sampling facilities. The categorization of BWMS technologies is given in Table 1. Applicability of the requirements for each BWMS technology is in accordance with Table 2. **(2.1)**

Table 1 – Categorization of BWMS technologies

BWMS's Technology category (informative Annex II should be referred to) →		1	2	3a	3b	3c	4	5	6	7a	7b	8	
		Characteristics ↓											
Des-infection when ballasting	Making use of active substance		X			In-tank technology: No treatment when ballasting or de-ballasting	X	X	X	X	X		
	Full flow of ballast water is passing through the BWMS	X	X	X	X		X					X	
	Only a small part of ballast water is passing through the BWMS to generate the active substance								X				
After-treatment when de-ballasting	Full flow of ballast water is passing through the BWMS	X				In-tank technology: No treatment when ballasting or de-ballasting					X		
	Injection of neutralizer						X	X	X	X	X		
	Not required by the Type Approval Certificate issued by the Administration		X	X									
Examples of dangerous gas as defined in UR M74 §2.3			(1)	O ₂ N ₂	CO ₂ CO		H ₂ Cl ₂	H ₂ Cl ₂	(1)	O ₂ O ₃ N ₂		O ₂ N ₂	
Note: (1) To be investigated on a case by case basis based on the result of the IMO (GESAMP) MEPC report for Basic and Final approval in accordance with the G9 Guideline. (2) In-line side stream electrolysis may also be applied in-tank in circulation mode (no treatment when ballasting or de-ballasting)													

Taking into consideration future developments of BWMS technologies, some additional technologies may be considered in this Table 1 by identifying their characteristics in the same manner as for the above BWMS categories 1, 2, 3a, 3b, 3c, 4, 5, 6, 7a, 7b and 8.

4.5.4.2.2 Cargo area of tankers is defined in:

- for tankers to which regulation 1.6.1 of SOLAS Chapter II-2 as amended by IMO resolutions up to MSC.421(98) (hereinafter the same) applies, regulation 3.6 of SOLAS Chapter II-2 (see 1.2.11);
- for chemical tankers, Paragraph 1.3.6 of the *IBC Code* as amended by IMO resolutions up to MSC.460(101);
- for gas carriers, Paragraph 1.2.7 of the *IGC Code* as amended by IMO resolutions up to MSC.441(99); and
- for offshore support vessels, Paragraph 1.3.1 of the IMO Resolution A.673(16) as amended by Resolution MSC.236(82) or Paragraph 1.2.7 of the IMO Resolution A.1122(30), as applicable. (2.2)

Table 2 - Applicability of the requirements for each BWMS technology

	1	2	3a	3b	3c	4	5	6	7a	7b	8
BWMS's Technology category (informative Annex II should be referred to) →	In-line UV or UV + Advanced Oxidation Technology (AOT) or UV + TiO ₂ or UV + Plasma	In-line Flocculation	In-line membrane separation and de-oxygenation (injection of N ₂ from N ₂ Generator)	In-line de-oxygenation (injection of Inert Gas from Inert Gas Generator)	In-tank de-oxygenation with Inert Gas Generator	In-line full flow electrolysis	In-line side-stream electrolysis	In-line (stored) chemical injection	In-line side-stream ozone injection without gas/liquid separation tank and without discharge treatment tank	In-line side-stream ozone injection with gas/liquid separation tank and without Discharge water treatment tank	In-tank pasteurization and de-oxygenation with N ₂ generator
4.5.4 (UR M74) requirement ↓											
4.5.4.1 and 4.5.4.2 (1. and 2.)	X	X	X	X	X	X	X	X	X	X	X
4.5.4.3.1.1 to 4.5.4.3.1.4 (3.1.1 to 3.1.4)	X	X	X	X	X	X	X	X	X	X	X
4.5.4.3.1.5 (3.1.5)			X	X	X						X
4.5.4.3.1.6 (3.1.6)	X	X	X	X	X	X	X	X	X	X	X
4.5.4.3.1.7 (3.1.7)			X	X	X						X
4.5.4.3.1.8 (3.1.8)				X						X	
4.5.4.3.1.9 (3.1.9)	X	X	X	X	X	X	X	X	X	X	X
4.5.4.3.2.1.1 (3.2.1.1)				X	X				X	X	
4.5.4.3.2.1.2 (3.2.1.2)						X	X	X			
4.5.4.3.2.2 (3.2.2)	X	X	X	X		X	X	X	X	X	
4.5.4.3.2.3 (3.2.3)	X	X	X	X	X	X	X	X	X	X	X
4.5.4.3.2.4 (3.2.4)	X	X	X	X		X	X	X	X	X	
4.5.4.3.3.1.1 (3.3.1.1)		X	X			X	X	X	X	X	X
4.5.4.3.3.1.2 (3.3.1.2)			X	X	X				X	X	X
4.5.4.3.3.1.3 (3.3.1.3)									X	X	
4.5.4.3.3.1.4 (3.3.1.4)						X	X	X	X	X	
4.5.4.3.3.1.5 (3.3.1.5)						X	X	X			
4.5.4.3.3.1.6 (3.3.1.6)			X	X	X				X	X	X
4.5.4.3.3.2.1 to 4.5.4.3.3.2.4 (3.3.2.1 to 3.3.2.4)		X	X	X	X	X	X	X	X	X	X
4.5.4.3.3.2.5 (3.3.2.5)			X			X	X	X	X	X	X
4.5.4.3.3.2.6 (3.3.2.6)			X						X	X	X
4.5.4.3.3.2.7 (3.3.2.7)			X			X	X	X	X	X	X
4.5.4.3.3.3 (3.3.3)		X				X	X	X	X	X	
4.5.4.3.3.4 (3.3.4)						X	X	X	X	X	

4.5.4.2.3 Dangerous gas means any gas which may develop an explosive and/or toxic atmosphere being hazardous to the crew and/or the ship due to flammability, explosivity, toxicity,

asphyxiation, corrosivity or reactivity and for which due consideration of the hazards is required, e.g. hydrogen (H₂), hydrocarbon gas, oxygen (O₂), carbon dioxide (CO₂), carbon monoxide (CO), ozone (O₃), chlorine (Cl₂) and chlorine dioxide (ClO₂), etc. **(2.3)**

4.5.4.2.4 Dangerous liquid means any liquid that is identified as hazardous in the Material Safety Data Sheet or other documentation relating to this liquid. **(2.4)**

4.5.4.2.5 Hazardous area is defined in IEC 60092-502:1999 and means an area in which an explosive gas atmosphere is or may be expected to be present, in quantities such as to require special precautions for the construction, installation and use of electrical apparatus. When a gas atmosphere is present, the following hazards may also be present: toxicity, asphyxiation, corrosivity and reactivity. **(2.5)**

4.5.4.2.6 Non-hazardous area means an area which is not a hazardous area as defined in above 2.5. **(2.6)**

4.5.4.3 Installation (3.)

4.5.4.3.1 General requirements (3.1)

4.5.4.3.1.1 All valves, piping fittings and flanges are to comply with the relevant requirements of 1.6 and 1.7 (IACS UR P2 and P4). In addition, special consideration can be given to the material used for this service with the agreement of Society. **(3.1.1)**

4.5.4.3.1.2 The BWMS is to be provided with by-pass or override arrangement to effectively isolate it from any essential ship system to which it is connected. For new installation or retrofit to existing ships, under normal operating conditions of ballasting and de-ballasting given in the Ballast Water Management Plan (BWMP) the adequacy of the generating plant capacity installed on the vessel is to be demonstrated by an electrical load analysis.

For retrofit installation to existing ships, a revised electrical load analysis with preferential trips of non-essential services can be accepted. **(3.1.2)**

4.5.4.3.1.3 The BWMS is to be operated in accordance with the requirements specified in the Type Approval Certificate (TAC) issued by the Flag Administration. BWMS should be operated within its Treatment Rated Capacity (TRC) as per the TAC. This may require limiting of ship's ballast pump flowrates.

The arrangement of the bypasses or overrides of the BWMS is to be consistent with the approved Operation Maintenance and Safety Manual by the Flag Administration's Type Approval.

In case the maximum capacity of the ballast pump(s) exceeds the maximum treatment rated Capacity (TRC) of the BWMS specified in the TAC issued by the Flag Administration, there should be a limitation on the BWMP giving a maximum allowable flow rate for operating the ballast pump(s) that shall not exceed the maximum TRC of the BWMS. **(3.1.3)**

4.5.4.3.1.4 BWMS should be subject to design review by the Classification Society to verify the compliance of the BWMS's manufacturer package with the Classification Rules. Manufacturers of the BWMS may apply for this design review at the type approval process.

In general, monitoring functions of BWMS belongs to system category I under the application of the *Publication 9/P – Requirements for Computer Based Systems* (UR E22 Rev.2). However, in case a by-pass valve is integrated in the valve remote control system, the by-pass valve belongs to the system category II Ballast transfer remote control system.

The BWMS's components are required to be inspected and certified by the Classification Society at the manufactory (Society Certificate (SC) as defined in *Publication 4/P – I.C. Engines and Engine Components – Survey and Certification* (UR M72)) including pressure vessels, piping class I or II, filters, switchboards, etc. **(3.1.4)**

4.5.4.3.1.5 Where a vacuum or overpressure may occur in the ballast piping or in the ballast tanks due to the height difference or injection of inert gas or nitrogen (N₂), a suitable protection device is to be provided, (i.e. P/V valves, P/V breakers, P/V breather valves or pressure safety relief valve or high/low pressure alarms).

The pressure and vacuum settings of the protection device should not exceed the design pressure of the ballast piping (BWMS categories 3a and 3b) or ballast tank (BWMS categories 3a, 3b and 3c), as relevant.

For BWMS categories 3a, 3b and 3c, the inert gas or nitrogen product enriched air from the inert gas system and from the protection devices installed on the ballast tanks (i.e. P/V valves, P/V breakers or P/V breather valves) are to be discharged to a safe location^{*(1) & (2)} on the open deck.

Footnotes **safe location**^{*(1)} and **safe location**^{*(2)}

Safe location needs to address the specific types of discharges separately.

Signboards or similar warnings at the discharge areas are to be provided.

Safe location^{*(1)} inert gas or nitrogen product enriched air from:

- in-line (categories 3a and 3b) and in-tank (categories 3c and 8) de-oxygenation BWMS: the protection devices installed on the ballast tanks, nitrogen or inert gas generators, nitrogen buffer tank (if any); or
- in-line ozone injection BWMS (categories 7a and 7b): the oxygen generator;

safe locations on the open deck are:

- not within 3 m of areas traversed by personnel; and
- not within 6 m of air intakes for machinery (engines and boilers) and all ventilation inlets/outlets.

Safe location^{*(2)} oxygen-enriched air from:

- in-line and in-tank de-oxygenation BWMS (categories 3a and 8): the nitrogen generator; or
- in-line ozone injection BWMS (categories 7a and 7b): the protection devices or vents from oxygen generator, compressed oxygen vessel, the ozone generator and ozone destructor devices;

safe locations on the open deck are:

- outside of hazardous area;
- not within 3 m of any source of ignition and from deck machinery, which may include anchor windlass and chain locker openings, and equipment which may constitute an ignition hazard;
- not within 3 m of areas traversed by personnel; and
- not within 6 m of air intakes for machinery (engines and boilers) and all ventilation inlets.

When the concerned ballast tanks are hazardous areas, an extension of hazardous area is to be considered at the outlet of the protection devices: with reference to IEC 60092-502:1999 §4.2.2.9 the areas on open deck, or semi-enclosed spaces on open deck, within 1.5 m of their outlets are to be categorized hazardous zone 1 and with reference to IEC 60092-502:1999 §4.2.3.1, an additional 1.5 m surrounding the 1.5 m hazardous zone 1 is to be categorized hazardous zone 2. Any source of ignition such as anchor windlass or opening into chain locker should be located outside the hazardous areas.

Where products covered by IEC 60092-502:1999 are stored on-board or generated during operation of the BWMS, the requirements of this standard shall be followed in order to:

- Define hazardous areas and acceptable electrical equipment, and
- Design ventilation systems. **(3.1.5)**

4.5.4.3.1.6 Electric and electronic components are not to be installed in a hazardous area unless they are of certified safe type for use in the area. Cable penetrations of decks and bulkheads are to be sealed when a pressure difference between the areas is to be maintained. **(3.1.6)**

4.5.4.3.1.7 Inert gas systems installed for de-oxygenation BWMS (categories 3a, 3b, 3c and 8) are to be designed in accordance with the following requirements: **(3.1.7)**

4.5.4.3.1.7.1 *FSS Code* Ch. 15 requirements

- 2.1.2, 2.1.3
- 2.2.1.3, 2.2.1.4, 2.2.2.1, 2.2.2.2, 2.2.2.3, 2.2.2.6, 2.2.4.1, 2.2.4.2, 2.2.4.3, 2.2.4.4, 2.2.4.5 except 2.2.4.5.1.3 and 2.2.4.5.3
- 2.3.1.1.2, 2.3.1.2, 2.3.1.4.2, 2.3.1.5, 2.3.1.6, 2.3.2 except 2.3.2.2.1
- 2.4.1.3, 2.4.1.4 and 2.4.2
- For inert gas systems installed for in-tank de-oxygenation BWMS (category 8): 2.2.3.1, 2.2.3.2 except 2.2.3.2.6, 2.2.3.2.7 and 2.2.3.2.10

In general, when applying *FSS Code* Ch.15 requirements to inert-gas based BWMS, the following modifications are to be considered:

- The terms "cargo tank" and "cargo piping" are to be replaced by "ballast water tank" or "ballast water piping" as relevant.
- The term "cargo control room" is to be replaced by "BWMS control station" as relevant
- Requirements for slop tanks on combination carriers are to be disregarded
- When applying *FSS Code*/15.2.2.4.5.1.1, the acceptable oxygen content is to be specified by the manufacturer, 5% oxygen content need not necessarily be applied. **(3.1.7.1)**

4.5.4.3.1.7.2 *Part V* requirements 11.6.6.2.1.1 and 11.6.6.4.3 (IACS UR F20 requirements F20.1.1.1, F20.1.1.3, F20.3.1, F20.3.3, F20.3.7, F20.3.8, F20.4.4, F20.4.5 and F20.4.6) In applying F20.4.6, the terms "cargo tanks" and "cargo piping" are to be understood as "ballast tanks" and "ballast piping" respectively. For de-oxygenation BWMS (categories 3a, 3b, 3c and 8), the requirements in 4.5.4.3.1.7.1 (3.1.7.1) prevail. **(3.1.7.2)**

4.5.4.3.1.8 When cavitation is the BWMS treatment process (for example by use of pressure vacuum reactor working in combination with a vertical ballast water drop line) or part of the BWMS treatment process (for example by use of "smart pipe" or "special pipe" in BWMS category 7b or by use of "venturi pipe" in BWMS technology 3b) or by use other means, the design and the wall thickness or grade of materials or inside coating or surface treatment of the part of the piping where the cavitation is taking place is to be specifically considered. **(3.1.8)**

4.5.4.3.1.9 When it is required to have an automatic shutdown of the BWMS for safety reasons, this must be initiated by a safety system independent of the BWM control system. **(3.1.9)**

4.5.4.3.2 **Additional requirements for tankers: (3.2)**

4.5.4.3.2.1 Hazardous area classification is to be in accordance with IEC 60092-502:1999 with due consideration of *Part VIII*, 22.5.3 (IACS UI SC274).

- .1** BWMS using ozone generators (categories 7a and 7b) and de-oxygenation BWMS using inert gas generator by treated flue gas from main or auxiliary boilers or gas from an oil or gas-fired gas generator (categories 3b and 3c) are to be located outside the cargo area in accordance with *FSS Code* Ch. 15 §2.3.1.1.2.

Note: this requirement does not apply to inert gas generators for which *FSS Code* Ch. 15/2.4.1 and IACS UR F20.3 and F20.4 apply.

- .2** In-line full flow electrolysis BWMS (category 4), in-line side-stream electrolysis BWMS (category 5) and in-line injection BWMS using chemical which is stored onboard (category 6) can be located inside the hazardous areas with due consideration of the requirement of 3.1.6 but should not be located inside the cargo pump room unless it is demonstrated by the BWMS manufacturer that the additional hazards that could be expected from dangerous liquids and dangerous gases stored or evolved from the BWMS (for example H₂ generation):
- do not lead to an upgrade of the hazardous area categorization of the cargo pump room,
 - are not reactive with the cargo vapours expected to be present in the cargo pump room,
 - are not reactive with the fire-extinguishing medium provided inside the cargo pump room,
 - are not impacting the performance of the existing fire-fighting systems provided inside the cargo pump room, and
 - are not introducing additional hazards inside the cargo pump room such as toxicity hazards that would not have been prior addressed by suitable counter measures.
- (3.2.1)**

Notes:

- 1) In-line full flow electrolysis BWMS (category 4) could be accepted in cargo compressor rooms of liquefied gas carriers and inside cargo pump rooms of oil tankers or chemical tankers if that cargo pump room is located above the cargo tank deck.
- 2) For submerged cargo pumps, the room containing the hydraulic power unit or electric motors is not to be considered as the “cargo pump room”.
- 3) Ballast pump rooms and other pump rooms not containing the cargo pumps are not to be considered as the “cargo pump room”.

4.5.4.3.2.2 In general, two independent BWMS should be required i.e. one for ballast tanks located within the cargo area and the other one for ballast tanks located outside cargo area. Specific arrangements where only one single In-line BWMS (categories 1, 2, 3a, 3b, 4, 5, 6, 7a and 7b) could be accepted are given in Annex I. **(3.2.2)**

Note: When the Fore Peak Tank is ballasted with the piping system serving the other ballast tanks within the cargo area in accordance with IACS UR F44, the ballast water of the Fore Peak tank is to be processed by the BWMS processing the ballast water of the other ballast tanks within the cargo area.

4.5.4.3.2.3 Isolation between ballast piping serving the ballast tanks inside and outside of the cargo area is to be in accordance with the following requirements: **(3.2.3)**

4.5.4.3.2.3.1 Interconnection in between the ballast piping serving the ballast tanks located within the cargo area and the ballast piping serving the ballast tanks located outside the cargo area may be accepted if appropriate isolation arrangement is provided in accordance with Annex I is applied.

Note 1: The means of appropriate isolation described in 4.5.4.3.2.3.1 (Paragraph 3.2.3.1) is necessary for the interconnection specified in said Paragraph regardless of the diameter of the piping.

Note 2: As indicated in Annex I, the means of appropriate isolation described in 4.5.4.3.2.3.1 (Paragraph 3.2.3.1) is necessary for the interconnection specified in said Paragraph in the case of the active substance piping such as N₂ gas piping, inert gas piping, neutralizer piping, fresh water piping for filter cleaning, compressed air piping for remaining water purge and sea water piping for adjusting the salinity etc. At the discretion of the Classification Society and for active substance piping and neutralizer piping (both up to 2 inches) only, alternative isolation arrangements, provided

preferably on the open deck, offering enhanced safety and gastightness may be considered for penetration of the bulkhead separating the non-hazardous machinery space from a hazardous area (such as the cargo pump room) at as high an elevation in the machinery space as possible, preferably, just below the main deck. The arrangements are to provide suitable protection measures in addressing the pollution hazards and safety concerns due to the potential migration of hydrocarbon or flammable or toxic liquids or vapours from the hazardous areas.

Note 3: The means of appropriate isolation described in this 4.5.4.3.2.3.1 (Paragraph 3.2.3.1) for the interconnection specified in said Paragraph need not be applied to the sampling lines described in 4.5.4.3.2.4 (Paragraph 3.2.4).

The means of appropriate isolation is to be one of the following:

- .1 Two non-return valves with positive means of closing in series with a spool piece (also mentioned “means of dis-connection” in Annex I), or

Note: As an alternative to positive means of closure, an additional valve having such means of closure may be provided between the non-return valve and the spool piece.

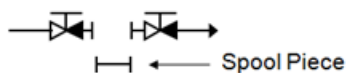

- .2 Two non-return valves with positive means of closing in series with a liquid seal at least 1.5 m in depth, or

Note 1: As an alternative to positive means of closure, an additional valve having such means of closure may be provided between the non-return valve and the liquid seal.

Note 2: For ships operating in cold weather conditions, freeze protection should be provided in the water seal. A portable heating system can be accepted for this purpose.

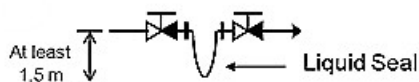

- .3 Automatic double block and bleed valves and a non-return valve with positive means of closing. (3.2.3.1)

Note: As an alternative to positive means of closure, an additional valve having such means of closure may be provided after the non-return valve.

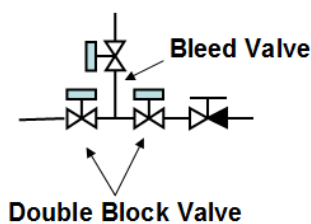

4.5.4.3.2.3.2 The above-mentioned means of appropriate isolation is to be provided on the open deck in the cargo area. (3.2.3.2)

Note: When the Fore Peak Tank is ballasted with the piping system serving the other ballast tanks within the cargo area in accordance with IACS UR F44, the means of appropriate isolation described in Paragraphs 3.2.3.1 and 3.2.3.2 is not required in between the Fore Peak Tank and the common ballast water piping serving the other ballast water tanks within the cargo area.

4.5.4.3.2.4 Sampling lines which are connected to the ballast water piping system serving the tanks in the cargo area and provided for the purpose of the following:

- for any BWMS: ballast water sampling required by the G2 Guideline of the BWM Convention (2004), or
- for BWMS technologies categories 4, 5, 6, 7a and 7b: total residual oxidant (TRO) analysis in closed loop system;

are not to be led into a non-hazardous enclosed space outside the cargo area.

However, the sampling lines may lead into a non-hazardous enclosed space outside the cargo area provided the following requirements are fulfilled:

- .1 The sampling facility (for BWMS monitoring/control) is to be located within a gas tight enclosure (hereinafter, referred to as a 'cabinet'), and the following i) through iv) are to be complied.
 - i) In the cabinet, a stop valve is to be installed on each sampling line.
 - ii) Gas detection equipment is to be installed in the cabinet and the valves specified in i) above are to be automatically closed upon activation of the gas detection equipment.
 - iii) Audible and visual alarm signals are to be activated both locally and at the BWMS control station when the concentration of explosive gases reaches a pre-set value, which should not be higher than 30% of the lower flammable limit (LFL). Upon an activation of the alarm, all electrical power to the cabinet is to be automatically disconnected.

Note: when the electrical equipment is of a certified safety type, the automatic disconnection of power supply is not required.

 - iv) The cabinet is to be vented to a safe location in non-hazardous area on open deck and the vent is to be fitted with a flame arrester.
- .2 The standard internal diameter of sampling pipes is to be the minimum necessary in order to achieve the functional requirements of the sampling system.
- .3 The cabinet is to be installed as close as possible to the bulkhead facing the cargo area, and the sampling lines located outside the cargo area are to be routed on their shortest ways.
- .4 Stop valves are to be located in the non-hazardous enclosed space outside the cargo area, in both the suction and return lines close to the penetrations through the bulkhead facing the cargo area. A warning plate stating "Keep valve closed when not performing measurements" is to be posted near the valves. Furthermore, in order to prevent backflow, a water seal or equivalent arrangement is to be installed on the hazardous area side of the return pipe.
- .5 A stop valve is to be installed on the cargo area for each sampling line (i.e. both the suction and return lines).
- .6 The samples which are extracted from the ballast water piping system serving the tanks within the cargo area are not to be discharged to a tank located outside the cargo area and not to discharge to a piping line supplying the spaces located outside the cargo area. **(3.2.4)**

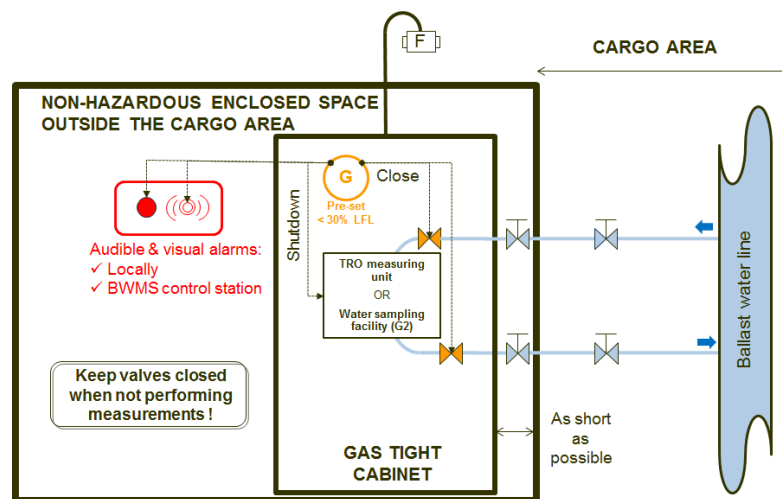

4.5.4.3.3 Special requirements for BWMS categories 2, 3a, 3b, 3c, 4, 5, 6, 7a, 7b and 8 generating dangerous gas or dealing with dangerous liquids. (3.3)

4.5.4.3.3.1 Where the operating principle of the BWMS involves the generation of a dangerous gas, the following requirements are to be satisfied:

- .1** Gas detection equipment is to be fitted in the spaces where dangerous gas could be present, and an audible and visual alarm is to be activated both locally and at the BWMS control station in the event of leakage.

The gas detectors should be located as close as possible to the BWMS components where the dangerous gas may accumulate.

For flammable gases and explosive atmosphere including but not limited to H₂, the construction, testing and performance of the gas detection devices is to be in accordance with IEC 60079-29-1:2016, IEC 60079-29-2:2015, IEC 60079-29-3:2014 and/or IEC 60079-29-4:2009, as applicable.

Where other hazards are considered like toxicity, asphyxiation, corrosive and reactivity hazards, a recognized standard acceptable to the Society is to be selected with due consideration of the specific gases to be detected and due consideration of the performance of the detection device with regards to the specific atmosphere where it is used.

- .2** In spaces where inert gas generator systems are fitted (BWMS categories 3b and 3c) or nitrogen generators are fitted (BWMS categories 3a and 8), at least two oxygen sensors shall be positioned at appropriate locations (as required by Paragraph 2.2.4.5.4 of Chapter 15 of the *FSS Code* as amended by IMO resolutions up to MSC.410(97)) to alarm when the oxygen level falls below 19%. The alarms shall be both audible and visual and shall be activated:

- inside the space;
- at the entry into the space; and
- inside the BWMS control station.

For BWMS categories 7a and 7b, at least two oxygen sensors shall be positioned at appropriate locations in the following spaces:

- spaces where ozone generators are fitted, or
- spaces where ozone destructors are fitted, or
- spaces where ozone piping is routed;

to alarm when the oxygen level raises above 23 %. The alarms shall be both audible and visual and shall be activated at the following locations:

- inside the space; and
- at the entry into the space; and
- inside the BWMS control station.

Automatic shut-down of the BWMS is to be arranged when the oxygen level raises above 25%. Audible and visual alarms independent from those specified in the preceding paragraph are to be activated prior to this shut-down.

- .3** For BWMS categories 7a and 7b, at least one ozone sensor shall be provided at the vicinity of the discharge outlet to the open deck from the ozone destructors addressed in Footnote *(4) to alarm when the ozone concentration level raises above 0.1 ppm. The alarms shall

be both audible and visual and shall be activated in the BWMS control room. In addition, at least two ozone sensors shall be positioned at appropriate location in the following spaces:

For ^{*(4)} refer to Footnotes to 4.5.4.3.3.2.3 (Paragraph 3.3.2.3)

- spaces where ozone generators are fitted, or
- spaces where ozone destructors are fitted, or
- spaces where ozone piping is routed;

to alarm when the ozone concentration level raises above 0.1 ppm. The alarms shall be both audible and visual and shall be activated at the following locations:

- inside the space;
- at the entry into the space; and
- inside the BWMS control station.

Automatic shut-down of the BWMS is to be arranged when the ozone concentration measured from one of the two sensors inside the space raises above 0.2 ppm.

- .4** Inside double walled spaces or pipe ducts constructed for the purpose of 4.5.4.3.3.2.1 (3.3.2.1) Note 1), sensors are to be provided for the detection of H₂ leakages (BWMS categories 4, 5 and 6 when relevant) or O₂ leakages (BWMS categories 7a and 7b) or O₃ leakages (BWMS categories 7a and 7b). The sensors are to activate an alarm at the high level settings and automatic shut-down of the BWMS at the high-high level settings described in above 4.5.4.3.3.1.1 to 4.5.4.3.3.1.3 (3.3.1.1 to 3.3.1.3).

Note: As an alternative to the sensor for the gas detection, monitored under-pressurization inside the double walled spaces or pipe ducts could be provided with an automatic alarm and shut-down of the BWMS in case of loss of the under-pressurization. The monitoring can be achieved either by monitoring the pressure inside the double walled spaces or pipe ducts or by monitoring the exhaust fan.

- .5** For in-line full flow electrolysis BWMS (category 4), in-line side-stream electrolysis BWMS (category 5) and in-line injection BWMS using chemical which is stored onboard (category 6): the hydrogen de-gas arrangement (when provided) is to be provided with redundant ventilation fans and redundant monitoring of the ventilation system.

In addition the ventilation fan shall be certified explosion proof (see *Part VII*, 5.3.2) and have spark arrestor to avoid ignition sources to enter the ventilation systems whereas remaining H₂ gas may be present in dangerous concentrations.

Audible and visual alarms and automatic shut-down of the BWMS are to be arranged for respectively high and high-high levels of H₂ concentration. The open end of the hydrogen by-product enriched gas relieving device is to be led to a safe location^{*(3)} on open deck.

For **safe location** ^{*(3)} refer to Footnotes to 4.5.4.3.3.2.3 (Paragraph 3.3.2.3)

- .6** The open end of inert gas or nitrogen gas enriched air (BWMS categories 3a, 3b, 3c and 8) or oxygen-enriched air (BWMS categories 3a, 7a, 7b and 8) are to be led to a safe location^{*(1)} & ⁽²⁾ on open deck. **(3.3.1)**

For **safe location**^{*(1)} and **safe location**^{*(2)} refer to Footnotes to 4.5.4.3.1.5 (Paragraph 3.1.5)

4.5.4.3.3.2 Where the piping is conveying active substances, by-products or neutralizers that are containing dangerous gas or dangerous liquids as defined respectively in 4.5.4.2.3 and 4.5.4.2.4 (2.3 and 2.4), the following requirements are to be satisfied:

Notes:

- 1) This requirement is applicable to the injection lines conveying the dangerous gas or dangerous liquids but not applicable to the ballast water lines where the dangerous gas or dangerous liquids are diluted.
- 2) The IMO reports issued during the basic and final approval procedures of the BWMS that make use of active substances (G9 Guideline) could be used for assessing the hazards that could be expected from the media conveyed by the BWMS piping.

- .1** Irrespective of design pressure and temperature, the piping is to be either of Class I (without special safeguard) or Class II (with special safeguard) as required by 1.6.2 Table 1 (IACS UR P2 Table 1). The selected materials, the testing of the material, the welding, the non-destructive tests of the welding, the type of connections, the hydrostatic tests and the pressure tests after assembly on-board are to be as required in 1.6 (IACS UR P2). Mechanical joints, where allowed, are to be selected in accordance with 1.6.7 Table 8 (IACS UR P2 Table 8).

Notes:

- 1) For piping class II with special safeguards conveying dangerous gas like hydrogen (H₂), oxygen (O₂) or ozone (O₃), the special safeguards are to be either double walled pipes or pipe duct.
- 2) For piping class II with special safeguards conveying dangerous liquids, other special safeguards could be considered like shielding, screening, etc.
- 3) Plastic pipes may be accepted after due assessment of the dangerous gas or dangerous liquids conveyed inside. When plastic pipes are accepted, the requirements of UR P4 apply.

- .2** The length of pipe and the number of connections are to be minimised.
- .3** Inside double walled space or pipe ducts constructed as the special safeguard for the purpose of 4.5.4.3.3.2.1 (3.3.2.1) Note 1) are to be equipped with mechanical exhaust ventilation leading to a safe location^{*(3) & (4)} on open deck.

Footnotes **safe location**^{*(3)} and **safe location**^{*(4)}.

Safe location^{*(3)}: hydrogen by-product enriched gas from:

- in-line full flow electrolysis BWMS (category 4), in-line side-stream electrolysis BWMS (category 5) and in-line injection BWMS using chemical which is stored onboard (category 6): the hydrogen de-gas arrangement (when provided);

safe locations on the open deck are:

- not within 5 m of any source of ignition and from deck machinery, which may include anchor windlass and chain locker openings, and equipment which may constitute an ignition hazard;
- not within 3 m of areas traversed by personnel; and
- not within 5 m of air intakes from non-hazardous enclosed spaces.

The areas on open deck, or semi-enclosed spaces on open deck, within 3 m of the outlets are to be categorized hazardous zone 1 plus an additional 1,5 m surrounding the 3 m hazardous zone 1 is to be categorized hazardous zone 2.

Electrical apparatus located in the above hazardous areas zone 1 and zone 2 is to be suitable for at least IIC T1.

Safe location^{*(4)}: For in-line ozone injection BWMS (categories 7a and 7b), vent outlet from O₃ destructor device (ODS) can be considered as oxygen-enriched air provided that:

- the ODS are duplicated; and
- the manufacturer justified that the quantity of consumable (activated carbon) used by the ODS is sufficient for the considered life cycle of the BWMS; and
- ozone detection is arranged in the vicinity of the discharge outlet from the vent outlet of the ODS to alarm the crew in case the ODS is not working.

If one of the above 3 conditions is not fulfilled, the safe location from ODS on open deck are:

- outside of hazardous area;
- not within 3 m of any source of ignition;
- not within 6 m of areas traversed by personnel; and
- not within 6 m of air intakes for machinery (engines and boilers) and all ventilation inlets.

- .4 The routing of the piping system is to be kept away from any source of heating, ignition and any other source that could react hazardously with the dangerous gas or liquid conveyed inside. The pipes are to be suitably supported and protected from mechanical damage.
- .5 Pipes carrying acids are to be arranged so as to avoid any projection on crew in case of a leakage.
- .6 H₂ by-product enriched air vent pipes (BWMS categories 4, 5 and 6) or O₂ enriched air vent pipes (BWMS categories 3a, 7a, 7b and 8) or O₃ piping (BWMS categories 7a and 7b) shall not be routed through accommodation spaces, services spaces and control stations.
- .7 O₂ enriched air vent pipes (BWMS categories 3a, 7a, 7b and 8) shall not be routed through hazardous areas unless it is arranged inside double walled pipes or pipe ducts constructed as the special safeguard for the purpose of 4.5.4.3.3.2.1 (3.3.2.1) Note 1) and provided with suitable gas detection as described in 4.5.4.3.3.1.4 (3.3.1.4) and mechanical exhaust ventilation as described in 4.5.4.3.3.2.3 (3.3.2.3).
- .8 The routing of H₂ by-product enriched air vent pipes (BWMS categories 4, 5 and 6) or O₂ enriched air vent pipes (BWMS categories 3a, 7a, 7b and 8) is to be as short and as straight as possible. When necessary, horizontal portions may be arranged with a minimum slope in accordance with the manufacturer's recommendation. (3.3.2)

4.5.4.3.3.3 For BWMS using chemical substances or dangerous gas which are stored on-board for either:

- storage or preparation of the active substances (BWMS categories 2 and 6), or
- storage or preparation of the neutralizers (BWMS categories 4, 5, 6, 7a and 7b), or
- recycling the wastes produced by the BWMS (BWMS category 2),

procedures are to be in accordance with the Material Safety Data Sheet and BWM.2/Circ.20 "Guidance to ensure safe handling and storage of chemicals and preparations used to treat ballast water and the development of safety procedures for risks to the ship and crew resulting from the treatment process", and the following measures are to be taken as appropriate:

- .1 The materials, inside coating used for the chemical storage tanks, piping and fittings are to be resistant to such chemicals substances.
- .2 Chemical substances (even if they are not defined as dangerous liquid in the sense of 4.5.4.2.4 (2.4)) and gas storage tanks are to be designed, constructed, tested, inspected, certified and maintained in accordance with:
 - for independent tanks permanently fixed onboard containing dangerous liquids (e.g. sulfuric acid H₂SO₄) or dangerous gas (e.g. oxygen O₂): the Classification Rules as applicable to pressure vessels
 - for independent tanks permanently fixed onboard not containing dangerous liquid (e.g. sodium sulphite, sodium biosulphite or sodium thiosulphate neutralizers) and not containing dangerous gas (e.g. nitrogen N₂): the Classification Rules or other industry standard recognized by the Classification Society
 - for portable tanks: the *IMDG Code* or other industry standard recognized by the Classification Society.
- .3 When the chemical substances are stored inside integral tanks, the ship's shell plating shall not form any boundary of the tank.

- .4 Dangerous liquids and dangerous gas storage tank air pipes are to be led to a safe location*⁽¹⁾ & ⁽²⁾ on open deck.

For **safe location***⁽¹⁾ and **safe location***⁽²⁾ refer to Footnotes to 4.5.4.3.1.5 (Paragraph 3.1.5)

- .5 An operation manual containing chemical injection procedures, alarm systems, measures in case of emergency, etc. is to be kept onboard.
- .6 Dangerous liquid storage tanks and their associated components like pumps and filters, are to be provided with spill trays or secondary containment system of sufficient volume to contain potential leakages from tank openings, gauge glasses, pumps, filters and piping fittings.

Further to the safety and/or pollution assessment of the concerned chemical substances, consideration should be provided for segregation of the drains from such spill trays (or secondary containment system) or piping systems from engine room bilge system or from cargo pump room bilge system, as applicable. When necessary, arrangement should be provided within the spill trays (or within the secondary containment system) for the detection of dangerous liquid or dangerous gas as defined respectively in 4.5.4.2.3 and 4.5.4.2.4 (2.3 and 2.4). **(3.3.3)**

Note: The IMO reports issued during the basic and final approval procedures of the BWMS that make use of active substances (G9 Guideline) could be used for this assessment.

4.5.4.3.3.4 A risk assessment is to be conducted in a generic manner during the design review mentioned in 3.1.4 and submitted to the Classification Society for approval for the following BWMS categories:

- BWMS category 4: in all cases;
- BWMS category 5: in all cases;
- BWMS category 6: when one of the MSDS indicates that the chemical substance stored on-board is either flammable, toxic, corrosive or reactive;
- BWMS category 7a and 7b: in all cases.

Note: The IMO reports issued during the basic and final approval procedures of the BWMS that make use of active substances (G9 Guideline) could be used as a reference for this assessment.

- .1 The recommended risk assessment techniques for BWMS and other guidances are listed below but not limited to:
- FMEA, FMECA, HAZID, HAZOP, etc.
 - ISO 31010 – Risk Assessment Techniques
 - IACS Recommendation Rec. 146
 - Rules of the Classification Society for risk assessment techniques
- .2 The risk assessment should ensure that the package supplied by the BWMS’s manufacturer is intrinsically safe and/or provides mitigation measures to the hazards created by the BWMS which have been identified during the design review mentioned in 4.5.4.3.1.4 (3.1.4) but that need to be implemented during the installation on-board. **(3.3.4)**

Annex I – Installation of one single BWMS on tankers

Table 1: In-line BWMS’s technologies categorization

Note: This Annex does not cover In-tank technologies categories 3c and 8.

BWMS's Technology category → Characteristics ↓		1	2	3a	3b	4	5	6	7a	7b
		In-line UV or UV + Advanced Oxidation Technology (AOT) or UV + TiO ₂ or UV + Plasma	In-line Flocculation	In-line membrane separation and de-oxygenation (injection of N ₂ from N ₂ Generator)	In-line de-oxygenation (injection of Inert Gas from Inert Gas Generator)	In-line full flow electrolysis	In-line side-stream electrolysis (2)	In-line (stored) chemical injection	In-line side-stream ozone injection without gas/liquid separation tank and without discharge treatment tank	In-line side-stream ozone injection with gas/liquid separation tank and without Discharge water treatment tank
Des-infection when ballasting	Making use of active substance		X			X	X	X	X	X
	Full flow of ballast water is passing through the BWMS	X	X	X	X	X				X
	Only a small part of ballast water is passing through the BWMS to generate the active substance						X			
After-treatment when de-ballasting	Full flow of ballast water is passing through the BWMS	X								X
	Injection of neutralizer					X	X	X	X	X
	Not required by the Type Approval Certificate issued by the Administration		X	X						
Examples of dangerous gas as defined in UR M74 §2.3			(1)	O ₂ N ₂	CO ₂ CO	H ₂ Cl ₂	H ₂ Cl ₂	(1)	O ₂ , O ₃ , N ₂	
Arrangement of one single BWMS	BWMS is located in the outside the cargo area	Not Acceptable	Case 1.2 (2)	Case 1.3a (2)	Case 1.3b	Case 1.4 (2)	Case 1.5	Case 1.6	Case 1.7a	Case 1.7b (2)
Notes:										
(1) To be investigated on a case by case basis based on the result of the IMO (GESAMP) MEPC report for Basic and Final approval in accordance with the G9 Guideline.										
(2) Only «Means of dis-connection» as described in 3.2.3.1 are to be applied.										
(3) In-line stream electrolysis may also be applied in-tank in circulation mode (no treatment when ballasting or de-ballasting).										

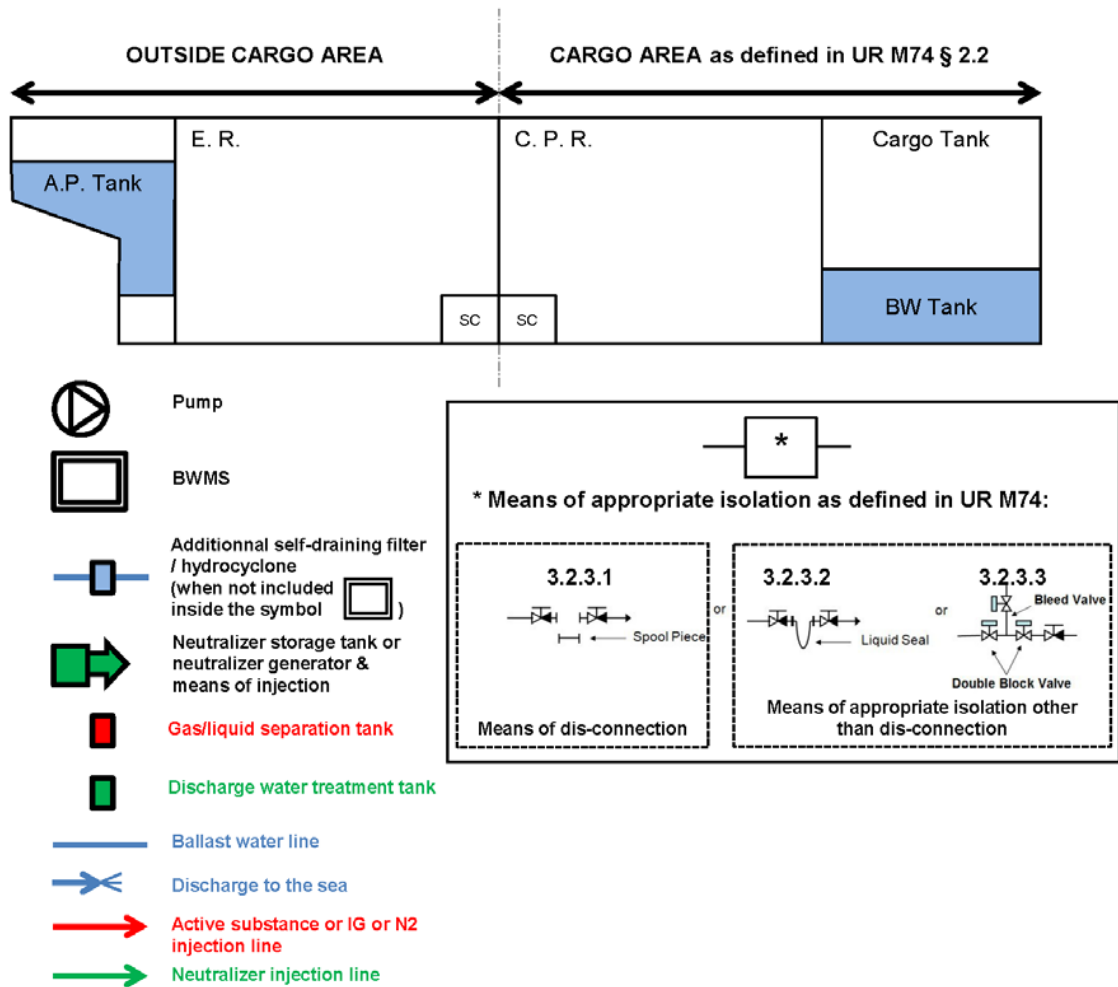

BWMS installed outside the cargo area
Case 1.2 (Technology category 2, Flocculation); and
Case 1.3a (Technology category 3a De-oxygenation with N2 Generator)

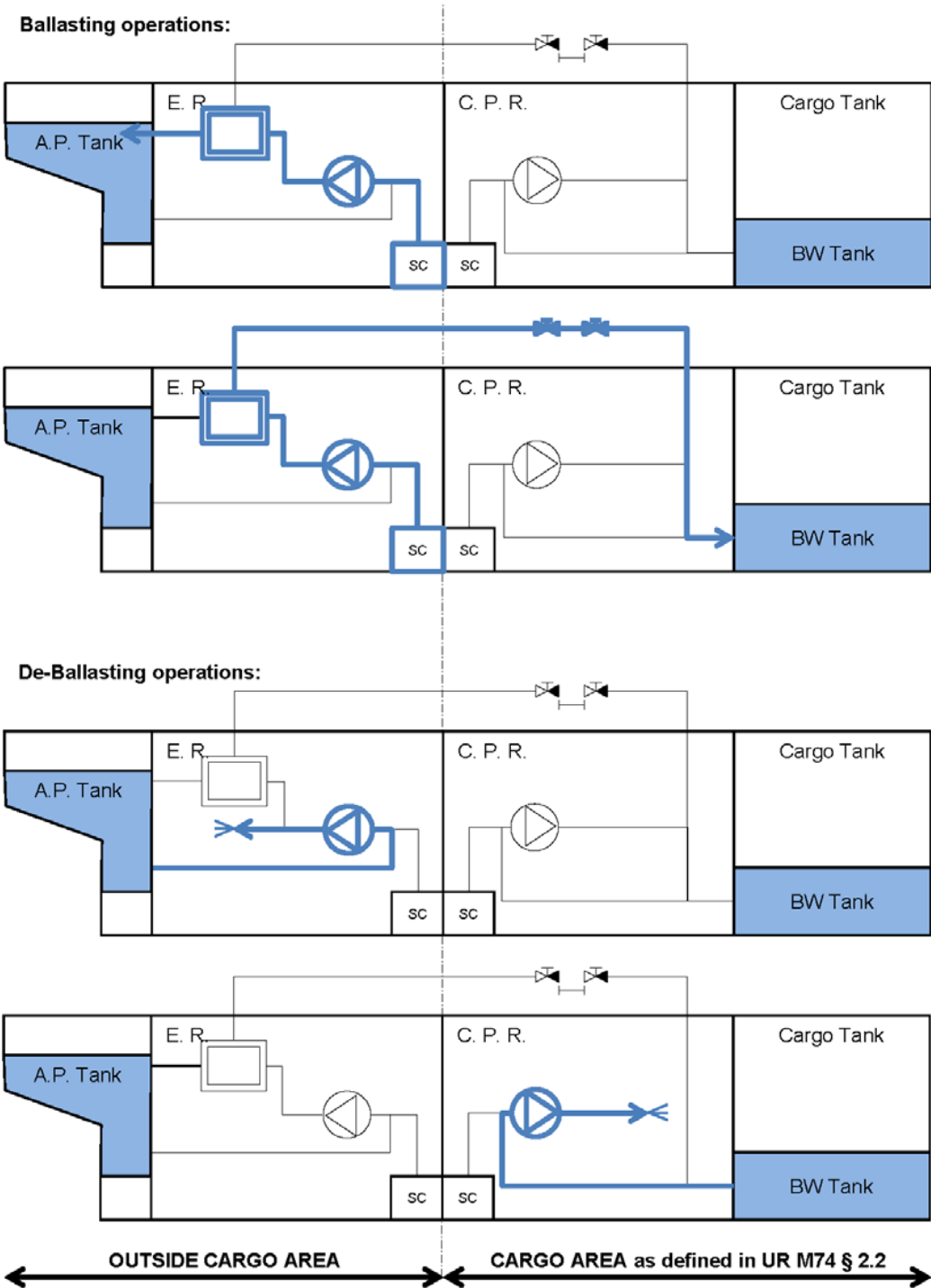

BWMS installed outside the cargo area

Case 1.3b (Technology category 3b, De-oxygenation with Inert Gas Generator):

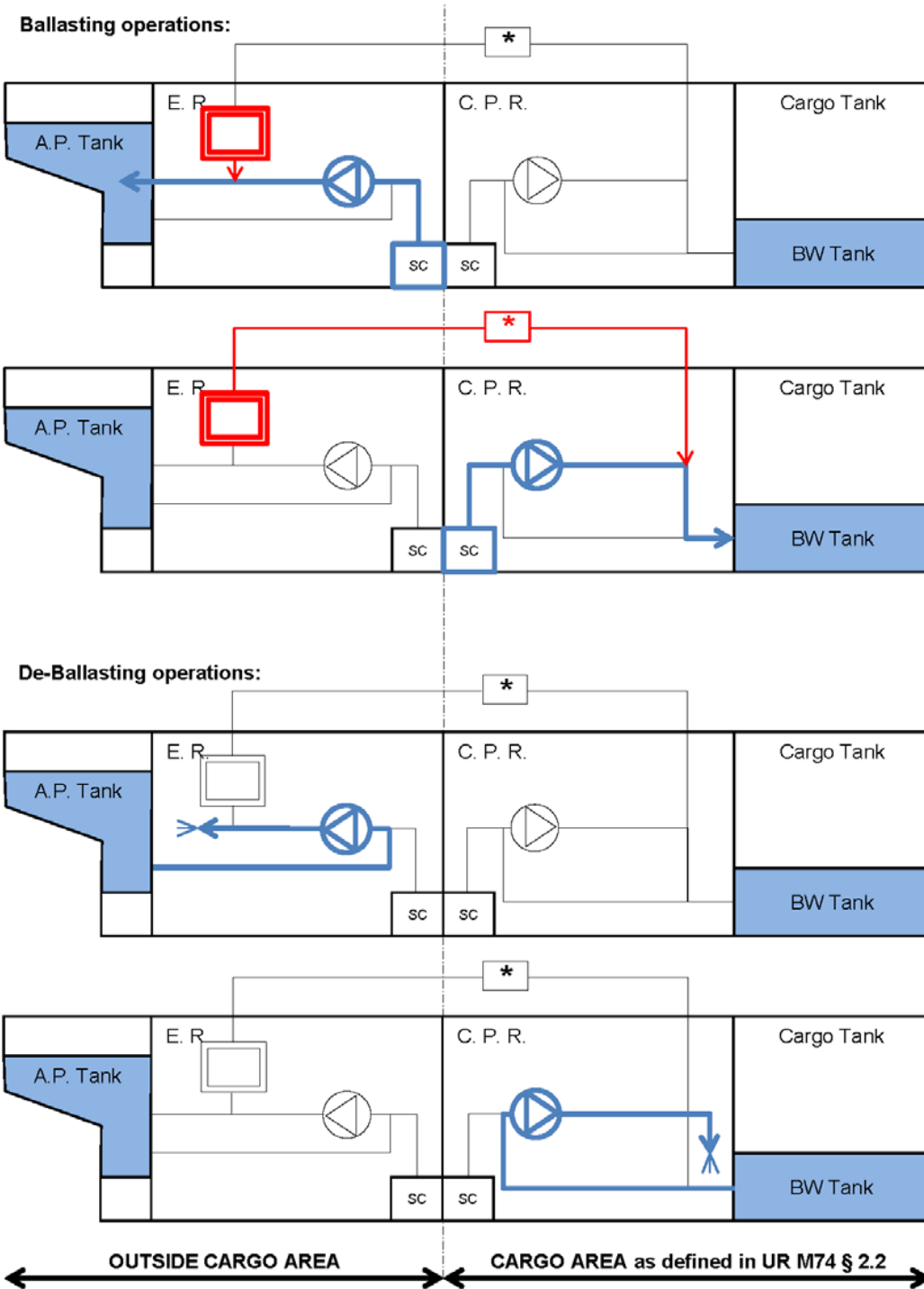

BWMS installed outside the cargo area
Case 1.4 (Technology category 4, Full-flow electrolysis):

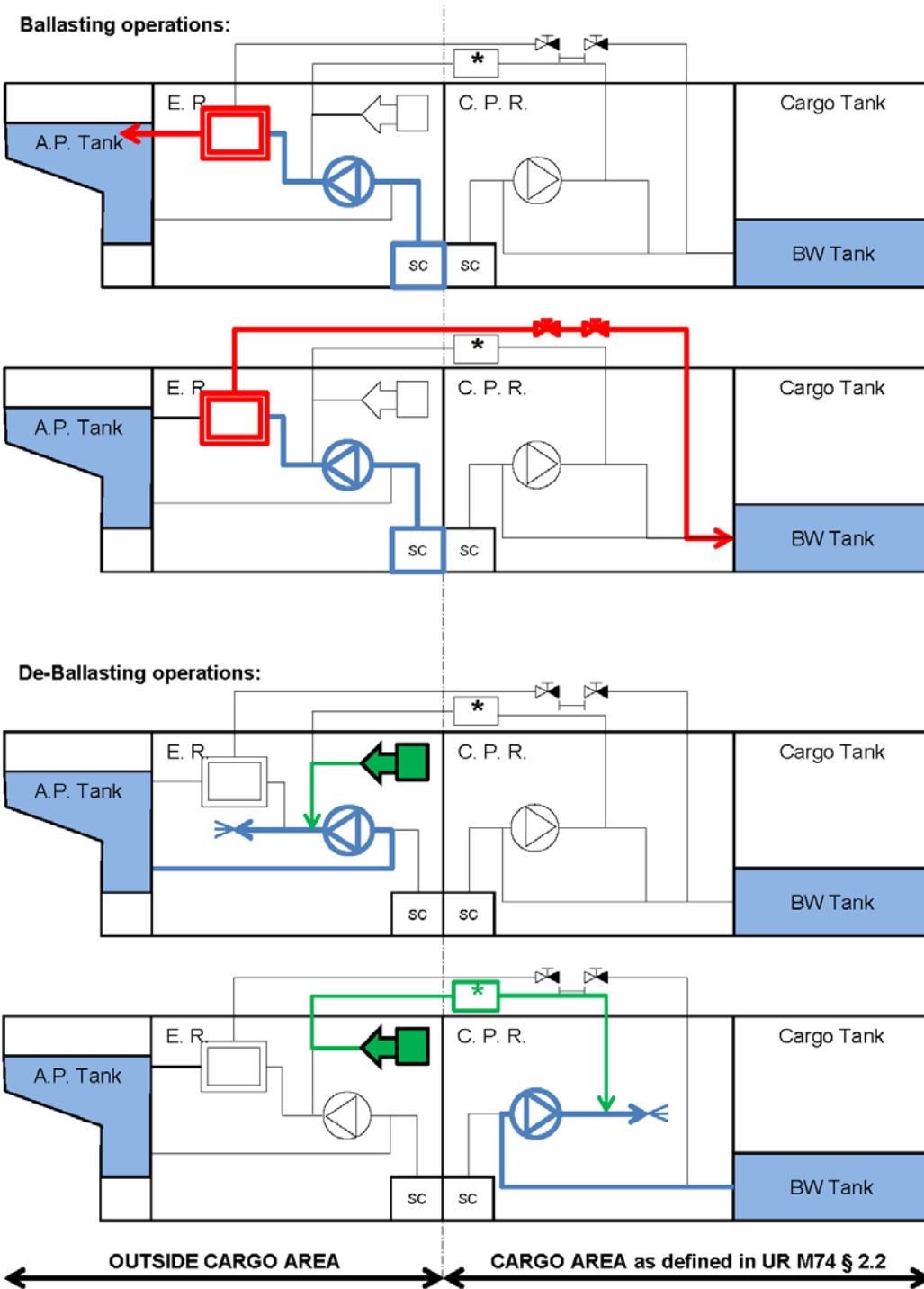

BWMS installed outside the cargo area

Case 1.5 (Technology category 5, Side-stream electrolysis):

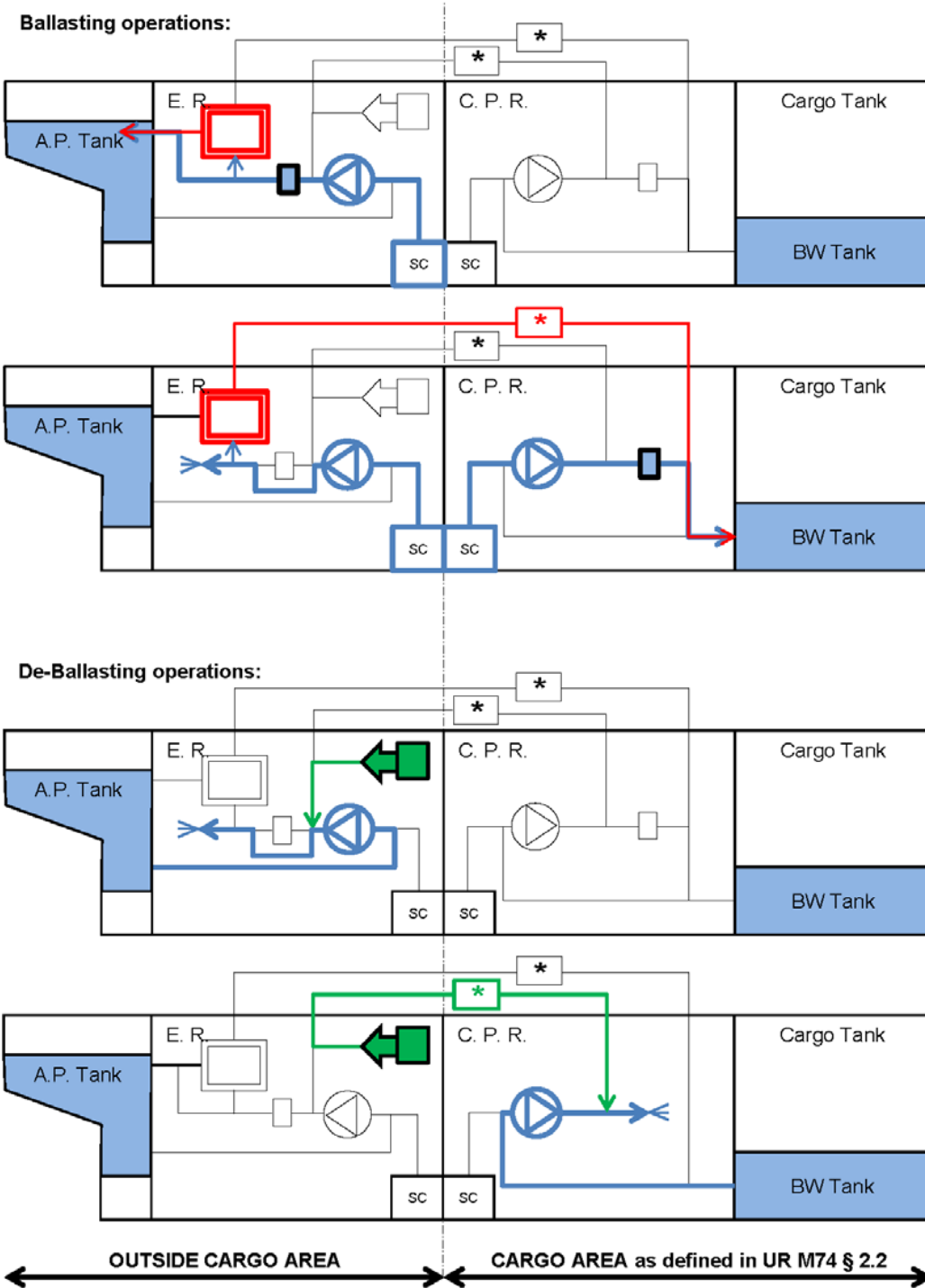

BWMS installed outside the cargo area
Case 1.6 (Technology category 6, Stored chemical injection)

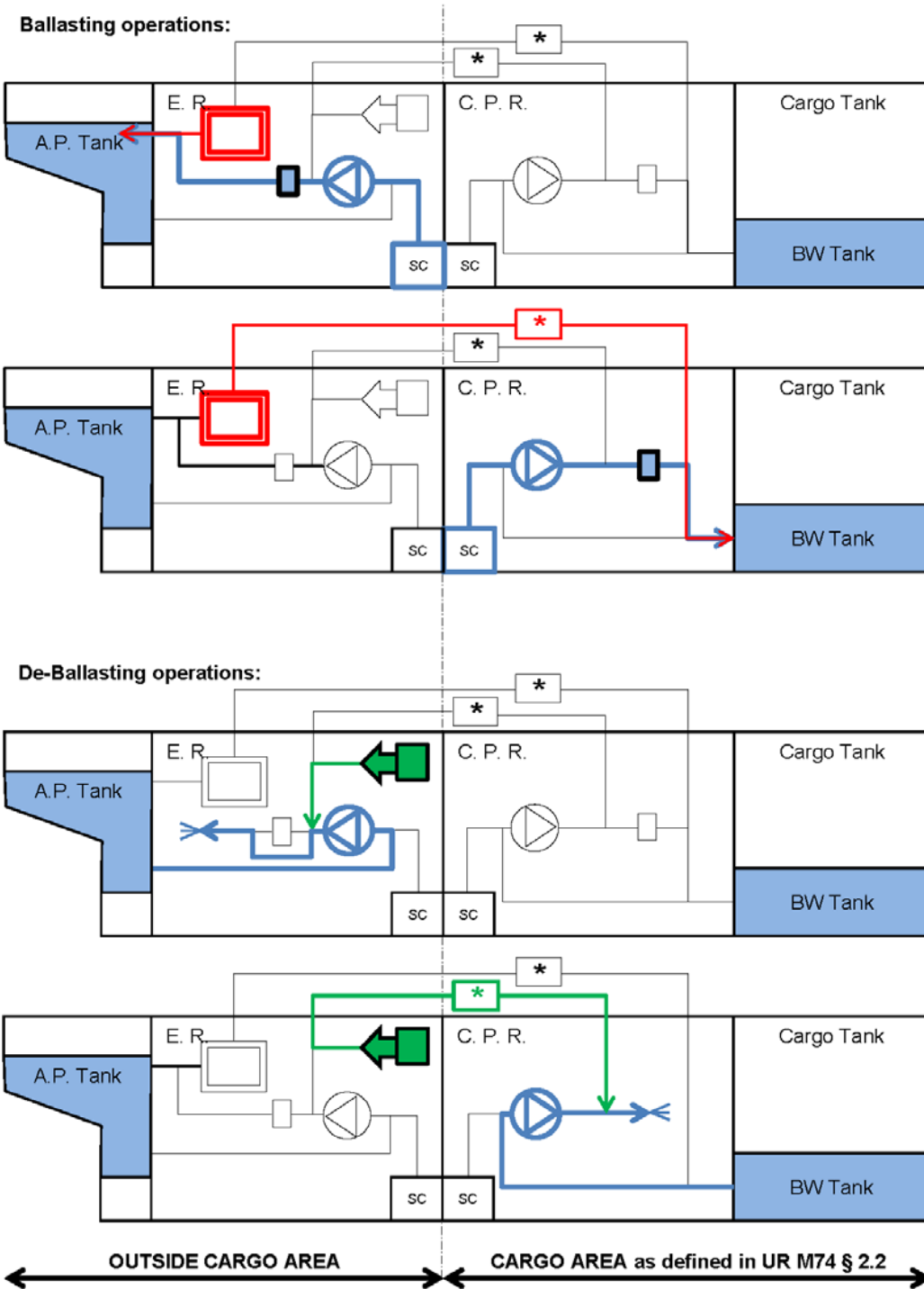

BWMS installed outside the cargo area

Case 1.7a (Technology category 7a, Side-stream ozone injection without gas/liquid separation tank and without discharge water treatment tank):

Ballasting operations:

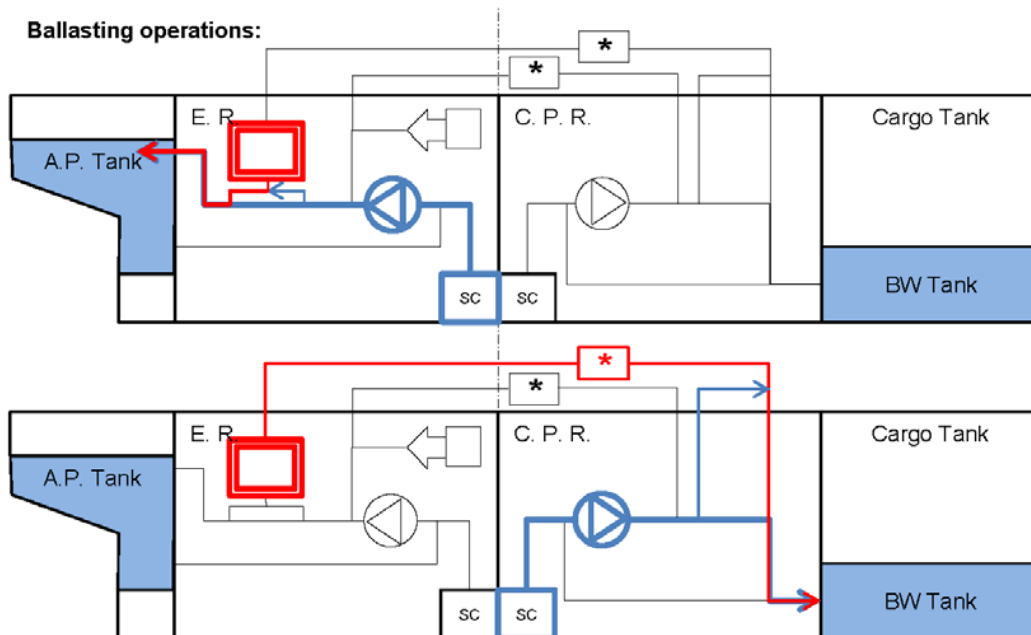

De-Ballasting operations:

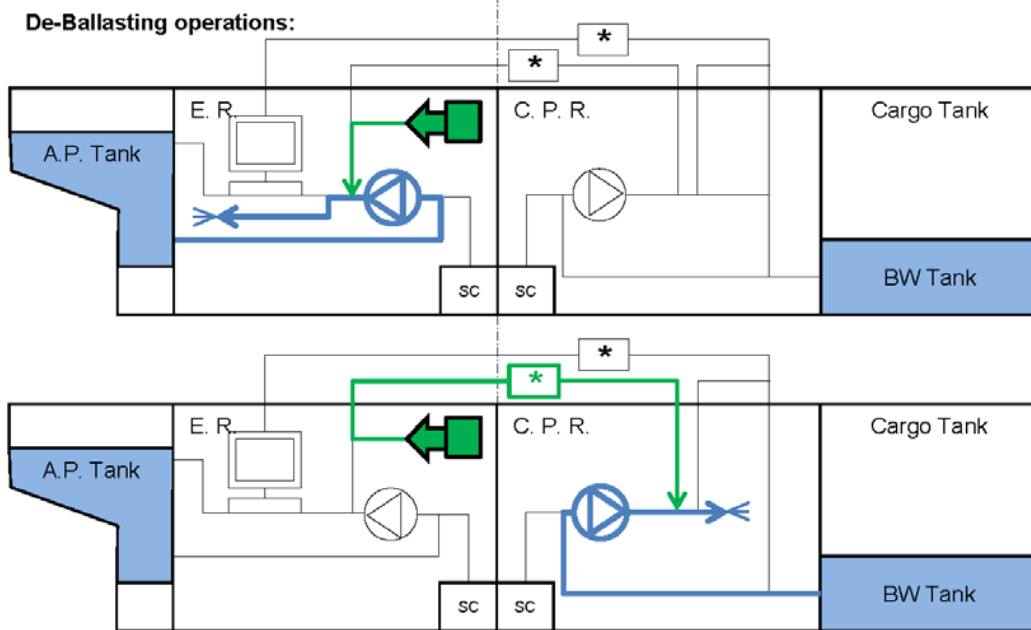

← OUTSIDE CARGO AREA | CARGO AREA as defined in UR M74 § 2.2 →

BWMS installed outside the cargo area

Case 1.7b (Technology category 7b, Side-stream ozone injection with gas/liquid separation tank and discharge water treatment tank):

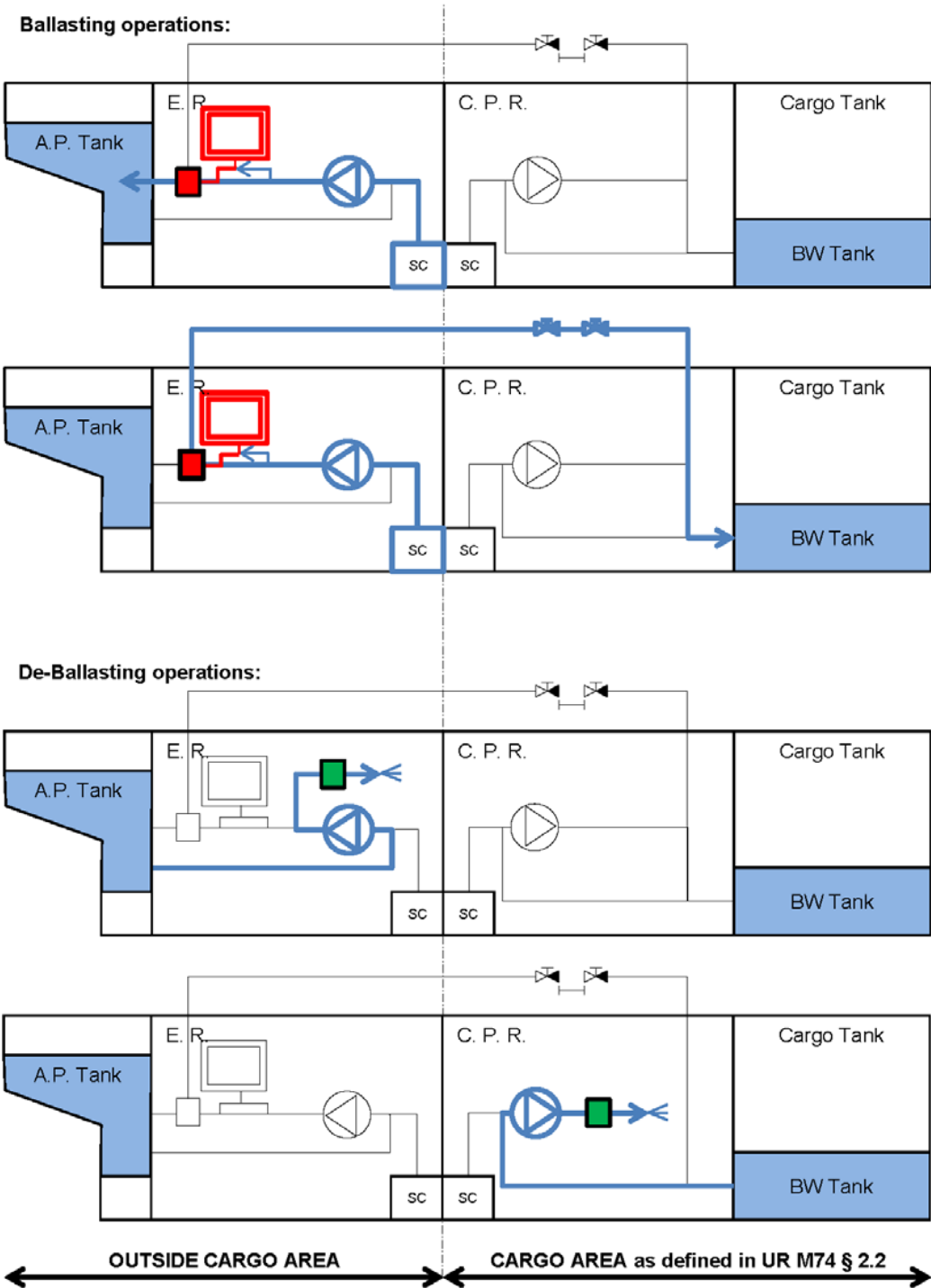

Annex II (INFORMATIVE) BWMS Technologies categorization

BWMS Technology Group no. 1 In-Line UV including UV + AOT Including UV+TiO₂)

Ballasting operation:

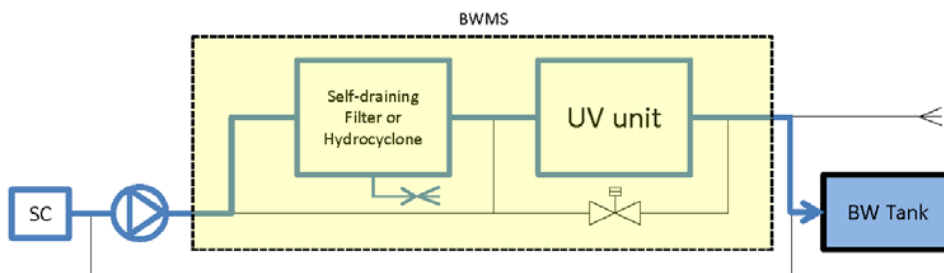

De-ballasting operation:

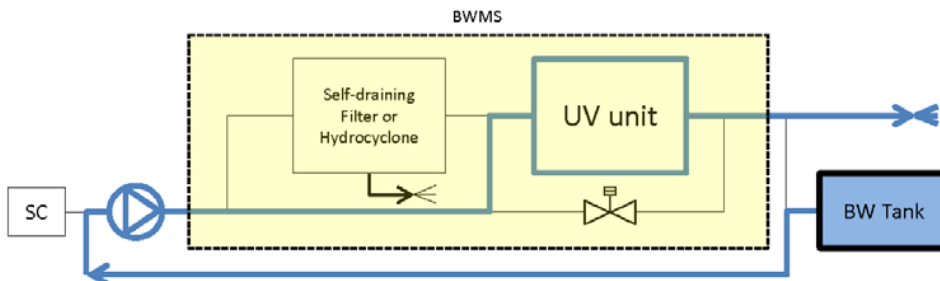

BWMS Technology Group no. 2 In-Line Flocculation

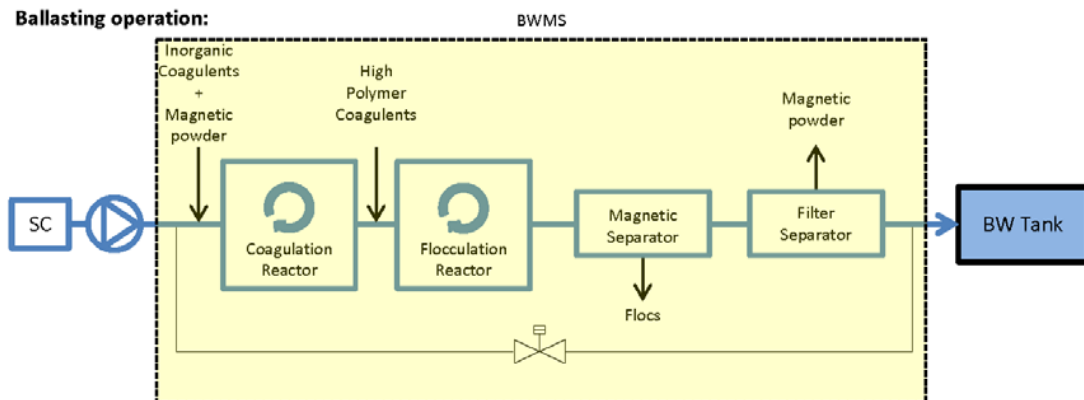

De-ballasting operation: no requirement for after-treatment

BWMS Technology Group no. 3a In-Line membrane separation and de-oxygenation (injection of N₂ from N₂ Generator)

Ballasting operation:

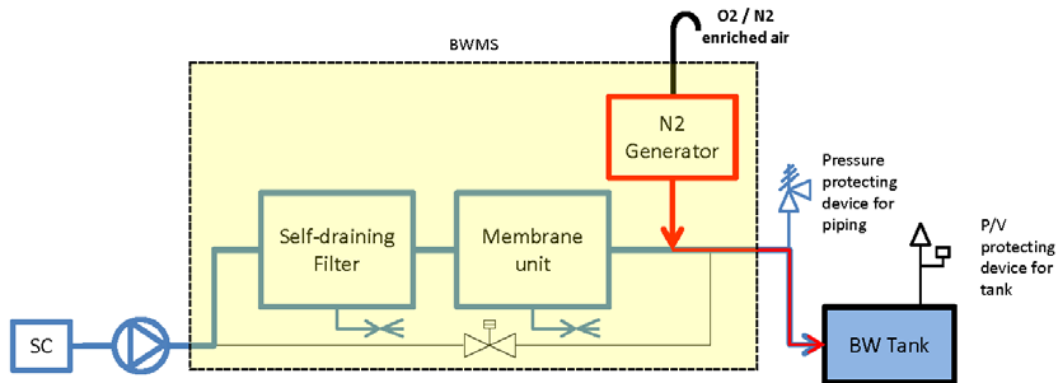

De-ballasting operation: no requirement for after-treatment

BWMS Technology Group no. 3b
In-Line de-oxygenation
(injection of inert gas from either an oil fired inert gas generator or inert gas from treatment of the flue gas from main or auxiliary boilers)

Ballasting operation:

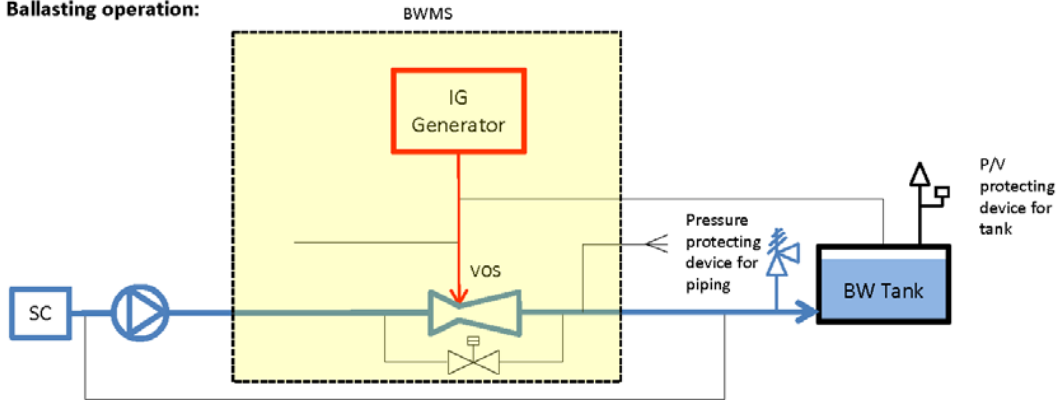

De-ballasting operation:

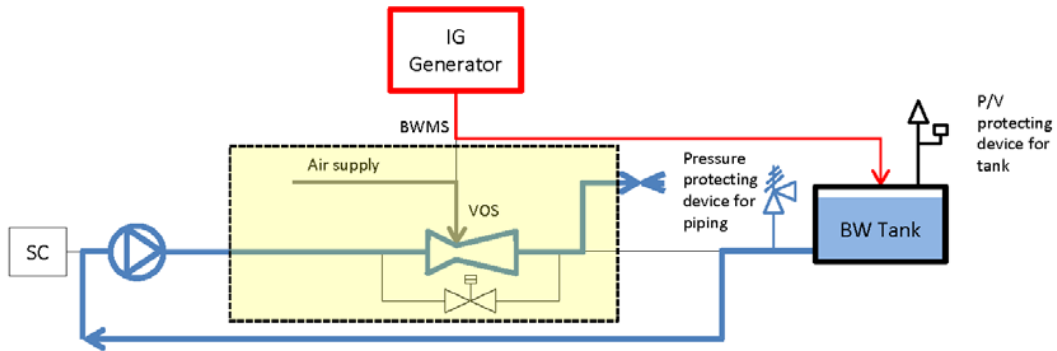

BWMS Technology Group no. 3c In-tank de-oxygenation with IGG

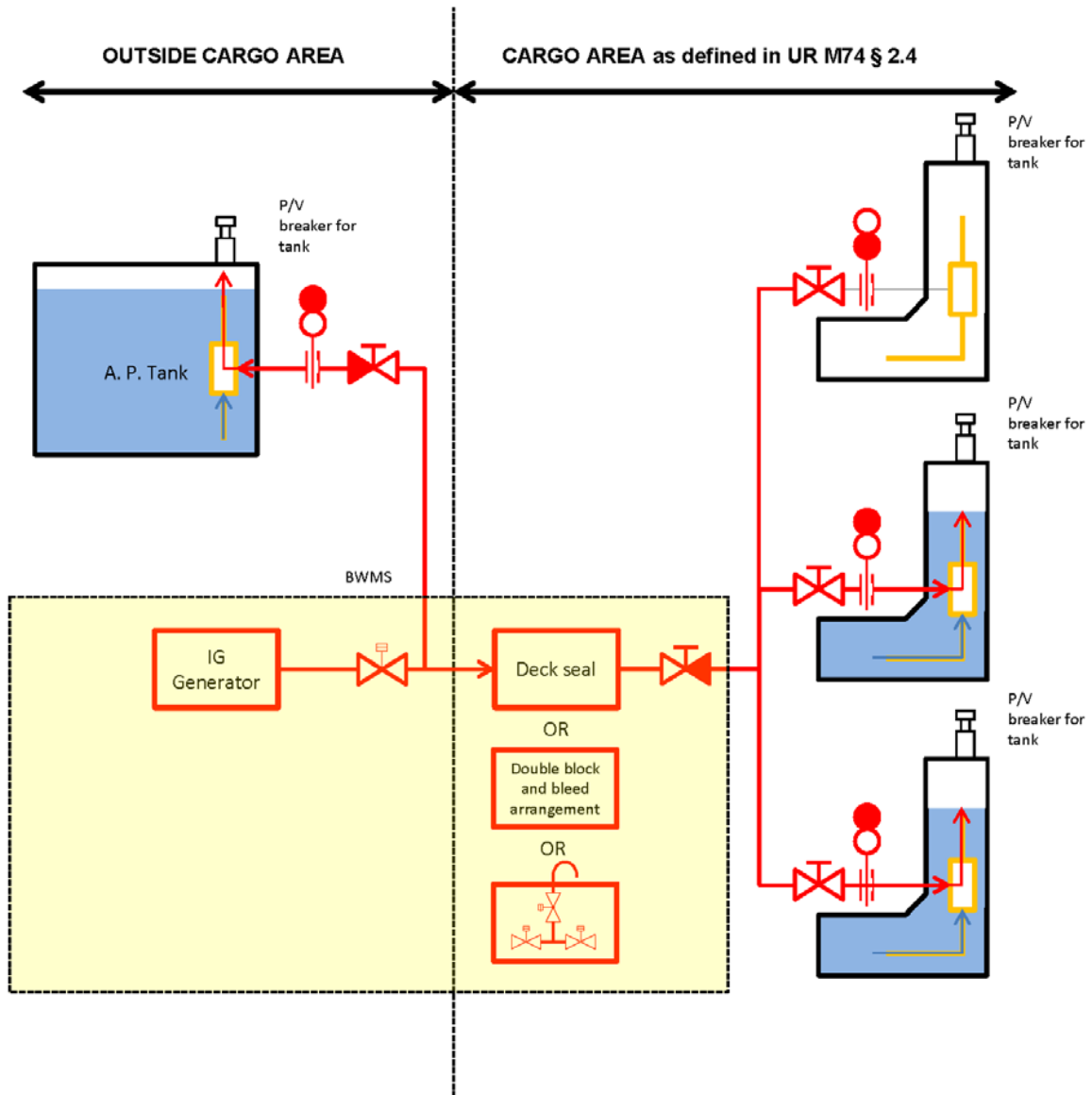

BWMS Technology Group no. 4 In-Line Full flow electrolysis

Ballasting operation:

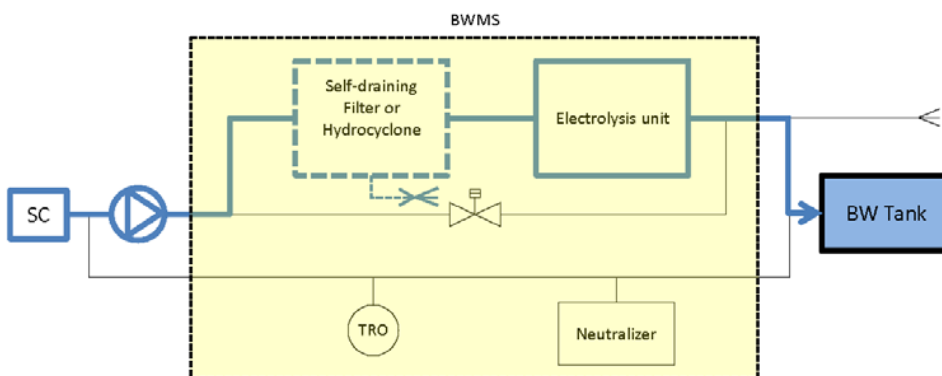

De-ballasting operation:

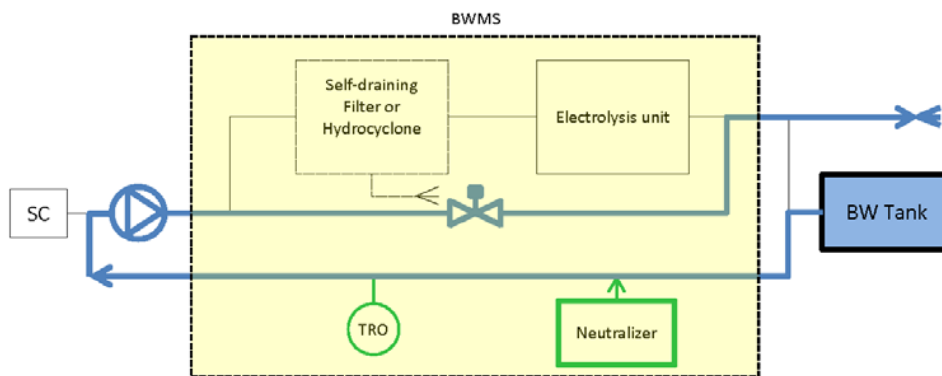

BWMS Technology Group no. 5 In-Line Side-Stream electrolysis (electro-chlorinization)

Note: In-line side stream electrolysis may also be applied in-tank in circulation mode (no treatment when ballasting or de-ballasting)

Ballasting operation:

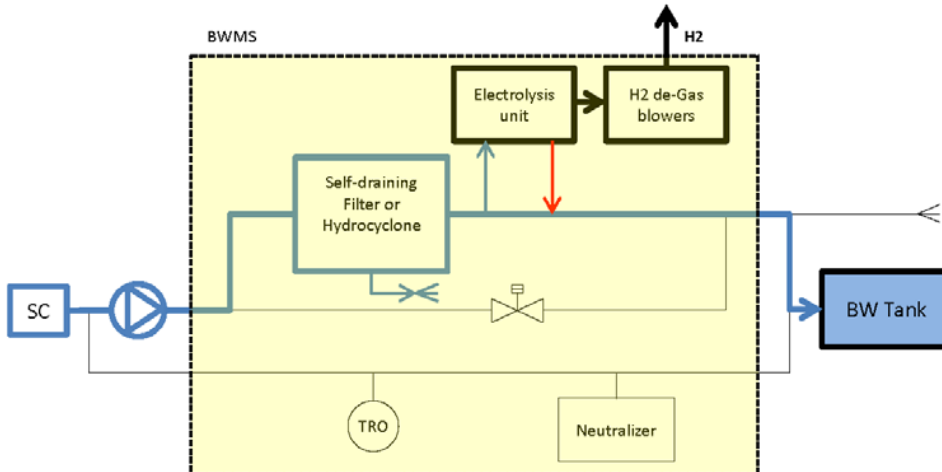

De-ballasting operation:

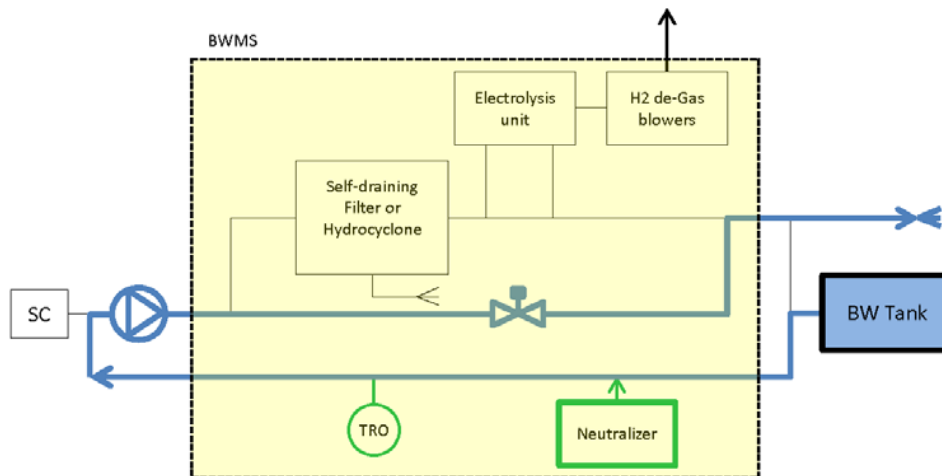

BWMS Technology Group no. 6 In-Line Chemical injection

Ballasting operation:

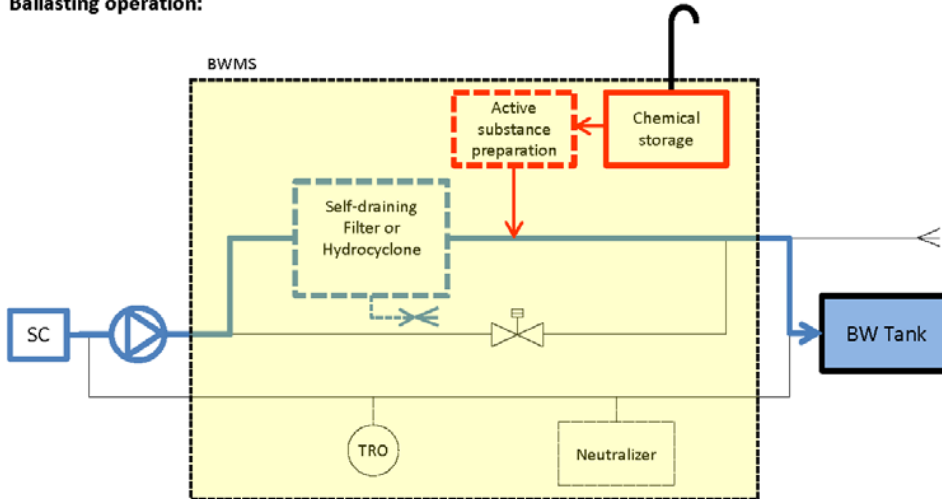

De-ballasting operation (when neutralization is required by the Type Approval certificate):

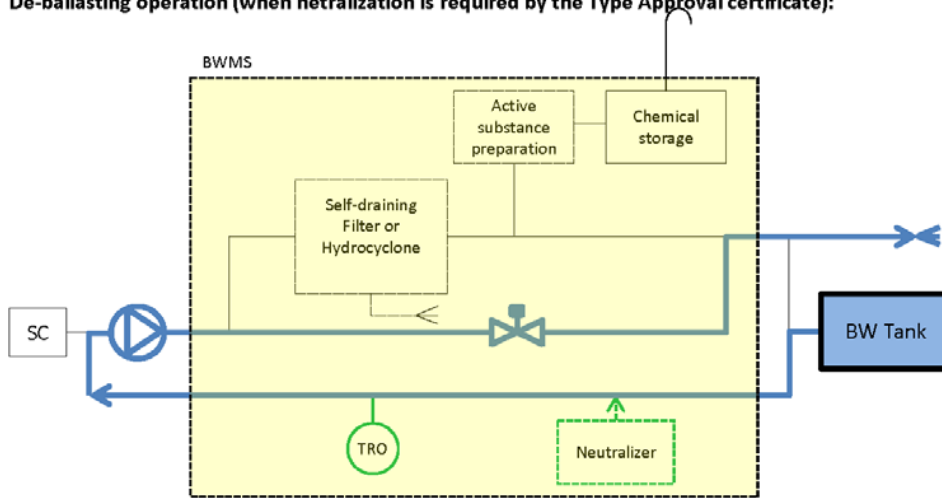

BWMS Technology Group no. 7a
In-Line Side-stream Ozone injection without gas/liquid separation tank and without discharge water treatment tank

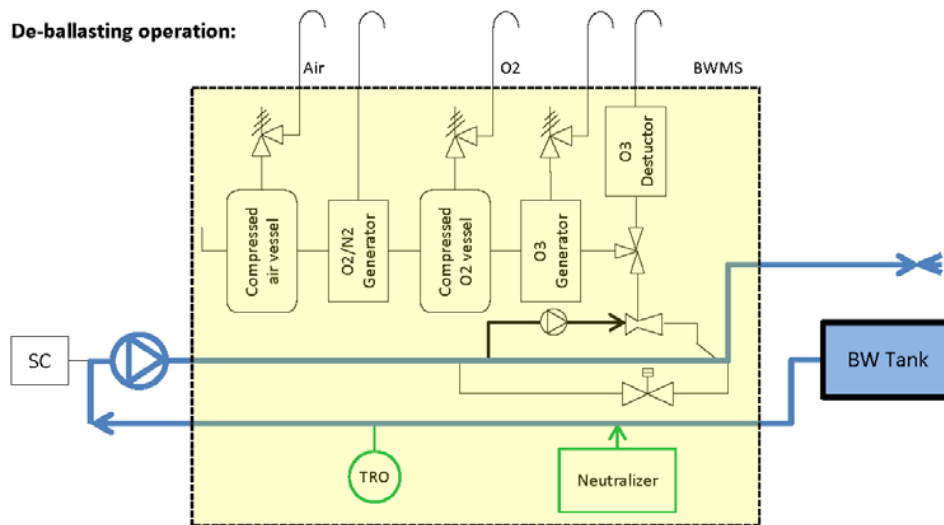
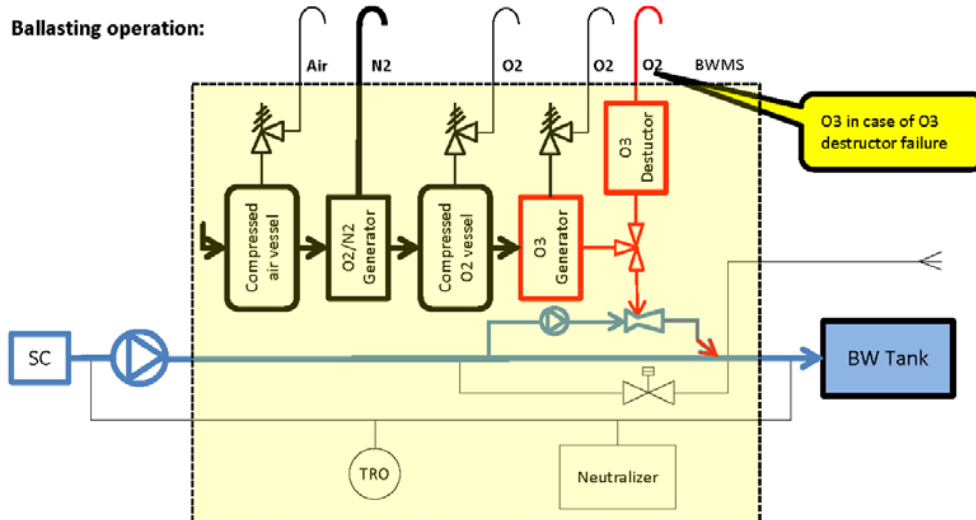

BWMS Technology Group no. 7b
In-Line Side-stream Ozone injection with gas/liquid separation tank and with discharge water treatment tank

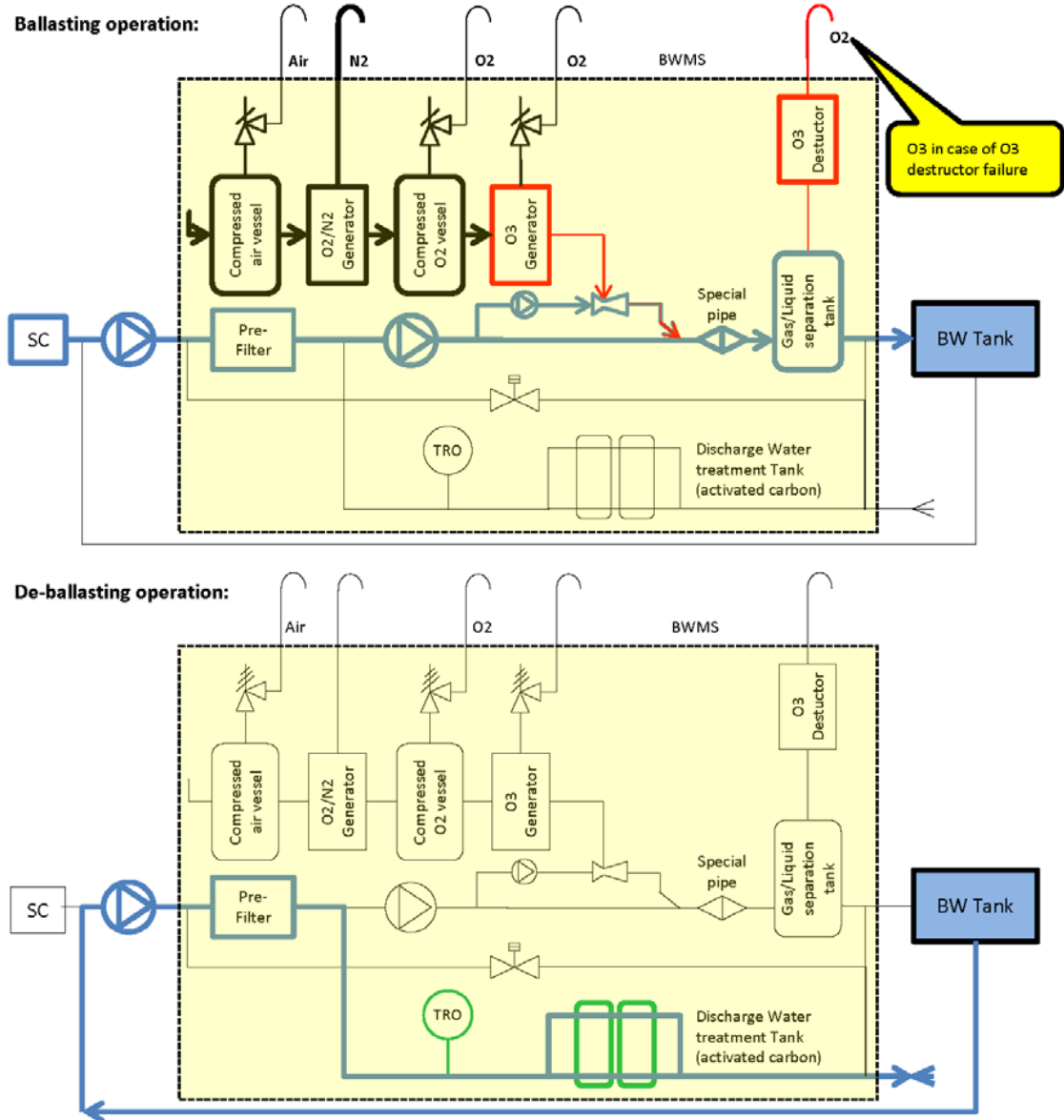

BWMS Technology Group no. 8 In-tank Pasteurization + de-oxygenation with N2 Generator

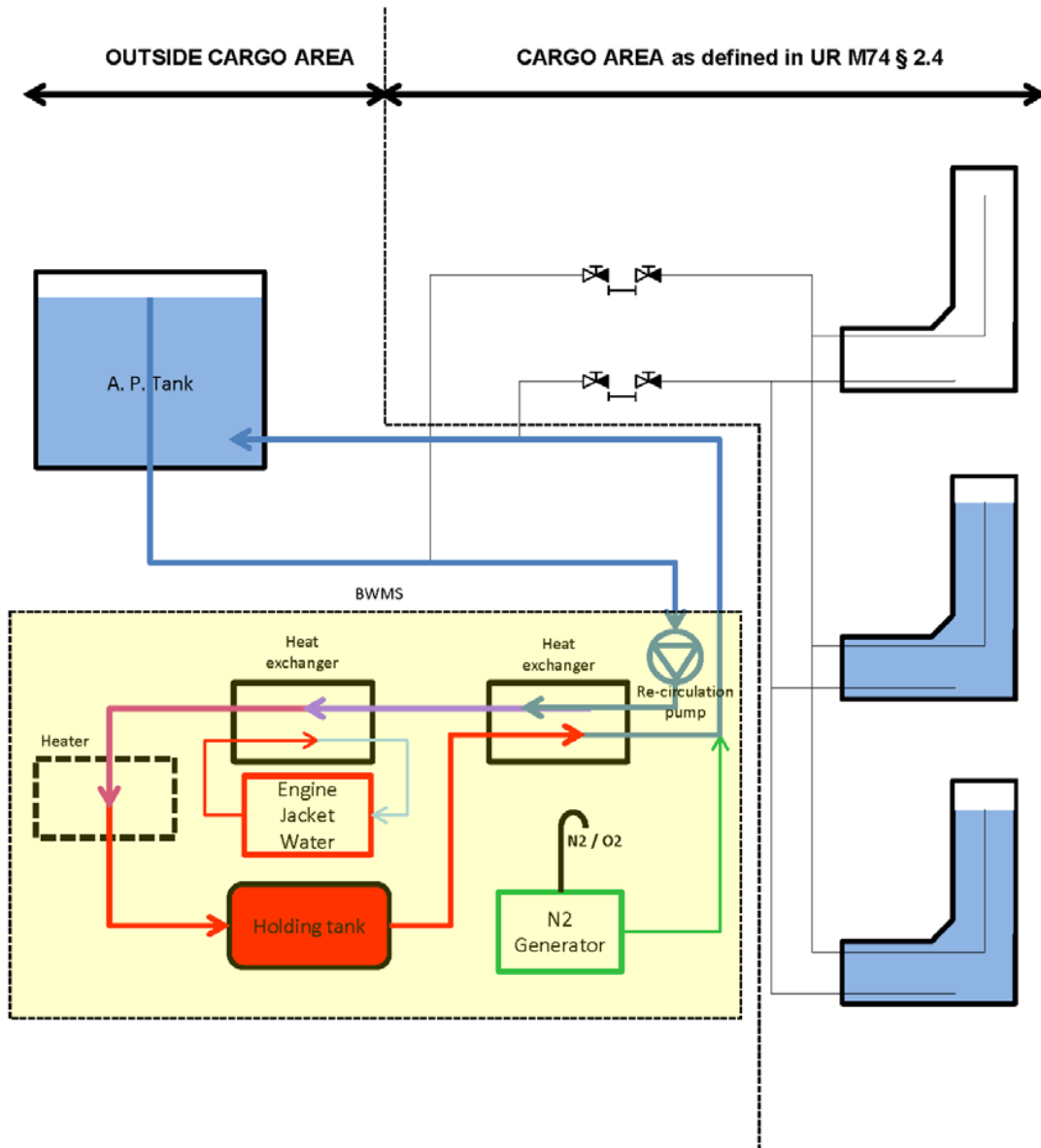

END OF IACS UR M74

CHAPTER 5**5 AIR AND SOUNDING PIPES****5.1 Air pipes – general requirements**

5.1.1 Each ship's tank intended for the storage of liquid, every cofferdam and every void space as well as the side and bottom sea chests and boxes of shell coolers, shall be fitted with air pipes.

5.1.2 Air pipes of side and bottom sea chests and boxes of shell coolers shall be fitted with shut-off valves installed directly on those chests and boxes.

5.1.3 Tank air pipes shall be led from the upper part of the tank from a place situated at the maximum distance from the filling pipe. The number and arrangement of the air pipes shall be determined depending on the shape and size of the tanks so as to preclude the formation of air pockets.

5.1.4 Tanks extending from ship's side to side shall be fitted with air pipes at both sides. Air pipes must not be used as filling pipes unless the tank is fitted with more than one air pipe.

5.1.5 Arrangement of air pipes shall be such that under normal list and trim conditions no hydraulic seals may occur in the pipes.

5.1.6 It is not recommended that air pipes be led through refrigerated spaces. Where such leading is indispensable, the pipes shall be properly insulated.

5.1.7 Air pipes of sea-water tanks and lubricating oil tanks may be led through oil fuel tanks without tight tunnels forming an integral part of such tanks provided that seamless pipes and permanent joints are used. Where the use of detachable joints is indispensable, flange joints with gaskets resistant to the effect of oil shall be used.

5.1.8 Air pipes of tanks intended for different kinds of liquids shall not be interconnected.

5.1.9 Air pipes of double bottom tanks, tanks adjacent to the external shell plating, side and bottom sea chests and boxes of shell coolers shall be led above the bulkhead deck.

5.1.10 Air pipes from thermal oil expansion and storage tanks shall be led to the open deck.

5.1.11 Air pipes shall terminate in the places where the possibility of damage of the pipes during cargo handling operations is precluded.

5.1.12 Location and arrangement of vent pipes for fuel oil service, settling and lubrication oil tanks shall be such that in the event of a broken vent pipe this shall not directly lead to the risk of ingress of seawater splashes or rainwater. (...) (SOLAS Reg. II-1/26.11)

5.1.13 (...) Air (...) pipes (...) shall discharge to a position* where there is no risk of fire or explosion from the emergence of oils and vapour and shall not lead into crew spaces, passenger spaces nor into special category spaces, closed ro-ro cargo spaces, machinery spaces or similar spaces. (SOLAS Reg. II-2/4.2.2.4)

*** IMO interpretation**

Air pipes from oil fuel tanks or heated lubricating oil tanks should be led to a safe position on the open deck. They should not terminate in any place where a risk of ignition is present. Air pipes from unheated lubricating oil (including hydraulic oil) tanks may terminate in the machinery space, provided that the open ends are so situated that issuing oil cannot come into contact with electrical equipment or heated surfaces. (MSC/Circ.1120)

Notes:

1. This requirement i.e. 5.1.13 applies to fuel oil, lubricating oil and other flammable oil tanks. (SOLAS Reg. II-2/4.2.3.1, Reg. II-2/4.2.4)
2. Paragraph 1 of IACS UR F35 contains similar requirement concerning air pipes hence they are not repeated here.

5.1.14 When air pipes from unheated lubricating oil (including hydraulic oil) tanks terminate in the machinery space an alarm device shall be provided to give warning when the oil reaches a predetermined level in the tank, or alternatively a sight glass shall be provided in the overflow pipe to indicate when any tank is overflowing. Such sight glasses shall be placed on vertical pipes only and in readily visible positions.

5.1.15 Where air pipes to ballast and other tanks extend above the freeboard or superstructure decks, the exposed parts of the pipes shall be of substantial construction*; the height from the deck to the point where water may have access below shall be at least 760 mm on the freeboard deck and 450 mm on the superstructure deck. (LL, Annex 1, Reg. II/20(1))

For ships of restricted service, receiving in their symbol of class additional mark **I**, **II** or **III**, the height of air pipes may be reduced to 600 mm and 380 mm, respectively.

*** IACS interpretation**

Minimum wall thickness of pipes (Regulations 19, 20 and 22)

For pipes covered by the above Regulations the following minimum wall thicknesses are recommended:

(a) (i) (...)

and

(ii) *For venting pipes other than specified under (c):*

Note:

Venting pipes should be construed as air pipes.

- external diameter of pipes equal to or less than 155 mm: thickness not less than 4.5 mm
 - external diameter of pipes equal to or more than 230 mm: thickness not less than 6.0 mm
- intermediate sizes are to be determined by linear interpolation.

(b) (...)

(c) *For venting pipes in position 1 and 2 leading to spaces below the freeboard deck or to spaces within enclosed superstructures:*

- external diameter of pipes equal to or less than 80 mm: thickness not less than 6.0 mm
 - external diameter of pipes equal to or more than 165 mm: thickness not less than 8.5 mm
- intermediate sizes are to be determined by linear interpolation.

(...) (IACS UI LL36)

Notes:

1. Positions 1 and 2 . as defined in regulation 13 of the *International Convention on Load Lines* – see Part III, 7.1.4.
2. Provisions of (a)(i) and (b) concern scuppers and they are included in 2.2.13.

5.1.16 Where these heights may interfere with the working of the ship, a lower height may be approved, provided that the Administration is satisfied that the closing arrangements and other circumstances justify a lower height. (LL, Annex 1, Reg. II/20(2))

5.1.17 Air pipes shall be provided with automatic closing devices*. (LL, Annex 1, Reg. II/20(3))

*** IACS interpretation**

Where required by Regulation 20 air pipe closing devices shall be weathertight. Closing devices shall be automatic if, while the vessel is at its draught corresponding to summer load line, the openings of air pipes to which these closures are fitted submerge at angles up to 40° or up to a lesser angle which may be agreed on the basis of stability requirements. (...)

Wooden plugs and trailing canvas hoses shall not be accepted in position 1 and position 2. (...) (IACS UI LL49)

5.1.18 Open ends of air pipes situated on the freeboard open decks and on the first tier superstructure decks, as well as those situated above these decks within the zone limited by the angle of downflooding shall be fitted with fixed, self-acting closing devices (vent heads) of a type approved by PRS preventing the entry of sea-water into the tanks. This requirement does not apply to the compartments permanently filled with sea-water such as side and bottom sea chests and boxes of shell coolers. The ends of air pipes not fitted with the vent heads shall be made as an elbow, with its opening facing downwards or in a different way agreed upon with PRS.

5.1.19 Air pipes of fuel oil tanks shall be fitted with devices preventing the passage of flame resistant to the corrosive effect of sea-water and of a design agreed with PRS (see also 8.4.4).

5.1.20 Air pipes of sewage treatment plants and sewage holding tanks shall be fitted with devices preventing the passage of flame resistant to the corrosive effect of sea-water and of a design agreed with PRS (see also 16.2.9).

5.1.21 Air pipes of oil fuel tanks shall have no detachable joints in way of accommodation and refrigerated spaces.

5.1.22 Containers for collecting the possible oil fuel spills shall be provided for the air pipes of oil fuel tanks in accordance with the requirements specified in 8.6.5.

5.1.23 Air pipes of internal combustion engine crankcases shall fulfil the requirements specified in *Part VII*, 2.2.3.

5.1.24 The total cross-sectional area of air pipes of the tanks filled by gravity shall not be less than the total cross-sectional area of all pipes by which the liquid may be simultaneously delivered into the tank.

5.1.25 The total cross-sectional area of air pipes of tanks filled by the ship's pumps or shore pumps shall be at least 1.25 times the cross-sectional area of the filling pipe. The total cross-sectional area of an air pipe serving several tanks shall be at least 1.25 times the cross-sectional area of the common filling pipeline and the requirements specified in 8.3.10 shall also be fulfilled.

5.1.26 Where a tank filled by the ship's pumps or shore pumps is provided with an overflow pipe, the total cross-sectional area of the air pipes of the tank shall not be less than 0.33 of the cross-sectional area of the filling pipe.

5.1.27 Air pipe internal diameter shall not be less than 50 mm.

5.1.28 Nameplates shall be affixed to the upper ends of air pipes.

5.2 Strength requirements for air pipes on fore deck

IACS UR S27

Note:

Requirements of this UR are applicable to air and ventilator pipes as well as to fore deck equipment (windlasses). Specific requirements for ventilator pipes can be found in *Part III*, 7.7 while for windlasses in *Part VII*, 6.3.10.

5.2.1 General (1.)

5.2.1.1 This subchapter 5.2 (UR S 27) provides strength requirements to resist green sea forces for the following items located within the forward quarter length:

air pipes (...) and their closing devices, (...).

(...) (1.1)

5.2.2 Application (2.)

5.2.2.1 For ships (...) on the exposed deck over the forward $0.25L$, applicable to:

All ship types of sea going service of length 80 m or more, where the height of the exposed deck in way of the item is less than $0.1L$ or 22 m above the summer load waterline, whichever is the lesser.

(2.1)

5.2.2.2 The ship length L is as defined in 1.2.35 (UR S2). (2.3)

5.2.2.3 This UR does not apply to CSR Oil Tankers. (2.4)

(...)

5.2.3 Applied Loading (4.)

5.2.3.1 Air pipes (...) and their closing devices (4.1)

5.2.3.1.1 The pressures p , in kN/m^2 acting on air pipes (...) and their closing devices may be calculated from:

$$p = 0.5\rho V^2 C_d C_s C_p$$

where:

ρ = density of sea water = 1.025 t/m^3

V = velocity of water over the fore deck

= 13.5 m/sec for $d \leq 0.5 d_1$

= $13.5 \sqrt{2(1 - \frac{d}{d_1})} \text{ m/sec}$ for $0.5 d_1 < d < d_1$

d = distance from summer load waterline to exposed deck

d_1 = $0.1L$ or 22 m whichever is the lesser

C_d = shape coefficient

= 0.5 for pipes, 1.3 for air pipe (...) heads in general, 0.8 for an air pipe (...) head of cylindrical form with its axis in the vertical direction.

C_s = slamming coefficient = 3.2

C_p = protection coefficient:

= 0.7 for pipes (...) located immediately behind a breakwater or forecastle,

= 1.0 elsewhere and immediately behind a bulwark. (4.1.1)

5.2.3.1.2 Forces acting in the horizontal direction on the pipe and its closing device may be calculated from 5.2.3.1.1 (4.1.1) using the largest projected area of each component.

(...) (4.1.2)

5.2.4 Strength Requirements (5.)

5.2.4.1 Air pipes (...) and their closing devices (5.1)

5.2.4.1.1 These requirements are additional to 5.3 (IACS Unified Requirement P3) and 5.1.15 (Unified Interpretation LL36) (Footnote *). (5.1.1)

Footnote *: This does not mean that closing devices of air pipes on all existing ships subject to S27 need to be upgraded to comply with 5.3 (UR P3).

5.2.4.1.2 Bending moments and stresses in air (...) pipes are to be calculated at critical positions: at penetration pieces, at weld or flange connections, at toes of supporting brackets. Bending stresses in the net section are not to exceed $0.8\sigma_y$, where σ_y is the specified minimum yield stress or 0.2% proof stress of the steel at room temperature. Irrespective of corrosion protection, a corrosion addition to the net section of 2.0 mm is then to be applied. **(5.1.2)**

5.2.4.1.3 For standard air pipes of 760 mm height closed by heads of not more than the tabulated projected area, pipe thicknesses and bracket heights are specified in Table 1. Where brackets are required, three or more radial brackets are to be fitted. Brackets are to be of gross thickness 8 mm or more, of minimum length 100 mm, and height according to Table 1 but need not extend over the joint flange for the head. Bracket toes at the deck are to be suitably supported. **(5.1.3)**

5.2.4.1.4 For other configurations, loads according to 5.2.3.1 (4.1) are to be applied, and means of support determined in order to comply with the requirements of 5.2.4.1.2 (5.1.2). Brackets, where fitted, are to be of suitable thickness and length according to their height. Pipe thickness is not to be taken less than as indicated in 5.1.15 (IACS UI LL36). **(5.1.4)**

5.2.4.1.5 All component parts and connections of the air pipe (...) are to be capable of withstanding the loads defined in 5.2.3.1 (4.1).

(...) **(5.1.7)**

Table 1: 760 mm Air Pipe Thickness and Bracket Standards

Nominal pipe diameter (mm)	Minimum fitted gross thickness, LL36(c) (mm)	Maximum projected area of head (cm ²)	Height ⁽¹⁾ of brackets (mm)
40A ⁽³⁾	6.0	–	520
50A ⁽³⁾	6.0	–	520
65A	6.0	–	480
80A	6.3	–	460
100A	7.0	–	380
125A	7.8	–	300
150A	8.5	–	300
175A	8.5	–	300
200A	8.5 ⁽²⁾	1900	300 ⁽²⁾
250A	8.5 ⁽²⁾	2500	300 ⁽²⁾
300A	8.5 ⁽²⁾	3200	300 ⁽²⁾
350A	8.5 ⁽²⁾	3800	300 ⁽²⁾
400A	8.5 ⁽²⁾	4500	300 ⁽²⁾

(1) Brackets (see 5.2.4.1.3 (5.1.3)) need not extend over the joint flange for the head.

(2) Brackets are required where the as fitted (gross) thickness is less than 10.5 mm, or where the tabulated projected head area is exceeded.

(3) Not permitted for new ships - reference 1.5 (UR P1).

Note: For other air pipe heights, the relevant requirements of section 5.2.4 (5.) are to be applied.

(...)

END OF IACS UR S27

5.3 Air pipe closing devices

IACS UR P3

5.3.1 General requirements (P3.1)

Where air pipes are required by the Rules of the Classification Society, the *International Convention on Load Lines, 1966* or the *Protocol of 1988* relating to the *International Convention on Load Lines, 1966*, as amended by IMO resolutions up to MSC.375(93) to be fitted with automatic closing devices, they are to comply with the following:

5.3.2 Design (P3.2)

5.3.2.1 Air pipe automatic closing devices are to be so designed that they will withstand both ambient and working conditions, and be suitable for use at inclinations up to and including $\pm 40^\circ$. (P3.2.1)

5.3.2.2 Air pipe automatic closing devices are to be constructed to allow inspection of the closure and the inside of the casing as well as changing the seals. (P3.2.2)

5.3.2.3 Efficient ball or float seating arrangements are to be provided for the closures. Bars, cage or other devices are to be provided to prevent the ball or float from contacting the inner chamber in its normal state and made in such a way that the ball or float is not damaged when subjected to water impact due to a tank being overfilled. (P3.2.3)

5.3.2.4 Air pipe automatic closing devices are to be self-draining. (P3.2.4)

5.3.2.5 The clear area through an air pipe closing device in the open position is to be at least equal to the area of the inlet. (P3.2.5)

5.3.2.6 An automatic closing device is to:

- a) Prevent the free entry of water into the tanks,
- b) Allow the passage of air or liquid to prevent excessive pressure or vacuum coming on the tank. (P3.2.6)

5.3.2.7 In the case of air pipe closing devices of the float type, suitable guides are to be provided to ensure unobstructed operation under all working conditions of heel and trim as specified in 5.3.2.1 (P3.2.1). (P3.2.7)

5.3.2.8 The maximum allowable tolerances for wall thickness of floats should not exceed $\pm 10\%$ of thickness. (P3.2.8)

5.3.2.9 The inner and the outer chambers of an automatic air pipe head is to be of a minimum thickness of 6 mm. Where side covers are provided and their function is integral to providing functions of the closing device as outlined in 5.3.2.6 (P3.2.6), they shall have a minimum wall thickness of 6 mm. If the air pipe head can meet the tightness test in 5.3.4.1 b) (P3.4.1b) without the side covers attached, then the side covers are not considered to be integral to the closing device, in which case a wall less than 6 mm can be acceptable for side covers. (P3.2.9)

5.3.3 Materials (P3.3)

5.3.3.1 Casings of air pipe closing devices are to be of approved metallic materials adequately protected against corrosion. (P3.3.1)

5.3.3.2 For galvanised steel air pipe heads, the zinc coating is to be applied by the hot method and the thickness is to be 70 to 100 microns. (P3.3.2)

5.3.3.3 For areas of the head susceptible to erosion (e.g. those parts directly subjected to ballast water impact when the tank is being pressed up, for example the inner chamber area above the

air pipe, plus an overlap of 100 or more either side) an additional harder coating should be applied. This is to be an aluminium bearing epoxy, or other equivalent, coating, applied over the zinc. (P3.3.3)

5.3.3.4 Closures and seats made of non-metallic materials are to be compatible with the media intended to be carried in the tank and to seawater and suitable for operating at ambient temperatures between -25°C and 85°C. (P3.3.4)

5.3.4 Type Testing (P3.4)

5.3.4.1 Testing of Air Pipe Automatic Closing Devices (P3.4.1)

Each type and size of air pipe automatic closing device is to be surveyed and type tested at the manufacturer's works or other acceptable location according to the Classification Society's practice. The minimum test requirements for an air pipe automatic closing device are to include the following:

a) Determination of the Flow Characteristics.

The flow characteristics of the air pipe closing device are to be determined. Measuring of the pressure drop versus rate of volume flow is to be carried out using water and with any intended flame or insect screens in place.

a1) Recommended procedure for determination of air pipe closing device flow characteristics

On the test stand, the pressure drop versus rate of volume flow is determined for each nominal diameter of the air pipe closing device size range, subjected to test.

To determine the ζ value which is related to the velocity, a sufficient number of measurements are to be made with different rates of volume flow.

If the flow testing is carried out with orifice plates, the following data are to be recorded for each measuring point:

- differential pressure of the orifice,
- flow coefficient (C) of the orifice,
- Reynolds number (Re_D) related to the inner pipe diameter,
- rate of volume flow and pressure drop at the air pipe closing device.

Flow characteristics changes shall be graphically represented.

.1 General requirements

- the measuring equipment for determining mass and/or rate of volume flow shall comply with recognized standards,
- the measuring equipment shall be fitted at such points of the piping where full velocity is reached and irrotational flow exists. As a rule this requirement is met if straight piping lengths upstream and downstream the orifice plate are in accordance with the standards. The value of specific gravity and viscosity of the test medium under operating conditions should be known.
- the rate of volume flow should be constant,
- in the measuring section, the pipe shall be completely filled with the flowing fluid.

.2 Measurement of fluid flow by means of orifice plates inserted in pipe

Test stand for determining resistance coefficient (Test medium: water)

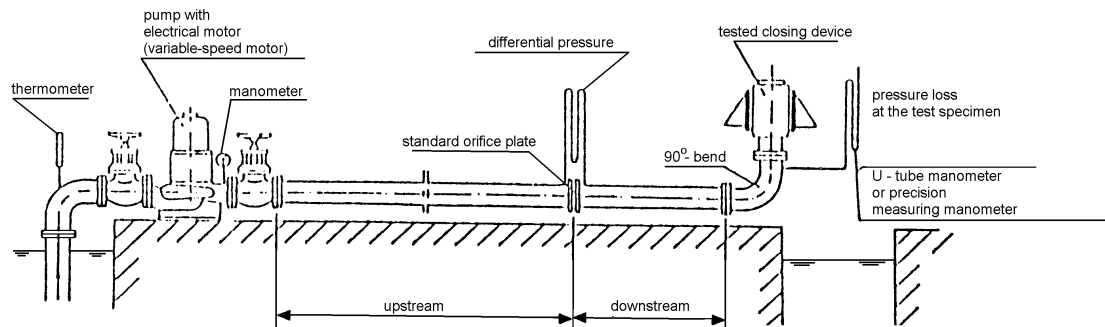

Notes to determining the ζ value.

The rate of volume flow \dot{V} [m³/s] is calculated as follows:

$$\dot{V} = m \frac{\pi}{4} D^2 \alpha \sqrt{2 \frac{\Delta p}{\rho_{H_2O}}}$$

or

$$\dot{V} = C \frac{\pi}{4} d^2 E \sqrt{2 \frac{\Delta p}{\rho_{H_2O}}}$$

Taking into account, in the above formulae, the values of tests results and introducing:

$$f = m \frac{\pi}{4} D^2 3600 \sqrt{\frac{2g}{1000} \left(\frac{\rho_{Hg}}{\rho_{H_2O}} - 1 \right)}$$

we obtain:

$$\dot{V} = f \alpha \sqrt{h}$$

or

$$\dot{V} = f C E \sqrt{h}$$

where h is given in [mm Hg].

Symbols:

D – inside diameter of piping, [m]

d – inner diameter of orifice plate, [m]

$m = \beta^2 = \frac{d^2}{D^2}$ aperture ratio, [-]

$\beta = \frac{d}{D}$ diameters ratio, [-]

$\nu = \frac{\eta}{\rho}$ kinematic viscosity, [m²/s]

ρ – specific gravity, [kg/m³]

η – absolute viscosity, [Pa·s]

α – flow coefficient of orifice plate as a function of Reynolds number, [-]

$$Re_D = \frac{D \cdot w}{\nu}$$

$w = \frac{\dot{V}}{A}$ velocity of test medium, [m/s]

A – cross-section of piping, [m²]

g – acceleration of gravity, [m/s²]

$$\Delta p = hg(\rho_{\text{Hg}} - \rho_{\text{H}_2\text{O}}) \text{ [N/m}^2\text{]}$$

h – differential pressure taken at standard orifice plate (U-tube mercury manometer), [mm Hg]

E – velocity coefficient, [-]

$$E = \frac{1}{\sqrt{1 - \beta^4}} = \frac{D^2}{\sqrt{D^4 - d^4}}$$

C – flow coefficient as a function of Reynolds number (Re_D), [-]

$$C = \frac{\alpha}{E}$$

ρ_{Hg} – the specific gravity of mercury, [kg/m³]

$\rho_{\text{H}_2\text{O}}$ – the specific gravity of water may be approximately taken equal to 1000 kg/m³.

The kinematic viscosity depending on temperature can be taken from the relevant diagrams.

The exact value of C for standard orifice plates is experimentally determined and can be taken from the relevant diagrams.

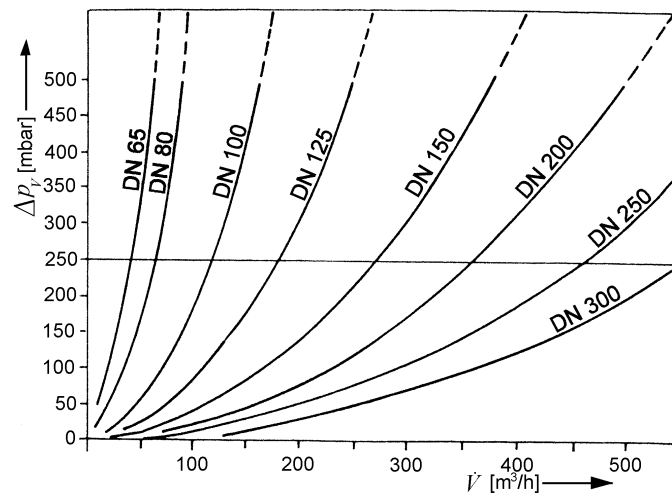

Flow resistance curves for various dimensions of the same type air pipe closing devices.

Δp_v – pressure drop at the tested closing device

\dot{V} – rate of volume flow

Where practicable, for each nominal diameter the flow resistance characteristics shall be determined experimentally. If the pump capacity is not adequate for nominal diameters exceeding DN 300, the ζ value for the air pipe closing device shall be determined by flow resistance calculations. If flow resistance curves show hydraulic analogy, the ζ value will not change, even for bigger nominal diameters. Hydraulic analogy exists if, at constant resistance head and equal velocity of flow, the rates of volume flow satisfy the ratio:

$$\frac{\dot{V}_1}{\dot{V}_2} = \frac{d_2^2}{d_1^2}$$

Note:

The ζ value is calculated for flow velocity in the connecting flange and determined for the flow resistance equal to 0.025 MPa.

.3 Calculation of flow resistance

Since air pipe closing devices can be also regarded as part of overflow pipes, it is to be ensured that the whole volume of liquid will be discharged through the air pipe device without exceeding the design pressure of the tank. To meet this requirement, the total flow resistance of air pipes and overflow pipes should be known at designing air pipe system. The total flow resistance of air pipes consists of the resistance of straight pipe lengths, the resistance of the fittings and valves and is expressed in terms of pressure loss. Furthermore, apart from the above-mentioned resistances, the vertical differences within the system, i.e. the height of the air and overflow pipe, measured between the tanktop and the air pipe closing device, shall be taken into account in the calculations.

Flow resistance components:

I

$$\Delta p_v = \lambda \frac{l}{d} \frac{w^2}{2} \rho$$

II

$$\Delta p_v = \zeta \cdot \frac{w^2}{2} \cdot \rho$$

III

$$\Delta p_v = H \cdot g \cdot \rho$$

where:

- Δp_v – pressure loss, [N/m²]
- l – length of straight pipe, [m]
- λ, ζ – resistance coefficients, [-]
- H – vertical difference, [m]
- I – for straight pipe lengths
- II – for fittings and valves
- III – for vertical differences

The sum of pressure losses (I, II, III) cannot exceed the tank design pressure.

b) Tightness test during immersion/emerging in water.

An automatic closing device is to be subjected to a series of tightness tests involving not less than two (2) immersion cycles under each of the following conditions:

- i) The automatic closing device is to be submerged slightly below the water surface at a velocity of approximately 4 m/min and then returned to the original position immediately. The quantity of leakage is to be recorded.
- ii) The automatic closing device is to be submerged to a point slightly below the surface of the water. The submerging velocity is to be approximately 8 m/min and the air pipe vent head is to remain submerged for not less than 5 minutes. The quantity of leakage shall be recorded.
- iii) Each of the above tightness tests shall be carried out in the normal position as well as at an inclination of 40 degrees under the strictest conditions for the device. In cases where such strictest conditions are not clear, tests shall be carried out at an inclination of 40 degrees

with the device opening facing in three different directions: upward, downward, sideways (left or right). (See Figure 1 to 4).

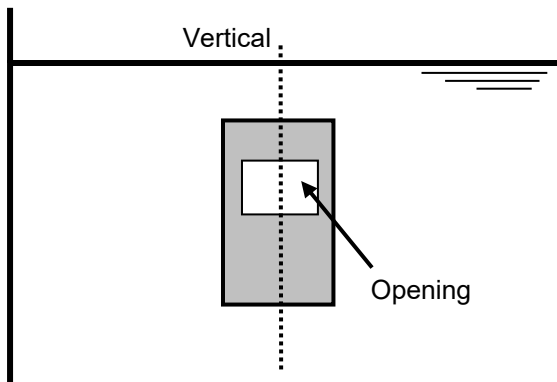

Fig 1: Example of normal position

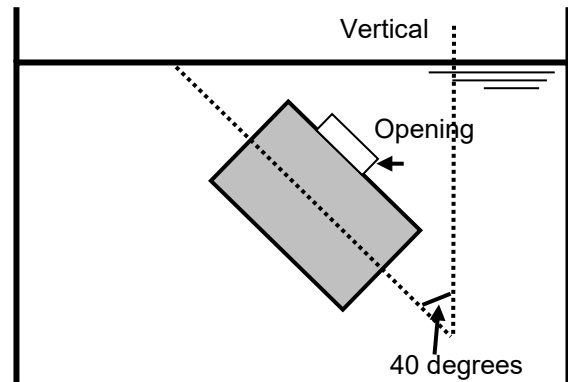

Fig 2: Example of inclination 40 degrees opening facing upward

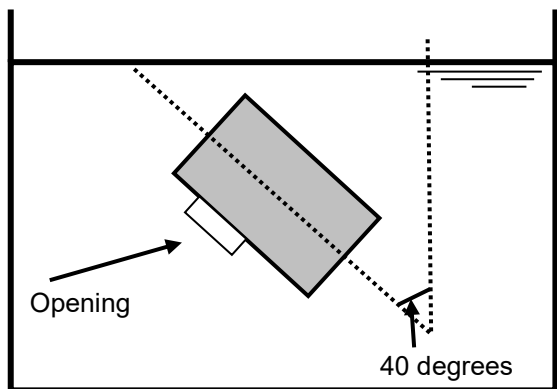

Fig 3: Example of inclination 40 degrees opening facing downward

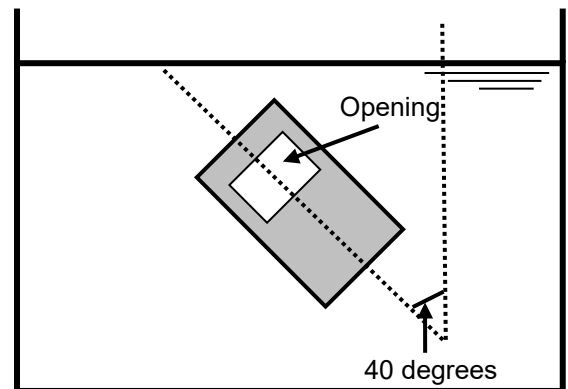

Fig 4: Example of inclination 40 degrees opening facing sideways

The maximum allowable leakage per cycle shall not exceed 2 ml/mm of nominal diameter of inlet pipe during any individual test.

c) Discharge / Reverse flow test

The air pipe head shall allow the passage of air to prevent excessive vacuum developing in the tank.

i) Reverse flow test

- 1) A reverse flow test shall be performed. A vacuum pump or another suitable device shall be connected to the opening of the air pipe leading to the tank. The flow velocity shall be applied gradually at a constant rate until the float gets sucked and blocks the flow; and
- 2) The velocity at the point of blocking shall be recorded. 80% of the value recorded will be stated in the certificate.

ii) Alternative to the reverse flow test

- 1) For pipe heads of 400 mm nominal diameter and above, as an alternative to the reverse flow test, a numerical simulation test based on computational fluid dynamics (CFD), to be carried out in conjunction with limited representative testing to establish the validity of the CFD modelling and results, may be accepted;

- 2) CFD predictions for air pipe heads can be validated against the available actual reverse flow test results of same size and type of air pipe heads;
- 3) The accuracy of the CFD modelling and the major assumptions used for the calculation are to be documented;
- 4) Mesh convergence studies are to be carried out and documented; and
- 5) The requirement as per the preceding i) 2) applies.

5.3.4.2 Testing of non-metallic Floats (P3.4.2)

Impact and compression loading tests shall be carried out on the floats before and after pre-conditioning as follows:

Test temperature °C	-25	20	85
Test condition			
Dry	+	+	+
After immersing in water	+	+	+
After immersing in fuel oil	-	+	-
Immersing in water and fuel oil is to be for at least 48 hours			

The total period of keeping the floats at the above specified temperatures before dry test is to be at least 24 hours.

a) Impact Test

The test may be conducted on a pendulum type testing machine. The floats shall be subjected to 5 impacts of 2.5 Nm each and shall not suffer permanent deformation, cracking or surface deterioration at this impact loading.

Subsequently the floats shall be subjected to 5 impacts of 25 Nm each. At this impact energy level some localised surface damage at the impact point may occur. No permanent deformation or cracking of the floats shall appear.

b) Compression Loading Test

Compression tests shall be conducted with the floats mounted on a supporting ring of a diameter and bearing area corresponding to those of the float seating with which it is intended that float shall be used. For ball type float, loads shall be applied through a concave cap of the same internal radius as the test float and bearing on an area of the same diameter as the seating. For a disc type float, loads are to be applied through a disc of equal diameter as the float.

A load of 350 kg shall be applied over one minute and maintained for 60 minutes. The deflection shall be measured at intervals of 10 minutes after attachment of the full load. The record of deflection against time is to show no continuing increase in deflection and, after release of the load, there shall be no permanent deflection.

5.3.4.3 Testing of Metallic Floats (P3.4.3)

Tests shall be conducted in accordance with 5.3.4.2a) (3.4.2a)). The tests shall be carried out at room temperature and in the dry condition.

5.3.4.4 Marking

Air pipe closing devices shall be marked with the following particulars:

- nominal diameter DN,
- resistance coefficient ζ ,

- type,
- manufacturer.

END OF IACS UR P3

5.4 Sounding pipes – general requirements

5.4.1 Tanks and situated below the load waterline cofferdams, as well as bilges and bilge wells not readily accessible, shall be fitted with sounding pipes led to the open deck or with other level indicating devices of a type approved by PRS.

5.4.2 Sounding pipes for cofferdams and tanks not forming part of the hull structure need not be led to the open deck provided they are readily accessible under all service conditions.

5.4.3 Sounding pipes of the double bottom water tanks may terminate in the spaces above the tanks if they are readily accessible. These pipes shall not be used as air pipes and shall be fitted with self-closing sounding devices (cocks).

5.4.4 Top ends of sounding pipes fitted with self-closing cocks shall terminate not less than 0.5 m above the floor level. The cocks shall be corrosion resistant and when they serve fuel oil or heated lubricating oil tanks also of a non-sparking design.

5.4.5 Where the double bottom forms wing bilges or the ship has a flat bottom, one sounding pipe shall be installed at each side of the ship. The pipes shall be led straight or with slight curvature to permit a ready passage of the sounding rod to readily accessible places above the bulkhead deck.

5.4.6 Striking plate or an equivalent arrangement protecting the bottom plating against damage shall be fitted under each open ended sounding pipe.

5.4.7 Where slotted sounding pipes having closed ends are employed, the lower ends of the pipes shall be adequately strengthened.

5.4.8 Internal diameter of sounding pipes shall not be less than 32 mm.

5.4.9 Internal diameter of sounding pipes led through refrigerated spaces where the temperature may drop to 0°C or below, as well as of the pipes of tanks fitted with heating installation, shall not be less than 50 mm. Within refrigerated spaces the pipes shall be insulated.

5.4.10 Nameplates shall be affixed to the upper ends of sounding pipes.

5.4.11 The upper ends of sounding pipes led to the open deck shall be fitted with tight plugs. The use of other closing arrangements is subject to PRS acceptance in each particular case. The plugs and threaded parts of sounding pipe deck sockets fitted in open decks shall be made of bronze, brass or stainless steel.

5.4.12 Sounding pipes terminating above the open deck level shall be so arranged as to preclude the possibility of their damage or effectively protected against damage.

5.4.13 Sounding pipes of sea water tanks and lubricating oil tanks passing through oil fuel tanks shall be led inside tight tunnels forming an integral part of the such tanks or shall be made of seamless steel pipes permanently connected. Where the use of permanent joints is impracticable, flange joints with gaskets resistant to the effect of oil fuel may be used.

5.5 Sounding pipes and arrangements for oil tanks

5.5.1 Safe and efficient means of ascertaining the amount of oil fuel contained in any oil fuel tank shall be provided. (SOLAS Reg. II-2/4.2.2.3.5)

Note:

Paragraph 5.5.1 also applies to lubricating oil and other flammable oils. (SOLAS Reg. II-2/4.2.3.1 and II-2/4.2.4).

5.5.2 Where sounding pipes are used, they shall not terminate in any space where the risk of ignition of spillage from the sounding pipe might arise. In particular, they shall not terminate in passenger or crew spaces. As a general rule, they shall not terminate in machinery spaces. However, where the Administration considers that these latter requirements are impracticable, it may permit termination of sounding pipes in machinery spaces on condition that all of the following requirements are met:

- .1 an oil-level gauge is provided meeting the requirements of 5.5.5 (paragraph 2.2.3.5.2);
- .2 the sounding pipes terminate in locations remote from ignition hazards unless precautions are taken, such as the fitting of effective screens, to prevent the oil fuel in the case of spillage through the terminations of the sounding pipes from coming into contact with a source of ignition; and
- .3 the termination of sounding pipes are fitted with self-closing blanking devices and with a small-diameter self-closing control cock located below the blanking device for the purpose of ascertaining before the blanking device is opened that oil fuel is not present. Provisions shall be made so as to ensure that any spillage of oil fuel through the control cock involves no ignition hazard. (SOLAS Reg. II-2/4.2.2.3.5.1)

Note:

Paragraph 5.5.2 also applies to lubricating oil and other flammable oils. (SOLAS Reg. II-2/4.2.3.1 and II-2/4.2.4).

5.5.3 (2) Short sounding pipes may be used for tanks other than double bottom tanks without the additional closed level gauge provided an overflow system is fitted. (IACS UR F35)

5.5.4 Self-closing blanking devices and control cocks shall meet the requirements of 5.4.4.

5.5.5 Other oil-level gauges may be used in place of sounding pipes subject to the following conditions:

- .1 in passenger ships, such gauges shall not require penetration below the top of the tank and their failure or overfilling of the tanks shall not permit release of fuel; and
- .2 in cargo ships, the failure of such gauges or overfilling of the tank shall not permit release of fuel into the space. The use of cylindrical gauge glasses is prohibited. The Administration may permit the use of oil-level gauges with flat glasses and self-closing valves between the gauges and fuel tanks. (SOLAS Reg. II-2/4.2.2.3.5.2)

Note:

Paragraph 5.5.5 also applies to lubricating oil and other flammable oils. (SOLAS Reg. II-2/4.2.3.1 and II-2/4.2.4).

5.5.6 Flat glasses shall be heat resistant to sudden temperature changes (e.g. borosilicate glass, thermal shock resistant min ΔT 200 K acc. to DIN 7080/7081) or plastic not losing its transparency in contact with oil fuel. Self-closing valves between the indicator and tank shall be fitted at the lower and upper end.

5.5.7 Level switches may be used below the tank top provided they are contained in a steel enclosure or other enclosures not capable of being destroyed by fire. (3) (IACS UR F35)

Note:

Above paragraph applies to level switches/sensors installed on oil fuel, lubricating oil, hydraulic oil, heating oil or other flammable oil tanks.

5.5.8 The arrangements for the storage, distribution and utilization of oil used in pressure lubrication systems shall be such as to ensure the safety of the ship and persons on board. The arrangements made in machinery spaces of category A, and whenever practicable in other machinery spaces, shall at least comply with the provisions of 5.5.1, 5.5.2 and 5.5.5 (paragraphs (...) 2.2.3.5 (...)), except that:

- .1 this does not preclude the use of sight-flow glasses in lubricating systems provided that they are shown by testing to have a suitable degree of fire resistance; and
- .2 sounding pipes may be authorized in machinery spaces; however, the requirements of 5.5.2.1 and 5.5.2.3 (paragraphs 2.2.3.5.1.1 and 2.2.3.5.1.3) need not be applied on condition that the sounding pipes are fitted with appropriate means of closure. (SOLAS Reg. II-2/4.2.3.1)

5.5.9 In the case of flammable oil tanks which are situated outside the machinery spaces of category A which are located above the load waterline and where there are no sources of ignition such as internal combustion engines or boilers, the use of cylindrical level indicator glasses is permitted.

In the case of tanks with the capacity less than 100 dm³, situated in machinery spaces, PRS may consider acceptance of cylindrical level indicator glasses.

CHAPTER 6

6 EXHAUST GAS SYSTEMS

6.1 Exhaust gas lines

6.1.1 Exhaust gas lines shall terminate on the open deck.

6.1.2 Where exhaust gas lines with water injection are led through the shell plating, near or below the load waterline, means shall be provided to prevent the sea-water from entering the engine. The pipes shall be looped or fitted with a suitable device such as a riser to prevent the return of water to the engine. Water for cooling exhaust gas shall be injected in a manner that minimizes the possibility of cooling water entering the engine through the exhaust manifold. Where a shut-off valve is fitted at the overboard discharge, means shall be provided to prevent the engine from being started when the valve is not fully open. Moreover this valve is to be readily operable from accessible position.

6.1.3 In ships intended for the carriage of dangerous goods with the flash point below 60°C as well as in ships intended for the carriage of timber, the exhaust gas lines of main and auxiliary engines, boilers, incinerators and galley stoves shall be fitted with the devices for smothering sparks (spark arresters) of type approved by PRS. The type approval tests shall be performed in accordance with approval procedure agreed with PRS.

Alternatively the pipes may be led overboard through the shell plating, provided that the outlet is arranged at least 0.3 m below the light waterline.

6.1.4 Exhaust gas lines and oil fuel tanks shall be not less than 450 mm apart.

6.1.5 The engines' exhaust gas lines shall be fitted with silencers whose construction is subject to PRS acceptance in each particular case.

6.1.6 Each main internal combustion engine shall be fitted with an individual exhaust line while the exhaust gas pipes of auxiliary engines may be connected to a common exhaust line, provided reliable measures are taken to prevent:

- exhaust gas from the common exhaust line from entering the engines which are not in operation,
- damage to any of the engines when starting.

In ships of restricted service receiving in their symbol of class additional mark **II** or **III**, exhaust gas pipes of main and auxiliary engines may be connected to a common exhaust line, provided safety measures as mentioned above are taken.

6.1.7 In exhaust gas boilers, as well as in boilers with combined heating which, due to their construction, cannot be left without water when heated with exhaust gas, provision shall be made for a by-pass with dampers for complete cut-off of the boilers from the exhaust gas lines.

6.1.8 The exhaust gas lines of internal combustion engines, boilers and incinerators shall be thermally insulated with suitable insulating material, or by means of double walls or shielding in accordance with the requirements specified in 1.11.

6.1.9 Where the exhaust gas lines of main and auxiliary boilers are connected, it is permitted to provide dampers fitted with locking devices keeping the dampers in the open position.

In places, where it deems necessary, manholes and inspection doors shall be provided to enable inspection and cleaning of the exhaust gas lines and air ducts.

6.1.10 The exhaust gas lines of auxiliary engines provided with remote and automatic starting shall be provided with permanent drainage arrangements preventing water from entering the engine. These arrangements shall be situated in readily accessible places and measures to enable cleaning thereof shall be taken.

Internal diameter of the drain pipes shall not be less than 25 mm.

6.1.11 Exhaust pipes shall be so designed that any expansion does not cause abnormal stresses in the piping system, and in particular in the connection with engine turbocharger(s).

6.1.12 The devices used for supporting the pipes are to allow their expansion (see also 1.10.14).

6.2 Spark arresters and silencers

6.2.1 Spark arresters shall be so located as to enable their cleaning. For this purpose, cleanouts, drain cocks or plugs shall be provided.

6.2.2 Where exhaust gas boilers and wet type spark arresters are installed, measures shall be taken to prevent water from entering the engine in the case of boiler pipes leakage or due to any other damage. The drain pipes shall be led to the engine room bilges and fitted with hydraulic seals.

6.2.3 Silencers shall be provided with cleanouts for periodical cleaning and internal inspection.

6.3 Exhaust gas cleaning systems

Ships engaged on voyages within the SECA (special emission control area) and not using low-sulphur fuel oil shall be fitted with the EGC (exhaust gas cleaning) unit to reduce the SO_x emissions. The EGC unit is subject to the approval by PRS under the authority of the Flag State Administration. Requirements for the approval are provided in *Publication 78/P – Guidelines for Exhaust Gas-SO_x Cleaning Systems*.

6.4 Storage and use of SCR reductants

IACS UR M77

6.4.1 General (1.)

The *NO_x Technical Code*, in 2.2.5 and elsewhere, provides for the use of NO_x Reducing Devices of which Selective Catalytic Reduction (SCR) is one option. SCR requires the use of a reductant which may be a urea/water solution or, in exceptional cases, aqueous ammonia or even anhydrous ammonia. These requirements apply to the arrangements for the storage and use of SCR reductants.

The requirements for SCR reductants tanks with volume below of 500 L are left to the discretion of individual Classification Societies. This discretion is only applicable to Section 2 of this UR.

6.4.2 Reductant using urea based ammonia (e.g. 40%/60% urea/water solution) (2.)

6.4.2.1 Where urea based ammonia (e.g. AUS 40 – aqueous urea solution specified in ISO 18611-1:2014) is introduced, the storage tank is to be arranged so that any leakage will be contained and prevented from making contact with heated surfaces. All pipes or other tank penetrations are to be provided with manual closing valves attached to the tank. Tank and piping arrangements are to be approved. (2.1)

6.4.2.2 The storage tank may be located within the engine room. (2.2)

6.4.2.3 The storage tank is to be protected from excessively high or low temperatures applicable to the particular concentration of the solution. Depending on the operational area of the ship, this may necessitate the fitting of heating and/or cooling systems. The physical conditions recommended by applicable recognized standards (such as ISO 18611-3:2014) are to be taken into account to ensure that the contents of the aqueous urea tank are maintained to avoid any impairment of the urea solution during storage. (2.3)

6.4.2.4 If a urea storage tank is installed in a closed compartment, the area is to be served by an effective mechanical ventilation system of extraction type providing not less than 6 air changes per hour which is independent from the ventilation system of accommodation, service spaces, or control stations. The ventilation system is to be capable of being controlled from outside the compartment. A warning notice requiring the use of such ventilation before entering the compartment shall be provided outside the compartment adjacent to each point of entry.

Alternatively, where a urea storage tank is located within an engine room a separate ventilation system is not required when the general ventilation system for the space is arranged so as to provide an effective movement of air in the vicinity of the storage tank and is to be maintained in operation continuously except when the storage tank is empty and has been thoroughly ventilated. (2.4)

6.4.2.5 Each urea storage tank is to be provided with temperature and level monitoring arrangements. High and low level alarms together with high and low temperature alarms are also to be provided. (2.5)

6.4.2.6 Where urea based ammonia solution is stored in integral tanks, the following are to be considered during the design and construction:

- These tanks may be designed and constructed as integral part of the hull, (e.g. double bottom, wing tanks).
- These tanks are to be coated with appropriate anti-corrosion coating and cannot be located adjacent to any fuel oil and fresh water tank.
- These tanks are to be designed and constructed as per the structural requirements applicable to hull and primary support members for a deep tank construction.
- These tanks are to be included in the ship's stability calculation. (2.6)

6.4.2.7 The requirements specified in 6.4.2.4 (M77.2.4) also apply to closed compartments normally entered by persons:

- when they are adjacent to the urea integral tanks and there are possible leak points (e.g. manhole, fittings) from these tanks; or
- when the urea piping systems pass through these compartments, unless the piping system is made of steel or other equivalent material with melting point above 925 degrees C and with fully welded joints. (2.7)

6.4.2.8 The reductant piping and venting systems are to be independent of other ship service piping and/or systems. Reductant piping systems are not to be located in accommodation, service spaces, or control stations. The vent pipes of the storage tank are to terminate in a safe location on the weather deck and the tank venting system is to be arranged to prevent entrance of water into the urea tank. (2.8)

6.4.2.9 Reductant tanks are to be of steel or other equivalent material* with a melting point above 925 degrees C.

Pipes/piping systems are to be of steel or other equivalent material with melting point above 925 degrees C, except downstream of the tank valve, provided this valve is metal seated and arranged as fail-to-closed or with quick closing from a safe position outside the space in the event of fire; in such case, type approved plastic piping may be accepted even if it has not passed a fire endurance test. Reductant tanks and pipes/piping systems are to be made with a material compatible with reductant or coated with appropriate anti-corrosion coating. (2.9)

* Footnote to 2.9: Material requirement “to be of steel or other equivalent material” in the first paragraph with a melting point above 925 degrees C is not applicable for integral tanks on FRP vessels such as those listed below, provided that the integral tanks are coated and/or insulated with a self-extinguishing material.

- 1) FRP vessels complying with Regulation 17 of SOLAS Chapter II-2 based upon its associated IMO guidelines (MSC.1/Circ.1574), and
- 2) FRP vessels exempted from the application of SOLAS e.g., yachts, fast patrol, navy vessels, etc., generally of less than 500 gross tonnage, subject to yacht codes or flag regulations.

6.4.2.10 For the protection of crew members, the ship is to have on board suitable personnel protective equipment. Eyewash are to be provided, the location and number of these eyewash stations are to be derived from the detailed installation arrangements. (2.10)

6.4.2.11 Urea storage tanks are to be arranged so that they can be emptied of urea and ventilated by means of portable or permanent systems. (2.11)

6.4.3 Reductant using aqueous ammonia (28% or less concentration of ammonia) (3.)

Aqueous ammonia is not to be used as a reductant in a SCR except where it can be demonstrated that it is not practicable to use a urea based reductant. Where an application is made to use aqueous ammonia as the reductant then the arrangements for its loading, carriage and use are to be derived from a risk based analysis.

6.4.4 Reductant using anhydrous ammonia (99.5% or greater concentration of ammonia by weight) (4.)

Anhydrous ammonia is not to be used as a reductant in a SCR except where it can be demonstrated that it is not practicable to use a urea based reductant and where the Flag Administration agrees to its use. Where it is not practicable to use a urea reductant then it is also to be demonstrated that it is not practicable to use aqueous ammonia. Where an application is made to use anhydrous ammonia as the reductant then the arrangements for its loading, carriage and use are to be derived from a risk based analysis.

END OF IACS UR M77

6.5 Safety measures against chemical treatment fluids used for exhaust gas cleaning systems and the residues which have hazardous properties

IACS UR M81

6.5.1 General (1.)

6.5.1.1 With regard to regulation 14 of MARPOL Annex VI requiring ships to use fuel oil with a sulphur content not exceeding that stipulated in regulations 14.1 or 14.4, regulation 4 allows, with the approval of the Administration, the use of an alternative compliance method at least as effective in terms of emission reductions as that required by the MARPOL Annex VI, including the standards set forth in regulation 14. (1.1)

6.5.1.2 As some types of exhaust gas cleaning systems to be approved by the Administration as “alternative compliance method” consume chemicals which are typically carried on board in bulk quantities, the prescriptive requirements contained in this UR related safety measures against chemical treatment fluids apply to exhaust gas cleaning systems using such fluids. In this context, the term “chemical treatment fluid” means the aqueous solution of sodium hydroxide (NaOH) or calcium hydroxide (Ca(OH)₂) that has corrosive properties or are considered to represent a hazard to personnel – see 6.5.2 (See section 2 of this UR). (1.2)

6.5.1.3 For exhaust gas cleaning systems using chemicals other than the above, safety measures are to be taken according to the result of a risk assessment to be conducted to analyze the risks, in order to eliminate or mitigate the hazards to personnel brought by the use of such exhaust gas cleaning systems, to an extent equivalent to systems complying with 6.5.2.1 to 6.5.2.16 (M81 2.1 to M81 2.16). (1.3)

6.5.2 Requirements for exhaust gas cleaning systems using aqueous solution of NaOH or Ca(OH)₂ for chemical treatment fluid (2.)

6.5.2.1 The storage tank for chemical treatment fluids is to be arranged so that any leakage will be contained and prevented from making contact with heated surfaces. All pipes or other tank penetrations are to be provided with manual closing valves attached to the tank. In cases where such valves are provided below top of tank, they are to be arranged with quick acting shutoff valves which are to be capable of being remotely operated from a position accessible even in the event of chemical treatment fluid leakages. Tank and piping arrangements are to be approved. (2.1)

6.5.2.2 The storage tank is to be protected from excessively high or low temperatures applicable to the particular concentration chemical treatment fluids. Depending on the operational area of the ship, this may necessitate the fitting of heating and/or cooling systems. (2.2)

6.5.2.3 If a storage tank for chemical treatment fluids is installed in a closed compartment, the area is to be served by an effective mechanical ventilation system of extraction type providing not less than 6 air changes per hour which is independent from the ventilation system of other spaces. The ventilation system is to be capable of being controlled from outside the compartment. A warning notice requiring the use of such ventilation before entering the compartment shall be provided outside the compartment adjacent to each point of entry. (2.3)

6.5.2.4 The storage tank may be located within the engine room. In this case, the requirements of 2.3 shall be complied with, except that a separate ventilation system is not required when the general ventilation system for the space is arranged so as to provide an effective movement of air in the vicinity of the storage tank and is maintained in operation continuously except when the storage tank is empty and has been thoroughly ventilated. (2.4)

6.5.2.5 Each storage tank for chemical treatment fluids is to be provided with level monitoring arrangements and high/low level alarms. In cases where heating and/or cooling systems are provided, high and/or low temperature alarms or temperature monitoring are also to be provided accordingly. (2.5)

6.5.2.6 The storage tanks are to have sufficient strength to withstand a pressure corresponding to the maximum height of a fluid column in the overflow pipe, with a minimum of 2.4 m above the top plate taking into consideration the specific density of the treatment fluid. (2.6)

6.5.2.7 Where chemical treatment fluid is stored in integral tanks, the following are to be considered during the design and construction:

- .1 These tanks may be designed and constructed as integral part of the hull, (e.g. double bottom, wing tanks).
- .2 These tanks are to be coated with appropriate anti-corrosion coating and are to be segregated by cofferdams, void spaces, pump rooms, empty tanks or other similar spaces so as to not be located adjacent to accommodation, cargo spaces containing cargoes which react with chemical treatment fluids in a hazardous manner as well as any food stores, oil tanks and fresh water tanks.
- .3 These tanks are to be designed and constructed as per the structural requirements applicable to hull and primary support members for a deep tank construction.
- .4 These tanks are to be included in the ship's stability calculation. (2.7)

6.5.2.8 The requirements specified in 6.5.2.3 (M81 2.3) also apply to closed compartments normally entered by persons:

- .1 when they are adjacent to the integral storage tank for chemical treatment fluids and there are possible leak points (e.g. manhole, fittings) from these tanks; or
- .2 when the treatment fluid piping systems pass through these compartments, unless the piping system is made of steel or other equivalent material with melting point above 925 degrees C and with fully welded joints. (2.8)

6.5.2.9 The chemical treatment fluid piping and venting systems are to be independent of other ship service piping and/or systems. The chemical treatment fluid piping systems are not to be located in accommodation, service spaces, or control stations. The vent pipes of the storage tank are to terminate in a safe location on the weather deck and the tank venting system is to be arranged to prevent entrance of water into the tank for chemical treatment fluids. (2.9)

6.5.2.10 Storage tanks and pipes/piping systems **and drip trays** for chemical treatment fluids which transfer undiluted chemical treatment fluids are to be of steel or other equivalent material with a melting point above 925 degrees C. (2.10)

6.5.2.11 Storage tanks and pipes/piping systems for chemical treatment fluids are to be made with a material compatible with chemical treatment fluids, or coated with appropriate anticorrosion coating. (2.11)

Footnote:

Several metals are incompatible with the chemical treatment fluids, e.g. NaOH is incompatible with zinc, aluminum, etc.

6.5.2.12 Regardless of design pressure and temperature, piping systems containing chemical treatment fluids only are to comply with the requirements applicable to Class I piping systems (see 1.6.2). As far as practicable, e.g. except for the flange connections that connect to tank valves, the piping systems are to be joined by welding. (2.12)

6.5.2.13 The following connections are to be screened and fitted with drip trays to prevent the spread of any spillage where they are installed:

- .1 Detachable connections between pipes (flanged connections and mechanical joints, etc.);
- .2 Detachable connections between pipes and equipment such as pumps, strainers, heaters, valves; and
- .3 Detachable connections between equipment mentioned in the above subparagraph.

The drip trays are to be fitted with drain pipes which lead to appropriate tanks, such as residue tanks, which are fitted with high level alarm, or are to be fitted with alarms for leak detection. In

cases where such tank is an integral tank, 6.5.2.7.1 and 6.5.2.7.2 (M81 2.7.1 and M81 2.7.2) are to be applied to the tank. (2.13)

6.5.2.14 For the protection of crew members, the ship is to have on board suitable personnel protective equipment. The number of personnel protective equipment carried onboard is to be appropriate for the number of personnel engaged in regular handling operations or that may be exposed in the event of a failure; but in no case is there to be less than two sets available onboard. (2.14)

6.5.2.15 Personnel protective equipment is to consist of protective clothing, boots, gloves and tight-fitting goggles.

Eyewash and safety showers are to be provided, the location and number of these eyewash stations and safety showers are to be derived from the detailed installation arrangements. As a minimum, the following stations are to be provided:

- .1 In the vicinity of transfer or treatment pump locations. If there are multiple transfer or treatment pump locations on the same deck then one eyewash and safety shower station may be considered for acceptance provided that the station is easily accessible from all such pump locations on the same deck.
- .2 An eyewash station and safety shower is to be provided in the vicinity of a chemical bunkering station on-deck. If the bunkering connections are located on both port and starboard sides, then consideration is to be given to providing two eyewash stations and safety showers, one for each side.
- .3 An eyewash station and safety shower is to be provided in the vicinity of any part of the system where a spillage/drainage may occur and in the vicinity of system connections/components that require periodic maintenance. (2.15)

6.5.2.16 Storage tanks for chemical treatment fluids are to be arranged so that they can be emptied of the fluids and ventilated by means of portable or permanent systems. (2.16)

6.5.3 Requirement for Exhaust Gas Cleaning Systems discharge water pipeline (3.)

6.5.3.1 Overboard discharges from exhaust gas cleaning system (EGCS) are not to be interconnected to other systems. (3.1)

6.5.3.2 Due consideration is to be given to the location of overboard discharges with respect to vessel propulsion features, such as thrusters, propellers or to prevent any discharge water onto survival craft during abandonment. (3.2)

6.5.3.3 The piping material for the EGCS discharge water pipeline system is to be selected based on the corrosive nature of the liquid media. (3.3)

6.5.3.4 Special attention is to be paid to the corrosion resistivity of EGCS overboard discharge piping. Where applicable, adequate arrangements are to be provided to prevent galvanic corrosion due to the use of dissimilar metals. (3.4)

6.5.3.5 In case distance piece is fitted between the outboard discharge valve and the shell plating, it shall be made of corrosion resistant material steel or be coated with an anti-corrosive material suitable for the operating environment. The thickness of the distance piece shall be at least the minimum values specified in .1 and .2 as below; otherwise Sch.160 thickness specified in piping standards shall, as far as practicable, be used.

- .1 12 mm in cases where complete pipe is made of corrosion resistant material steel.

.2 15 mm of mild steel in cases where the inside the pipe is treated with an anticorrosive coating or fitted with a sleeve of corrosion resistant material. (3.5)

6.5.4 Miscellaneous (4.)

6.5.4.1 Tanks for residues generated from the exhaust gas cleaning process are to satisfy the following requirements:

- .1 The tanks are to be independent from other tanks, except in cases where these tanks are also used as the over flow tanks for chemical treatment fluids storage tank.
- .2 Tank capacities are to be decided in consideration of the number and kinds of installed exhaust gas cleaning systems as well as the maximum number of days between ports where residue can be discharged ashore. In the absence of precise data, a figure of 30 days is to be used.
- .3 Where residue tanks used in closed loop chemical treatment systems are also used as the overflow tanks for chemical treatment fluids storage tank, the requirements for storage tanks apply. (4.1)

END OF IACS UR M81

CHAPTER 7

7 VENTILATION SYSTEMS

7.1 General requirements

7.1.1 Ventilation ducts passing through watertight bulkheads and decks shall not impair watertight integrity of the ship. They shall be watertight, have sufficient strength and meet applicable requirements specified in 1.8 and in *Part II*, 9.5.3.

7.1.2 Considering the fumigation of cargo holds and related risk of fumigant leakage into other enclosed spaces where people can work or live, ventilation ducts serving cargo holds shall not have shared structural elements (e.g. common divisions) with ventilation ducts serving the other spaces.

7.1.3 In places where moisture condensation may occur, ventilation ducts shall be insulated. The sections of ventilation ducts where water may condense shall be fitted with drain plugs.

7.1.4 Ventilation ducts (ventilators) above the freeboard deck, their coamings and closing arrangements shall be such as to prevent water ingress into the ship. They shall have sufficient strength and meet applicable requirements specified in *Part II*, 8.6.4 and *Part III*, 7.6 and 7.7.

7.1.5 Ventilation inlets (air intakes) and outlets located on open decks shall be so spaced and arranged that in the event of fire the smoke coming out through any ventilation outlet will not be drawn by any ventilation inlet.

7.1.6 Air intakes to ventilation systems serving ship spaces shall be located at a suitable distance from the outlets of fuel and oil tanks vents and shall be so arranged as to preclude the possibility of oil products vapours penetration, through ventilation ducts, to these spaces.

7.1.7 Ventilation ducts passing through fire divisions shall not impair fire resistance of the divisions they pierce. They shall meet applicable requirements specified in 1.9 and 7.2 to 7.4.

7.1.8 When designing ventilation systems for ships with length L of 100 m or more, the relevant requirements specified in *Part IV* shall also be fulfilled.

7.1.9 Electric drives for fans shall meet the requirements specified in *Part VIII*, 5.7.

7.2 Ducts, dampers, penetrations – fire considerations

7.2.1 Ventilation ducts, including single and double wall ducts, shall be of steel or equivalent material** except flexible bellows of short length not exceeding 600 mm used for connecting fans to the ducting in air-conditioning rooms. Unless expressly provided otherwise in 7.2.6 (paragraph 7.1.6), any other material used in the construction of ducts, including insulation, shall also be non-combustible. However, short ducts, not generally exceeding 2 m in length and with a free cross-sectional area* not exceeding 0.02 m², need not be of steel or equivalent material, subject to the following conditions:

**** IACS and IMO interpretation**

With respect to 7.2.1 (SOLAS II-2/9.7.1.1), a ventilation duct made of material other than steel may be considered equivalent to a ventilation duct made of steel, provided the material is non-combustible and has passed a standard fire test in accordance with Annex 1: Part 3 of the FTP Code as non-load bearing structure for 30 minutes following the requirements for testing "B" class divisions. (IACS UI SC264, MSC.1/Circ.1527)

* The term *free cross-sectional area* means, even in the case of a pre-insulated duct, the area calculated on the basis of the inner dimensions of the duct itself and not the insulation. (MSC/Circ.1120)

- .1 the ducts shall be made of non-combustible material, which may be faced internally and externally with membranes having low flame-spread characteristics and, in each case, a calorific value** not exceeding 45 MJ/m² of their surface area for the thickness used;

** Refer to the recommendations published by the International Organization for Standardization, in particular publication ISO 1716:2002*, *Reaction to the fire tests for building products – Determination of the heat of combustion*.

Note:

* According to *FTP Code*: Whenever a reference is made to ISO or IEC standards, the year of publication should be understood as specified below: (...) .3 ISO 1716:2010 (...)

- .2 the ducts are only used at the end of the ventilation device; and
- .3 the ducts are not situated less than 600 mm, measured along the duct, from an opening in an "A" or "B" class division, including continuous "B" class ceiling. (SOLAS Reg. II-2/9.7.1.1)

7.2.2 The following arrangements shall be tested in accordance with the *Fire Test Procedures Code*:

- .1 fire dampers, including their relevant means of operation, however, the testing is not required for dampers located at the lower end of the duct in exhaust ducts for galley ranges, which must be of steel and capable of stopping the draught in the duct; and
- .2 duct penetrations through "A" class divisions. However, the test is not required where steel sleeves are directly joined to ventilation ducts by means of riveted or screwed connections or by welding. (SOLAS Reg. II-2/9.7.1.2)

Note:

See also 1.4.6 and 1.9.1.

7.2.3 Fire dampers shall be easily accessible. Where they are placed behind ceilings or linings, these ceilings or linings shall be provided with an inspection hatch on which the identification number of the fire damper is marked. The fire damper identification number shall also be marked on any remote controls provided. (SOLAS Reg. II-2/9.7.1.3)

7.2.4 Ventilation ducts shall be provided with hatches for inspection and cleaning. The hatches shall be located near the fire dampers. (SOLAS Reg. II-2/9.7.1.4)

7.2.5 The main inlets and outlets of ventilation systems shall be capable of being closed from outside the spaces being ventilated. The means of closing shall be easily accessible as well as prominently and permanently marked and shall indicate the operating position of the closing device. (SOLAS Reg. II-2/9.7.1.5)

7.2.6 Combustible gaskets in flanged ventilation duct connections are not permitted within 600 mm of openings in "A" or "B" class divisions and in ducts required to be of "A" class construction. (SOLAS Reg. II-2/9.7.1.6)

Note:

IACS UI SC175 is technically identical with the present Reg. II-2/9.7.1.6, hence the UI is not repeated.

7.2.7 Ventilation openings or air balance ducts between two enclosed spaces shall not be provided except as permitted by *Part V*, 11.1.3.2.1 and 2.2.7.1.3 (paragraphs 4.1.2.1 and 4.2.3). (SOLAS Reg. II-2/9.7.2.7)

7.3 Separation of ventilation systems, ducts passage through various spaces

Note:

Additional or specific requirements for passenger ships – see 17.1.5.

7.3.1 The ventilation systems for machinery spaces of category A, vehicle spaces, ro-ro spaces, galleys, special category spaces and cargo spaces shall, in general, be separated from each other and from the ventilation systems serving other spaces. However, the galley ventilation systems on cargo ships of less than 4,000 gross tonnage and in passenger ships carrying not more than 36 passengers need not be completely separated from other ventilation systems, but may be served by separate ducts from a ventilation unit serving other spaces. In such a case, an automatic fire damper shall be fitted in the galley ventilation duct near the ventilation unit. (SOLAS Reg. II-2/9.7.2.1)

7.3.2 Ducts provided for the ventilation of machinery spaces of category A, galleys, vehicle spaces, ro-ro spaces or special category spaces shall not pass through accommodation spaces, service spaces, or control stations unless they comply with 7.3.4 (paragraph 7.2.4). (SOLAS Reg. II-2/9.7.2.2)

7.3.3 Ducts provided for the ventilation of accommodation spaces, service spaces or control stations shall not pass through machinery spaces of category A, galleys, vehicle spaces, ro-ro spaces or special category spaces unless they comply with 7.3.4 (paragraph 7.2.4). (SOLAS Reg. II-2/9.7.2.3)

7.3.4 As permitted by 7.3.2 and 7.3.3 (paragraphs 7.2.2 and 7.2.3) ducts shall be either:

- 1.1** constructed of steel having a thickness of at least 3 mm for ducts with a free cross-sectional area of less than 0.075 m², at least 4 mm for ducts with a free cross-sectional area of between 0.075 m² and 0.45 m², and at least 5 mm for ducts with a free cross-sectional area of over 0.45 m²;
 - 1.2** suitably supported and stiffened;
 - 1.3** fitted with automatic fire dampers close to the boundaries penetrated; and
 - 1.4** insulated to "A-60" class standard from the boundaries of the spaces they serve to a point at least 5 m beyond each fire damper;
- or
- 2.1** constructed of steel in accordance with 7.3.4.1.1 and 7.3.4.1.2 (paragraphs 7.2.4.1.1 and 7.2.4.1.2); and
 - 2.2** insulated to "A-60" class standard throughout the spaces they pass through, except for ducts that pass through spaces of category (9) or (10) as defined in paragraph 2.2.3.2.2 (see *Part V*, 11.1.2.3). (SOLAS Reg. II-2/9.7.2.4)

7.3.5 For the purposes of 7.3.4.1.4 and 7.3.4.2.2 (paragraphs 7.2.4.1.4 and 7.2.4.2.2), ducts shall be insulated over their entire cross-sectional external surface. Ducts that are outside but adjacent to the specified space, and share one or more surfaces with it, shall be considered to pass through the specified space, and shall be insulated over the surface they share with the space for a distance of 450 mm past the duct*. (SOLAS Reg. II-2/9.7.2.5)

* Sketches of such arrangements are contained in the Unified Interpretations of SOLAS Chapter II-2 (MSC.1/Circ.1276).

7.3.6 Where it is necessary that a ventilation duct passes through a main vertical zone division, an automatic fire damper shall be fitted adjacent to the division. The damper shall also be capable of being manually closed from each side of the division. The control location shall be readily accessible and be clearly and prominently marked. The duct between the division and the damper shall be constructed of steel in accordance with 7.3.4.1.1 and 7.3.4.1.2 (paragraphs 7.2.4.1.1 and 7.2.4.1.2) and insulated to at least the same fire integrity as the division penetrated. The damper shall be fitted on at least one side of the division with a visible indicator showing the operating position of the damper. (SOLAS Reg. II-2/9.7.2.6)

7.3.7 Ventilation ducts intended for the extraction of explosive or flammable vapours or gases shall not pass through the explosion-hazardous spaces, unless led in gastight tunnels.

7.3.8 Air ducts passing through refrigerated spaces shall be gastight and well insulated.

7.4 Details of fire dampers and duct penetrations in fire divisions

7.4.1 Ducts passing through “A” class divisions shall meet the following requirements:

- .1** where a thin plated duct with a free cross sectional area equal to, or less than, 0.02 m² passes through “A” class divisions, the opening shall be fitted with a steel sheet sleeve having a thickness of at least 3 mm and a length of at least 200 mm, divided preferably into 100 mm on each side of a bulkhead or, in the case of a deck, wholly laid on the lower side of the decks penetrated;
- .2** where ventilation ducts with a free cross-sectional area exceeding 0.02 m², but not more than 0.075 m², pass through “A” class divisions, the openings shall be lined with steel sheet sleeves. The ducts and sleeves shall have a thickness of at least 3 mm and a length of at least 900 mm. When passing through bulkheads, this length shall be divided preferably into 450 mm on each side of the bulkhead. These ducts, or sleeves lining such ducts, shall be provided with fire insulation*. The insulation shall have at least the same fire integrity as the division through which the duct passes; and

*** IACS and IMO interpretation**

The fire insulation required by .2 (regulation SOLAS II-2/9.7.3.1.2) should be provided only to the part of the duct and/or sleeve that is on the same side of the division being fire insulated, and be extended for a minimum of 450 mm along the duct and/or sleeve. (IACS UI SC300, MSC.1/Circ.1655)

- .3** automatic fire dampers** shall be fitted in all ducts with a free cross-sectional area exceeding 0.075 m² that pass through “A” class divisions. Each damper shall be fitted close to the division penetrated and the duct between the damper and the division penetrated shall be constructed of steel in accordance with 7.3.4.2.1 and 7.3.4.2.2 (paragraphs 7.2.4.2.1 and 7.2.4.2.2). The fire damper shall operate automatically, but shall also be capable of being closed manually* from both sides of the division. The damper shall be fitted with a visible indicator which shows the operating position of the damper. Fire dampers are not required, however, where ducts pass through spaces surrounded by “A” class divisions, without serving those spaces, provided those ducts have the same fire integrity as the divisions which they penetrate. A duct of cross-sectional area exceeding 0.075 m² shall not be divided into smaller ducts at the penetration of an “A” class division and then recombined into the original duct once through the division to avoid installing the damper required by this provision. (SOLAS Reg. II-2/9.7.3.1)

*** IMO interpretation**

Manual closing may be achieved by mechanical means of release or by remote operation of the fire damper by means of a fail-safe electrical switch or pneumatic release (spring-loaded, etc.) on both sides of the division. (MSC/Circ.1120)

**** IACS interpretation**

Ducts or pipes with free sectional area of 0.075 m² or less need to be fitted with fire damper at their passage through Class "A" divisions in those cases indicated in 7.3.2 and 7.3.3 (Regulations 9.7.2.2 and 9.7.2.3). The fire damper can be omitted if the duct is arranged in compliance with the requirements of 7.3.4.2.1 and 7.3.4.2.2 (9.7.2.4.2.1 and 9.7.2.4.2.2). (IACS UI SC64)

7.4.2 Ventilation ducts with a free cross-sectional area exceeding 0.02 m² passing through "B" class bulkheads shall be lined with steel sheet sleeves of 900 mm in length, divided preferably into 450 mm on each side of the bulkheads unless the duct is of steel for this length. (SOLAS Reg. II-2/9.7.3.2)

IACS and IMO interpretation

When a duct passing through a division is to be in accordance with 1.9.2 and 7.4.2 (SOLAS regulations II-2/9.3.2 and II-2/9.7.3.2), no clearance should be allowed between the duct and the division. (IACS UI SC300, MSC.1/Circ.1655)

7.4.3 All fire dampers shall be capable of manual operation. The dampers shall have a direct mechanical means of release or, alternatively, be closed by electrical, hydraulic, or pneumatic operation. All dampers shall be manually operable from both sides of the division. Automatic fire dampers, including those capable of remote operation, shall have a failsafe mechanism that will close the damper in a fire even upon loss of electrical power or hydraulic or pneumatic pressure loss. Remotely operated fire dampers shall be capable of being reopened manually at the damper. (SOLAS Reg. II-2/9.7.3.3)

7.5 Closing appliances and stopping devices of ventilation

7.5.1 The main inlets and outlets of all ventilation systems shall be capable of being closed from outside the spaces being ventilated. The means of closing shall be easily accessible as well as prominently and permanently marked and shall indicate whether the shut-off is open or closed. (SOLAS, Reg. II-2/5.2.1.1)

IACS interpretation

Ventilation inlets and outlets located at outside boundaries are to be fitted with closing appliances as required by 7.5.1 (Reg. II-2/5.2.1.1) and need not comply with 7.4.1 (Reg. II-2/9.7.3.1). (IACS UI SC100)

7.5.2 Power ventilation of accommodation spaces, service spaces, cargo spaces, control stations and machinery spaces shall be capable of being stopped from an easily accessible position outside the space being served. This position shall not be readily cut off in the event of a fire in the spaces served. (SOLAS, Reg. II-2/5.2.1.2)

IACS and IMO interpretation

The fan in a HVAC temperature control unit, or a circulation fan inside a cabinet/switchboard, is not considered to be a ventilation fan as addressed in 7.5.2 (Reg.II-2/5.2.1.2), 17.1.5.2.1 (Reg.II-2/5.2.1.3) and Reg.II-2/7.9.3 (concerns fire alarm signalling systems in passenger ships), if it is not capable of supplying outside air to the space when the power ventilation is shut down (e.g., small units intended for re-circulation of air within a cabin).

Therefore, such fans need not be capable of being stopped from an easily accessible position (or a safe position) outside the space being served when applying 7.5.2 (SOLAS Reg.II-2/5.2.1.2) or 17.1.5.2.1 (Reg.II-2/5.2.1.3), and need not be capable of being controlled from a continuously manned central control station for passenger ships carrying more than 36

passengers when applying SOLAS Reg.II-2/7.9.3 (concerns fire alarm signalling systems in passenger ships). (IACS UI SC148, MSC.1/Circ.1555)

7.5.3 All inlets and outlets of the ventilation systems for machinery spaces, cargo spaces or other spaces provided with total flooding fire-extinguishing system shall be fitted with air-tight closing arrangements capable of being operated from outside of these spaces.

7.6 Ventilation of machinery spaces

7.6.1 General provisions

7.6.1.1 Machinery spaces of category A shall be adequately ventilated so as to ensure that when machinery or boilers therein are operating at full power in all weather conditions including heavy weather, an adequate supply of air is maintained to the spaces for the safety and comfort of personnel and the operation of the machinery. Any other machinery space shall be adequately ventilated appropriate for the purpose of that machinery space. (SOLAS, Reg. II-1/35)

7.6.1.2 Means shall be provided whereby normal operation of propulsion machinery can be sustained or restored even though one of the essential auxiliaries becomes inoperative. Special consideration shall be given to the malfunctioning of:

(...)

.8 the mechanical air supply for boilers;

(...)

However, the Administration, having regard to overall safety considerations, may accept a partial reduction in propulsion capability from normal operation. (SOLAS, Reg. II-1/26.3)

7.6.1.3 The ventilation of machinery spaces shall be sufficient under normal conditions to prevent accumulation of oil vapour. (SOLAS, Reg. II-2/4.2.2.2)

7.6.1.4 Provision shall be made for the extraction of gases heavier than air from the lower parts of those spaces, from the places below the floor plates where the gases may accumulate, as well as from the locations where fuel system appliances, settling and service tanks are installed.

7.6.1.5 The number of skylights, doors, ventilators, openings in funnels to permit exhaust ventilation and other openings to machinery spaces shall be reduced to a minimum consistent with the needs of ventilation and the proper and safe working of the ship. (SOLAS, Reg. II-2/9.5.2.1)

Note:

In accordance with SOLAS Reg. II-2/9.5.1.1, 7.6.1.3 and 7.6.1.5 apply to machinery spaces of category A however where the Administration considers it desirable, also to other machinery spaces.

7.6.1.6 Skylights shall be of steel and shall not contain glass panels. (SOLAS, Reg. II-2/9.5.2.2)

7.6.1.7 Shaft tunnels shall be provided with effective mechanical or natural ventilation. Pipe tunnels in the double bottom shall be provided with mechanical exhaust ventilation.

7.6.1.8 Fuel oil purifiers room, for heated oil fuel, shall be provided with independent mechanical ventilation or a ventilation arrangement which can be separated from the machinery space ventilation.

7.6.1.9 Means of control in machinery spaces

7.6.1.9.1 Means of control shall be provided for opening and closure of skylights, closure of openings in funnels which normally allow exhaust ventilation and closure of ventilator dampers. (SOLAS, Reg. II-2/5.2.2.1)

7.6.1.9.2 Means of control shall be provided for stopping ventilating fans. Controls provided for the power ventilation serving machinery spaces shall be grouped so as to be operable from two positions, one of which shall be outside such spaces. The means provided for stopping the power ventilation of the machinery spaces shall be entirely separate from the means provided for stopping ventilation of other spaces. (SOLAS, Reg. II-2/5.2.2.2)

Note:

Shutdown arrangements for periodically unattended machinery spaces – see 18.3.4.

7.6.1.9.3 Means of control shall be provided for stopping forced and induced draught fans (...). (SOLAS, Reg. II-2/5.2.2.3)

Controls required by this regulation should also be provided from the compartment itself. (4)
(IACS UR F35)

7.6.1.9.4 The controls* required in 7.6.9.1 to 7.6.9.3 (paragraphs 2.2.1 to 2.2.3) (...) shall be located outside the space concerned so they will not be cut off in the event of fire in the space they serve. (SOLAS, Reg. II-2/5.2.2.4)

*** IMO interpretation**

In machinery spaces of category A, controls to close off ventilation ducts (...) should be installed with due regard to the hot gases produced by a fire in the space concerned. (MSC/Circ.1120)

7.6.1.9.5 In passenger ships, the controls required in 7.6.9.1 to 7.6.9.4 (paragraphs 2.2.1 to 2.2.4) and in 7.6.4.3 (regulations 8.3.3 (...)) shall be situated at one control position or grouped in as few positions as possible to the satisfaction of the Administration. Such positions shall have a safe access from the open deck. (SOLAS, Reg. II-2/5.2.2.5)

7.6.2 Ventilation rooms serving machinery spaces of category A containing internal combustion machinery

7.6.2.1 Where a ventilation room serves only such an adjacent machinery space and there is no fire division between the ventilation room and the machinery space, the means for closing the ventilation duct or ducts serving the machinery space shall be located outside of the ventilation room and machinery space. (SOLAS, Reg. II-2/9.7.6.1)

7.6.2.2 Where a ventilation room serves such a machinery space as well as other spaces and is separated from the machinery space by a "A-0" class division, including penetrations, the means for closing the ventilation duct or ducts for the machinery space can be located in the ventilation room. (SOLAS, Reg. II-2/9.7.6.2)

7.6.3 Ventilation of emergency generator rooms

IACS UR M75

7.6.3.1 Application (1.)

The following requirements apply to closable ventilation louvers and ventilator closing appliances serving emergency generator rooms, where fitted.

7.6.3.2 Requirements (2.)

7.6.3.2.1 Ventilation louvers and closing appliances may either be hand-operated or power-operated (hydraulic/pneumatic/electric) and are to be operable under a fire condition. (2.1)

7.6.3.2.2 Hand-operated ventilation louvers and closing appliances are to be kept open during normal operation of the vessel. Corresponding instruction plates are to be provided at the location where hand-operation is provided. (2.2)

7.6.3.2.3 Power-operated ventilation louvers and closing appliances shall be of a fail-to-open type. Closed power-operated ventilation louvers and closing appliances are acceptable during normal operation of the vessel.

Power-operated ventilation louvers and closing appliances shall open automatically whenever the emergency generator is starting/in operation. (2.3)

7.6.3.3 It shall be possible to close ventilation openings by a manual operation from a clearly marked safe position outside the space where the closing operation can be easily confirmed. The louver status (open/closed) shall be indicated at this position. Such closing shall not be possible from any other remote position. (2.4)

END OF IACS UR M75

7.6.4 Release of smoke from machinery spaces

7.6.4.1 The provisions of this paragraph shall apply to machinery spaces of category A and, where the Administration considers desirable, to other machinery spaces. (SOLAS, Reg. II-2/8.3.1)

7.6.4.2 Suitable arrangements shall be made to permit the release of smoke, in the event of fire, from the space to be protected, subject to the provisions of 7.6.1.5 (regulation 9.5.2.1). The normal ventilation systems may be acceptable for this purpose. (SOLAS, Reg. II-2/8.3.2)

7.6.4.3 Means of control shall be provided for permitting the release of smoke and such controls* shall be located outside the space concerned so that, in the event of fire, they will not be cut off from the space they serve. (SOLAS, Reg. II-2/8.3.3)

*** IMO interpretation**

In machinery spaces of category A, controls to close off ventilation ducts and pipes should be installed with due regard to the hot gases produced by a fire in the space concerned. (MSC/Circ.1120)

7.6.4.4 In passenger ships, the controls required by 7.6.4.3 (paragraph 3.3) shall be situated at one control position or grouped in as few positions as possible to the satisfaction of the Administration. Such positions shall have a safe access from the open deck. (SOLAS, Reg. II-2/8.3.4)

7.7 Ventilation of control stations outside machinery spaces

7.7.1 Practicable measures shall be taken for control stations outside machinery spaces in order to ensure that ventilation, visibility and freedom from smoke are maintained so that, in the event of fire, the machinery and equipment contained therein may be supervised and continue to function effectively. Alternative and separate means of air supply shall be provided and air inlets of the two sources of supply shall be so disposed that the risk of both inlets drawing in smoke simultaneously is minimized. At the discretion of the Administration, such requirements need not apply to control stations situated on, and opening on to, an open deck or where local closing arrangements would be equally effective*. The ventilation system serving safety centres may be derived from the ventilation system serving the navigation bridge, unless located in an adjacent main vertical zone. (SOLAS, Reg. II-2/8.2)

*** IACS and IMO interpretation**

Equally effective local closing arrangements means that in case of ventilators these should be fitted with fire dampers or smoke dampers which could be closed easily within the control station in order to maintain the absence of smoke in the event of fire. (IACS UI SC39, MSC/Circ.1120)

7.8 Ventilation of the emergency fire pump space

See Part V, 3.2.2.4.8.

7.9 Ventilation of the storage rooms of fire-extinguishing medium

See Part V, 3.6.1.5.

7.10 Ventilation of battery rooms and battery lockers

7.10.1 Ventilation system (both inlet and outlet) of battery rooms and battery lockers shall be independent and ensure removal of air from upper parts of the ventilated rooms and lockers.

Ventilation ducts (both inlet and outlet ducts) shall be gastight.

7.10.2 Fresh air shall be supplied to the lower parts of the rooms and lockers.

7.10.3 Outlets to the open of ventilation ducts shall be so arranged as to prevent admission of water, precipitation and solids. Flame arresters shall not be fitted on these ducts. The outlets of the exhaust ventilation ducts shall be situated in such positions where the gases discharged will not cause any fire risk.

7.10.4 The main inlets and outlets of all ventilation systems shall be capable of being closed from outside the spaces being ventilated. The means of closing shall be easily accessible as well as prominently and permanently marked and shall indicate whether the shut-off is open or closed. (SOLAS, Reg. II-2/5.2.1.1)

IACS/IMO interpretations

- 1. Ventilation inlets and outlets located at outside boundaries are to be fitted with closing appliances as required by 7.10.4 (Reg. II-2/5.2.1.1) and need not comply with 7.4.1 (Reg. II-2/9.7.3.1). (IACS UI SC100)*
- 2. Battery room ventilators are to be fitted with a means of closing whenever:*
 - i) The battery room does not open directly onto an exposed deck.*
 - ii) The ventilation opening for the battery room is required to be fitted with a closing device according to the Load Line Convention (i.e. the height of the opening does not extend to more than 4.5 m (14.8 feet) above the deck for position 1 or to more than 2.3 m (7.5 feet) above the deck in position 2; or*
 - iii) The battery room is fitted with a fixed gas fire extinguishing system.*

Where a battery room ventilator is fitted with a closing device, then a warning notice stating, for example "This closing device is to be kept open and only closed in the event of fire or other emergency – Explosive gas", is to be provided at the closing device to mitigate the possibility of inadvertent closing. (IACS UI SC240, MSC.1/Circ.1434)

7.10.5 Ventilation of compartments containing batteries used for essential and emergency service

The ventilation arrangements for installation of vented type batteries¹⁾ which have charging power higher than 2kW are to be such that the quantity of air expelled is at least equal to:

$$Q = 110In$$

where

n = number of cells in series

- I = maximum current delivered by the charging equipment during gas formation, but not less than 25 per cent of the maximum obtainable charging current in amperes
 Q = quantity of air expelled in litres/hr.

The ventilation rate for compartments containing valve-regulated batteries²⁾ may be reduced to 25 per cent of that given above.

Notes:

- 1) A vented battery is one in which the cells have a cover provided with an opening through which products of electrolysis and evaporation are allowed to escape freely from the cells to atmosphere.
- 2) A valve-regulated battery is one in which cells are closed but have an arrangement (valve) which allows the escape of gas if the internal pressure exceeds a predetermined value. (IACS UR E18)
- 3) Remaining requirements of UR E18 – see *Part VIII*, 13.8.

7.10.6 Ventilation of accumulator battery lockers containing vented batteries with charging power not exceeding 2 kW, may be effected through holes in the lower and upper parts of the locker.

7.10.7 Cross-sectional area F of a vent duct in the case of natural ventilation of accumulator battery rooms or lockers shall not be less than that determined in accordance with the following formula:

$$F = 2.9 \cdot 10^{-3} Q \text{ [cm}^2\text{]}$$

however, not less than 40 cm²,

where:

- Q – quantity of air expelled, [litres/hr], determined in accordance with 7.10.5.

7.10.8 Natural ventilation of the rooms may be applied where:

- .1 required rate of air flow, determined in accordance with formula 7.10.5, is less than 85,000 litres/hr;
- .2 rake of the ventilation duct from vertical is less than 45°;
- .3 number of bends of the duct does not exceed 2;
- .4 length of the ventilation duct does not exceed 5 m;
- .5 ventilation performance does not depend on the wind direction.

7.10.9 Where the rate of air flow determined in accordance with formula 7.10.5 is 85,000 litres/hr or more, the accumulator battery room shall be provided with mechanical exhaust ventilation.

7.10.10 Internal surfaces of the exhaust ducts, as well as the fans and their motors shall be protected against the action of electrolyte vapours.

7.10.11 Fans shall be of non-sparking construction and fulfil the requirements specified in *Part VII*, 5.3.2 and their electric motors – the requirements specified in *Part VIII*, 22.2.1. It is recommended that the electric motors be not situated in the stream of discharged gases.

Inlet and outlet openings shall be fitted with wire mesh guards having the mesh size not exceeding 13 mm x 13 mm.

7.11 Ventilation of cargo spaces

Notes:

1. Ventilation of cargo spaces intended for the carriage of dangerous goods – see *Part V*, 7.2.4.

2. Ventilation of vehicle ,special category and ro-ro spaces – see 17.3.2.

7.11.1 In the case of carriage of cargoes, which require air changes in refrigerated spaces, proper ventilation system ensuring fresh air supply (cooled or heated), shall be provided.

7.11.2 Inlet and outlet ventilation openings for refrigerated cargo spaces shall be provided with arrangements for their tight closure.

7.12 Exhaust ducts from galley ranges in cargo ships

See *Part V*, 6.4.1.

7.13 Ventilation systems of cargo vessels of less than convention size

See *Part V*, 9.6.

CHAPTER 8**8 FUEL SYSTEMS****8.1 Limitations in the use of oil as fuel****8.1.1** The following limitations shall apply to the use of oil as fuel:

- .1 except as otherwise permitted by this paragraph, no oil fuel with a flashpoint of less than 60°C shall be used;*

* Refer to *Recommended procedures to prevent the illegal or accidental use of low-flashpoint cargo oil as fuel* (resolution A.565(14)).

- .2 in emergency generators oil fuel with a flashpoint of not less than 43°C may be used;
- .3 the use of oil fuel having a flashpoint of less than 60°C but not less than 43°C may be permitted (e.g., for feeding the emergency fire pump's engines and the auxiliary machines which are not located in the machinery spaces of category A) subject to the following:
 - .3.1 fuel oil tanks except those arranged in double bottom compartments shall be located outside of machinery spaces of category A;
 - .3.2 provisions for the measurement of oil temperature are provided on the suction pipe of the oil fuel pump;
 - .3.3 stop valves and/or cocks are provided on the inlet side and outlet side of the oil fuel strainers; and
 - .3.4 pipe joints of welded construction or of circular cone type or spherical type union joint are applied as much as possible;
- .4 in cargo ships, to which part G of chapter II-1 is not applicable*, the use of oil fuel having a lower flashpoint than otherwise specified in 8.1.1.1 (paragraph 2.1.1), for example crude oil, may be permitted provided that such fuel is not stored in any machinery space and subject to the approval by the Administration of the complete installation; and

IMO interpretation

Machineries and piping systems for the usage of fuel oil having a flashpoint of 43°C or less should comply with the following:

- .1 *provisions for the measurement of oil temperature should be provided on the suction pipe of oil fuel pump;*
- .2 *stop valves and/or cocks should be provided to the inlet side and outlet side of the oil fuel strainers; and*
- .3 *pipe joints of welded construction or of circular cone type or spherical type union joint should be applied as much as possible.*

Reference is made to 17.6.10.2 (IACS requirement M24 "Requirements concerning use of crude oil or slop as fuel for tanker boilers"). (MSC/Circ.1120)

*** Note:**

Ships to which part G of Chapter II-1 is not applicable are:

- gas carriers as defined in SOLAS regulation VII/11.2 using their cargo as fuel and complying with the requirements of the *IGC Code* or using other low-flashpoint gaseous fuels provided that the fuel storage and distribution systems design and arrangements for such gaseous fuels comply with the requirements of PRS' *Rules for the Classification and Construction of Sea-going Gas Tankers* for gas as a cargo,
- other ships using low-flashpoint fuels owned or operated by a Contracting Government and used, for the time being, only in Government non-commercial service.

.5 in ships, to which part G of chapter II-1 is applicable*, the use of oil fuel having a lower flashpoint than otherwise specified in 8.1.1.1 (paragraph 2.1.1) is permitted. (SOLAS, Reg. II-2/4.2.1)

*** Note:**

Ships to which Part G of Chapter II-1 is applicable are ships using low-flashpoint fuels (Part G of Chapter II-1 – see 8.1.3).

8.1.2 Ships using low-flashpoint fuels, other than oil fuel – see 8.11.

8.2 Oil fuel tanks

8.2.1 In a ship of 400 gross tonnage and above (...) oil shall not be carried in a forepeak tank or a tank forward of the collision bulkhead. (MARPOL, Reg. I/16.3)

Note:

IACS UR F33 is technically identical with the present 8.2.1 (MARPOL Reg. I/16.3), hence the UR is not repeated.

All ships other than those subject to 8.2.1 (paragraphs (...) 3 of this regulation) shall comply with the provisions of those paragraphs as far as is reasonable and practicable. (MARPOL, Reg. I/16.4)

8.2.2 Fuel oil (...) shall not be carried in forepeak tanks. (SOLAS, Reg. II-2/4.2.2.3.1)

8.2.3 As far as practicable, oil fuel tanks shall be part of the ships structure and shall be located outside machinery spaces of category A. Where oil fuel tanks, other than double bottom tanks, are necessarily located adjacent to or within machinery spaces of category A, at least one of their vertical sides shall be contiguous to the machinery space boundaries, and shall preferably have a common boundary with the double bottom tanks, and the area of the tank boundary common with the machinery spaces shall be kept to a minimum.* Where such tanks are situated within the boundaries of machinery spaces of category A they shall not contain oil fuel having a flashpoint of less than 60°C. In general, the use of free-standing oil fuel tanks shall be avoided. When such tanks are employed their use shall be prohibited in category A machinery spaces on passenger ships. Where permitted, they shall be placed in an oil-tight spill tray of ample size having a suitable drain pipe leading to a suitably sized spill oil tank. (SOLAS, Reg. II-2/4.2.2.3.2)

* Refer to Unified interpretations of SOLAS chapter II-2 (MSC.1/Circ.1322).

IMO interpretation

The arrangements in the diagrams below are acceptable provided that the requirements of Part II, 6.1.3 (MARPOL I/12A) are met.

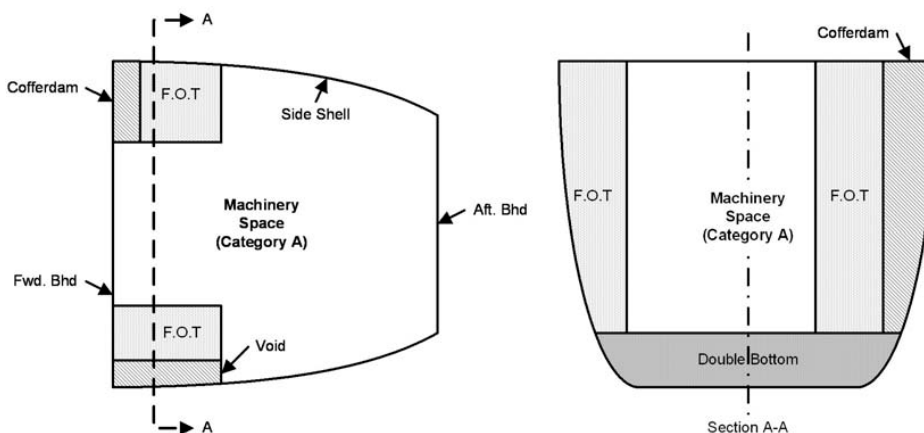

Oil fuel tank arrangements (MSC.1/Circ.1322)

8.2.4 Oil fuel tanks shall be located above the moulded line of the bottom shell plating nowhere less than the distance h and inboard of the moulded line of the side shell plating, nowhere less than the distance w (h and w – see 8.7.11). Alternatively ships shall comply with the accidental oil fuel outflow performance standard specified in MARPOL, Reg. I/12A, paragraph 11.

8.2.5 Oil fuel tanks, which do not form an integral part of the ship's structure, shall fulfil the provisions for the hull tanks, where applicable.

8.2.6 No oil fuel tank shall be situated where spillage or leakage therefrom can constitute a fire or explosion hazard by falling on heated surfaces. (SOLAS, Reg. II-2/4.2.2.3.3)

Air pipes of oil fuel tanks shall comply with 5.1.13.

8.2.7 The oil fuel tanks situated on open decks, superstructure decks and in other places open to the atmosphere shall be protected from exposure to the sun rays or a water spraying system shall be provided.

8.2.8 Oil fuel pipes, which, if damaged, would allow oil to escape from a storage, settling or daily service tank having a capacity of 500 l and above situated above the double bottom, shall be fitted with a cock or valve directly on the tank capable of being closed from a safe position outside the space concerned in the event of a fire occurring in the space in which such tanks are situated. In the special case of deep tanks situated in any shaft or pipe tunnel or similar space, valves on the tank shall be fitted, but control in the event of fire may be effected by means of an additional valve on the pipe or pipes outside the tunnel or similar space. If such an additional valve is fitted in the machinery space it shall be operated from a position outside this space. The controls for remote operation of the valve for the emergency generator fuel tank shall be in a separate location* from the controls for remote operation of other valves for tanks located in machinery spaces. (SOLAS Reg. II-2/4.2.2.3.4)

*** IMO interpretation**

The wording "separate location" does not mean separate spaces. (MSC/Circ.1120)

8.2.9 The oil fuel tanks shall be separated from drinking water and boiler feed water tanks, as well as from vegetable oil and lubricating oil tanks by means of cofferdams in accordance with the requirements specified in Part II, 9.2.4.1.

8.2.10 The distance from the walls of oil fuel tanks to outer surface of the boiler insulation shall be sufficient to ensure free flow of the air necessary to maintain the temperature of oil fuel in the tanks below the oil fuel flashpoint, except the cases specified in 8.4.4.

8.2.11 (...) Two fuel oil service tanks for each type of fuel used on board necessary for propulsion and vital systems or equivalent arrangements* shall be provided on each new ship, with a capacity of at least 8 h at maximum continuous rating of the propulsion plant and normal operating load at sea of the generator plant.*** (...) (SOLAS, Reg. II-1/26.11)

*** Refer to SOLAS II-2/4.2 requirements in 8.2, 8.3, 8.8 and 8.9 (regulation II-2/4.2, Arrangements for oil fuel, lubricating oil and other flammable oils).

Ships of gross tonnage less than 500 and ships of restricted service may be waived of these requirements subject to PRS acceptance.

Note:

See also 8.9.1/4.1.

*** IACS and IMO interpretation**

Arrangements complying with this regulation and acceptable "equivalent arrangements", for the most commonly utilised fuel systems, are shown below.

A service tank is a fuel oil tank which contains only fuel of a quality ready for use i.e. fuel of a grade and quality that meet the specification required by the equipment manufacturer. A service tank is to be declared as such and not to be used for any other purpose.

Use of a settling tank with or without purifiers, or purifiers alone, and one service tank is not acceptable as an "equivalent arrangement" to two service tanks.

1 Example 1

1.1 Requirement according to SOLAS - Main and Auxiliary Engines and Boiler(s) operating with Heavy Fuel Oil (HFO) (one fuel ship)

<p>HFO Serv. TK</p> <p>Capacity for at least 8 h Main Eng. + Aux. Boiler + Aux. Eng.</p>	<p>HFO Serv. TK</p> <p>Capacity for at least 8 h Main Eng. + Aux. Boiler + Aux. Eng.</p>	<p>MDO TK</p> <p>For initial cold starting or repair work of Engines/Boiler</p>
--	--	---

1.2 Equivalent arrangement¹⁾

<p>HFO Serv. TK</p> <p>Capacity for at least 8 h Main Eng. + Aux. Boiler + Aux. Eng.</p>	<p>MDO Serv. TK</p> <p>Capacity for at least 8 h Main Eng. + Aux. Boiler + Aux. Eng.</p>
--	--

This arrangement only applies where main and auxiliary engines can operate with heavy fuel oil under all load conditions and, in the case of main engines, during manoeuvring.

For pilot burners of Auxiliary Boilers if provided, an additional MDO tank for 8 hours may be necessary.

¹⁾ Any fuel oil which requires post service tank heating to achieve the required injection viscosity is not regarded in this context as MDO.

2 Example 2

2.1 Requirement according to SOLAS - Main Engine(s) and Auxiliary Boiler(s) operating with HFO and Auxiliary Engine operating with Marine Diesel Oil (MDO)

<p>HFO Serv. TK</p> <p>Capacity for at least 8 h Main Eng. + Aux. Boiler</p>	<p>HFO Serv. TK</p> <p>Capacity for at least 8 h Main Eng. + Aux. Boiler</p>	<p>MDO Serv. TK</p> <p>Capacity for at least 8 h Aux. Eng.</p>	<p>MDO Serv. TK</p> <p>Capacity for at least 8 h Aux. Eng.</p>
--	--	--	--

2.2 Equivalent arrangement *

<p>HFO Serv. TK</p> <p>Capacity for at least 8 h Main Eng. + Aux. Boiler</p>	<p>MDO Serv. TK</p> <p>Capacity for at least the highest of: 4h Main Eng. + Aux. Eng. + Aux. Boiler or 8h Aux. Eng. +Aux Boiler</p>	<p>MDO Serv. TK</p> <p>Capacity for at least the highest of: 4h Main Eng. + Aux. Eng. + Aux. Boiler or 8h Aux. Eng. +Aux Boiler</p>
--	---	---

3 The arrangements in 1.2 and 2.2 apply, provided the propulsion and vital systems which use two types of fuel support rapid fuel changeover and are capable of operating in all normal operating conditions at sea with both types of fuel (MDO and HFO). (IACS UI SC123, MSC.1/Circ.1464/Rev.1 Chapter 3, MSC.1/Circ.1572 Chapter 4)

8.2.12 Where oil fuel shall be stored in double bottom tanks, which are also used as water ballast tanks, provision shall be made for settling tanks. Where two daily service tanks are available, installation of settling tank is not required.

8.2.13 Oil fuel service tank for the emergency generating set's engine shall be located in the generating set compartment. Oil fuel from this tank shall not be used for other purposes. Capacity of the tank shall ensure operation of the set for a period of time specified in *Part VIII*: 9.3.1 to 9.3.3 – in case of cargo ships and 22.1.2.1 to 22.1.2.4 – in case of passenger ships.

8.2.14 Capacity of the oil fuel tank intended for the supply of emergency fire pump – see *Part V*, 3.2.2.4.5.2.

8.2.15 For the location of oil fuel tanks in cargo area on oil and chemical tankers – see *Part II*, 21.2.1.

8.3 Oil fuel bunkering and overflow arrangements

8.3.1 Bunkering of oil fuel shall be effected by means of a permanent pipeline provided with necessary valves and fittings enabling all storage tanks to be filled with oil fuel. The filling pipes shall be led to the tank bottom as close as practicable.

8.3.2 The filling pipes of the tanks situated above the double bottom shall be led through the tank wall in its upper part. Where such arrangement is impracticable, the filling pipes shall be fitted with a non-return valve installed directly on the tank.

8.3.3 Where the filling pipe is also used as a suction pipe, the non-return valve shall be replaced with a valve remotely closed from a readily accessible position outside the space in which the tank is located.

8.3.4 The filling pipe of emergency generator set service tank can be led through accommodation and service spaces and other oil fuel filling pipes can be led through sanitary spaces, provided that the pipe wall thickness is not less than 5 mm and the pipes have no detachable joints in way of these spaces.

8.3.5 Provision shall be made for a bunker sampler (a device designed to provide a sample of fuel oil during the bunkering period) in accordance with the requirements specified in IMO resolutions: MEPC.182(59) and MEPC.183(59) and the requirements specified in ISO 3170:2004.

8.3.6 Oil fuel tanks shall be fitted with overflow pipes.

(...) overflow pipes (...) shall discharge to a position where there is no risk of fire or explosion from the emergence of oils and vapour and shall not lead into crew spaces, passenger spaces nor into special category spaces, closed ro-ro cargo spaces, machinery spaces or similar spaces. (SOLAS Reg. II-2/4.2.2.4)

8.3.7 Air pipes being also overflow pipes shall not be connected to the air pipe of the overflow tank, but directly to that tank or to other overflow pipe of a sufficient diameter, connected to that tank.

Air pipes shall comply with 5.1.13.

8.3.8 (...) Any overflow pipe should have a sectional area of at least 1,25 times that of the filling pipe and should be led to an overflow tank of adequate capacity or to a storage tank having space reserved for overflow purposes. (...) (1) (IACS UR F35)

Oil fuel overflow tank capacity or the extra space of the storage tank shall be not less than 10-minute capacity of the fuel transfer pump.

The cross-sectional area of the overflow pipes of heavy fuel oil tanks shall not be less than 2 times the cross-sectional area of the filling pipes.

8.3.9 (...) An alarm device should be provided to give warning when the oil reaches a predetermined level in the tank (i.e. in the overflow or storage tank), or alternatively, a sight glass should be provided in the overflow pipe to indicate when any tank is overflowing. Such sight glasses should be placed on vertical pipes only and in readily visible positions. (1) (IACS UR F35)

8.3.10 Sight glasses shall be made of glass resistant to sudden temperature changes (e.g. borosilicate glass, thermal shock resistant min ΔT 200 K acc. to DIN 7080/7081).

8.3.11 Where overflow pipes from several tanks forming integral part of the hull structure and situated in different watertight compartments are led to a common line (manifold), the connections and the common line itself shall be situated above the deepest load waterline. In ships having a mark of subdivision in their symbol of class the connections and the common line itself shall be situated above the deepest damage load waterline.

8.3.12 Where, provided the requirements specified in 4.1.5 and 4.1.6 are fulfilled, a tank is alternately used for the carriage of oil fuel and water ballast or liquid and dry cargoes, the overflow pipes shall be so arranged as to preclude any possibility of liquid passing from one tank into another or vapours entering the tank loaded with dry cargo. In such cases, subject to PRS consent, the overflow pipes may be fitted with shut-off valves, provided these pipes are not used as air pipes.

8.3.13 Overflow pipes of oil fuel daily service and settling tanks shall be led to the tanks situated below the above-mentioned tanks.

8.3.14 Overflow arrangements of oil fuel daily service tanks in periodically unattended machinery spaces shall comply with additional requirements provided in 18.3.6.

8.4 Heating arrangements in oil fuel tanks

8.4.1 Where necessary oil fuel shall be heated by means of steam or water coils, or by means of electrical heating arrangements. In the case of electrical arrangements the requirements specified in *Part VIII*, 15.3 shall be fulfilled.

In the case of steam heating the relevant requirements specified in *Chapter 14* of this *Part VI* shall be also fulfilled.

8.4.2 Heating coils, as well as electric heating elements shall be located in the lowermost parts of the tanks.

8.4.3 The open ends of the suction pipes in daily service and settling tanks shall be situated above the heating coils or electric heating elements, to prevent, as far as possible, the coils and elements from being emerged.

8.4.4 Oil fuel in storage tanks should not to be heated to temperatures within 10°C below the flash point of the fuel oil, except that where oil fuel in service tanks, settling tanks and any other tanks in supply system is heated the following arrangements should be provided:

- the length of the vent pipes from such tanks and/or a cooling device is sufficient for cooling the vapours to below 60°C, or the outlet of the vent pipes is located 3m away from a source of ignition;
- the vent pipes are fitted with flame screens;
- there are no openings from the vapour space of the fuel tanks into machinery spaces (bolted manholes are acceptable);
- enclosed spaces are not located directly over such fuel tanks, except for vented cofferdams;
- electrical equipment is not fitted in the vapour space of the tanks, unless it is certified to be intrinsically safe. (6) (IACS UR F35)

8.4.5 Condensate from the heating coils shall be led to the observation tank fitted with a sight glass.

8.4.6 The pressure of steam used for heating oil fuel in tanks shall not exceed 0.7 MPa.

8.4.7 Heating arrangements of daily service and settling oil fuel tanks in periodically unattended machinery spaces shall comply with additional requirements provided in 18.3.6.

8.5 Water draining arrangements for oil fuel tanks

8.5.1 Settling and daily service tanks shall be provided with self-closing valves and drain pipes led to the drain tank. The drain pipes shall be fitted with sight glasses. Where a drip tray has been provided, an open funnel, instead of the sight glass, may be fitted.

8.6 Oil fuel leakage collecting arrangements

8.6.1 Containment provided for areas where frequent leakage may be expected such as oil burners, purifiers, drains and valves under daily service tanks etc. should be fitted with adequate drainage. Where drain pipes are provided from collected leakages, they should be led to a suitable oil drain tank not forming part of an overflow system. (2) (IACS REC. 58)

8.6.2 The internal diameter of the drain pipes shall not be less than 25 mm.

8.6.3 Drain pipes shall be led to the drain tank bottom as close as practicable. Where the drain tank is situated in the double bottom, structural measures shall be taken to prevent penetration of water into the engine room through the open ends of the drain pipes in event of damage to the shell plating. It is recommended that non-return valves reacting to a small pressure difference be used.

Provision shall be made for signals warning of the maximum permissible level being achieved in the drain tank.

8.6.4 Where pipes from the drip trays located in various watertight compartments are led to a common drain tank, constructional measures shall be provided to prevent the possibility of the overflow of water from the flooded compartment to other compartments through the open ends of drain pipes.

8.6.5 On every ship on open deck under or around each end of air, overflow or filling pipe, a container shall be provided of a capacity not less than:

- 0.16 m³ – for ships of 1,600 gross tonnage or more,
- 0.08 m³ – for ships of more than 300 gross tonnage but less than 1,600 gross tonnage,

- 0.02 m³ – for ships of 100 gross tonnage up to 300 gross tonnage; for such ships portable containers may be accepted.

Where the above arrangements are inconvenient or impracticable automatic closing valves shall be used. Such arrangement is subject to PRS acceptance in each particular case.

8.7 Oil fuel transfer pumps and piping arrangements

8.7.1 At least two power-driven pumps shall be provided for fuel transfer. One of these pumps may be a stand-by pump.

8.7.2 Any suitable pump, including oil fuel separator pump, may be used as stand-by pump.

8.7.3 For ships of restricted service, receiving in their symbol of class additional mark **II** or **III**, the stand-by pump is not required.

8.7.4 In ships with a daily consumption of fuel not exceeding 2 tonnes, one hand pump may be installed.

8.7.5 Oil fuel transfer pumps and oil fuel unit pumps, apart from remote control required by 8.7.8 and 8.7.9, shall be capable of being stopped locally.

8.7.6 Stop valves or cocks should be fitted on both suction and delivery sides of oil fuel pumps. All oil fuel pumps should be provided with pressure relief valves on the discharge side so that the discharged oil may be led to the suction side of the pump. (3) (IACS REC. 58)

8.7.7 Pressure relief valves need not be fitted when the system is served only by centrifugal pumps, so designed that the pressure delivered cannot exceed that for which the piping is designed. (3) (IACS REC. 58)

8.7.8 Means of control shall be provided for stopping (...) oil fuel transfer pumps, oil fuel unit pumps, (...) and oil separators (purifiers). (SOLAS, Reg. II-2/5.2.2.3)

Controls required by this regulation should also be provided from the compartment itself. (4) (IACS UR F35)

Note:

Shutdown arrangements for periodically unattended machinery spaces – see 18.3.4.

8.7.9 The controls* required in 8.7.8 (paragraphs (...) 2.2.3) and in 8.2.8 (regulation 4.2.2.3.4) shall be located outside the space concerned so they will not be cut off in the event of fire in the space they serve. (SOLAS, Reg. II-2/5.2.2.4)

*** IMO interpretation**

In machinery spaces of category A, controls to close off (...) pipes should be installed with due regard to the hot gases produced by a fire in the space concerned. (MSC/Circ.1120)

8.7.10 In passenger ships, the controls required in 8.7.8 and 8.7.9 (paragraphs 2.2.1 to 2.2.4) (...) shall be situated at one control position or grouped in as few positions as possible to the satisfaction of the Administration. Such positions shall have a safe access from the open deck. (SOLAS, Reg. II-2/5.2.2.5)

8.7.11 Lines of oil fuel piping located at a distance from the ship's bottom of less than h (...) or from the ship's side less than w (...) shall be fitted with valves or similar closing devices within or immediately adjacent to the oil fuel tank. These valves shall be capable of being brought into operation from a readily accessible enclosed space the location of which is accessible from the

navigation bridge or propulsion machinery control position without traversing exposed freeboard or superstructure decks. The valves shall close in case of remote control system failure (fail in a closed position) and shall be kept closed at sea at any time when the tank contains oil fuel except that they may be opened during oil fuel transfer operations. (MARPOL, Reg. I/12A.9)

Notes:

1. $h = B/20$ m or,
 $h = 2.0$ m, whichever is the lesser.
The minimum value of $h = 0.76$ m
2. B – see 1.2.7.
3. For ships having an aggregate oil fuel capacity of 600 m³ or more but less than 5 000 m³:
 $w = 0.4 + 2.4 C/20\,000$ m
The minimum value of $w = 1.0$ m, however for individual tanks with an oil fuel capacity of less than 500 m³ the minimum value is 0.76 m.
For ships having an aggregate oil fuel capacity of 5 000 m³ and over:
 $w = 0.5 + C/20\,000$ m or
 $w = 2.0$ m, whichever is the lesser.
The minimum value of $w = 1.0$ m
 C is the ship's total volume of oil fuel, including that of the small oil fuel tanks (capacity not greater than 30 m³), in m³, at 98% tank filling.

8.8 Oil fuel piping arrangements

8.8.1 In a ship in which oil fuel is used, the arrangements for the storage, distribution and utilization of the oil fuel shall be such as to ensure the safety of the ship and persons on board (...) (SOLAS Reg. II-2/4.2.2)

8.8.2 As far as practicable, parts of the oil fuel system containing heated oil under pressure exceeding 0.18 N/mm² shall not be placed in a concealed position such that defects and leakage cannot readily be observed. The machinery spaces in way of such parts of the oil fuel system shall be adequately illuminated. (SOLAS Reg. II-2/4.2.2.1)

Note:

By "heated oil" is meant oil at temperature higher than 60°C after heating or higher than the flashpoint of the oil, if this is lower than 60°C.

8.8.3 Provisions shall be made to prevent overpressure in any oil tank or in any part of the oil fuel system, including the filling pipes served by pumps on board. (...) relief valves shall discharge to a position where there is no risk of fire or explosion from the emergence of oils and vapour and shall not lead into crew spaces, passenger spaces nor into special category spaces, closed ro-ro cargo spaces, machinery spaces or similar spaces. (SOLAS Reg. II-2/4.2.2.4)

8.8.4 Oil fuel pipes and their valves and fittings shall be of steel or other approved material**, except that restricted use of flexible pipes shall be permissible in positions where the Administration is satisfied that they are necessary.* Such flexible pipes and end attachments shall be of approved fire-resisting materials of adequate strength and shall be constructed to the satisfaction of the Administration. For valves, fitted to oil fuel tanks and which are under static pressure, steel or spheroidal-graphite cast iron may be accepted. However, ordinary cast iron valves may be used in piping systems where the design pressure is lower than 7 bar and the design temperature is below 60°C. (SOLAS Reg. II-2/4.2.2.5.1)

Hose clamps and similar types of attachments for flexible pipes should not be permitted. (5) (IACS UR F35)

* Refer to recommendations published by the International Organization for Standardization, in particular publications ISO 15540:1999, *Fire resistance of hose assemblies – test methods* and ISO 15541:1999, *Fire resistance of hose assemblies – requirements for the test bench*.

**** IMO guidelines**

Housings and bodies of filters and strainers used in oil fuel, lubricating oil or other flammable oil systems should be made of steel or other equivalent material with a melting point above 930°C and with an elongation above 12%. Other housing and body materials may be utilized provided their use is specially considered on a case-by-case basis in relation to the risk of fire. (MSC.1/Circ.1321)

8.8.5 Oil fuel pipes shall not be made of copper or aluminium brass.

8.8.6 Precautions shall be taken to prevent any oil that may escape under pressure from any pump, filter or heater from coming into contact with heated surfaces. (SOLAS Reg. II-2/4.2.2.6.2)

8.8.7 Oil fuel lines shall not be located immediately above or near units of high temperature including boilers, steam pipelines, exhaust manifolds, silencers or other equipment required to be insulated by 1.11.1 (paragraph 2.2.6). As far as practicable, oil fuel lines shall be arranged far apart from hot surfaces, electrical installations or other sources of ignition and shall be screened or otherwise suitably protected to avoid oil spray or oil leakage onto the sources of ignition. The number of joints in such piping systems shall be kept to a minimum. (SOLAS Reg. II-2/4.2.2.5.3)

8.8.8 Cocks or valves should be provided for isolating instruments from the main pipes.

Temperature sensors should be fitted in pockets. (1) (IACS REC. 58)

8.8.9 All valves and cocks forming part of the fuel installation should be capable of being operated from readily accessible positions. (1) (IACS REC. 58)

Where such valves or cocks are located below the floor plates, their means of control shall be led above the floor plates.

8.8.10 Oil fuel piping shall be separated from any other systems.

Where satisfying the requirement specified in 8.2.1 and 8.2.2 is impracticable, and fuel tanks, including deep tanks, can be used as ballast tanks, effective arrangements for disconnecting ballast system from the tanks when they contain oil fuel, and disconnecting fuel system, when the tanks contain ballast water, shall be provided. Piping for the discharge of oily ballast water to port reception facilities shall be provided and it should terminate on open deck and be fitted with a standard discharge connection specified in 3.2.1.

8.8.11 Oil fuel pipes shall not be led through cargo holds, accommodation and service spaces or spaces intended for the carriage of dangerous or explosive materials.

8.8.12 Where the Administration may permit the conveying of oil and combustible liquids through accommodation and service spaces, the pipes conveying oil or combustible liquids shall be of a material approved by the Administration having regard to the fire risk. (SOLAS Reg. II-2/4.2.2.5.6)

8.8.13 Oil fuel pipes may be led through drinking water tanks and boiler feed water tanks only in tight tunnels forming an integral part of the tanks.

8.9 Oil fuel supply to oil fuelled machinery

8.9.1 Means shall be provided whereby normal operation of propulsion machinery can be sustained or restored even though one of the essential auxiliaries becomes inoperative. Special consideration shall be given to the malfunctioning of:

(...)

.4 the fuel oil supply systems for boilers or engines; **

(...)

** Refer to *Guidelines to minimize leakage from flammable liquid systems* (MSC/Circ.647) and *Guidelines on engine-room oil fuel systems* (MSC/Circ. 851)

However, the Administration, having regard to overall safety considerations, may accept a partial reduction in propulsion capability from normal operation. (SOLAS, Reg. II-1/26.3)

IACS and IMO interpretation

For ships intending to use Heavy Fuel Oil (HFO) or Marine Diesel Oil (MDO) in non-restricted areas and marine fuels with a sulphur content not exceeding 0,1 % m/m and minimum viscosity of 2 cSt in emission control areas, the following arrangements are considered to be in compliance with 8.9.1.4 (SOLAS II-1/26.3.4).

- 1) *In non-restricted areas, ships provided with two (2) fuel oil pumps that can each supply the fuel primarily used by the ship (i.e. HFO or MDO) in the required capacity for normal operation of the propulsion machinery.*
- 2) *In emission control areas one of the following configurations:*
 - a) *Fuel oil pumps as in 1), provided these are each suitable for marine fuels with a sulphur content not exceeding 0,1 % m/m and minimum viscosity of 2 cSt operation at the required capacity for normal operation of propulsion machinery,*
 - b) *When the fuel oil pumps in 1) are suitable to operate on marine fuels with a sulphur content not exceeding 0,1 % m/m and minimum viscosity of 2 cSt but one pump alone is not capable of delivering marine fuels with a sulphur content not exceeding 0,1 % m/m and minimum viscosity of 2 cSt at the required capacity, then both pumps may operate in parallel to achieve the required capacity for normal operation of propulsion machinery. In this case, one additional (third) fuel oil pump shall be provided. The additional pump shall, when operating in parallel with one of the pumps in 1), be suitable for and capable of delivering marine fuels with a sulphur content not exceeding 0,1 % m/m and minimum viscosity of 2 cSt at the required capacity for normal operation of the propulsion machinery.*
 - c) *In addition to 1), two separate fuel oil pumps shall be provided, each capable of and suitable for supplying marine fuels with a sulphur content not exceeding 0,1 % m/m and minimum viscosity of 2 cSt at the required capacity for normal operation of propulsion machinery.*

Note 1: *For the purpose of this interpretation if a marine distillate grade fuel with a different maximum sulphur content is specified by regulation for the area of operation of the ship (e.g., ECA, specific ports or local areas, etc.) then that maximum is to be applied.*

Note 2: *UR35.4.1 (automatic start of standby pumps) applies independent of the pump arrangement for vessels holding the class notation for unattended machinery space.*

Note:

UR35.4.1 means IACS UR M35 paragraph 35.4.1 which reads: *A suitable alarm is to be activated at the starting of those pumps for which the automatic starting is required.*

Note 3: *Where electrical power is required for the operation of propulsion machinery, the requirements are also applicable for machinery for power generation when such machinery is supplied by common fuel supply pumps. (IACS UI SC255, MSC.1/Circ.1467)*

8.9.2 In systems, where the engines are supplied with oil fuel by a booster pump, provision shall be made to ensure the oil fuel delivery to the engines in the event of the booster pump failure.

The above requirement does not apply to systems with two or more engines, where each engine is provided with its own booster pump and to ships of restricted service, receiving in their symbol of class additional mark **II** or **III**.

8.9.3 Where the main engines operate on two types of oil fuel (diesel oil and heavy fuel oil), measures shall be taken to prevent the mixing of the heavy fuel oil with the diesel oil for auxiliary engines intended for operation on diesel oil.

8.9.4 In multi-engine installations which are supplied from the same fuel source, means of isolating the fuel supply and spill piping to individual engines, shall be provided. The means of isolation shall not affect the operation of the other engines and shall be operable from a position not rendered inaccessible by a fire on any of the engines. (SOLAS, Reg. II-2/4.2.2.5.5)

Where practicable, isolating valves should be located at least 5 m away from engines in any direction. If this is not possible, the operating position of the valves should be protected by an obstruction. (...) (2.1.1) (MSC.1/Circ.1321, Chapter 4)

If the above is impracticable, other means of protection capable of enabling access to the isolating valves in the event of a fire might be acceptable. (2.1.2) (MSC.1/Circ.1321, Chapter 4)

Isolating valves controlled remotely could be acceptable. In this case, the operating mechanism should be protected from fire. (2.1.3) (MSC.1/Circ.1321, Chapter 4)

8.9.5 The system supplying oil fuel to main boilers and essential auxiliary boilers shall comprise at least two oil fuel units, each consisting of a pressure pump, a filter in the suction and delivery piping and a heater. The capacity of each of these units shall be sufficient to obtain the nominal parameters of the boilers.

The pressure pumps shall not be used for any other purpose and apart from remote control required by 8.7.8 and 8.7.9, shall be capable of being stopped locally.

8.9.6 The fuel supply to all burners should be capable of being automatically cut off in case of total lack of flame in the combustion chamber; moreover, this should be warned by a visual audible alarm. The alarms need not be fitted for domestic boilers. (7.2) (IACS REC. 58)

8.9.7 The piping supplying oil fuel to boiler shall be fitted, at each boiler, with quick closing valve controlled locally and remotely from a position outside the boiler room. This requirement applies to the boilers with hand-torch-ignited burners and boilers where oil fuel is fed by gravity.

8.9.8 In systems where oil fuel is fed to the boilers by gravity, filters shall be fitted in the supply piping.

8.9.9 Provision shall be made to ensure starting the main boilers without the aid of a power supply from outside the ship.

8.10 Recommendation for fuel oil treatment systems

IACS REC. 151

8.10.1 I Recommendation for the treatment of fuel oil on board ships

8.10.1.1 Application (1)

The following provisions should apply to fuel treatment systems for oil fuelled machinery on board ships. The aim of these recommendations is to improve the operational safety of the vessel by improving reliability of the oil fuelled machinery. The provisions cover the complete fuel oil treatment system, from the fuel bunker connection through to the interface with the oil fuelled machinery; this includes fuel tanks, the fuel cleaning equipment and the fuel conditioning equipment.

The implementation of 0.50% Sulphur limit for fuels used outside ECA-SOx from 1st January 2020 has resulted in fuel oils of an unprecedented diverse range of viscosity and quality characteristics and draws on the need for greater attention to ensuring that any fuel system design, from storage to combustion, especially the degree of flexibility needed to accommodate these fuel oils being offered to ships from one bunker to the next. This includes sufficient storage tanks to facilitate

segregation of new and old bunkers, sufficient cooling as well as heating capacity to switch from high to low and back to high viscosities.

This recommendation recognizes a disparity between the quality of fuel bunkered and delivered in accordance with ISO 8217:2017 and ISO/PAS 23263 and the fuel quality typically specified by marine diesel engine manufacturers. The performances of the system and equipment contained therein is fundamental to reducing the level of contaminants to within the oil fuelled machinery manufacturers specifications.

Footnote:

1. ISO 8217:2017(en) Petroleum products — Fuels (class F) — Specifications of marine fuels

2. ISO/PAS 23263:2019(en) Petroleum products — Fuels (class F) — Considerations for fuel suppliers and users regarding marine fuel quality in view of the implementation of maximum 0,50 % sulphur in 2020

8.10.1.2 Definitions (2)

8.10.1.2.1 A *service tank* is a fuel oil tank intended to contain only fuel that had been treated by the cleaning system. (2.1)

8.10.1.2.2 A *settling tank* is a purpose designed fuel oil tank intended for pre-cleaning of fuel oil from water and solids and heavier petroleum fractions by gravity. (2.2)

8.10.1.2.3 *Fuel oil* means petroleum residual and/or distillate fuels delivered to and intended for combustion purposes for propulsion or operation on board a ship.

8.10.1.2.4 *Fuel oil treatment tank* purpose designed fuel oil tank intended to perform process of cleaning and/or conditioning of the fuel oil. (2.4)

8.10.1.2.5 *Fuel oil treatment system* means a system intended for:

- Cleaning of the fuel oil by removal of water, catalyst fines (cat fines), water bound ash constituents (e.g. sodium) and particulate matter,
- Conditioning of the fuel oil to ensure efficient combustion. (2.5)

(Note: The “fuel oil treatment system” does not cover the use of additives.)

8.10.1.2.6 *Oil fuelled machinery* means all machinery combusting fuel oil, including main and auxiliary engines, boilers, gas turbines. (2.4)

8.10.1.3 System level objectives (3)

8.10.1.3.1 Functional objectives (3.1)

The fuel oil treatment system should provide fuel conditioning capability such that it ensures the ISO 8217 compliant fuel is ready for use by the oil-fuelled machinery and that it has no detrimental effect on the reliability and safety of such machinery.

8.10.1.3.2 Performance objectives (3.2)

8.10.1.3.2.1 The capacity and arrangements of the fuel oil treatment system should be suitable for ensuring availability of treated fuel oil for the Maximum Continuous Rating (MCR) of the propulsion plant and normal operating load at sea of the generator plant. (3.2.1)

8.10.1.3.2.2 The capacity and arrangements of the fuel oil treatment system should be determined on the basis of the requirements of the oil fuelled machinery manufacturer and the types of fuel: Residual Marine Fuel (RMF), Distillate Marine Fuel (DMF) to be bunkered to the ship. (3.2.2)

8.10.1.3.2.3 The fuel oil treatment system should be provided with redundancy so that failure of one system will not render the other system(s) inoperative. Arrangements should ensure that any single failure in the system will not interrupt the supply of clean fuel to machinery used for propulsion and electrical generating purposes. (3.2.3)

8.10.1.3.2.4 A sufficient number of main bunker tanks should be arranged to limit the need to mix newly bunkered fuel with fuel already on-board. When mixing of fuel oil is necessary, a compatibility test should be performed prior to transfer (see Annex D of ISO/PAS 23263:2019). (3.2.4)

8.10.1.3.2.5 The fuel oil should be of properties recommended by the oil fuelled machinery manufacturer. (3.2.5)

8.10.1.3.2.6 The maximum amount of water reaching the oil fuelled machinery should be 0.3% v/v or according to engine maker's recommendations. (3.2.6)

8.10.1.3.2.7 The maximum amount of catalyst fines reaching the engine should be 10 ppm Al+Si and in some instances this might rise to 15 ppm however every attempt should be made to reduce the catalyst to the lowest possible levels. (3.2.7)

Note: Particle size has a significant influence on the capacity of the centrifugal separators to lower the level of catalyst fines in the fuel, with particles of 2 microns or less being particularly difficult to remove. The presence of particles of 2 microns size or lower may cause difficulties in achieving the 10 ppm limit. Engine manufacturer recommendations should also be referred to for any further system specific recommendations.

8.10.1.3.3 System interfaces (3.3)

8.10.1.3.3.1 Bunkered fuels should meet ISO 8217:2017, ISO/PAS 23263:2019 or may meet an oil-fuelled machinery consumer manufacturers' specification. (3.3.1)

8.10.1.3.3.2 Sampling points (3.3.2)

8.10.1.3.3.2.1 The fuel oil treatment system should be provided with sampling points. (3.3.2.1)

8.10.1.3.3.2.2 The sampling points should meet MEPC.1/Circ.864/Rev.1 'Guidelines for on board sampling and verification of the sulphur content of the fuel oil used on board ships' (approved at MEPC74 in May 2019) and should be located as follows:

- .1 after the transfer pump discharge,
- .2 before and after the fuel cleaning equipment, and
- .3 after the fuel oil service tank, before any fuel change over valve,
- .4 before fuel enters the oil fuelled machinery. (3.3.2.2)

8.10.1.3.3.2.3 Sampling points should be provided at locations within the fuel oil system that enable samples of fuel oil to be taken in a safe manner for 'in-use' and means to obtain 'onboard samples'. (3.3.2.3)

8.10.1.3.3.2.4 The position of a sampling point should be such that the sample of the fuel oil is representative of the fuel oil quality passing that location within the system. (3.3.2.4)

8.10.1.3.3.2.5 The sampling points should be located in positions as far removed as possible from any heated surface or electrical equipment so as to preclude impingement of fuel oil onto such surfaces on equipment under all operating conditions. (3.3.2.5)

8.10.1.3.4 Verification (3.4)

8.10.1.3.4.1 Review of plans and documents (3.4.1)

8.10.1.3.4.1.1 Plans and documents demonstrating compliance with the recommendations included in section 8.10.1.3.4 (3.4) should be submitted for consideration. (3.4.1.1)

8.10.1.3.4.2 Shipboard verification (3.4.2)

8.10.1.3.4.2.1 The fuel oil treatment system is recommended to be inspected by the Surveyor after installation on board to confirm that the arrangement, installation and workmanship are in accordance with the equipment specification and this recommendation. (3.4.2.1)

8.10.1.3.4.2.2 The fuel oil treatment system should be provided with sampling cocks located in convenient positions. (3.4.2.2)

8.10.1.3.4.2.3 It is recommended that diagram of sampling points showing sampling points location be retained on board the ship and be presented to the surveyor during regular surveys. (3.4.2.3)

8.10.1.3.4.2.4 It is recommended that records of fuel sample analysis according to ISO 8217:2017 and ISO/PAS 23263:2019 be retained on board the ship and be presented to the surveyor during regular surveys. (3.4.2.4)

8.10.1.3.4.2.5 It is recommended that a drip sample of fuel should be taken during bunkering in accordance with ISO 13739:2020, in particular its Section 9 and taking into account ISO 3170:2004 for manual sampling or ISO 3171:1988 for automatic sampling as applicable. (3.4.2.5)

8.10.1.3.4.2.6 It is recommended that once a new bunker has started to be used, a fuel system audit is performed by a responsible person on board, taking fuel samples from before and after the treatment plant and from the fuel in-use designated sample point. (3.4.2.6)

8.10.1.4 Equipment level objectives (4)

8.10.1.4.1 Fuel tanks (4.1)

8.10.1.4.1.1 Functional objectives (4.1.1)

8.10.1.4.1.1.1 Settling and service tanks for fuel oil should be designed and constructed in such a way as to direct water and sludge towards a drainage outlet. (4.1.1.1)

8.10.1.4.1.1.2 If settling tanks are not provided, the fuel oil bunker (storage) and daily service tanks should be designed and constructed in such a way as to direct water and sludge towards a drainage outlet. (4.1.1.2)

8.10.1.4.1.2 Performance objectives (4.1.2)

8.10.1.4.1.2.1 Provisions should be made so that fuel is maintained at a temperature commensurate with the needs of system equipment to function in accordance with equipment manufacturers' requirements. (4.1.2.1)

8.10.1.4.1.2.2 A temperature controller of PID type should be fitted to ensure that the fuel is maintained at the temperature required for optimum system performance. (4.1.2.2)

8.10.1.4.1.3 Equipment interfaces(4.1.3)

8.10.1.4.1.3.1 Open drains for removing the water from fuel tanks should be fitted with valves or cocks of the self-closing type. (4.1.3.1)

8.10.1.4.1.3.2 A tank drain cock should not be considered as a sampling point. (4.1.3.2)

8.10.1.4.1.3.3 Fuel suction points should be located at an appropriate distance above the fuel-oil treatment tank drain point to prevent accumulated water and sludge being drawn into the fuel oil treatment system (e.g. a minimum 5% of the tank volume is below the suction of the high suction pipe). (4.1.3.3)

8.10.1.4.1.3.4 It is recommended that at least one low suction point and one high suction point be provided on the settling and service tank. (4.1.3.4)

8.10.1.4.1.4 Equipment Operations (4.1.4)

8.10.1.4.1.4.1 Provision should be made for collecting the discharge from the fuel oil tank bottom drain valves. Appropriate access should be provided for personnel to enable tank maintenance operations to be conducted safely. (4.1.4.1)

8.10.1.4.1.5 Physical characteristics (4.1.5)

8.10.1.4.1.5.1 The bottoms of fuel settling tanks and fuel service tanks should slope towards the drainage outlet. (4.1.5.1)

8.10.1.4.1.5.2 The internal surfaces of the bottoms of heavy fuel oil settling tanks and service tanks should be such that the passage of sludge to the lowest part of the tank is not restricted. (4.1.5.2)

8.10.1.4.1.5.3 The materials and/or their surface treatment used for the storage and distribution of fuel oil should be selected such that they should be able to withstand the fuel oil temperature and they do not introduce contamination or have an effect on changing the properties of the fuel. (4.1.5.3)

8.10.1.4.1.5.4 The service tank overflow return line to the settling tank should be drawn from near the bottom of the service tank to the top of the settling tank to ensure any accumulating sediment in the service tank bottom is minimised. (4.1.5.4)

8.10.1.4.1.6 Verification (4.1.6)

8.10.1.4.1.6.1 Review of plans and documents

- .1 Plans and documents demonstrating compliance with the recommendations of section 8.10.1.4.1 (4.1) should be submitted for consideration. (4.1.6.1)

8.10.1.4.1.6.2 Manufacturing

- .1 It is recommended to confirm that the sampling device is of an appropriate type recognized by the Society. (4.1.6.2)

8.10.1.4.2 Fuel temperature management equipment (4.2)

8.10.1.4.2.1 Functional objectives (4.2.1)

8.10.1.4.2.1.1 Heaters and coolers should safely manage the temperature of fuel oil, commensurate with the needs of the system design from storage to combustion machinery fuel rail. Cold Filter Plugging points and Cloud Points as well as the pour point for DMF fuels need to be considered in light of the ship's intended operating area and ambient temperatures. (4.2.1.1)

8.10.1.4.2.1.2 Where steam heaters or heaters using other heating media are provided in fuel (...) oil systems, they should be fitted with at least a high temperature alarm or low flow alarm in

addition to a temperature control, except where the temperature dangerous for the ignition of the medium cannot be reached. (4.1) (IACS REC. 58)

8.10.1.4.2.1.3 When electric heaters are fitted, means should be provided to ensure that heating elements are permanently submerged during the operation.

In order to avoid in any case a surface temperature of heating element above 220°C, a safety temperature switch, independent from the automatic control sensor, should be provided. The safety switch should cut off the electrical power supply in the event of excessive temperature and shall be provided with manual reset. (4.2) (IACS REC. 58)

8.10.1.4.2.1.4 There is an increased likelihood of oil fuelled machinery having to use low viscosity fuel oils such as less than 3.0 cSt at 40°C and it is therefore recommended to install a cooler to an appropriate location in the fuel oil booster circuit including return line to ensure greater flexibility that minimum fuel viscosity specified by the equipment manufacturers can be maintained. (4.2.1.2)

8.10.1.4.2.1.5 Fuel heater control should be able to respond quickly to sudden fuel flow changes to avoid overheating, for example, during the discharge cycles of the centrifugal separators. (4.2.1.3)

8.10.1.4.2.1.6 The presence on board of spare heaters and coolers should be considered. (4.2.1.4)

8.10.1.4.2.2 Performance objectives (4.2.2)

8.10.1.4.2.2.1 Where heating or cooling of the fuel oil is required for the efficient functioning of the fuel oil treatment system, a minimum of two heating or cooling units should be provided. Each heating or cooling unit should be of sufficient capacity to maintain the required temperature of the fuel oil for the required delivery flow rate. (4.2.2.1)

8.10.1.4.2.2.2 Automatic viscosity controllers should be provided as the primary means to control required injection viscosity with manual temperature control being only a secondary back up options in order to ensure that the broadening range of fuel formulations to meet the lower sulphur limits for both inside and outside ECA-SO_x operations is addressed smoothly and not overlooked by the crew. (4.2.2.2)

8.10.1.4.2.3 Equipment interfaces (4.2.3)

8.10.1.4.2.3.1 Heaters and coolers should be located to avoid oil spray or oil leakages onto hot surfaces or other sources of ignition, or onto rotating machinery parts. Where necessary, shielding should be provided. (4.2.3.1)

8.10.1.4.2.3.2 Heaters and coolers should be located to allow easy access for routine maintenance. (4.2.3.2)

8.10.1.4.2.4 Verification (4.2.4)

8.10.1.4.2.4.1 Review of plans and documents

- 1 Plans and documents demonstrating compliance with the recommendations of section 8.10.1.4.2 (4.2) should be submitted for consideration. (4.2.4.1)

8.10.1.4.2.4.2 Manufacturing

- 1 It is recommended that final testing of heaters and coolers be conducted in the presence of the Society's Surveyor or an Alternative Certification Scheme specified in *Publication*

115/P – *Alternative Certification Scheme for Classification of Ship Machinery Equipment and Materials* (UR Z26) be applied to manufacturing and testing. Alternatively, testing at an “accredited laboratory/testing facility” could be considered. (4.2.4.2)

8.10.1.4.2.4.3 Shipboard verification

- .1 It is recommended that satisfactory heater or cooler operation be verified after installation on board.
- .2 Verification of the viscosity/temperature control system operation should be carried out according to the engine oil fuelled machinery requirements. (4.2.4.3)

8.10.1.4.3 Pumps (4.3)

8.10.1.4.3.1 Functional objectives (4.3.1)

8.10.1.4.3.1.1 Fuel pumps should be capable of pumping all grades of fuel expected within the section of fuel system to which they are fitted. (4.3.1.1)

8.10.1.4.3.2 Performance objectives (4.3.2)

8.10.1.4.3.2.1 Fuel pump capacity should ensure that fuel flow rate through the fuel system is sufficient to maintain the installed oil-fuelled machinery’s fuel consumption during normal operation, according to 8.9.1 (SOLAS Regulation II-1/26.3). (4.3.2.1)

8.10.1.4.3.3 Equipment interfaces (4.3.3)

8.10.1.4.3.3.1 Fuel pumps should be protected from coarse and abrasive solids entering the pump. The degree to which such solids are filtered should be in accordance with the pump manufacturer’s instructions. (4.3.3.1)

8.10.1.4.3.3.2 Pumps should be located to allow easy access for routine inspection and maintenance. (4.3.3.2)

8.10.1.4.3.4 Verification (4.3.4)

8.10.1.4.3.4.1 Review of plans and documents

- .1 Plans and documents demonstrating compliance with the recommendations of section 8.10.1.4.3 (4.3) should be submitted for consideration. (4.3.4.1)

8.10.1.4.3.4.2 Manufacturing

- .1 It is recommended that final testing of fuel pumps be conducted in the presence of the Society’s Surveyor or an Alternative Certification Scheme specified in *Publication 115/P – Alternative Certification Scheme for Classification of Ship Machinery Equipment and Materials* (UR Z26) be applied to manufacturing and testing. (4.3.4.2)

8.10.1.4.3.4.3 Shipboard verification

- .1 It is recommended that satisfactory fuel pump operation be verified after installation on board. (4.3.4.3)

8.10.1.4.4 Filters (4.4)

8.10.1.4.4.1 Functional objectives (4.4.1)

8.10.1.4.4.1.1 Fuel filters should reduce the level of contaminants (i.e., metallic particles/sediments etc.) in the fuel in order to minimise wear or other damage to functional elements of the fuel system e.g. pumps and oil fuelled machinery. (4.4.1.1)

8.10.1.4.4.2 Performance objectives (4.4.2)

8.10.1.4.4.2.1 Capacity of fuel filters should be sufficient to reduce the level of contaminants in the fuel to a level commensurate with the downstream equipment manufacturers' specifications. (4.4.2.1)

8.10.1.4.4.3 Equipment interfaces (4.4.3)

8.10.1.4.4.3.1 Filters should be located to avoid oil spray or oil leakages onto hot surfaces or other sources of ignition, or onto rotating machinery parts. Where necessary, shielding should be provided. (4.4.3.1)

8.10.1.4.4.3.2 Filters should be located to allow easy access for routine maintenance. (4.4.3.2)

8.10.1.4.4.3.3 The arrangements of filters should be such that any unit can be cleaned without interrupting the supply of filtered oil to the combustion system. (4.4.3.3)

8.10.1.4.4.3.4 The design of filter and strainer arrangements should be such as to avoid the possibility of them being opened inadvertently when under pressure. (4.4.3.4)

8.10.1.4.4.3.5 Oil filters fitted in parallel for the purpose of enabling cleaning without disrupting oil supply to engines (e.g. duplex filters) should be provided with arrangements that will minimise the possibility of a filter under pressure being opened by mistake.

Filters/filter chambers should be provided with suitable means for:

- venting when put into operation;
- depressurising before being opened.

Valves or cocks with drain pipes led to a safe location should be used for this purpose. (5.6.1) (IACS REC. 58)

8.10.1.4.4.4 Equipment Operations (4.4.4)

8.10.1.4.4.4.1 The design and construction of fuel filters should facilitate their safe maintenance and replacement of filter elements. (4.4.4.1)

8.10.1.4.4.5 Physical characteristics (4.4.5)

8.10.1.4.4.5.1 Filters should be fitted in the fuel oil supply lines to each oil fuelled machinery to ensure that only suitably filtered oil is fed to the combustion system. (4.4.5.1)

8.10.1.4.4.6 Verification (4.4.6)

8.10.1.4.4.6.1 Manufacturing

- .1 The manufacturer should verify and document that each fuel filter meets the declared performance specifications. (4.4.6.1)

8.10.1.4.4.6.2 Shipboard verification

- .1 It is recommended that maintenance records for fuel oil filters be available to the surveyor during regular surveys. (4.4.6.2)

8.10.1.4.5 Centrifugal Separators (4.5)

8.10.1.4.5.1 Functional objectives (4.5.1)

8.10.1.4.5.1.1 Where necessary to ensure reliable operation of main propulsion machinery and all auxiliary machinery essential to the propulsion and the safety of the ship, centrifugal separators should remove water, **abrasive particles and sediments** that would otherwise cause excessive wear or other related failures of the oil fuelled machinery. **(4.5.1.1)**

8.10.1.4.5.2 Performance objectives (4.5.2)

8.10.1.4.5.2.1 The total installed capacity of centrifugal separators should be determined as part of the overall system design in order to achieve the oil fuelled machinery manufacturers requirements for fuel quality. However, a minimum of two separators, each of a capacity to ensure reliable operation of the fuel oil fuelled machinery, should be fitted, and arranged so that they can be operated in parallel to address the removal of gross contamination of water and abrasives. **(4.5.2.1)**

8.10.1.4.5.2.2 The performance of the separator should not be impaired by any equipment upstream or downstream of it in the system as recommended by the separator manufactures. **(4.5.2.2)**

8.10.1.4.5.3 Equipment interfaces (4.5.3)

8.10.1.4.5.3.1 Centrifugal separators should be located to avoid oil spray or oil leakages onto hot surfaces or other sources of ignition, or onto rotating machinery parts. Where necessary, shielding should be provided. **(4.5.3.1)**

8.10.1.4.5.3.2 Fuel oil purifiers for heated fuel oil should be subject to the following.

(a) The fuel oil purifiers should be placed in a separate room, enclosed by steel bulkheads extending from deck to deck and provided with self-closing steel doors.

(b) The room should be provided with:

- .1** independent mechanical ventilation or a ventilation arrangement which can be isolated from the machinery space ventilation, (see also 7.6.1.8)
- .2** fire detecting system,
- .3** fixed fire extinguishing installation:
 - The extinguishing installation should be capable of being activated from outside the room.
 - Closing of ventilation openings should be effected from a position close to where the extinguishing system is activated.
 - The extinguishing system should be separate for the room, but may be a part of the main fire extinguishing system for the machinery space. **(9.1)** (IACS REC. 58)

8.10.1.4.5.3.3 Where the size and/or design of the engine room makes it impracticable to locate the fuel oil purifiers in a separate space, special consideration should be given with regard to location, containment of possible leakages, and shielding and ventilation. (see 8.6)

A local fixed fire extinguishing system should be provided, capable of being activated automatically or activated manually from the machinery control position or from other suitable

location. If automatic release is provided, additional manual release should be arranged. (9.2)
(IACS REC. 58)

8.10.1.4.5.3.4 Centrifugal separators should be located to allow easy access for routine maintenance. (4.5.3.2)

8.10.1.4.5.4 **Equipment Operations** (4.5.4)

8.10.1.4.5.4.1 The design and construction of centrifugal separators should facilitate their maintenance in a safe manner. (4.5.4.1)

8.10.1.4.5.5 **Verification** (4.5.5)

8.10.1.4.5.5.1 **Recognised standards**

- .1 Centrifugal separators should be certified for a flow rating in accordance with a recognised standard e.g. EN 17763:2022, Centrifuges – Marine fuel centrifuges – Determination of particle separation performance and certified flow rate (CFR) under defined test conditions.
- .2 Centrifugal separators should meet the safety requirements of a recognised standard, e.g. EN 12547:2014, Centrifuges – Common safety requirements. (4.5.5.1)

8.10.1.4.5.5.2 **Manufacturing**

- .1 It is recommended that final testing of centrifugal separators be conducted in the presence of the Society’s Surveyor or an Alternative Certification Scheme specified in *Publication 115/P – Alternative Certification Scheme for Classification of Ship Machinery Equipment and Materials* (UR Z26) be applied to manufacturing and testing. Alternatively, testing at an “accredited laboratory/testing facility” could be considered. (4.5.5.2)

8.10.1.4.5.5.3 **Shipboard verification**

- .1 It is recommended that correct operation of centrifugal separators be verified after installation on-board.
- .2 It is recommended that maintenance records of centrifugal separators be available to Surveyors during regular surveys. (4.5.5.3)

8.10.2 **II Tests procedures to confirm the ability of RMF fuel oil pumps operation with marine fuels with low viscosity**

8.10.2.1 **Application** (5)

8.10.2.1.1 The following provision should be applied to the fuel oil pumps used in the fuel oil treatment and transfer systems when operating with marine fuels with low viscosity. (5.1)

8.10.2.1.2 The provision should be applied to:

- Primary essential services fuel oil pumps (main and stand-by) used in all services that need to be maintained in continuous operation. These include: separator fuel oil supply pumps; booster pumps, feeder pumps, fuel valve cooling pumps, (in systems which use fuel oil for this service).
- Fuel pumps that are not required to be in continuous operation, e.g. fuel oil transfer pumps. (5.2)

8.10.2.2 **Fuel oil pump arrangements** (6)

For ships intending to use RMF and/or DMF in non-restricted areas and marine fuels with a minimum viscosity of 2.0 cSt in emission control areas, the pump arrangements should be based upon MSC.1/Circ.1467 in compliance with 8.9.1 (SOLAS regulation II-I/26.3.4). (See also 8.9.1 IACS Interpretation (IACS UI SC255)).

8.10.2.3 Tests procedures to confirm the ability of RMF fuel oil pumps operation with marine fuels with a minimum viscosity of 2.0 cSt (7)

8.10.2.3.1 Testing (7.1)

8.10.2.3.1.1 Each fuel oil pump intended for use in a fuel oil system on board a ship should be subjected to testing in the presence of the Society's Surveyor, or an Alternative Certification Scheme specified in *Publication 115/P – Alternative Certification Scheme for Classification of Ship Machinery Equipment and Materials (UR Z26)* should be applied to manufacturing and testing. (7.1.1)

8.10.2.3.1.2 Type tests carried out for a particular type of pump will be accepted for all pumps of the same type built by both Licensors and Licensees. (7.1.2)

8.10.2.3.2 Running test (7.2)

8.10.2.3.2.1 A running test should be carried out with a minimum or lower viscosity fuel oil as specified in ISO 8217:2017 Specifications for Marine Fuels and ISO/PAS 23263:2019; recommended fuel oil viscosity value for the test should be 2.0 cSt at the fuel pump. (7.2.1)

8.10.2.3.2.2 The lubricity of fuel oil for running test should be less than 520 μm as determined by a high-frequency reciprocating rig test according to ISO 12156-1:2018. (7.2.2)

8.10.2.3.2.3 The running test should be conducted for a minimum of 250 hours for pumps for both continuous and non-continuous operation and at a discharge pressure equal to the nominal pump pressure rating. (7.2.3)

8.10.2.3.2.4 During the running test the following data should be verified:

- volume rate of flow Q [m^3/h]
- delivery head H [m]
- pump power input P [kW]
- speed of rotation n [min^{-1}] (7.2.4)

8.10.2.3.2.5 During the running test, the pump should be checked for smooth running (for example ISO 10816 series and/or ISO 20816-1:2016 could be used as a basis for acceptance) and bearing temperature. The assessment should be based on international standard or a Society's requirements, if applicable. This may be based on the pump manufacturer's in-house testing procedures acceptable to the Society. (7.2.5)

8.10.2.3.3 Pumps suitability (7.3)

8.10.2.3.3.1 All elastomeric components in the fuel oil system (e.g. diaphragms) should be made of fluoro-rubber or other material suitable for use with marine fuels according to MSC.1/Circ.1321. (7.3.1)

8.10.2.3.3.2 Displacement pumps should be fitted with relief valves. The discharge from the relief valve is normally to be led back to suction side of the pump. (7.3.2)

8.10.2.3.3.3 Fuel treatment system performance in the removal of catfines and water is recommended to be regularly assessed, by drawing and analyzing samples from before and after the purifier plant and after the service tank to ensure that the catfines and water levels do not exceed maximum engine entry levels recommended by engine manufacturers. (7.3.3)

8.10.2.3.3.4 Compatibility test kits, approved or recommended by the fuel oil manufacturer (e.g., testing acc. to ASTM D4740 – 20 method), should be used when bunkering two or more different fuel types, e.g. a high sulphur and low 0,10% m/m sulphur fuel. (7.3.4)

8.10.2.3.3.5 An automated fuel oil changeover valve/system or manual valve/system that can provide for timed changeover of fuel oil from one type to another should be provided and done in accordance with the engine manufacturers' recommendation. (7.3.5)

8.10.2.3.3.6 Each vessel or installation should have established procedures for fuel oil changeover and crew should be trained how to do it safely. (7.3.6)

8.10.2.3.4 Verification of pump design and test documentation (7.4)

8.10.2.3.4.1 All types of fuel oil pumps used for operation with low-sulphur fuel oil installed onboard should be tested and the evidence of test should be kept on-board. (7.4.1)

8.10.2.3.4.2 The scope of design documentation supplied by the pump manufacturer and kept on board should include:

- Pump(s) arrangement drawing, pump installation diagram with position and characteristics of sensors/monitoring system details,
- List of components with characteristics of materials critical for reliable operation of pump,
- Sealing arrangements,
- Reliability and life cycle data,
- Operational manual with performance and life cycle guidance,
- Test programme of the pump(s) for class survey. (7.4.2)

8.10.2.3.4.3 The following certificates are required to be submitted and attached to the pump documentation: (7.4.3)

8.10.2.3.4.3.1 The running test certificate containing:

- Manufacturer details,
- The test stand location and accreditation – approval details,
- Pump type and serial number,
- Duration of test,
- Viscosity of used medium,
- Parameters as mentioned in 7.2,
- Minimum operating temperature,
- Result of running test, (7.4.3.1)

8.10.2.3.4.3.2 Hydraulic test certificate. (7.4.3.2)

8.10.2.3.4.3.3 Materials certificates. (7.4.3.3)

8.11 The use of low flash-point fuels other than oil fuel

8.11.1 (...) Ships using low-flashpoint fuels, shall comply with the requirements of 8.11.2 and 8.11.3 (this part) in addition to any other applicable requirements of the present regulations. (SOLAS, Reg. II-1/56.1)

8.11.2 (...) ships, other than gas tankers, using low-flashpoint gas fuels (LNG, CNG, LPG, H₂) shall comply with the requirements of Publication 72/P–Safety requirements for ships using low flashpoint gases as fuel (the IGF Code). (SOLAS, Reg. II-1/57). See also 18.1.

8.11.3 Ships using alcohol as fuel shall comply with the requirements of Publication 38/I – Guidelines for the safety of ships using methyl/ethyl alcohol as fuel.

8.11.4 Ships using fuel cells for power generation shall comply with the requirements of Publication 37/I – Guidelines for the safety of ships using fuel cell power installations.

8.12 Oil fuel arrangements of cargo vessels of less than convention size

Oil fuel arrangements shall comply with requirements specified in Part V, 9.7.

8.13 Arrangements for gaseous fuel for domestic purpose

8.13.1 Gaseous fuel systems used for domestic purposes shall be approved by the Administration. Storage of gas bottles shall be located on the open deck or in a well ventilated space which opens only to the open deck*. (SOLAS, Reg. II-2/4.3)

* IACS and IMO interpretation

A portion of open deck, recessed into a deck structure, machinery casing, deck house, etc., utilized for the exclusive storage of gas bottles is considered acceptable for the purpose of 8.13.1 (regulation II-2/4.3) provided that:

- .1 such a recess has an unobstructed opening, except for small appurtenant structures, such as opening corner radii, small sills, pillars, etc. The opening may be provided with grating walls and door; and*
- .2 the depth of such a recess is not greater than 1 m.*

A portion of open deck meeting the above should be considered as open deck in applying tables 9.1 to 9.8 of SOLAS chapter II-2. (IACS UI SC214, MSC/Circ.1120)

8.13.2 Gaseous fuel system components shall fulfil the relevant national standards of the Administration. After installation on board, the system is subject to acceptance and tests in accordance with the approved test program.

CHAPTER 9**9 LUBRICATING OIL SYSTEMS****9.1 General requirements**

9.1.1 The arrangements for the storage, distribution and utilization of oil used in pressure lubrication systems shall be such as to ensure the safety of the ship and persons on board. The arrangements made in machinery spaces of category A, and whenever practicable in other machinery spaces, shall at least comply with the provisions of paragraphs 8.8.2 (2.2.1), 8.2.6 (2.2.3.3), 8.2.8 (2.2.3.4), 5.5.1, 5.5.2 and 5.5.3 (2.2.3.5), 5.1.13, 8.3.6 and 8.8.3 (2.2.4), 8.8.4 (2.2.5.1), 8.8.7 (2.2.5.3) and 1.11.1 and 8.8.6 (2.2.6), except that:

- .1** this does not preclude the use of sight-flow glasses in lubricating systems provided that they are shown by testing to have a suitable degree of fire resistance; and
- .2** sounding pipes may be authorized in machinery spaces; however, the requirements of 5.5.2.1 and 5.5.2.3 (paragraphs 2.2.3.5.1.1 and 2.2.3.5.1.3) need not be applied on condition that the sounding pipes are fitted with appropriate means of closure. (SOLAS, Reg. II-2/4.2.3.1)

9.1.2 The provisions of 8.2.8 (paragraph 2.2.3.4) shall also apply to lubricating oil tanks except those having a capacity less than 500 l, storage tanks on which valves are closed during the normal operation mode of the ship, or where it is determined that an unintended operation of a quick closing valve on the oil lubricating tank would endanger the safe operation of the main propulsion and essential auxiliary machinery. (SOLAS, Reg. II-2/4.2.3.2)

9.1.3 Means of control shall be provided for stopping (...) lubricating oil service pumps, (...) and oil separators (purifiers). However, 9.1.4 and 9.1.5 (paragraphs 2.2.4 and 2.2.5) need not apply to oily water separators. (SOLAS, Reg. II-2/5.2.2.3)

Controls required by this regulation should also be provided from the compartment itself. (4) (IACS UR F35)

Note:

Shutdown arrangements for periodically unattended machinery spaces – see 18.3.4.

9.1.4 The controls* required in 9.1.3 (paragraphs (...) 2.2.3 (...)) shall be located outside the space concerned so they will not be cut off in the event of fire in the space they serve. (SOLAS, Reg. II-2/5.2.2.4)

*** IMO interpretation**

In machinery spaces of category A, controls to close off (...) pipes should be installed with due regard to the hot gases produced by a fire in the space concerned. (MSC/Circ.1120)

9.1.5 In passenger ships, the controls required in 9.1.3 and 9.1.4 (paragraphs 2.2.1 to 2.2.4) (...) shall be situated at one control position or grouped in as few positions as possible to the satisfaction of the Administration. Such positions shall have a safe access from the open deck. (SOLAS, Reg. II-2/5.2.2.5)

Note:

Paragraphs 2.2.1 and 2.2.2 concern ventilation – see 7.6.9.1 and 7.6.9.2.

9.1.6 Cocks or valves should be provided for isolating instruments from the main pipes.

Temperature sensors should be fitted in pockets. (1) (IACS REC. 58)

9.1.7 Means shall be provided whereby normal operation of propulsion machinery can be sustained or restored even though one of the essential auxiliaries becomes inoperative. Special consideration shall be given to the malfunctioning of:

(...)

.5 the sources of lubricating oil pressure;

(...)

However, the Administration, having regard to overall safety considerations, may accept a partial reduction in propulsion capability from normal operation. (SOLAS, Reg. II-1/26.3)

9.1.8 Arrangements for lubricating oil in periodically unattended machinery spaces shall meet additional requirements provided in 18.3.6.

9.2 Pumps serving internal combustion engines, their gears and couplings

9.2.1 In machinery installations where one main engine is fitted, at least two lubricating oil pumps of equal capacity shall be provided. One of the pumps may be driven by the main engine.

For ships of restricted service, receiving in their symbol of class additional mark **II** or **III**, the stand-by pump is not required.

Lubricating oil circulating pumps, apart from remote control required by 9.1.3 and 9.1.4, shall be capable of being stopped locally.

9.2.2 In machinery installations where two or more main engines are fitted, each of them shall be provided with a separate lubricating pump, which may be driven by the engine.

The necessity of providing a stand-by pump or a spare one depends on the arrangement of connections in the lubricating oil system among the engines, and is subject to special consideration by PRS.

9.2.3 Oil circulating pumps in lubricating oil systems of main gears as well as pumps supplying hydraulic couplings shall fulfil the requirements specified in 9.2.1 and 9.2.2.

9.2.4 Where lubricating oil system for the main engines turbochargers is served by an independent electrically driven pump, provision shall be made for a stand-by pump and a gravity tank of sufficient capacity to ensure free rundown of the turbochargers in the event of a sudden stop of the oil pumps.

The tank shall be provided with a signalling system to give warning of reaching the lowest permissible oil level in the tank.

The oil pumps shall change-over automatically.

Provision shall be made for suitable means for checking the oil flow through the turbocharger bearings.

9.2.5 Each auxiliary engine and emergency generating set engine shall be provided with its own, independent lubricating system.

A common lubricating system for auxiliary engines and number of pumps in such system, including the stand-by ones are subject to separate consideration by PRS.

9.3 Lubricating oil supply to internal combustion engines and gears

9.3.1 Drain pipes from the engine crankcase to the circulating tank – their lower ends – shall be so arranged that they are permanently submerged in oil during the engine operation. The drain pipes of two or more engines shall not be interconnected.

9.3.2 The pipes of lubricating oil system shall not be connected to the pipes of other systems, except connections to the purifiers, which may be used for oil fuel purification, provided that reliable structural arrangements preventing oil fuel from being mixed with lubricating oil have been employed.

9.3.3 Where lubricating oil purifiers are employed, means preventing the main engine oil from being mixed with the auxiliary engines' lubricating oil shall be provided.

9.3.4 The pipes of the lubricating oil circulation systems shall be fitted with:

- magnetic strainer – on the suction pipe of lubricating pumps serving gears;
- one coarse filter (gauze) – on the pumps' suction pipe;
- two parallel filters, one interchangeable duplex filter or one self-cleaning filter – on the discharge pipe of the lubricating pump serving main engine.

The throughput of each lubricating oil filter shall exceed by 10% the capacity of the largest pump.

9.3.5 Oil filters fitted in parallel for the purpose of enabling cleaning without disrupting oil supply to engines (e.g. duplex filters) should be provided with arrangements that will minimise the possibility of a filter under pressure being opened by mistake.

Filters/filter chambers should be provided with suitable means for:

- venting when put into operation;
- depressurising before being opened.

Valves or cocks with drain pipes led to a safe location should be used for this purpose. **(6.1)** (IACS REC. 58)

9.3.6 Where steam heaters or heaters using other heating media are provided in (...) lubricating oil systems, they should be fitted with at least a high temperature alarm or low flow alarm in addition to a temperature control, except where the temperature dangerous for the ignition of the medium cannot be reached. **(4.1)** (IACS REC. 58)

9.3.7 When electric heaters are fitted, means should be provided to ensure that heating elements are permanently submerged during the operation.

In order to avoid in any case a surface temperature of heating element above 220°C, a safety temperature switch, independent from the automatic control sensor, should be provided. The safety switch should cut off the electrical power supply in the event of excessive temperature and shall be provided with manual reset. **(4.2)** (IACS REC. 58)

9.4 Pumps serving steam turbines and their gears

9.4.1 The lubricating oil system of the main turbine set shall be served by two oil pumps, the capacity of each pump being sufficient to ensure lubrication of the turbine set at the maximum output. At least one of the pumps shall be independently driven.

Where two main turbine sets are installed in one engine room, one independently driven stand-by pump for both turbine sets may be provided.

9.4.2 The design and location of lubricating oil pumps shall ensure reliable operation of the pumps without priming thereof before starting.

9.4.3 The lubricating system of the main turbine sets shall be of the gravity type. Every measure shall be taken to ensure supply of lubricating oil to the main turbine set in the event of failure of the main oil pump or until the turbine comes to rest in the event of interruption of power supply to the pumps' motors.

The use of circulation lubricating system without the gravity tank is subject to separate consideration by PRS.

9.5 Lubricating oil supply to steam turbines and their gears

9.5.1 The circulating oil piping, including all branches to individual receivers shall be made of copper, copper-nickel alloy or equivalent pipes.

9.5.2 The oil from lubricating oil system of the main turbine set may be taken only for the purposes of control, adjustment and safety devices and for lubrication of the main thrust bearing.

9.5.3 Main turbines are to be provided with a satisfactory emergency supply of lubricating oil which will come into use automatically when the pressure drops below a predetermined value.

The emergency supply may be obtained from a gravity tank containing sufficient oil to maintain adequate lubrication until the turbine is brought to rest or by equivalent means. If emergency pumps are used these are to be so arranged that their operation is not affected by failure of the power supply. Suitable arrangement for cooling the bearings after stopping may also be required. **(M26.2.3)** (IACS UR M26)

9.5.4 Each lubricating oil system shall be fitted with audible and visual alarm system to give warning, at the main turbine control station, of the reduction in pressure of the oil. In the gravity lubricating system, the alarm system shall be actuated at such a level of oil in the gravity tank, as to enable the start of the stand-by or emergency pump before the turbine is stopped by the safety system.

9.5.5 The capacity of tank in the gravity lubricating system shall not be less than 5 minutes demand at the rated output of the turbine set.

The tank shall be fitted with an overflow pipe with a sight glass well-lit and visible from the control station. The pipe cross-sectional area shall be at least 1.25 times the cross-sectional area of the discharge pipe from the pump.

Provision shall be made for the supply of oil by the pump to the oil receivers directly, with the omission of the tank.

9.5.6 The lubricating oil system of the main turbine set shall be fitted with two oil coolers, one of which shall be a stand-by cooler.

Where two turbine sets are installed in one engine room, only one stand-by oil cooler may be provided for both turbine sets.

9.5.7 The oil coolers of main turbine sets shall be served by circulating pumps of the main condensers.

9.5.8 Where a separate, independent pump has been provided for the oil coolers, provision shall be made additionally for a stand-by pump having a capacity of not less 0.6 times the capacity necessary for oil coolers at the rated output of the turbine set. Any general service pump may be used as a stand-by pump.

9.5.9 The lubricating oil system of the main turbine set and its gear shall also fulfil the requirements specified in 9.3.3.

9.6 Lubricating oil tanks

9.6.1 In a ship of 400 gross tonnage and above (...) oil shall not be carried in a forepeak tank or a tank forward of the collision bulkhead. (MARPOL, Reg. I/16.3)

Note:

IACS UR F33 is technically identical with the present Reg. I/16.3, hence the UR is not repeated.

All ships other than those subject to 9.6.1 (paragraphs (...) 3 of this regulation) shall comply with the provisions of those paragraphs as far as is reasonable and practicable. (MARPOL, Reg. I/16.4)

9.6.2 (...) lubrication oil (...) shall not be carried in forepeak tanks. (SOLAS, Reg. II-2/4.2.2.3.1)

9.6.3 The lubricating oil tanks shall be separated from oil fuel, boiler feed water and drinking water tanks by cofferdams in accordance with the requirements specified in *Part II*, 9.2.4.1.

9.6.4 The circulation drain tanks of turbines shall in each case be separated from the bottom shell plating by a cofferdam in accordance with the requirements specified in *Part II*, 9.2.4.1.

It is recommended that cofferdams be arranged under the engines. In the case of internal combustion engines, where such cofferdams are not provided, non-return or shut-off valves capable of being operated from above the engine room floor plates shall be fitted on the drain pipes from the engines crankcases.

9.6.5 In ships of unrestricted service and in ships of restricted service receiving in their symbol of class additional mark **I**, provision shall be made for a lubricating oil storage tank with a capacity sufficient for filling the system with oil to the working level.

It is recommended that the tank be arranged outside the double bottom.

9.6.6 The requirements given in 8.2.8 are also applicable to lubricating oil tanks except that the remote control is not required for:

- .1 valves on the storage tanks, which are normally closed, and
- .2 quick-closing valves, which if closed inadvertently would endanger the safe operation of the main propulsion or essential auxiliary machinery.

9.6.7 Where lubricating oil tanks are fitted with heating system, the requirements specified in 8.4 shall be fulfilled.

9.6.8 Lubricating oil tanks situated in machinery spaces of category A and, if practicable, also in other machinery spaces, shall fulfil the requirements specified in 8.6 concerning oil leakage collecting arrangements.

9.7 Arrangement of pipes

9.7.1 Oil pipes may be led through drinking water tanks and boiler feed water tanks only in tight tunnels forming an integral part of the tanks.

9.7.2 Oil pipes may be led through oil fuel tanks without the use of tight tunnels forming an integral part of the tanks provided that the pipes are seamless and connected by means of permanent joints. Where the use of permanent joints is impracticable, flange connections shall be used.

CHAPTER 10

10 OTHER OIL SYSTEMS

10.1 General requirements

10.1.1 In a ship of 400 gross tonnage and above (...) oil shall not be carried in a forepeak tank or a tank forward of the collision bulkhead. (MARPOL, Reg. I/16.3)

Note:

IACS UR F33 is technically identical with the present Reg. I/16.3, hence the UR is not repeated.

All ships other than those subject to 10.1.1 (paragraphs (...) 3 of this regulation) shall comply with the provisions of those paragraphs as far as is reasonable and practicable. (MARPOL, Reg. I/16.4)

10.1.2 (...) flammable oils shall not be carried in forepeak tanks. (SOLAS, Reg. II-2/4.2.2.3.1)

10.1.3 The arrangements for the storage, distribution and utilization of other flammable oils employed under pressure in power transmission systems, control and activating systems and heating systems shall be such as to ensure the safety of the ship and persons on board. Suitable oil collecting arrangements for leaks shall be fitted below hydraulic valves and cylinders. In locations where means of ignition are present, such arrangements shall at least comply with the provisions of paragraphs 8.2.6 (2.2.3.3), 5.5.1, 5.5.2 and 5.5.5 (2.2.3.5), 8.8.7 (2.2.5.3) and 1.11.1 and 8.8.6 (2.2.6) and with the provisions of paragraphs 8.8.3 (2.2.4) and 8.8.4 (2.2.5.1) in respect of strength and construction. (SOLAS, Reg. II-2/4.2.4)

IMO interpretation

The second sentence of 10.1.3 (regulation II-2/4.2.4) is not applicable to hydraulic valves and cylinders located on weather decks, in tanks, cofferdams or void spaces. (MSC/Circ.1120)

10.1.4 Systems containing heated oil under pressure under pressure exceeding 0.18 N/mm² shall comply with the requirements of 8.8.2.

10.1.5 Cocks or valves should be provided for isolating instruments from the main pipes.

Temperature sensors should be fitted in pockets. (1) (IACS REC. 58)

10.2 Thermal oil systems

10.2.1 Thermal oil systems shall be fitted with two circulating pumps – main and stand-by pump.

10.2.2 Thermal oil transfer pumps, apart from remote control required by 10.2.3 and 10.2.4, shall be capable of being stopped locally.

10.2.3 Means of control shall be provided for stopping (...) thermal oil circulating pumps (...). (SOLAS, Reg. II-2/5.2.2.3)

Controls required by this regulation should also be provided from the compartment itself. (4) (IACS UR F35)

10.2.4 The controls* required in 10.2.3 (paragraphs (...) 2.2.3 (...)) shall be located outside the space concerned so they will not be cut off in the event of fire in the space they serve. (SOLAS, Reg. II-2/5.2.2.4)

*** IMO interpretation**



In machinery spaces of category A, controls to close off (...) pipes should be installed with due regard to the hot gases produced by a fire in the space concerned. (MSC/Circ.1120)

Controls required by this regulation should also be provided from the compartment itself. (4) (IACS UR F35)

The thermal oil circulating pumps should be arranged for emergency stopping from a position outside the space where they are situated. (8.1) (IACS REC. 58)

Note:

Shutdown arrangements for periodically unattended machinery spaces – see 18.3.4.

10.2.5 In passenger ships, the controls required in 10.2.3 and 10.2.4 (paragraphs 2.2.1 to 2.2.4) (...) shall be situated at one control position or grouped in as few positions as possible to the satisfaction of the Administration. Such positions shall have a safe access from the open deck. (SOLAS, Reg. II-2/5.2.2.5)

Note:

Paragraphs 2.2.1 and 2.2.2 concern ventilation – see 7.6.9.1 and 7.6.9.2.

10.2.6 A transfer pump shall be provided for filling the compensation tanks and for the transfer of oil.

10.2.7 Thermal oil systems shall be provided with a compensation tank situated at the highest point of the system. Capacity of the tank shall be at least 1.5 times the increase of oil volume when the oil is heated up to its service temperature.

10.2.8 Compensation tank shall be provided with a level indicator complying with the requirements specified in 5.5.5. The lowermost allowable oil level shall be marked on the indicator.

10.2.9 Compensation tank shall be provided with an overflow pipe led to the thermal oil storage or draining tank.

10.2.10 Compensation tank shall be fitted with alarms for maximum and minimum allowable oil level.

10.2.11 Oil heating shall be automatically cut off in the case when oil level in the compensation tank drops below the allowable level.

10.2.12 The compensation tank of thermal oil system intended for the operation in the atmosphere of inert gas shall be fitted with pressure gauge and safety valve.

10.2.13 Effective means shall be provided for removal of vapours and gases from the system through the compensation tank.

10.2.14 Vents from expansion (i.e. compensation) tanks and thermal oil storage tanks of thermal oil heating plants should be led to open deck. (8.1) (IACS REC. 58)

10.2.15 Capacity of the thermal oil storage tank shall be sufficient to fill one section of pipelines or the system's element of the greatest volume.

10.2.16 Where the storage tank is also used as a drain tank for the oil from entire system, its capacity shall be sufficient for the containment of the oil plus the volume of thermal oil specified in 10.2.15.

10.2.17 The arrangement of thermal oil system piping shall fulfil the requirements specified in 9.7.

10.2.18 Oil leakage collecting arrangements shall fulfil the requirements specified in 8.6.

10.2.19 The inlet and outlet valves of oil-fired thermal oil heaters and exhaust-fired thermal oil heaters should be controllable from outside the compartment where they are situated. As an alternative, an arrangement for quick gravity drainage of the thermal oil contained in the system into a collecting tank is acceptable. (8.1) (IACS REC. 58)

10.2.20 Thermal oil systems fitted with exhaust gas heaters (boilers) shall be provided with oil cooling arrangements.

10.2.21 Insulation of pipes and elements of thermal oil system shall fulfil the requirements specified in 1.11.

10.2.22 Thermal oil boilers shall fulfil the requirements specified in *Part VII*, 9.14.

10.3 Hydraulic oil systems

10.3.1 The requirements specified below apply to all hydraulic appliances and systems aboard the ship.

Independent appliances, cased in individual housings, fulfilling recognized standards which are not associated with the vessel propulsion, steering and manoeuvring need not fulfil the requirements.

10.3.2 Precautions should be taken to prevent oil spillages from coming into contact with hot surfaces, electrical installations or other sources of ignition.

Hydraulic units with working pressure above 15 bar should preferably be placed in separate spaces. If it is impracticable to locate such units in a separate space, adequate shielding should be provided. (6.2) (IACS REC. 58)

10.3.3 Hydraulic power packs of more than 50 kW with a working pressure more than 10 MPa (100 bar) shall be installed in specially dedicated spaces, provided with a separate ventilation system.

10.3.4 Hydraulic oil shall not be a source of corrosion in the hydraulic system. Its ignition temperature shall not be less than 150°C. Hydraulic oil shall be suitable for working within the range of operating temperatures of the hydraulic arrangement or system. In particular, this regards the range of viscosity change.

10.3.5 Hydraulic pipes shall not be led through cargo holds.

10.3.6 Hydraulic arrangements shall be protected with relief valves. Unless provided otherwise elsewhere in the Rules, the opening pressure of the relief valve shall not exceed 1.1 of the maximum working pressure.

The nominal flow rate of the relief valves shall be so selected that the generated hydraulic oil pressure does not exceed 1.1 of the pre-set pressure of valve opening at the maximum pump output.

10.3.7 In the case of hydraulic systems and appliances working continuously such as hydraulic main propulsion, steering gears, hydrodynamic couplings, the possibility of cleaning oil filters without stopping the system shall be provided.

10.3.8 A failure of the hydraulic system shall not cause damage to the associated piece of machinery or equipment.

10.3.9 Hydraulic systems of steering gears, as well as hydraulic systems actuating variable pitch propellers shall not have any connection with other hydraulic systems.

10.3.10 Where a feed pipe of hydraulic-powered windlasses has a connection to other hydraulic systems, it shall be supplied by two independent pump systems, each of which shall ensure continuous operation of the windlass.

10.3.11 Pipe connections shall fulfil the requirements specified in 1.6.7 and additionally:

- .1** pipes installed on board the vessel shall have the inside surface as clean as it is required for hydraulic components;
- .2** in pipelines with a nominal diameter less than 50 mm, threaded sleeve joints of the type approved by PRS shall be applied; however, the joints with the rubber washer may only be applied for connection of hydraulic components but not for connection of pipe segments;
- .3** pipe joints without PRS approval may only be applied, subject to PRS acceptance in each particular case, where they fulfil the requirements specified in the relevant national standard and are provided with an appropriate inspection certificate;
- .4** pipelines shall not have soldered joints;
- .5** flexible hoses with connection fittings shall be type approved by PRS. Subject to PRS acceptance in each particular case, fireproof hoses without PRS approval may be applied, except in the installations of steering gears and hydraulic control systems of watertight doors, ports and ramps in the vessel shell, provided they fulfil the relevant national standard and have an appropriate inspection certificate.

10.3.12 Hydraulic accumulators shall fulfil the strength requirements for pressure vessels of the particular class. Each accumulator, which may be cut off the hydraulic system shall be provided with an individual relief valve. A safety valve or other protecting device shall be installed on the gas side to prevent overpressure.

10.3.13 Hydraulic cylinders shall fulfil the strength requirements for pressure vessels of the particular class. Hydraulic cylinders shall be type-approved by PRS.

10.3.14 Subject to PRS acceptance in each particular case, hydraulic cylinders which are not type-approved by PRS may be applied if they fulfil the requirements specified in the relevant national standard and are provided with an appropriate inspection certificate.

10.3.15 Valves, pumps, hydraulic motors and high pressure filters shall be type-approved by PRS.

10.3.16 Hydraulic cylinders which do not fulfil the requirements specified in 10.3.11 and 10.3.12 as well as other hydraulic components which do not fulfil the requirement specified in 10.3.13 may be applied if they have been manufactured under PRS survey in accordance with the approved documentation and have been approved by PRS surveyor on the manufacturer's premises in accordance with the approved test programme.

10.3.17 Hydraulic system components in the power actuating or hydraulic servo systems controlling the power systems of the steering gear (e.g. solenoid valves, magnetic valves) shall be considered as part of the steering gear control system and shall be duplicated and separated.

Hydraulic system components in the steering gear control system that are part of a power unit may be regarded as being duplicated and separated when there are two or more separate power units provided and the piping to each power unit can be isolated.

10.3.18 Doors provided to ensure the watertight integrity of internal openings which are used while at sea are to be sliding watertight doors capable of being remotely closed from the bridge and are also to be operable locally from each side of the bulkhead. (...) The power, control and indicators are to be operable in the event of main power failure. Particular attention is to be paid to minimizing the effect of control system failure. Each power-operated sliding watertight door shall be provided with an individual hand-operated mechanism. It shall be possible to open and close the door by hand at the door itself from both sides. (SOLAS, Reg. II-1/13-1.2)

Notes:

1. Hydraulic drives and control systems of sliding watertight doors in passenger ships – see 17.1.1.7 to 17.1.1.15.
2. Electric drives of sliding watertight doors in cargo ships– see *Part VIII*, 5.9 and in passenger ships – see *Part VIII*, 22.1.3.
3. Additional requirements concerning drives and control systems of sliding watertight doors in ships having a mark of subdivision in their symbol of class – see *Part III*, 21.2.1 to 21.2.3.

10.3.19 Tests shall be performed in accordance with the test programme approved by PRS.

10.3.20 Test programme shall determine the type and scope of tests, acceptance criteria, test site and – if necessary – test procedure.

10.3.21 Tests shall include:

- .1 hydrostatic and pressure tests in accordance with the requirements specified in 1.6.8 to 1.6.10;
- .2 post-rinsing check of piping cleanness;
- .3 operating tests;
- .4 hydraulic oil check for impurities before and after operating tests.

CHAPTER 11**11 COOLING WATER SYSTEMS****11.1 Pumps**

11.1.1 Means shall be provided whereby normal operation of propulsion machinery can be sustained or restored even though one of the essential auxiliaries becomes inoperative. Special consideration shall be given to the malfunctioning of:

(...)

.6 the sources of water pressure;

(...)

However, the Administration, having regard to overall safety considerations, may accept a partial reduction in propulsion capability from normal operation. (SOLAS, Reg. II-1/26.3)

11.1.2 The main engines cooling water systems shall fulfil the following requirements:

- .1 Sea-water cooling system of one main engine shall be provided with two pumps, one of which shall be a stand-by pump. The capacity of the stand-by pump shall not be less than that of the main pump. At least one of the pumps shall have independent drive. It is admissible to apply one common, independently driven stand-by pump for both sea and fresh water. The capacity of the pump shall not be less than that of the main pumps. Provision shall be made, however, to prevent the mixing of seawater and fresh water.
- .2 Sea and fresh water cooling systems of two or more engines, may be served by:
 - separate pumps for each engine and in such a case no stand-by pumps are required, or
 - one pump for sea-water system of capacity sufficient for simultaneous cooling of all engines running at maximum load, and one fresh water pump meeting the same requirements. In such a case at least one stand-by pump of capacity not less than that required for every main pump shall be provided.
- .3 In ships of restricted service receiving in their symbol of class additional mark **II** or **III** with one main engine, instead of stand-by fresh water cooling pump, an emergency sea-water cooling may be provided.

11.1.3 For water cooled lubricating oil coolers, fresh water coolers and air coolers of the main electric motors, emergency means of cooling equivalent to the main ones shall be provided.

11.1.4 Where each of the auxiliary engines is provided with a cooling water pump, the stand-by pumps for these engines are not required.

Where for a group of auxiliary engines provision is made for a common cooling system, one stand-by pump for serving both the fresh and sea-water system is sufficient.

11.1.5 Where a common cooling water system for the main and auxiliary engines is provided, separate standby pumps for the auxiliary engines are not required.

11.1.6 For the generating sets, which shall be kept ready for immediate use (hot reserve) provision shall be made for continuous circulation of hot water.

11.1.7 The independent cooling systems of pistons and injection valves, shall be provided with standby pumps having capacity not less than that of main pumps.

11.1.8 Oil coolers of the main turbine sets shall be served by circulating pumps of main condensers.

Where a separate cooling water pump for oil coolers is provided, a stand-by pump with a capacity not less than $2/3$ of the cooling water demand for the cooler at the rated power of the turbine set shall be provided.

For cooling of steam turbines' condensers – see *Chapter 15*.

11.1.9 The ballast, draining and other general service pumps used for the transfer of clean water only may be used as stand-by cooling pumps.

Fire pumps may be used for the purpose, provided the requirements specified in *Part V*, 3.2.2.1 are fulfilled.

11.2 Arrangement of pipes and connections

11.2.1 Sea chests, their valves and fittings shall comply with the requirements of 1.15.

11.2.2 Sea-water supply to the cooling system shall be provided by means of at least two inlet valves, one of which shall be located at the bottom, the other one on the side of the ship. These valves shall be interconnected and the cooling water shall be taken from the connecting sea-water main.

11.2.3 It is recommended that water supply to the cooling system of auxiliary engines and condensers of auxiliary turbines be provided from separate bottom valves. Where such valves are located in the machinery space, suction lines of these systems shall be connected to the sea-water main in accordance with the requirements specified in 11.2.2, and the suction lines shall be fitted with shut-off valves.

11.2.4 In manned machinery spaces, main and auxiliary sea inlets and discharges in connection with the operation of machinery may be controlled locally. The controls shall be readily accessible and shall be provided with indicators showing whether the valves are open or closed. (LL, Annex 1, Reg. II/22(3))

Note:

Valves and fittings of sea inlets and discharges shall comply with the requirements of 2.2.12.

11.2.5 Internal seawater cooling systems shall be designed and made of an appropriate material to minimize biofouling and constructed with a minimum of bends, kinks and flanges in seawater piping in accordance with the guidance contained in IMO Resolution MEPC.207(62).

11.3 Cooling water strainers

11.3.1 Where sea-water is used for the direct cooling of the main engine and auxiliary machinery engines, the cooling water suction pipes shall be provided with strainers. Cleaning the strainers shall not cause stopping the cooling water supply to the engines.

11.4 Cooling of internal combustion engines

11.4.1 In the fresh water cooling system provision shall be made for fresh water expansion tank, in which the level of water shall be higher than the highest level of water in the engine. The expansion tank, which may serve the cooling system of several engines, shall be connected to the suction piping of pumps and shall be fitted with an alarm to give warning on the minimum water level.

11.4.2 Location of a discharge line in the sea-water cooling system of the engines shall ensure covering with water the uppermost cooled areas of engines, water coolers and oil coolers, and shall prevent the formation of stasis.

11.4.3 Where oil fuel or lubricating oil is used in the cooling systems of pistons or injection valves, the requirements specified in *Chapter 8* and *Chapter 9* shall be fulfilled.

11.4.4 The engines of emergency driving systems shall have their own, independent cooling systems.

CHAPTER 12

12 COMPRESSED AIR SYSTEMS

12.1 Starting arrangements of internal combustion engines

IACS UR M61

12.1.1 Mechanical starting arrangements (M61.1)

12.1.1.1 The arrangement for air starting is to be such that the necessary air for the first charge can be produced on board without external aid. (M61.1.1)

Note:

See 12.2 Arrangements for bringing machinery into operation from dead ship condition

12.1.1.2 Where the main engine is arranged for starting by compressed air, two or more air compressors are to be fitted. At least one of the compressors is to be driven independent of the main propulsion unit and is to have the capacity not less than 50% of the total required. (M61.1.2)

12.1.1.3 The total capacity of air compressors is to be sufficient to supply within one hour the quantity of air needed to satisfy 12.1.1.5 (M61.1.5) by charging the receivers from atmospheric pressure. The capacity is to be approximately equally divided between the number of compressors fitted, excluding an emergency compressor which may be installed to satisfy 12.1.1.1 (M61.1.1). (M61.1.3)

12.1.1.4 Where the main engine is arranged for starting by compressed air, at least two starting air receivers of about equal capacity are to be fitted which may be used independently. (M61.1.4)

12.1.1.5 The total capacity of air receivers is to be sufficient to provide, without their being replenished, not less than 12 consecutive starts alternating between Ahead and Astern of each main engine of the reversible type, and not less than six starts of each main non-reversible type engine connected to a controllable pitch propeller or other device enabling the start without opposite torque. When other consumers such as auxiliary engines starting systems, control systems, whistle, etc., are to be connected to starting air receivers, their air consumption is also to be taken into account.

Regardless of the above, for multi-engine installations the number of starts required for each engine may be reduced upon the agreement with the Classification Society depending upon the arrangement of the engines and the transmission of their output to the propellers.

(...) (M61.1.5)

Note:

Remaining part of this UR M61 – electrical starting of internal combustion engines – see *Part VIII*, 13.7.2.2.

END OF IACS UR M61

12.1.2 Air compressors shall be installed in such places where the contamination by flammable liquid vapours of air drawn by the compressor is as low as possible.

12.1.3 Means shall be provided whereby normal operation of propulsion machinery can be sustained or restored even though one of the essential auxiliaries becomes inoperative. Special consideration shall be given to the malfunctioning of:

(...)

.9 an air compressor and receiver for starting or control purposes;

(...)

However, the Administration, having regard to overall safety considerations, may accept a partial reduction in propulsion capability from normal operation. (SOLAS, Reg. II-1/26.3)

12.1.4 Compressed air system for starting the main engine(s) shall be so designed as to enable simultaneous starting and reversing of all main engines.

12.1.5 The main starting air arrangements for main propulsion internal combustion engines shall be adequately protected against the effects of backfiring and internal explosion in the starting air pipes. (SOLAS, Reg. II-1/34.2)

12.1.6 In order to protect starting air mains against explosion arising from improper functioning of starting valves, the following devices must be fitted:

- (i) an isolation non-return valve or equivalent at the starting air supply connection to each engine
- (ii) a bursting disc or flame arrester in way of the starting valve of each cylinder for direct reversing engines having a main starting manifold at the supply inlet to the starting air manifold for non-reversing engines.

Devices under (ii) above may be omitted for engines having a bore not exceeding 230 mm. (IACS UR M11)

12.1.7 All discharge pipes from starting air compressors shall lead directly to the starting air receivers, and all starting pipes from the air receivers to main or auxiliary engines shall be entirely separate from the compressor discharge pipe system. (SOLAS, Reg. II-1/34.3)

12.1.8 Each of the starting air receivers shall be capable of being charged from each of the main compressors.

12.1.9 In ships of restricted service instead of a compressor driven by the main engine (see 12.1.1.2), arrangements for charging the starting air receivers from the main engine cylinders may be applied.

In ships of restricted service receiving in their symbol of class additional mark **III**, a single arrangement for charging starting air receivers may be applied subject to PRS consent in each particular case.

The capacity of the compressor or throughput of the charging valves fitted on the cylinders shall fulfil the requirements specified in 12.1.1.3.

12.1.10 The temperature of compressed air entering the receiver from the charging valve on the engine shall not exceed 90°C. Where necessary, provision shall be made for an air cooler. The pipes used for charging the receivers shall not be led under the floor plates.

12.1.11 For starting the auxiliary engines, provision shall be made for a separate compressed air receiver of a capacity sufficient to provide 6 starts of the biggest engine ready for operation. In addition to the above, the following requirements shall be fulfilled:

- provision shall be made for the possibility of starting the auxiliary engines from one of the air receivers serving the main engines, or
- the required amount of compressed air shall be stored in two receivers, each having capacity sufficient to provide 3 starts.

PRS may waive the requirement for installing separate receiver for starting the auxiliary engines, provided that the requirement specified in 12.1.11 is fulfilled.

12.1.12 Compressed air receiver or group of receivers for starting main engine(s) may provide air for starting the auxiliary engines, for supplying the whistle or for other purposes, provided that:

- the capacity of the air receivers is increased respectively and
- automatic topping-up of the compressed air receivers is provided,

or

- provision is made for an alarm to give warning in the case of pressure drop of not more than 0.5 MPa below the working pressure of the compressed air receivers.

12.1.13 The starting air receiver for auxiliary engines, specified in 12.1.10 may be topped-up from the receivers specified in 12.1.11, however, provision shall be made to prevent air flow in the opposite direction.

12.1.14 In the event of failure of one of the compressors required in 12.1.1.2, the capacity of the other shall not be less than that required in 12.4.6 for the whistle.

12.1.15 Starting arrangements in periodically unattended machinery spaces comply with additional requirements provided in 18.3.7.

12.2 Arrangements for bringing machinery into operation from dead ship condition

12.2.1 Means shall be provided to ensure that the machinery can be brought into operation from the dead ship condition without external aid. (SOLAS, Reg. II-1/26.4)

*** IACS interpretation:**

- 1. Dead ship condition for the purpose of 12.2.1 (regulation II-1/26.4), is to be understood to mean a condition under which the main propulsion plant, boilers and auxiliaries are not in operation and in restoring the propulsion, no stored energy for starting and operating the propulsion plant, the main source of electrical power and other essential auxiliaries is assumed to be available. (compare with 1.2.22)*
- 2. Where the emergency source of power is an emergency generator which complies with regulation II-1/44, UI SC185 and UI SC124, this generator may be used for restoring operation of the main propulsion plant, boilers and auxiliaries where any power supplies necessary for engine operation are also protected to a similar level as the starting arrangements.*
- 3. Where there is no emergency generator installed or an emergency generator does not comply with regulation II-1/44, the arrangements for bringing main and auxiliary machinery into operation are to be such that the initial charge of starting air or initial electrical power and any power supplies for engine operation can be developed on board ship without external aid. If for this purpose an emergency air compressor or an electric generator is required, these units are to be powered by a hand-starting oil engine or a hand-operated compressor. The arrangements for bringing main and auxiliary machinery into operation are to have capacity such that the starting energy and any power supplies for engine operation are available within 30 minutes of a dead ship condition. (IACS UI SC184)*

12.2.2 A hand driven compressor or a compressor set with hand starting internal combustion engine which may be used to enable starting of the engines from the dead ship condition shall charge with air a separate receiver of a capacity sufficient to provide 3 starts of one generating set or one main compressor, if the compressor is driven by an internal combustion engine.

A separate air receiver is not required where the hand or engine driven compressor is capable of charging the air receiver mentioned in 12.1.8 within 1 hour.

12.3 Starting arrangements for emergency generating sets

12.3.1 Each emergency generating set arranged to be automatically started shall be equipped with starting devices approved by the Administration with a stored energy capability of at least three consecutive starts. (...) (SOLAS, Reg. II-1/44.2)

Note:

IACS UI SC185 and MSC/Circ.736 are technically identical with the present Reg. II-1/44.2, hence they are not repeated.

12.3.2 The source of stored energy shall be protected to preclude critical depletion by the automatic starting system, unless a second independent means of starting is provided. In addition, a second source of energy shall be provided for an additional three starts within 30 minutes unless manual starting can be demonstrated to be effective. (SOLAS, Reg. II-1/44.2.1)

12.3.3 The stored energy shall be maintained at all times, as follows:

- .1 (...);
- .2 compressed air starting systems may be maintained by the main or auxiliary compressed air receivers through a suitable non-return valve or by an emergency air compressor which, if electrically driven, is supplied from the emergency switchboard;
- .3 all of these starting, charging and energy storing devices shall be located in the emergency generator space; these devices are not to be used for any purpose other than the operation of the emergency generating set. This does not preclude the supply to the air receiver of the emergency generating set from the main or auxiliary compressed air system through the non-return valve fitted in the emergency generator space. (SOLAS, Reg. II-1/44.3)

12.4 Arrangement of pipes and connections

12.4.1 In every ship means shall be provided to prevent overpressure in any part of compressed air systems and wherever water jackets or casings of air compressors and coolers might be subjected to dangerous overpressure due to leakage into them from air pressure parts. Suitable pressure relief arrangements shall be provided for all systems. (SOLAS, Reg. II-1/34.1)

12.4.2 The cross-sectional area of pipes discharging the compressed air from safety valves or fusible plugs outside the machinery space shall not be less than twice the free area of the valve or plug.

The pipes shall be provided with water draining arrangements.

12.4.3 A non-return shut-off valve shall be fitted in the discharge pipe of each compressor.

12.4.4 Provision shall be made to reduce to a minimum the entry of oil into the air pressure systems and to drain these systems. (SOLAS, Reg. II-1/34.4)

12.4.5 Drainage cocks shall be fitted on the compressed air receivers and on the lowest positioned pipes of these systems.

12.4.6 Where special air receiver is fitted for the whistle, its capacity shall be sufficient to enable the whistle to work continuously for 2 minutes and hourly capacity of the air compressor shall not be less than that required to provide 8 minutes operation of the whistle.

12.4.7 Where it is intended to take air from the receiver provided for the whistle, the capacity of the receiver shall be increased accordingly and automatic topping-up or an alarm device warning in the case when the amount of air in the receiver reaches the lower limit required for the whistle shall be arranged.

CHAPTER 13

13 BOILER FEED WATER SYSTEM

13.1 Pumps

13.1.1 Means shall be provided whereby normal operation of propulsion machinery can be sustained or restored even though one of the essential auxiliaries becomes inoperative. Special consideration shall be given to the malfunctioning of:

(...)

.3 the boiler feed water systems;

(...)

However, the Administration, having regard to overall safety considerations, may accept a partial reduction in propulsion capability from normal operation. (SOLAS, Reg. II-1/26.3)

13.1.2 Every steam generating system which provides services essential for the safety of the ship, or which could be rendered dangerous by the failure of its feed water supply, shall be provided with not less than two separate feed water systems from and including the feed pumps, noting that a single penetration of the steam drum is acceptable. Unless overpressure is prevented by the pump characteristics means shall be provided which will prevent overpressure in any part of the systems. (SOLAS, Reg. II-1/32.4)

IACS interpretation

Where a steam generation system consists of two or more adequately sized boilers, and the feed water for each of these boilers is supplied by a single feed water pipe, the level of redundancy for the piping of the feedwater system is considered to comply with 13.1.2 (SOLAS II-1/32.4). (IACS UI SC232)

13.1.3 The capacity of each of the pumps required under 13.1.2 shall be sufficient for boiler operation at the rated service conditions.

13.1.4 Auxiliary boilers providing services non-essential for the safety of the ship and unfired boilers (exhaust gas economizers) of a construction which enables them to be kept without water when heated with exhaust gases, may be provided with one feedwater system/pump.

13.1.5 Where more than two feed pumps are fitted, then with one of the pumps being out of service the combined capacity of the other shall not be less than the capacity specified above for one feed pump.

13.1.6 Steam supply to the steam-driven feed pumps shall be provided by means of a separate pipeline and shall be possible from each boiler served by these pumps.

13.1.7 Main boilers and auxiliary boilers providing services essential for the safety of the ship with forced water circulation shall be fitted with at least two circulating pumps, one of them being a stand-by pump.

13.2 Arrangement of pipes and connections

13.2.1 In the case of open circuit feed system provision shall be made to enable the feed pumps to take water from the hot wells and from the feed water storage tanks.

13.2.2 Boilers shall be provided with means to supervise and control the quality of the feed water. Suitable arrangements shall be provided to preclude, as far as practicable, the entry of oil or other contaminants which may adversely affect the boiler. (SOLAS, Reg. II-1/32.5)

13.2.3 Feed water pipes may be led through oil tanks only in tight tunnels forming an integral part of the tanks.

13.2.4 The feed water system of main boilers and auxiliary boilers providing services essential for the safety of the ship shall be provided with automatic salinometer.

13.3 Tanks

13.3.1 Feed water tanks shall be separated from oil fuel, lubricating oil and vegetable oil tanks by cofferdams complying with the requirements specified in *Part II*, 9.2.4.1.

CHAPTER 14

14 STEAM SYSTEM, BOILER SCUM AND BLOW-DOWN SYSTEM

14.1 Arrangement of pipes and connections

14.1.1 Every steam pipe and every fitting connected thereto through which steam may pass shall be so designed, constructed and installed as to withstand the maximum working stresses to which it may be subjected. (SOLAS, Reg. II-1/33.1)

14.1.2 Steam pipes, valves and fitting shall not be made of grey cast iron.

14.1.3 The mean radius of bend of the boiler blow down pipes shall not be less than $3.5d$ (d – outside diameter of the pipe).

14.1.4 The machinery connected to the steam pipes shall be protected against stress due to thermal expansion of the pipes, by making appropriate pipe bends (self-compensation) or by fitting expansion joints in appropriate positions (see also 1.10.15).

14.1.5 If a steam pipe or fitting may receive steam from any source at a higher pressure than that for which it is designed a suitable reducing valve, relief valve and pressure gauge shall be fitted. (SOLAS, Reg. II-1/33.3)

Note:

See also 1.13.

14.1.6 The steam pipelines in the engine and boiler rooms shall be led in the upper parts of these spaces, where practicable, in a position accessible for inspection and servicing.

14.1.7 Except for the heating and boiler scum and blow-down pipes, leading the steam pipes under the floor plates of the engine and boilers rooms is not allowed.

14.1.8 The steam pipes shall not be led in the vicinity of the oil fuel tanks.

14.1.9 Steam pipes shall not be led through the paint stores, lantern rooms and other spaces intended for the carriage of flammable substances.

14.1.10 Steam pipes shall not be led through the cargo holds.

14.1.11 Where two or more boilers are interconnected, non-return valves shall be fitted at each boiler before the manifold. These valves need not be installed where shut-off non-return valves are fitted on the boilers.

14.1.12 The pipes from scum and blow-down valves of two or more boilers may be connected to a common discharge pipe, provided that non-return valves are fitted in these pipes before the common discharge pipe.

14.1.13 Steam for the ship's whistle shall be supplied through a separate pipe directly from the main boiler. This requirement does not apply to ships having pneumatically or electrically operated sound signalling means, in addition to the steam whistle.

14.1.14 Where piping system for steaming oil fuel tanks and oil cargo tanks is provided, shut-off non-return valve shall be fitted on each tank.

14.2 Draining of steam pipelines



14.2.1 Means shall be provided for draining every steam pipe in which dangerous water hammer action might otherwise occur. (SOLAS, Reg. II-1/33.2)

14.2.2 In the case of open drain pipes system for the steam pipelines, the drain pipes shall be led below the floor plates.

CHAPTER 15

15 CONDENSATE SYSTEM AND STEAM SUPPLY SYSTEM FOR STEAM TURBINES

15.1 General requirements for condensate system

15.1.1 Means shall be provided whereby normal operation of propulsion machinery can be sustained or restored even though one of the essential auxiliaries becomes inoperative. Special consideration shall be given to the malfunctioning of:

(...)

.7 a condensate pump and the arrangements to maintain vacuum in condensers;

(...)

However, the Administration, having regard to overall safety considerations, may accept a partial reduction in propulsion capability from normal operation. (SOLAS, Reg. II-1/26.3)

15.1.2 Each main turbine set shall be fitted with its own condensate system ensuring a stable vacuum under all rated conditions of service.

15.1.3 The auxiliary turbines may have a common condensate system. With the ship under way, waste steam from the auxiliary turbo-generators may be discharged into the main condenser or into the stages of the main turbine set.

15.2 Cooling water and condensate pumps

15.2.1 The condensate system of the main steam turbine shall be fitted with two independent cooling water pumps – one main and one stand-by pump.

15.2.2 The capacity of the stand-by pump shall not be less than 0.3 of the rated demand for cooling water. Any pump of sufficient capacity may be used as a stand-by pump.

15.2.3 In twin-propeller ships, application of only one stand-by cooling water pump for both turbine sets is permitted.

15.2.4 Where provision is made for cooling the main condenser by simultaneous operation of two pumps, each having a capacity not less than 0.5 of the rated demand for water, the stand-by cooling water pump is not required.

15.2.5 Where the auxiliary condenser is common for all auxiliary turbines, it shall be served by two independent cooling water pumps – one main and one stand-by pump. Any pump of sufficient capacity may be used as a stand-by pump.

15.2.6 The condensate system of the steam turbines shall be fitted with two independent condensate pumps – one main and one stand-by pump. The capacity of each pump shall be at least 1.25 of the maximum amount waste steam delivered to the condenser. In systems with two main condensers arranged in one engine room, the stand-by condensate pump may be common for both condensers.

15.3 Arrangement of pipes and connections

15.3.1 Arrangement of condenser's cooling water pipes and connections shall fulfil the requirements specified in *Section 11.2* and *11.3*.

15.3.2 The condensate collector, discharge pipe and the condensate pump shall be so arranged in respect to each other as to preclude the flooding of the lower rows of pipes and to ensure smooth drainage of condensate to the pump. The handhole for cleaning the collector shall be provided.

15.3.3 The nozzles of the ejectors of the condensate system shall be protected against damage and clogging. For this purpose, a protective metal wire net shall be installed in the steam pipe.

15.4 Steam supply to steam turbines

15.4.1 Steam pipes, valves and fitting shall not be made of grey cast iron.

15.4.2 For pipes with an outside diameter of 80 mm and above, conveying superheated steam at a temperature 350°C and over, additional stress caused by thermal expansion shall be taken into account, and the flanged joints shall be calculated for strength and tightness.

15.4.3 Safety arrangements for steam supply to steam turbines

IACS UR M26

15.4.3.1 Governors and speed control (1)

15.4.3.1.1 Arrangement is to be provided for shutting off the steam to the main turbines by suitable hand trip gear situated at the manoeuvring stand and at the turbine itself.

Hand tripping for auxiliary turbines is to be arranged in the vicinity of the turbine overspeed protective device. **(M26.1.2)**

NOTE

The hand trip gear is understood as any device which is operated manually irrespective of the way the action is performed, i.e. mechanically or by means of external power.

15.4.3.1.2 Where exhaust steam from auxiliary systems is led to the main turbine it is to be cut off at activation of the overspeed protective device. **(M26.1.4)**

15.4.3.2 Miscellaneous safety arrangements (2)

15.4.3.2.1 Main ahead turbines are to be provided with a quick acting device which will automatically shut off the steam supply in the case of dangerous lowering of oil pressure in the bearing lubricating system. This device is to be so arranged as not to prevent the admission of steam to the astern turbine for braking purposes.

Where deemed necessary by the Classification Society appropriate means are to be provided to protect the turbines in case of:

- abnormal axial rotor displacement,
- excessive condenser pressure,
- high condensate level. **(M26.2.1)**

15.4.3.2.2 Auxiliary turbines having governors operated other than hydraulically in which the lubricating oil is inherent in the system, are to be provided with an alarm device and a means of shutting off the steam supply in the case of lowering of oil pressure in the bearing lubricating oil system. **(M26.2.2)**

15.4.3.2.3 To provide a warning to personnel in the vicinity of the exhaust end steam turbines of excessive pressure, a sentinel valve or equivalent is to be provided at the exhaust end of all

turbines. The valve discharge outlets are to be visible and suitably guarded if necessary. When, for auxiliary turbines, the inlet steam pressure exceeds the pressure for which the exhaust casing and associated piping up to exhaust valve are designed, means to relieve the excess pressure are to be provided. **(M26.2.4)**

15.4.3.2.4 Non-return valves, or other approved means which will prevent steam and water returning to the turbines, are to be fitted in bled steam connections. **(M26.2.5)**

15.4.3.2.5 Efficient steam strainers are to be provided close to the inlets to ahead and astern high pressure turbines or alternatively at the inlets to manoeuvring valves. **(M26.2.6)**

Note:

Remaining requirements of this UR M26 – see 9.5.3 and *Part VII*, 3.2.6.

END OF IACS UR M26

CHAPTER 16**16 SANITARY DRAINAGE SYSTEM****16.1 General requirements**

16.1.1 Ships engaged in international voyages, which fulfil at least one of the following conditions:

- 400 gross tonnage and above,
- certified to carry more than 15 persons,

shall be fitted with gravity or vacuum sanitary drainage system.

16.1.2 Ships other than those mentioned in 16.1.1 fitted with sanitary drainage system shall fulfil all requirements of this *Chapter 16* unless provided otherwise.

16.1.3 Gravity systems drain pipes shall slope in the direction of discharge so as to ensure that, under list and trim conditions expected during normal service, the sanitary drainage will not remain in the pipes.

16.1.4 All sanitary utensils, sinks, laundry tubes, scuppers, etc. connected to the gravity drain system shall be fitted with water seals.

16.1.5 Gravity systems drain pipes shall be fitted with air pipes led from the main vertical drains, as well as from the places most distant from the main vertical drains. The number, arrangement and diameter of air pipes shall be such as to prevent water from being sucked from water seals by the sanitary drainage flowing away.

16.1.6 The air pipes shall terminate away from doors, the opening type windows, inlets to ventilation systems, etc. so as to prevent the escaping gases from entering the spaces where people may be present.

16.1.7 Air pipes shall fulfil the relevant requirements specified in 5.1 to 5.3.

16.1.8 The direct overboard discharge pipes of sanitary drainage shall fulfil the relevant requirements specified in 2.2.

16.2 Sewage system

16.2.1 Every ship which, in accordance with regulation 2, is required to comply with the provisions of this Annex (ships defined in 16.1.1) shall be equipped with one of the following sewage systems:

- .1** a sewage treatment plant which shall be of a type approved by the Administration, taking into account the standards and test methods developed by the Organization *, or

* Refer to the *Recommendation on International effluent standards and guidelines for performance tests for sewage treatment plants* (resolution MEPC.2(VI)), *Revised guidelines on implementation of effluent standards and performance tests for sewage treatment plants* (resolution MEPC.159(55)) (see Unified Interpretation 3), or *2012 Guidelines on implementation of effluent standards and performance tests for sewage treatment plants* (resolution MEPC.227(64)).

- .2** a sewage comminuting and disinfecting system approved by the Administration. Such system shall be fitted with facilities to the satisfaction of the Administration, for the

temporary storage of sewage when the ship is less than 3 nautical miles from the nearest land, or

- .3 a holding tank of the capacity to the satisfaction of the Administration for the retention of all sewage, having regard to the operation of the ship, the number of persons on board and other relevant factors. The holding tank shall be constructed to the satisfaction of the Administration and shall have a means to indicate visually the amount of its contents. (MARPOL, Reg. IV/9.1)

Notes:

1. For newly installed sewage treatment plants on ships other than passenger ships operating in special areas IMO resolution MEPC.227(64) applies.
2. For newly installed sewage treatment plants on passenger ships operating in special areas IMO resolution MEPC.227(64) as amended by MEPC.274(69) applies.

16.2.2 By derogation from 16.2.1 (paragraph 1), every passenger ship which, in accordance with regulation 2 (ships defined in 16.1.1), is required to comply with the provisions of this Annex, and for which regulation 11.3 applies while in a special area, shall be equipped with one of the following sewage systems:

- .1 a sewage treatment plant which shall be of a type approved by the Administration, taking into account the standards and test methods developed by the Organization, or
- .2 a holding tank of the capacity to the satisfaction of the Administration for the retention of all sewage, having regard to the operation of the ship, the number of persons on board and other relevant factors. The holding tank shall be constructed to the satisfaction of the Administration and shall have a means to indicate visually the amount of its contents. (MARPOL, Reg. IV/9.2)

Note:

Regulation 11.3 applies to the discharge of sewage from passenger ships while in a special area.

16.2.3 Capacity of the sewage treatment plant shall be sufficient for the number of persons the ship is certified to carry, having regard to the manufacturer's guidelines.

16.2.4 Where sewage (blackwater) and greywater systems are separate, the holding tank is required for sewage only. In the case of combined system, holding tank shall enable retention of both blackwater and greywater. Capacity V of the holding tank shall be determined in accordance with the following formula:

$$V = 0.001qnt \quad [\text{m}^3]$$

where:

- q – amount of drained water, in litres, per person per day. For blackwater only, 70 l per person per day shall be assumed, for greywater and blackwater (combined system) 230 l per person per day shall be assumed. In the case of vacuum systems, 25 l per person per day and 185 l per person per day respectively shall be assumed, unless otherwise specified by the manufacturer of the system;
- n – maximum number of persons the ship is certified to carry;
- t – time, in days, of the ship's stay in port and/or operation in the area where sanitary drainage shall not be discharged in accordance with the provisions of MARPOL Convention, Annex IV. Normally it shall not be shorter than 3 days. Where, apart from the holding tank, a sewage treatment plant is also provided, to calculate the tank capacity, $t = 2$ days may be assumed. For passenger ships engaged on voyages lasting up to 4 hours, the tank capacity may be reduced to 30% of the value calculated in accordance with the above formula and where the voyage duration does not exceed 2 hour – up to 10%.

16.2.5 Ballast tanks shall not be used as holding tanks.

16.2.6 The holding tank shall not have common boundaries with accommodation spaces, food storerooms and tanks other than ballast tanks, heavy fuel oil storage tanks, oil residues tanks or tanks intended for other liquid wastes. Where the holding tank forms integral part of the ship structure, the surrounding cofferdams shall fulfil the requirements specified in *Part II*, 9.2.4.1.

16.2.7 The holding tank shall be provided with an alarm device set at 75% and 100% of the tank capacity.

16.2.8 The holding tank shall be fitted with water washing system. It is recommended that stiffeners be provided on the outside of the tank.

16.2.9 Sewage treatment plants and holding tanks provided with internal partitions shall be fitted with air pipes led from chambers to which the inlet pipes are connected, unless construction of the partitions does not require such an arrangement.

16.2.10 It shall be possible to discharge the sewage treatment plant and holding tank's content to shore reception facilities through the standard discharge connection referred to in 16.2.11 or 16.2.12.

16.2.11 To enable pipes of reception facilities to be connected with the ship's discharge pipeline, both lines shall be fitted with a standard discharge connection in accordance with the following table:

Standard dimensions of flanges for discharge connections

Description	Dimension
Outside diameter	210 mm
Inner diameter	According to pipe outside diameter
Bolt circle diameter	170 mm
Slots in flange	4 holes 18 mm in diameter equidistantly placed on a bolt circle of the above diameter, slotted to the flange periphery. The slot width to be 18 mm
Flange thickness	16 mm
Bolts and nuts: quantity and diameter	4, each of 16 mm in diameter and of suitable length
The flange is designed to accept pipes up to a maximum internal diameter of 100 mm and shall be of steel or other equivalent material having a flat face. This flange, together with a suitable gasket, shall be suitable for a service pressure of 600 kPa.	

IACS interpretation

All ships subject to Annex IV, irrespective of their size and of the presence of a sewage treatment plant or sewage holding tank, shall be provided with a pipeline and the relevant shore connection flange for discharging sewage to port sewage treatment facility. (IACS UI MPC86)

For ships having a moulded depth of 5 metres and less, the inner diameter of the discharge connection may be 38 millimetres. (MARPOL, Reg. IV/10.1)

16.2.12 For ships in dedicated trades, i.e. passenger ferries, alternatively the ship's discharge pipeline may be fitted with a discharge connection which can be accepted by the Administration, such as quick connection couplings. (MARPOL, Reg. IV/10.2)

16.2.13 The standard discharge connection shall be installed on deck and so located as to enable easy connection of the reception hose from each shipside. The discharge connection shall be fitted with a blank flange and nameplate marked "Sewage" or "Blackwater".

16.2.14 Where sewage treatment plant installed on board employs a biological treatment process, greywater and blackwater systems shall be separated. Sewage shall be led to the first stage of the plant whereas greywater – to the last stage (disinfection chamber).

16.2.15 On the effluent discharge pipe from the sewage treatment plant as well as on the discharge pipe from the comminuting and disinfecting system sampling cocks shall be fitted.

16.2.16 Where the ship is provided with a system for the discharge into the sea of the content of holding tank, the side discharge valve shall be provided with nameplate marked: "Untreated sewage (blackwater). Keep the valve closed within 12 nautical miles from the nearest land".

Such a plate shall also be affixed at the side valves of blackwater direct overboard discharge.

16.2.17 For the discharge of holding tank content a pump of proper type and parameters shall be provided having regard to the characteristics of the liquid being pumped, the size and the position of the tank and the overall discharge time.

CHAPTER 17

17 ADDITIONAL REQUIREMENTS FOR SPECIFIC SHIP TYPES

17.1 Passenger ships – additional marks: PASSENGER SHIP, PASSENGER SHIP (FERRY)

Notes:

1. Passenger ships having vehicle or special category spaces and receiving in their symbol of class supplementary mark **RO-RO** shall also comply with additional requirements specified in 17.1.6.
2. Passenger ships engaged on domestic voyages and receiving in their symbol of class supplementary mark **Class A**, **Class B**, **Class C** or **Class D** shall comply with 17.1.7 instead of compliance with 17.1.1 to 17.1.5.
3. Passenger ships of 120 m in length or more, or having 3 or more main vertical zones and receiving in their symbol of class additional mark **SRP** shall also comply with 17.1.8.

17.1.1 Openings and penetrations in watertight boundaries below the bulkhead deck in passenger ships

17.1.1.1 The number of openings in watertight boundaries shall be reduced to the minimum compatible with the design and proper working of the ship; satisfactory means shall be provided for closing these openings. (SOLAS Reg. II-1/13.1)

17.1.1.2 Where pipes, scuppers, (...) etc., are carried through watertight boundaries, arrangements shall be made to ensure the watertight integrity of the boundaries. (SOLAS Reg. II-1/13.2.1)

17.1.1.3 Valves not forming part of a piping system shall not be permitted in watertight boundaries. (SOLAS Reg. II-1/13.2.2)

17.1.1.4 Lead or other heat sensitive materials shall not be used in systems which penetrate watertight boundaries, where deterioration of such systems in the event of fire would impair the watertight integrity of the boundaries. (SOLAS Reg. II-1/13.2.3)

IACS and IMO interpretation

1. Any penetration used for the passage of heat-sensitive piping systems through a watertight bulkhead or deck on a passenger ship under SOLAS regulation II-1/13.2.3 shall be tested with the heat-sensitive piping and should be type-approved for watertight integrity as per paragraphs 4 and 5 of the explanatory notes to regulation II-1/13.2.3 contained in the annex of resolutions MSC.429(98)/Rev.2, as applicable, after the fire test.
2. SOLAS regulation II-1/13.2.3 shall be applicable to heat-sensitive piping systems and shall not be applied to cable penetrations in watertight bulkheads and decks. (IACS UI SC299, MSC.1/Circ.1362)

17.1.1.5 No doors, (...) are permitted in watertight transverse bulkheads dividing a cargo space from an adjoining cargo space, except as provided in 17.1.1.6 (paragraph 8.1) and in regulation 14 (passenger ships carrying goods vehicles and accompanying personnel). (SOLAS Reg. II-1/13.3)

17.1.1.6 If the Administration is satisfied that such doors are essential, watertight doors of satisfactory construction may be fitted in watertight bulkheads dividing cargo spaces on 'tween decks. Such doors may be hinged, rolling or sliding doors but shall not be remotely controlled. (...). (SOLAS Reg. II-1/13.8.1)

17.1.1.7 Watertight doors (...) shall be power-operated sliding doors complying with the requirements of 17.1.1.10 to 17.1.1.12 (paragraph 6). (SOLAS Reg. II-1/13.5.1)

17.1.1.8 The means of operation whether by power or by hand of any power-operated sliding watertight door shall be capable of closing the door with the ship listed to 15° either way. Consideration shall also be given to the forces which may act on either side of the door as may be

experienced when water is flowing through the opening applying a static head equivalent to a water height of at least 1 m above the sill on the centreline of the door. (SOLAS Reg. II-1/13.5.2)

17.1.1.9 Watertight door controls, including hydraulic piping and electric cables, shall be kept as close as practicable to the bulkhead in which the doors are fitted, in order to minimize the likelihood of them being involved in any damage which the ship may sustain. The positioning of watertight doors and their controls shall be such that if the ship sustains damage within one fifth of the breadth of the ship, as defined in 1.2.6 (regulation 2), such distance being measured at right angles to the centreline at the level of the deepest subdivision draught, the operation of the watertight doors clear of the damaged portion of the ship is not impaired. (SOLAS Reg. II-1/13.5.3)

17.1.1.10 Each power-operated sliding watertight door:

(...)

.3 shall be fitted with the necessary equipment to open and close the door using electric power, hydraulic power, or any other form of power that is acceptable to the Administration;

Note:

Electric drives and equipment of sliding watertight doors in passenger ships – see *Part VIII*, 22.1.3.

.4 shall be provided with an individual hand-operated mechanism. It shall be possible to open and close the door by hand at the door itself from either side, and in addition, close the door from an accessible position above the bulkhead deck with an all round crank motion or some other movement providing the same degree of safety acceptable to the Administration. Direction of rotation or other movement is to be clearly indicated at all operating positions. The time necessary for the complete closure of the door, when operating by hand gear, shall not exceed 90 s with the ship in the upright position. Visual indicators to show whether the door is open or closed shall be provided at the accessible position above the bulkhead deck;

.5 shall be provided with controls for opening and closing the door by power from both sides of the door and also for closing the door by power from the central operating console(s) required by 17.1.1.14 (paragraph 7.1);

(...)

.7 shall have an approximately uniform rate of closure under power. The closure time, from the time the door begins to move to the time it reaches the completely closed position shall in no case be less than 20 s or more than 40 s with the ship in the upright position. (SOLAS Reg. II-1/13.6.1)

17.1.1.11 Power-operated sliding watertight doors shall have either:

.1 a centralized hydraulic system with two independent power sources each consisting of a motor and pump capable of simultaneously closing all doors. In addition, there shall be for the whole installation hydraulic accumulators of sufficient capacity to operate all the doors at least three times, i.e. closed-open-closed, against an adverse list of 15°. This operating cycle shall be capable of being carried out when the accumulator is at the pump cut-in pressure. The fluid used shall be chosen considering the temperatures liable to be encountered by the installation during its service. The power operating system shall be designed to minimize the possibility of having a single failure in the hydraulic piping adversely affect the operation of more than one door. The hydraulic system shall be provided with a low-level alarm for hydraulic fluid reservoirs serving the power-operated system and a low gas pressure alarm or other effective means of monitoring loss of stored

energy in hydraulic accumulators. These alarms are to be audible and visual and shall be situated on the central operating console(s) required by 17.1.1.13 (paragraph 7.1); or

- .2 an independent hydraulic system for each door with each power source consisting of a motor and pump capable of opening and closing the door. In addition, there shall be a hydraulic accumulator of sufficient capacity to operate the door at least three times, i.e. closed-open-closed, against an adverse list of 15°. This operating cycle shall be capable of being carried out when the accumulator is at the pump cut-in pressure. The fluid used shall be chosen considering the temperatures liable to be encountered by the installation during its service. A low gas pressure group alarm or other effective means of monitoring loss of stored energy in hydraulic accumulators shall be provided at the central operating console(s) required by 17.1.1.13 (paragraph 7.1). Loss of stored energy indication at each local operating position shall also be provided; or
- .3 an independent electrical system and motor for each door (...)

For the systems specified in 17.1.1.11.1, 17.1.1.11.2 and 17.1.1.11.3 (paragraphs 6.3.1, 6.3.2 and 6.3.3) provision should be made as follows: Power systems for power-operated watertight sliding doors shall be separate from any other power system. A single failure in the electric or hydraulic power-operated systems excluding the hydraulic actuator shall not prevent the hand operation of any door. (SOLAS Reg. II-1/13.6.3)

17.1.1.12 Control handles shall be provided at each side of the bulkhead at a minimum height of 1.6 m above the floor and shall be so arranged as to enable persons passing through the doorway to hold both handles in the open position without being able to set the power closing mechanism in operation accidentally. The direction of movement of the handles in opening and closing the door shall be in the direction of door movement and shall be clearly indicated. (SOLAS Reg. II-1/13.6.4)

17.1.1.13 A central operating console for all power-operated sliding watertight doors shall be located in the safety centre in accordance with regulation II-2/23 (see Part V, 11.1.17). If the safety centre is located in a separate space adjacent to the navigation bridge, a central operating console shall also be located on the navigation bridge. The central operating console(s) shall have a "master mode" switch with two modes of control: a "local control" mode which shall allow any door to be locally opened and locally closed after use without automatic closure, and a "doors closed" mode which shall automatically close any door that is open in not more than 60 s with the ship in an upright position. The "doors closed" mode shall permit doors to be opened locally and shall automatically re-close the doors upon release of the local control mechanism. The "master mode" switch shall normally be in the "local control" mode. The "doors closed" mode shall only be used in an emergency or for testing purposes. (SOLAS Reg. II-1/13.7.1)

17.1.1.14 It shall not be possible to remotely open any door from the central operating console. (SOLAS Reg. II-1/13.7.4)

17.1.1.15 Drives and control systems of sliding watertight doors in passenger ships having mark [P] of subdivision in their symbol of class shall also comply with the relevant requirements of Part III, 21.2.1.

17.1.2 Internal watertight integrity of passenger ships above the bulkhead deck

17.1.2.1 (...) Where (...), pipes, scuppers, (...) etc. are carried through internal watertight boundaries that are immersed at any intermediate or final stage of flooding in damage cases (...) arrangements shall be made to ensure their watertight integrity. (SOLAS Reg. II-1/17.2)

17.1.2.2 (...) scuppers shall be fitted as necessary for rapidly clearing the weather deck of water under all weather conditions. (SOLAS Reg. II-1/17.4)

17.1.2.3 Air pipes terminating within a superstructure which are not fitted with watertight means of closure shall be considered as unprotected openings (...). (SOLAS Reg. II-1/17.5)

17.1.3 Drainage systems in passenger ships

17.1.3.1 The bilge pumping system required by 2.3.1 (paragraph 2.1) shall be capable of operation under all practicable conditions after a casualty whether the ship is upright or listed. For this purpose wing suction shall generally be fitted except in narrow compartments at the end of the ship where one suction may be sufficient. In compartments of unusual form, additional suction may be required. Arrangements shall be made whereby water in the compartment may find its way to the suction pipes. Where, for particular compartments, the Administration is satisfied that the provision of drainage may be undesirable, it may allow such provision to be dispensed with if calculations made in accordance with the conditions laid down in regulations 7 and 8 (i.e. SOLAS Reg. II-1/7 and Reg. II-1/8) show that the survival capability of the ship will not be impaired. (SOLAS Reg. II-1/35-1.3.1)

17.1.3.2 At least three power pumps shall be fitted connected to the bilge main, one of which may be driven by the propulsion machinery. Where the bilge pump numeral is 30 or more, one additional independent power pump shall be provided.

The bilge pump numeral shall be calculated as follows:

when P_1 is greater than P : bilge pump numeral = $72 [(M+2P_1)/(V + P_1 - P)]$

in other cases: bilge pump numeral = $72 [(M+2P_1)/V]$

where:

L = the length of the ship (metres), as defined in 1.2.33 (regulation 2);

M = the volume of the machinery space (cubic metres), as defined in 1.2.40 (regulation 2), that is below the bulkhead deck; with the addition thereto of the volume of any permanent oil fuel bunkers which may be situated above the inner bottom and forward of, or abaft, the machinery space;

P = the whole volume of the passenger and crew spaces below the bulkhead deck (cubic metres), which are provided for the accommodation and use of passengers and crew, excluding baggage, store and provision rooms;

V = the whole volume of the ship below the bulkhead deck (cubic metres);

$P_1 = KN$,

where:

N = the number of passengers for which the ship is to be certified; and

$K = 0.056L$

However, where the value of KN is greater than the sum of P and the whole volume of the actual passenger spaces above the bulkhead deck, the figure to be taken as P_1 is that sum or two-thirds KN , whichever is the greater. (SOLAS Reg. II-1/35-1.3.2)

17.1.3.3 Where practicable, the power bilge pumps shall be placed in separate watertight compartments and so arranged or situated that these compartments will not be flooded by the same damage. If the main propulsion machinery, auxiliary machinery and boilers are in two or more watertight compartments, the pumps available for bilge service shall be distributed as far as is possible throughout these compartments. (SOLAS Reg. II-1/35-1.3.3)

17.1.3.4 (...) bilge pumps except those specifically serving the spaces forward of the collision bulkhead, (...) shall not be installed forward of the collision bulkhead. (SOLAS Reg. II-1/39)

17.1.3.5 On a ship of 91.5 m in length L and upwards or having a bilge pump numeral, calculated in accordance with 17.1.3.2 (paragraph 3.2), of 30 or more, the arrangements shall be such that at least one power bilge pump shall be available for use in all flooding conditions which the ship is required to withstand, and, for ships subject to the provisions of regulation II-1/1.1.1.1 (i.e. ships to which these *Rules* apply), in all flooding conditions derived from consideration of minor damages as specified in regulation 8 (i.e. SOLAS Reg. II-1/8) as follows:

- .1 one of the required bilge pumps shall be an emergency pump of a reliable submersible type having a source of power situated above the bulkhead deck; or
- .2 the bilge pumps and their sources of power shall be so distributed throughout the length of the ship that at least one pump in an undamaged compartment will be available. (SOLAS Reg. II-1/35-1.3.4)

17.1.3.6 With the exception of additional pumps which may be provided for peak compartments only, each required bilge pump shall be so arranged as to draw water from any space required to be drained by 2.3.1.1 (paragraph 2.1). (SOLAS Reg. II-1/35-1.3.5)

17.1.3.7 Each power bilge pump shall be capable of pumping water through the required main bilge pipe at a speed of not less than 2 m/s. Independent power bilge pumps situated in machinery spaces shall have direct suctions from these spaces, except that not more than two such suctions shall be required in any one space. Where two or more such suctions are provided, there shall be at least one on each side of the ship. The Administration may require independent power bilge pumps situated in other spaces to have separate direct suctions. Direct suctions shall be suitably arranged and those in a machinery space shall be of a diameter not less than that required for the bilge main. (SOLAS Reg. II-1/35-1.3.6)

17.1.3.8 In addition to the direct bilge suction or suctions required by 17.1.3.7 (paragraph 3.6), a direct suction from the main circulating pump leading to the drainage level of the machinery space and fitted with a non-return valve shall be provided in the machinery space. The diameter of this direct suction pipe shall be at least two thirds of the diameter of the pump inlet in the case of steamships, and of the same diameter as the pump inlet in the case of motorships. (SOLAS Reg. II-1/35-1.3.7.1)

17.1.3.9 Where in the opinion of the Administration the main circulating pump is not suitable for this purpose, a direct emergency bilge suction shall be led from the largest available independent power driven pump to the drainage level of the machinery space; the suction shall be of the same diameter as the main inlet of the pump used. The capacity of the pump so connected shall exceed that of a required bilge pump by an amount deemed satisfactory by the Administration. (SOLAS Reg. II-1/35-1.3.7.2)

17.1.3.10 The spindles of the sea inlet and direct suction valves shall extend well above the engine-room platform. (SOLAS Reg. II-1/35-1.3.7.3)

17.1.3.11 All bilge suction piping up to the connection to the pumps shall be independent of other piping. (SOLAS Reg. II-1/35-1.3.8)

17.1.3.12 The diameter d of the bilge main shall be calculated according to the following formula. However, the actual internal diameter of the bilge main may be rounded off to the nearest standard size acceptable to the Administration:

$$d = 25 + 1.68\sqrt{L(B + D)}$$

where:

- d is the internal diameter of the bilge main (millimetres);
- L, B are the length and the breadth of the ship (metres) as defined in 1.2.33 and 1.2.6 (regulation 2); and
- D is the moulded depth of the ship to the bulkhead deck (metres) provided that, in a ship having an enclosed cargo space on the bulkhead deck which is internally drained in accordance with the requirements of 2.4.3.15 (paragraph 2.6.2) and which extends for the full length of the ship, D shall be measured to the next deck above the bulkhead deck. Where the enclosed cargo spaces cover a lesser length, D shall be taken as the moulded depth to the bulkhead deck plus $l \cdot h / L$ where l and h are the aggregate length and height respectively of the enclosed cargo spaces (metres). The diameter of the bilge branch pipes shall meet the requirements of the Administration. (SOLAS Reg. II-1/35-1.3.9)

17.1.3.13 Provision shall be made to prevent the compartment served by any bilge suction pipe being flooded in the event of the pipe being severed or otherwise damaged by collision or grounding in any other compartment. For this purpose, where the pipe is at any part situated nearer the side of the ship than one fifth of the breadth of the ship (as defined in 1.2.6 (regulation 2) and measured at right angles to the centreline at the level of the deepest subdivision load line), or is in a duct keel, a non-return valve shall be fitted to the pipe in the compartment containing the open end. For ships subject to the provisions of regulation II-1/1.1.1.1 (i.e. ships to which these *Rules* apply), the deepest subdivision load line shall be taken as the deepest subdivision draught. (SOLAS Reg. II-1/35-1.3.10)

17.1.3.14 Distribution boxes, cocks and valves in connection with the bilge pumping system shall be so arranged that, in the event of flooding, one of the bilge pumps may be operative on any compartment; in addition, damage to a pump or its pipe connecting to the bilge main outboard of a line drawn at one fifth of the breadth of the ship shall not put the bilge system out of action. If there is only one system of pipes common to all the pumps, the necessary valves for controlling the bilge suction must be capable of being operated from above the bulkhead deck. Where in addition to the main bilge pumping system an emergency bilge pumping system is provided, it shall be independent of the main system and so arranged that a pump is capable of operating on any compartment under flooding condition as specified in 17.1.3.1 (paragraph 3.1); in that case only the valves necessary for the operation of the emergency system need be capable of being operated from above the bulkhead deck. (SOLAS Reg. II-1/35-1.3.11)

17.1.3.15 All cocks and valves referred to in 17.1.3.14 (paragraph 3.11) which can be operated from above the bulkhead deck shall have their controls at their place of operation clearly marked and shall be provided with means to indicate whether they are open or closed. (SOLAS Reg. II-1/35-1.3.12)

17.1.4 Air and sounding pipes in passenger ships

17.1.4.1 Open ends of air pipes led into superstructure shall be located at least 1 m above the waterline of the ship heeled to 15° or to the maximum angle of heel determined for the intermediate stages of flooding whichever is greater. Alternatively air pipes of tanks other than oil fuel and oil tanks may penetrate side walls of the superstructure subject to the requirements in 5.1.18.

17.1.5 Ventilation systems in passenger ships

17.1.5.1 General requirements

17.1.5.1.1 The ventilation systems for machinery spaces of category A, vehicle spaces, ro-ro spaces, galleys, special category spaces and cargo spaces shall, in general, be separated from each other and from the ventilation systems serving other spaces. However, the galley ventilation systems on (...) passenger ships carrying not more than 36 passengers need not be completely separated from other ventilation systems, but may be served by separate ducts from a ventilation unit serving other spaces. In such a case, an automatic fire damper shall be fitted in the galley ventilation duct near the ventilation unit. (SOLAS Reg. II-2/9.7.2.1)

17.1.5.1.2 Where it is necessary that a ventilation duct passes through a main vertical zone division, a fail-safe automatic closing fire damper shall be fitted adjacent to the division. The damper shall also be capable of being manually closed* from each side of the division. The operating position shall be readily accessible and be marked in red light-reflecting colour. The duct between the division and the damper shall be of steel or other equivalent material and, if necessary, insulated to comply with the requirements of 1.9.1 (paragraph 3.1). The damper shall be fitted on at least one side of the division with a visible indicator showing whether the damper is in the open position. (SOLAS Reg. II-2/9.4.1.1.9)

*** IMO interpretation**

Manual closing may be achieved by mechanical means of release or by remote operation of the fire damper by means of a fail-safe electrical switch or pneumatic release (spring-loaded, etc.) on both sides of the division. (MSC/Circ.1120)

17.1.5.1.3 Exhaust ducts from galley ranges in passenger ships carrying not more than 36 passengers – see *Part V*, 6.4.1.

17.1.5.1.4 Atriums shall be equipped with a smoke extraction system. The smoke extraction system shall be activated by the required smoke detection system and be capable of manual control. The fans shall be sized such that the entire volume within space can be exhausted in 10 min or less. (SOLAS, Reg. II-2/8.5)

Internal assembly stations shall be also equipped with a smoke extraction system.

IMO interpretation

The application of this regulation does not imply the arrangement of additional exhaust fans other than those normally dedicated to the space considered, if these latter fans are of sufficient size to meet the required capacity. (MSC/Circ.1120)

Note:

See also MSC/Circ.1034 *Guidelines for smoke control and ventilation systems for internal assembly stations and atriums on new passenger ships.*

17.1.5.1.5 It is recommended that escape routes be equipped with a smoke extraction system to maintain sufficiently smoke free atmosphere in case of fire. The system may be either independent or combined with other exhaust ventilation system or smoke management system.

Note:

See also MSC/Circ.1514 *Performance standard, functional requirements and system requirements for the assessment of smoke management systems.*

17.1.5.2 Passenger ships carrying more than 36 passengers

17.1.5.2.1 In passenger ships carrying more than 36 passengers, power ventilation, except machinery space and cargo space ventilation and any alternative system which may be required under 7.7.1 (regulation 8.2), shall be fitted with controls so grouped that all fans may be stopped from either of two separate positions which shall be situated as far apart as practicable. Fans serving power ventilation systems to cargo spaces shall be capable of being stopped from a safe position outside such spaces. (SOLAS, Reg. II-2/5.2.1.3)

IACS and IMO interpretation

The fan in a HVAC temperature control unit, or a circulation fan inside a cabinet/switchboard, is not considered to be a ventilation fan as addressed in 7.5.2 (Reg.II-2/5.2.1.2), 17.1.5.2.1 (Reg.II-2/5.2.1.3) and Reg.II-2/7.9.3 (concerns fire alarm signalling systems in passenger ships), if it is not capable of supplying outside air to the space when the power ventilation is shut down (e.g., small units intended for re-circulation of air within a cabin).

Therefore, such fans need not be capable of being stopped from an easily accessible position (or a safe position) outside the space being served when applying 7.5.2 (SOLAS Reg.II-2/5.2.1.2) or 17.1.5.2.1 (Reg.II-2/5.2.1.3), and need not be capable of being controlled from a continuously manned central control station for passenger ships carrying more than 36 passengers when applying SOLAS Reg.II-2/7.9.3 (concerns fire alarm signalling systems in passenger ships). (IACS UI SC148, MSC.1/Circ.1555)

17.1.5.2.2 In addition to the requirements in sections 7.2, 7.3 and 7.4 (7.1, 7.2 and 7.3), the ventilation system of a passenger ship carrying more than 36 passengers shall also meet the following requirements (i.e. 17.1.5.2.3 to 17.1.5.2.6). (SOLAS, Reg. II-2/9.7.4.1)

17.1.5.2.3 In general, the ventilation fans shall be so arranged that the ducts reaching the various spaces remain within a main vertical zone. (SOLAS, Reg. II-2/9.7.4.2)

17.1.5.2.4 Stairway enclosures shall be served by an independent ventilation fan and duct system (exhaust and supply) which shall not serve any other spaces in the ventilation systems. (SOLAS, Reg. II-2/9.7.4.3)

17.1.5.2.5 A duct, irrespective of its cross-section, serving more than one 'tween-deck accommodation space, service space or control station, shall be fitted, near the penetration of each deck of such spaces, with an automatic smoke damper that shall also be capable of being closed manually from the protected deck above the damper. Where a fan serves more than one 'tween-deck space through separate ducts within a main vertical zone, each dedicated to a single 'tween-deck space, each duct shall be provided with a manually operated smoke damper fitted close to the fan. (SOLAS, Reg. II-2/9.7.4.4)

17.1.5.2.6 Vertical ducts shall, if necessary, be insulated as required by tables 9.1 and 9.2 (see Part V, 11.1.2.2). Ducts shall be insulated as required for decks between the space they serve and the space being considered, as applicable. (SOLAS, Reg. II-2/9.7.4.5)

17.1.5.2.7 Exhaust ducts from galley ranges in passenger ships carrying more than 36 passengers – see Part V, 11.1.3.5.

17.1.5.2.8 Requirements for exhaust ducts from laundries and drying rooms – see Part V, 11.1.3.7.

17.1.6 Passenger ships having vehicle or special category spaces – additional marks: RO-RO/PASSENGER SHIP, RO-RO/PASSENGER SHIP (FERRY)

Passenger ships having vehicle or special category spaces shall also comply with: 17.3.1 and 17.3.2 (drainage of vehicle and special category spaces) as well as 17.3.3 (ventilation of vehicle and special category spaces) applicable to passenger ships.

17.1.7 Passenger ships engaged on domestic voyages – marks: Class A, Class B, Class C or Class D supplementing additional marks of passenger ships

Passenger ships engaged on domestic voyages within the EU Community waters, regardless of the flag they fly, shall comply with the safety requirements provided in *Publication 100/P – Safety requirements for sea-going passenger ships and high-speed passenger craft engaged in domestic voyages*.

17.1.8 Passenger ships subject to SOLAS regulations II-1/8-1, II-2/21 and II-2/22 (safe return to port, orderly evacuation and abandonment of the ship) – additional mark SRP

Passenger ships of 120 m in length or more, or having 3 or more main vertical zones shall also comply with the requirements specified in *Publication 90/P – Safe return to port and orderly evacuation and abandonment of the ship* concerning inter alia bilge and ballast systems, power-operated watertight doors, ventilation system, sanitary system and fuel oil systems.

17.2 Container ships – additional mark CONTAINER SHIP

17.2.1 Bilge systems for open top container holds shall be independent of the machinery space bilge system and located outside the machinery space.

17.2.2 For open top container ships, mechanical ventilation is required only for the lower part of the cargo hold (for which purpose ducting is required). The ventilation capacity shall be at least 2 air changes per hour based on the empty hold volume below weather deck.

17.3 Roll on-roll off ships – additional marks: RO-RO SHIP, RO-RO SHIP (FERRY), VEHICLE CARRIER

17.3.1 Drainage of vehicle, special category and ro-ro spaces

17.3.1.1 Scuppers shall not be led to machinery or other spaces where sources of ignition may be present. (SOLAS Reg. II-2/20.3.5)

17.3.1.2 (...) When fixed pressure water-spraying systems are fitted, in view of the serious loss of stability which could arise due to large quantities of water accumulating on the deck or decks during the operation of the fixed pressure water-spraying system, the following arrangements shall be provided:

.1 in passenger ships:

.1.1 in the spaces above the bulkhead deck, scuppers shall be fitted so as to ensure that such water is rapidly discharged directly overboard**, taking into account the guidelines developed by the Organization*;

* Refer to *Guidelines for the drainage of fire-fighting water from closed vehicle and ro-ro spaces and special category spaces for passenger and cargo ships* (MSC.1/Circ.1320) (see 17.3.2)

**** IMO interpretation**

For the sizing of scuppers and drainage pumps the capacity of both the water spraying system pumps and the water discharge from the required number of fire hose nozzles specified in Part V, 11.3.1.4.4 and 7.2.1 (regulations 10.2.1.5.1 and 19.3.1), as applicable, should be taken into account. (MSC/Circ.1120)

.1.2.1 in ro-ro passenger ships, discharge valves for scuppers, fitted with positive means of closing operable from a position above the bulkhead deck in accordance with the requirements of the *International Convention on Load Lines* in force, shall be kept open while the ships are at sea;

.1.2.2 (...)

.1.3 in the spaces below the bulkhead deck, the Administration may require pumping and drainage facilities to be provided additional to the requirements of regulation II-1/35-1 (see relevant paragraphs in 2.3, 2.4 and 17.1.3). In such case, the drainage system shall be sized to remove no less than 125% of the combined

capacity of both the water-spraying system pumps and the required number of fire hose nozzles, taking into account the guidelines developed by the Organization*. The drainage system valves shall be operable from outside the protected space at a position in the vicinity of the extinguishing system controls. Bilge wells shall be of sufficient holding capacity and shall be arranged at the side shell of the ship at a distance from each other of not more than 40 m in each watertight compartment;

* Refer to *Guidelines for the drainage of fire-fighting water from closed vehicle and ro-ro spaces and special category spaces for passenger and cargo ships* (MSC.1/Circ.1320). (see 17.3.2)

- .2** in cargo ships, the drainage and pumping arrangements shall be such as to prevent the build-up of free surfaces. In such case, the drainage system shall be sized to remove no less than 125% of the combined capacity of both the water-spraying system pumps and the required number of fire hose nozzles, taking into account the guidelines developed by the Organization*. The drainage system valves shall be operable from outside the protected space at a position in the vicinity of the extinguishing system controls. Bilge wells shall be of sufficient holding capacity and shall be arranged at the side shell of the ship at a distance from each other of not more than 40 m in each watertight compartment. If this is not possible, the adverse effect upon stability of the added weight and free surface of water shall be taken into account to the extent deemed necessary by the Administration in its approval of the stability information. (...) (SOLAS Reg. II-2/20.6.1.4)

* Refer to *Guidelines for the drainage of fire-fighting water from closed vehicle and ro-ro spaces and special category spaces for passenger and cargo ships* (MSC.1/Circ.1320). (see 17.3.2)

17.3.1.3 On all ships, for closed vehicles and ro-ro spaces and special category spaces, where fixed pressure water-spraying systems are fitted, means shall be provided to prevent the blockage of drainage arrangements, taking into account the guidelines developed by the Organization*. (...) (SOLAS Reg. II-2/20.6.1.5)

* Refer to *Guidelines for the drainage of fire-fighting water from closed vehicle and ro-ro spaces and special category spaces for passenger and cargo ships* (MSC.1/Circ.1320). (see 17.3.2)

17.3.2 Guidelines for the drainage of fire-fighting water from closed vehicle and ro-ro spaces and special category spaces for passenger and cargo ships

IMO MSC.1/Circ.1320

Note:

These Guidelines shall be considered as mandatory requirements. In justified cases PRS may consider deviations from these requirements.

17.3.2.1 GENERAL (1)

17.3.2.1.1 Purpose (1.1)

17.3.2.1.1.1 When fixed water-based fire-extinguishing systems are provided for the protection of closed vehicle and ro-ro spaces and special category spaces, adequate drainage facilities, as required by 17.3.1.2 (SOLAS regulation II-2/20.6.1.4), should be provided to prevent the accumulation of significant quantities of water on decks and the build-up of free surfaces. In addition, 17.3.1.3 (SOLAS regulation II-2/20.6.1.5) requires effective measures to be taken to ensure that floating debris does not cause blockage of the drains. **(1.1.1)**

17.3.2.1.1.2 When the direct overboard discharge provisions or the bilge system required by SOLAS II-1/35-1 requirements provided in 2.3.1, 2.3.2, 2.4.3 and 17.1.3 (SOLAS regulation II-

1/35-1) have a capacity sufficient for the additional flow from the fixed fire-extinguishing system and the required number of fire hoses, as determined by these Guidelines, additional drainage facilities are not required. (1.1.2)

17.3.2.1.1.3 Scuppers, freeing ports, discharges and bilge systems should be installed in accordance with SOLAS II-1/35-1 requirements provided in 2.3.1, 2.3.2, 2.4.3 and 17.1.3 (SOLAS regulation II-1/35-1) the relevant regulations of the *International Convention on Load Lines, 1966* (ICLL 66), and these Guidelines. (1.1.3)

17.3.2.1.1.4 In lieu of the above, the Administration, after having given consideration to the ship's arrangement and equipment, may accept other fixed installations if they afford equivalent protection. Any equivalent protection should demonstrate the capability to rapidly drain fire-fighting water from the affected decks and prevent the build-up of free surfaces under expected conditions of trim and list, for as long as the fire-extinguishing system is in operation. (1.1.4)

17.3.2.1.2 Application (1.2)

These Guidelines apply to the design of drainage systems in closed vehicle and ro-ro spaces and special category spaces required by 17.3.1.2 (SOLAS regulation II-2/20.6.1.4), and to the protection of drain openings required by 17.3.1.3 (SOLAS regulation II-2/20.6.1.5).

17.3.2.2 DEFINITIONS (2)

17.3.2.2.1 *Bilge wells* are recessed areas where water accumulates before entering the bilges. (2.1)

17.3.2.2.2 *Bulkhead deck* (...). In a cargo ship the freeboard deck may be taken as the bulkhead deck. (2.2)

17.3.2.2.3 *Drains*, as used in these Guidelines, refer to either scupper wells and scuppers, freeing ports, or bilge wells and drain pipes. (2.3)

17.3.2.2.4 *Freeing ports* are openings in the bulwarks on the open deck to allow water to drain directly overboard. (2.4)

17.3.2.2.5 *Scuppers* are a system of gravity deck drains and connected piping leading from scupper wells to the sideshell of the ship or to the bilge system. (2.5)

17.3.2.2.6 *Scupper wells* are recessed areas in the deck where water accumulates before entering the scuppers. (2.6)

17.3.2.3 DRAINAGE ARRANGEMENTS FOR PASSENGER SHIPS (3)

17.3.2.3.1 Arrangements above the bulkhead deck (3.1)

17.3.2.3.1.1 Above the bulkhead deck, except as provided in paragraph 1.1.2 above, an adequate number of properly-sized drains should be provided on each deck to ensure that the combined water flow from the fixed fire-extinguishing system and the required number of fire hoses can be rapidly discharged overboard or drain to a bilge system with a reservoir tank fitted with a high water level alarm. (3.1.1)

17.3.2.3.1.2 At least four drains should be located on each side of the protected space, uniformly distributed fore and aft. Freeing ports should not be installed in enclosed superstructures, as defined by regulation 3.10 of the ICLL 66. (3.1.2)

17.3.2.3.1.3 The drainage system on each side of the deck should have an aggregate capacity of not less than 125% of the maximum flow rate of the fixed fire-extinguishing system water pumps plus the flow from two fire hoses (four if required by SOLAS regulation II-2/19.3.1.2) (see *Part V*, 7.2.1.2 which requires 4 fire hoses for ships carrying dangerous goods). In case an automatic deep well or submersible pumping system is installed, the bilge pump capacity can be subtracted from the required drainage capacity. **(3.1.3)**

17.3.2.3.1.4 Minimum capacity of drains **(3.1.4)**

The minimum capacity of scuppers, freeing ports or a combination thereof should be determined in accordance with the provisions of paragraphs 17.3.2.3.1.4.1 (3.1.4.1) or 17.3.2.3.1.4.2 (3.1.4.2), respectively.

17.3.2.3.1.4.1 The minimum required area of scuppers and connected piping should be determined by the following formula:

$$A = \frac{Q}{0.5\sqrt{19.62(h - \sum h_i)}}$$

where:

- A is the total required sectional area of the drains on each side of the deck in m²;
- Q is the combined waterflow from the fixed fire-extinguishing system and the required number of fire hoses in m³/s;
- h is the elevation head difference between the bottom of the scupper well or suction level and the overboard discharge opening or highest approved load line in m; and
- $\sum h_i$ is the summation of head losses corresponding to scupper piping, fittings and valves in m.

In no case should the area of each individual drain be less than 0.0078 m² or 125 mm diameter piping. **(3.1.4.1)**

17.3.2.3.1.4.2 The minimum required area of freeing ports should be determined by the following formula:

$$A = \frac{Q}{0.5\sqrt{19.62(h_1 - h_2)}}$$

where:

- A is the total required sectional area of freeing ports on each side of the ship in m²;
- Q is the combined waterflow from the fixed fire-extinguishing system and the required number of fire hoses in m³/s; and
- $h_1 - h_2$ is the depth of water on the deck determined in accordance with 17.3.2.4.2 (paragraph 4.2).

If the cross-sectional area of freeing ports required by the ICLL 66 is equal to or greater than determined above, additional freeing ports are not required. **(3.1.4.2)**

17.3.2.3.2 Arrangements below the bulkhead deck **(3.2)**

17.3.2.3.2.1 Below the bulkhead deck, except as provided in 17.3.2.1.1.2 (paragraph 1.1.2 above), an efficient bilge pumping system should be provided to ensure that the combined waterflow from the fixed fire-extinguishing system and the required number of fire hoses can be rapidly collected and led to suitable arrangements for discharge overboard. The bilge system capacity should be not less than that required by 17.3.2.3.2.3 (paragraph 3.2.3). **(3.2.1)**

17.3.2.3.2.2 The bilge piping system should be arranged in accordance with SOLAS II-1/35-1 requirements provided in 2.3.1, 2.3.2, 2.4.3 and 17.1.3 3 (SOLAS chapter II-1). At least four bilge wells should be located on each side of the protected space, uniformly distributed fore and aft. **(3.2.2)**

17.3.2.3.2.3 The bilge pumping system on each side of the ship should have an aggregate capacity of not less than 125% of the maximum flow rate of the fixed fire-extinguishing system water pumps plus the flow from two fire hoses (four, if required by SOLAS regulation II-2/19.3.1.2) (see Part V, 7.2.1.2 which requires flow from 4 fire hoses for ships carrying dangerous goods). **(3.2.3)**

17.3.2.3.2.4 The required area of the main and branch bilge pipes for the protected space should be adequate to ensure a maximum waterflow of 2 m/s in each section of piping in accordance with 17.3.2.3.2.4.1 to 17.3.2.3.2.4.3 (paragraphs 3.2.4.1 to 3.2.4.3). **(3.2.4)**

17.3.2.3.2.4.1 If the drainage system is a bilge pumping system, the following three criteria should be satisfied:

$$\sum Q_{\text{bpump}} \geq 1.25Q$$

$$A_M \geq 0.625 Q \&$$

$$\sum A_B \geq 0.625 Q$$

where:

$\sum Q_{\text{bpump}}$ is the combined capacity of all power bilge pumps except the emergency bilge pump in m³/s;

Q is the combined waterflow from the fixed fire-extinguishing system and the required number of fire hoses in m³/s;

A_M is the sectional area of the main bilge pipe of the protected space in m²;

$\sum A_B$ is the total sectional area of branched bilge pipes for each side in m². **(3.2.4.1)**

17.3.2.3.2.4.2 If the drainage system is based on gravity drains leading to a reservoir tank, the minimum required area of drains and connected piping should be determined by 17.3.2.3.1.4 (paragraph 3.1.4). **(3.2.4.2)**

17.3.2.3.2.4.3 If the drainage system is a combined system, the relevant dimensioning for each part of the system should be determined using 17.3.2.3.2.4.1 and 17.3.2.3.2.4.2 (paragraphs 3.2.4.1 and 3.2.4.2). **(3.2.4.3)**

17.3.2.3.2.5 The required capacity of each bilge well should be at least 0.15 m³. **(3.2.5)**

17.3.2.3.2.6 If the system includes a reservoir tank, the tank should have adequate capacity for at least 20 min of operation at the required drainage capacity for the affected space. **(3.2.6)**

17.3.2.4 DRAINAGE ARRANGEMENTS FOR CARGO SHIPS (4)

17.3.2.4.1 In cargo ships, the drainage and pumping arrangements should be such as to prevent the build-up of free surfaces in accordance with 17.3.2.3.1 or 17.3.2.3.2 (paragraph 3.1 or 3.2, as appropriate). **(4.1)**

17.3.2.4.2 If the abovementioned pumping arrangement is not possible, the adverse effect upon stability of the added weight and free surface of water should be taken into account according to the *International Code on Intact Stability, 2008 (IS Code)*, chapter 3.

For that purpose, the depth of water ($h_1 - h_2$) on each deck should be calculated by multiplying the maximum flow rate of the installed fire-extinguishing system water pumps plus the flow from two fire hoses (four if required by SOLAS regulation II-2/19.3.1.2) (see *Part V*, 7.2.1.2 which requires flow from 4 fire hoses for ships carrying dangerous goods) by an operating time of 30 min. This volume of water should be divided by the area of the affected deck. (4.2)

17.3.2.5 PROTECTION OF DRAIN OPENINGS (5)

17.3.2.5.1 An easily removable grating, screen or other means should be installed over each drain opening in the protected spaces to prevent debris from blocking the drain. The total open area ratio of the grating to the attached drain pipe should be at least 6 to 1. The grating should be raised above the deck or installed at an angle to prevent large objects from blocking the drain. No dimension of the individual openings in the grating should be more than 25 mm. (5.1)

17.3.2.5.2 No grating or screen is required when a fixed mechanical system is provided to unblock the drainage system, or when other than a gravity drain system is provided with its own filter. (5.2)

17.3.2.5.3 A clearly visible sign or marking should be provided not less than 1,500 mm above each drain opening stating, "Drain opening – do not cover or obstruct". The marking should be in letters at least 50 mm in height. (5.3)

17.3.2.6 TESTING (6)

The drainage facilities on ro-ro passenger ships should be functionally tested before the ship enters service to verify that the capacity of the system is adequate. The drainage facilities on all ships should be periodically visually examined for blockage or other damage and should be flushed with fire hoses or similar means to verify that the system is functional, if obstructions are noted.

END OF IMO MSC.1/Circ.1320

17.3.3 Ventilation of vehicle, special category and ro-ro spaces

17.3.3.1 There shall be provided an effective power ventilation system* sufficient to give at least the following air changes:

.1 Passenger ships	
Special category spaces	10 air changes per hour
Closed ro-ro and vehicle spaces other than special category spaces for ships carrying more than 36 passengers	10 air changes per hour
Closed ro-ro and vehicle spaces other than special category spaces for ships carrying not more than 36 passengers	6 air changes per hour
.2 Cargo ships	6 air changes per hour

The Administration may require an increased number of air changes when vehicles are being loaded and unloaded. (SOLAS, Reg. II-2/20.3.1.1)

* IMO interpretation

Reference is made to MSC/Circ.729 Design guidelines and operational recommendations for ventilation systems in ro-ro cargo spaces. (MSC/Circ.1120)

Note:

MSC/Circ.729 has been superseded by MSC.1/Circ.1515 *Revised design guidelines and operational recommendations for ventilation systems in ro-ro cargo spaces*.

17.3.3.2 In passenger ships, the power ventilation system shall be separate from other ventilation systems. The power ventilation system shall be operated to give at least the number of air changes required in 17.3.3.1 (paragraph 3.1.1) at all times when vehicles are in such spaces, except where an air quality control system in accordance with 17.3.3.5 (paragraph 3.1.2.4) is provided. Ventilation ducts serving such cargo spaces capable of being effectively sealed shall be separated for each such space. The system shall be capable of being controlled from a position outside such spaces. (SOLAS, Reg. II-2/20.3.1.2.1)

The means of remote control should be designed with fireproof components (using steel piping or equivalent and fireproof cables), operated from a safe location, which shall not be cut off by a fire in any ro-ro space or on weather decks and provided with indication (open/closed) in that position.

17.3.3.3 In cargo ships, the ventilation fans shall normally be run continuously and give at least the number of air changes required in 17.3.3.1 (paragraph 3.1.1) whenever vehicles are on board, except where an air quality control system in accordance with 17.3.3.5 (paragraph 3.1.2.4) is provided. Where this is impracticable, they shall be operated for a limited period daily as weather permits and in any case for a reasonable period prior to discharge, after which period the ro-ro or vehicle space shall be proved gas-free. One or more portable combustible gas detecting instruments shall be carried for this purpose. The system shall be entirely separate from other ventilation systems. Ventilation ducts serving ro-ro or vehicle spaces shall be capable of being effectively sealed for each cargo space. The system shall be capable of being controlled from a position outside such spaces. (SOLAS, Reg. II-2/20.3.1.2.2)

17.3.3.4 The ventilation system shall be such as to prevent air stratification and the formation of air pockets. (SOLAS, Reg. II-2/20.3.1.2.3)

17.3.3.5 For all ships, where an air quality control system is provided based on the guidelines developed by the Organization, * the ventilation system may be operated at a decreased number of air changes and/or a decreased amount of ventilation. This relaxation does not apply to spaces to which at least ten air changes per hour is required by paragraph 3.2.2 of this regulation (vehicle and ro-ro spaces located below the bulkhead deck where electrical equipment, which is not of non-sparking construction but is of a type so enclosed and protected as to prevent the escape of sparks, has been installed above a height of 450 mm from the deck or from a platform for vehicles) and spaces subject to regulations 7.2.4.1 of Part V (19.3.4.1 – spaces for the carriage of dangerous goods) and 17.3.3.9 (20-1 – spaces of vehicle carriers carrying as cargo motor vehicles with compressed hydrogen or natural gas in their tanks for their own propulsion). (SOLAS, Reg. II-2/20.3.1.2.4)

* Refer to the *Revised design guidelines and operational recommendations for ventilation systems in ro-ro cargo spaces* (MSC.1/Circ.1515).

17.3.3.6 Means shall be provided on the navigation bridge to indicate any loss of the required ventilating capacity. (SOLAS, Reg. II-2/20.3.1.3)

IACS and IMO interpretation

The requirement to indicate any loss of ventilating capacity is considered complied with by an alarm on the bridge, initiated by fall-out of starter relay of fan motor. (IACS UI SC75, MSC/Circ.1120)

17.3.3.7 Arrangements shall be provided to permit a rapid shutdown and effective closure of the ventilation system from outside of the space in case of fire, taking into account the weather and sea conditions. (SOLAS, Reg. II-2/20.3.1.4.1)

IACS and IMO interpretation

Access routes to the controls for closure of the ventilation system "permit a rapid shutdown" and adequately "take into account the weather and sea conditions" if the routes:

- .1 are clearly marked and at least 600 mm clear width;*
- .2 are provided with a single handrail or wire rope lifeline not less than 10 mm in diameter, supported by stanchions not more than 10 m apart in way of any route which involves traversing a deck exposed to weather; and*
- .3 are fitted with appropriate means of access (such as ladders or steps) to the closing devices of ventilators located in high positions (i.e. 1.8 m and above).*

Alternatively, remote closing and position indicator arrangements from the bridge or a fire control station for those ventilator closures is acceptable. (IACS UI SC243, MSC.1/Circ.1434)

Note:

Shutdown arrangements for periodically unattended machinery spaces – see 18.3.4.

17.3.3.8 Ventilation ducts, including dampers, within a common horizontal zone shall be made of steel. In passenger ships, ventilation ducts that pass through other horizontal zones or machinery spaces shall be "A-60" class steel ducts constructed in accordance with 7.3.4.1.1 and 7.3.4.1.2 (regulations 9.7.2.4.1.1 and 9.7.2.4.1.2). (SOLAS, Reg. II-2/20.3.1.4.2)

IMO interpretation

Ventilation ducts should not pass through machinery spaces of category A unless fire insulated to A-60 standard. (MSC/Circ.1120)

17.3.3.9 In the case of vehicle carriers, spaces intended for the carriage of motor vehicles, as cargo, with compresses natural gas or compressed hydrogen in their tanks for their own propulsion, the following additional requirements apply:

- .1** The fans shall be such as to avoid the possibility of ignition of methane and air mixtures (see *Part VII*, 5.3.2). Suitable wire mesh guards (the mesh size not exceeding 13 x 13 mm) shall be fitted over inlet and outlet ventilation openings. (SOLAS, Reg. II-2/20-1.3.2.2)
- .2** The fans shall be designed such as to avoid the possibility of ignition of hydrogen and air mixtures (see *Part VII*, 5.3.2). Suitable wire mesh guards (the mesh size not exceeding 13 x 13 mm) shall be fitted over inlet and outlet ventilation openings. (SOLAS, Reg. II-2/20-1.4.2.2)
- .3** Electric motors of the fans shall comply with the requirements specified in *Part VIII*, 22.2.1. It is recommended that the electric motors be not situated in the stream of discharged gases.

17.4 Bulk carriers and combination carriers – additional marks: BULK CARRIER, SELF-UNLOADING BULK CARRIER, ORE CARRIER, CEMENT CARRIER, ORE CARRIER/CRUDE OIL TANKER, BULK CARRIER/ORE CARRIER/CRUDE OIL TANKER

Note:

Combination carriers receiving in their symbol of class additional mark **CRUDE OIL TANKER** shall also comply with the relevant requirements of *Section 17.6*.

17.4.1 Hold, ballast and dry space water ingress alarms

Bulk carriers shall be fitted with water level detectors in accordance with *Part VIII*, 22.8.1.

17.4.2 Availability of pumping systems

17.4.2.1 On bulk carriers, the means for draining and pumping ballast tanks forward of the collision bulkhead and bilges of dry spaces any part of which extends forward of the foremost cargo hold shall be capable of being brought into operation from a readily accessible enclosed space, the location of which is accessible from the navigation bridge or propulsion machinery control position without traversing exposed freeboard or superstructure decks. Where pipes serving such tanks or bilges pierce the collision bulkhead, valve operation by means of remotely operated actuators may be accepted, as an alternative to the valve control specified in 1.8.2.2 (regulation II-1/12), provided that the location of such valve controls complies with this regulation. (SOLAS, Reg. XII/13.1)

IACS and IMO interpretation

1. *Where the piping arrangements for dewatering closed dry spaces are connected to the piping arrangements for the drainage of water ballast tanks, two non-return valves are to be provided to prevent the ingress of water into dry spaces from those intended for the carriage of water ballast. One of these non-return valves is to be fitted with shut-off isolation arrangement. The non-return valves are to be located in readily accessible positions. The shut-off isolation arrangement is to be capable of being controlled from the navigation bridge, the propulsion machinery control position or enclosed space which is readily accessible from the navigation bridge or the propulsion machinery control position without travelling exposed freeboard or superstructure decks. In this context, a position which is accessible via an under deck passage, a pipe trunk or other similar means of access is not to be taken as being in the "readily accessible enclosed space".*
2. *Under 17.4.1 (i.e. this Regulation 13.1 of SOLAS Chapter XII as amended by IMO resolutions up to MSC.170(79) (hereinafter the same)):*
 - 2.1 *the valve specified under 1.8.2.2 (Regulation 12.5.1 of SOLAS Chapter II-1 as amended by IMO resolutions up to MSC.436(99) (hereinafter the same)) is to be capable of being controlled from the navigation bridge, the propulsion machinery control position or enclosed space which is readily accessible from the navigation bridge or the propulsion machinery control position without travelling exposed freeboard or superstructure decks. In this context, a position which is accessible via an under deck passage, a pipe trunk or other similar means of access is not to be taken as being in the "readily accessible enclosed space";*
 - 2.2 *the valve is not to move from the demanded position in the case of failure of the control system power or actuator power;*
 - 2.3 *positive indication is to be provided at the remote control station to show that the valve is fully open or closed;*
 - 2.4 *local hand powered valve operation from above the freeboard deck as specified in 1.8.2.2 (Regulation 12.5.1 of SOLAS Chapter II-1) is required. An acceptable alternative to such arrangement may be remotely operated actuators as specified in 17.4.1 (Regulation 13.1 of SOLAS Chapter XII) on the condition that all provisions in 17.4.1 (13.1) are met.*
3. *The dewatering arrangements are to be such that any accumulated water can be drained directly by a pump or eductor.*
4. *The dewatering arrangements are to be such that when they are in operation, other systems essential for the safety of the ship including fire-fighting and bilge systems remain available and ready for immediate use. The systems for normal operation of electric power supplies, propulsion and steering are not to be affected by the operation of the dewatering systems. It must also be possible to immediately start fire pumps and have a ready available supply of fire-fighting water and to be able to configure and use bilge system for any compartment when the dewatering system is in operation.*
5. *Bilge wells are to be provided with gratings or strainers that will prevent blockage of the dewatering system with debris.*
6. *The enclosures of electrical equipment for the dewatering system installed in any of the forward dry spaces are to provide protection to IPX8 standard as defined in IEC 60529:1989/AMD2:2013/COR1:2019 for a water head equal to the height of the space in which the electrical equipment is installed for a time duration of at least 24 hours. (IACS UI SC179, MSC.1/Circ.1572/Rev.1 section 10)*

17.4.3 Draining and pumping forward spaces in bulk carriers

17.4.3.1 (...) bulk carriers constructed generally with single deck, top-side tanks and hopper side tanks in cargo spaces intended primarily to carry dry cargo in bulk (...), shall have dewatering capacity for the forward spaces as specified below:

The dewatering system for ballast tanks located forward of the collision bulkhead and for bilges of dry spaces any part of which extends forward of the foremost cargo hold^[1] is to be designed to remove water from the forward spaces at a rate of not less than $320A$ m³/h, where A is the cross-sectional area in m² of the largest air pipe or ventilator pipe connected from the exposed deck to a closed forward space that is required to be dewatered by these arrangements.

^[1] Reference is made to SOLAS regulation XII/13 and Unified Interpretation SC 179 "Dewatering of forward spaces of bulk carriers". (IACS UR M65)

17.5 General cargo ships – additional marks: DRY CARGO SHIP, CEMENT CARRIER

17.5.1 General cargo ships having a length (L) of less than 80 m, and a single cargo hold below the freeboard deck or cargo holds below the freeboard deck which are not separated by at least one bulkhead made watertight up to that deck, shall be fitted in such space or spaces with water level detectors in accordance with *Part VIII*, 7.9.

17.6 Oil tankers – additional marks: CRUDE OIL TANKER, PRODUCT CARRIER A, PRODUCT CARRIER B

17.6.1 Bilge system

17.6.1.1 For the drainage of fore compartments, provision shall be made for a separate pump or ejector, which may be also used for draining and filling the tanks intended for water ballast only.

17.6.1.2 The cargo pump-rooms shall be drained by separate pumps or ejectors located in these rooms. Stripping pump discharging to the slop tank may be used for this purpose, provided that shut-off non-return valves are fitted on the branch bilge suctions and shut-off valve is fitted on the piping connecting the bilge suction valve box to the stripping pump.

17.6.1.3 Where bilge pumps are intended for the drainage of machinery spaces only, the cross-sectional area of the bilge main shall not be less than two times the cross-sectional area of the branch pipe for the space – see 2.3.2.7.

17.6.1.4 A system providing for the discharge of oily bilge water from machinery space to a slop tank or to a designated cargo tank serving for such purpose may be accepted, provided that the system is so constructed as to preclude the cargo and its vapours from entering the machinery space.

17.6.2 Ballast and cargo oil systems

17.6.2.1 Every crude oil tanker of 20 000 tonnes deadweight and above and every product carrier of 30 000 tonnes deadweight and above* (...), shall be provided with segregated ballast tanks (...). (MARPOL, Reg. I/18.1)

*** IMO interpretation**

When an oil tanker is used as a floating facility to receive dirty ballast discharged from oil tankers, such a tanker is not required to comply with the provisions of 17.6.2.1 (regulations 18), (...). (MEPC52 Annex 3)

17.6.2.2 Ballast tanks adjacent to cargo and/or slop tanks shall be drained by means of separate pumps.

17.6.2.3 Ballast pumps (located in pump-rooms of oil tankers of 5,000 tonnes deadweight and above) shall be provided with suitable arrangements to ensure efficient suction from double bottom tanks. (MARPOL, Reg. I/22.4)

IACS interpretation

1. The term “pump-room” means a cargo pump room. Ballast piping is permitted to be located within the pump-room double bottom provided any damage to that piping does not render the ship’s pumps located in the “pump room” ineffective.
2. The double bottom protecting the “pump-room” can be a void tank, a ballast tank or, unless prohibited by other regulations, a fuel oil tank.

(...) (IACS UI MPC85)

17.6.2.4 Inlets and overboard discharges of clean ballast tanks shall not be connected to bottom valves and discharge boxes serving cargo tanks intended for ballast purposes in heavy weather conditions.

17.6.2.5 Ballast piping and other piping such as sounding and vent piping to ballast tanks shall not pass through cargo tanks. Cargo piping and similar piping to cargo tanks shall not pass through ballast tanks. Exemptions to this requirement may be granted for short lengths of piping, provided that they are completely welded or equivalent. (MARPOL, Reg. I/19.3.6)

IMO interpretation

When an oil tanker is used as a floating facility to receive dirty ballast discharged from oil tankers, such a tanker is not required to comply with the provisions of 17.6.2.5 (regulations (...) 19 (...)). (MEPC52 Annex 3)

17.6.2.6 Reinforced thickness of ballast and cargo oil piping

IACS UR F15

17.6.2.6.1 Ballast piping passing through cargo tanks and cargo oil pipes passing through segregated ballast tanks, as permitted by 17.6.2.5 (Regulation 19.3.6 of MARPOL Annex I), are to comply with the following requirements. **(F15.1)**

17.6.2.6.1.1 The pipes are to be of heavy gauge steel of minimum wall thickness according to the table hereunder with welded or heavy flanged joints the number of which is to be kept to a minimum.

Expansion bends only (not glands) are permitted in these lines within cargo tanks for serving the ballast tanks and within the ballast tanks for serving the cargo tanks. **(F15.1.1)**

Nominal diameter (mm)	Minimum wall thickness (mm)
50	6.3
100	8.6
125	9.5
150	11.0
200 and above	12.5

17.6.2.6.2 The thicknesses shown in the above table refer to carbon steel. **(F15.2)**

17.6.2.6.3 Connection between cargo piping and ballast piping referred to above is not permitted except for emergency discharge as specified in the Unified Interpretation to Regulation 1.18 of MARPOL Annex I (text of the Unified Interpretation follows below in italics).

Nevertheless, provision may be made for emergency discharge of the segregated ballast by means of a connection to a cargo pump through a portable spool piece. In this case non-return valves should be fitted on the segregated ballast connections to prevent the passage of oil to the ballast tanks. The portable spool piece should be mounted in a conspicuous position in the pump room and a permanent notice restricting its use should be prominently displayed adjacent to it.

Shut-off valves shall be provided to shut off the cargo and ballast lines before the spool piece is removed. **(F15.3)**

17.6.2.6.4 The ballast pump is to be located in the cargo pump room, or a similar space within the cargo area not containing any source of ignition. **(F15.4)**

END OF IACS UR F15

17.6.2.7 For integrated cargo and ballast systems on tankers (i.e. hydraulic and/or electric system used to drive both cargo and ballast pumps) – see *Part VIII*, 22.5.9.

17.6.2.8 Forepeak ballast system on oil tankers

IACS UR F44

The forepeak tank can be ballasted with the system serving other ballast tanks within the cargo area, provided:

- The forepeak tank is considered as a hazardous area;
- The vent pipe openings are located on open deck at an appropriate distance from sources of ignition. In this respect, the hazardous zones distances are to be defined in accordance to IEC 60092-502: Electrical installations in ships – Tankers – Special features;
- Means are provided, on the open deck, to allow measurement of flammable gas concentrations within the forepeak tank by a suitable portable instrument;
- The sounding arrangement to the forepeak tank is direct from open deck;
- The access to the forepeak tank is direct from open deck. Alternatively, indirect access from the open deck to the forepeak tank through an enclosed space may be accepted provided that:
 1. In case the enclosed space is separated from the cargo tanks by cofferdams, the access is through a gas tight bolted manhole located in the enclosed space and a warning sign is to be provided at the manhole stating that the forepeak tank may only be opened after:
 - it has been proven to be gas free; or
 - any electrical equipment which is not certified safe in the enclosed space is isolated.
 2. In case the enclosed space has a common boundary with the cargo tanks and is therefore a hazardous area, the enclosed space can be well ventilated.

In respect to all paragraphs of this unified requirement, the hazardous area classification is to be defined in accordance to IEC 60092-502: Electrical installations in ships – Tankers – Special features.

END OF IACS UR F44

17.6.2.9 Oil shall not be carried in any space extending forward of a collision bulkhead located in accordance with regulation II-1/11 of the International Convention for the Safety of Life at Sea, 1974, as amended.* An oil tanker that is not required to have a collision bulkhead in accordance with that regulation shall not carry oil in any space extending forward of the transverse plane perpendicular to the centreline that is located as if it were a collision bulkhead located in accordance with that regulation. (MARPOL, Reg. I/19.7)

* Refer to 2006 (Chapters II-1, II-2, III and XII and appendix) amendments (resolution MSC.216(82)).

IMO interpretation

When an oil tanker is used as a floating facility to receive dirty ballast discharged from oil tankers, such a tanker is not required to comply with the provisions of 17.6.2.9 (regulations (...) 19 (...)). (MEPC52 Annex 3)

17.6.2.10 Cargo and stripping pumps shall not be used for other purposes than for serving the cargo tanks, except for the case mentioned in 17.6.2.6.3. The pumps shall not have connections with spaces other than the cargo spaces. Cargo and stripping pumps shall be located in a separate pump room.

17.6.2.11 Means shall be provided for stopping each cargo and stripping pump from the top platform of the pump room situated at the level of the main deck. Where a main cargo control station is provided, it is sufficient that stopping arrangements of the pumps be installed at the station.

17.6.2.12 Motors intended for the drive of pumps in cargo pump room shall be installed in spaces provided with mechanical ventilation system and having no exits to the cargo pump rooms. Steam engines of working temperature not exceeding 220°C, as well as hydraulic motors may be installed in the pump rooms.

17.6.2.13 Where drive shafts pass through pump room bulkhead or deck plating, gastight glands are to be fitted. The glands are to be efficiently lubricated from outside the pumproom. The seal parts of the glands are to be of material that will not initiate sparks. The glands are to be constructed and fitted in accordance with the relative rules for fittings attached to watertight bulkheads, and if a bellows piece is incorporated in the design, it should be pressure tested before fitting. (IACS UR F13)

17.6.2.14 The pumps, their drives, valves and fittings shall be so constructed as to preclude, to the maximum extent, the possibility of sparks being emitted. Electric drives of cargo pumps shall comply with the requirements specified in *Part VIII*, 5.7.

17.6.2.15 Pressure gauges of the cargo discharge and stripping lines shall be installed at the pumps and on the top platform of the pump room or in the main cargo control station.

17.6.2.16 Every oil tanker (...), required to be provided with segregated ballast tanks (see 17.6.2.1) or fitted with a crude oil washing system (see 17.6.5), shall comply with the following requirements:

- .1 it shall be equipped with oil piping so designed and installed that oil retention in the lines is minimized; and
- .2 means shall be provided to drain all cargo pumps and all oil lines at the completion of cargo discharge, where necessary by connection to a stripping device. The line and pump draining shall be capable of being discharged both ashore and to a cargo tank or a slop tank. For discharge ashore a special small diameter line shall be provided and shall be connected outboard of the ship's manifold valves. (MARPOL, Reg. I/30.4)

IMO interpretation

50.1 For the purpose of application of 17.6.2.16.2 (regulation 30.4.2), the cross sectional area of the small diameter line should not exceed:

- .1 10% of that of a main cargo discharge line for oil tankers delivered after 1 June 1982, (...) or
- .2 (...).

50.3 The phrase "connected outboard of" with respect to the small diameter line for discharge ashore should be interpreted to mean a connection on the downstream side of the tanker's deck manifold valves, both port and starboard, when the cargo is being discharged.

This arrangement would permit drainage back from the tanker's cargo lines to be pumped ashore with the tanker's manifold valves closed through the same connections as for main cargo lines (see the sketch shown in appendix 3 – below).

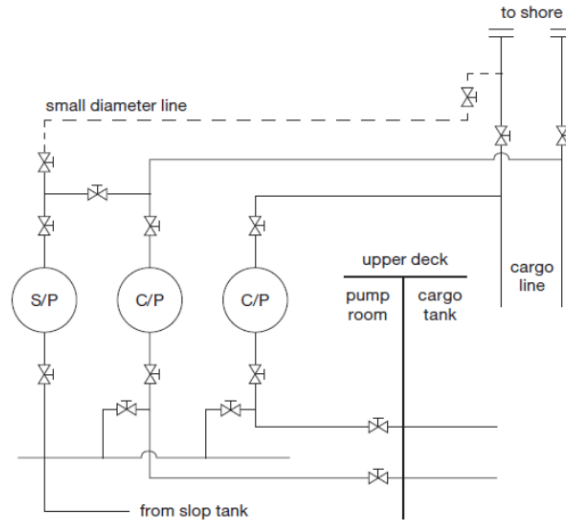

(MEPC52 Annex 3)

17.6.2.17 Every oil tanker (...), which has installed a sea chest that is permanently connected to the cargo pipeline system, shall be equipped with both a sea chest valve and an inboard isolation valve. In addition to these valves, the sea chest shall be capable of isolation from the cargo piping system whilst the tanker is loading, transporting, or discharging cargo by use of a positive means that is to the satisfaction of the Administration. Such a positive means is a facility that is installed in the pipeline system in order to prevent, under all circumstances, the section of pipeline between the sea chest valve and the inboard valve being filled with cargo. (MARPOL, Reg. I/30.7)

17.6.2.18 In the case of remote control of cargo system all valves located between the cargo lines and pumps apart from means of remote control shall be fitted with means of manual operation.

17.6.2.19 The pipelines on deck and in cargo tanks shall be properly fixed and provided with expansion joints.

17.6.2.20 All portions of pipes connected by means of flanges shall be so connected as to ensure electrical conductivity. The pipelines shall be electrically bonded to the hull – see Part VIII, 2.5.6.

In order to avoid the generation of static electricity when cargo is loaded direct into tanks, the loading pipes are to be led as low as practicable in the tank. (IACS UR F22)

17.6.2.21 The means used for the control of valves located inside the cargo tanks and cofferdams shall fulfil the following requirements:

- strips or bushes securing such means shall be made of such materials which preclude the possibility of sparks being emitted,
- the means shall be led to the open deck through gastight glands of a construction that allows replacement of packing from the deck,
- the means shall be provided with position indicators (valve open/valve closed),

- construction of the means shall preclude formation of any traps where the cargo residues might collect.

17.6.2.22 Shore connections intended for the attachment of shore hoses shall be made of materials precluding the possibility of sparks being emitted. The connections shall be fitted with cut-off valves and blank flanges. Blank flanges are not required when patent couplings are applied.

17.6.2.23 Drip pans for collecting cargo residues in cargo lines and hoses shall be provided in the area of pipe and hose connections under the manifold area. Cargo hoses and tank washing hoses shall have electrical continuity over their entire lengths including couplings and flanges (except shore connections) and shall be earthed for removal of electrostatic charges. (SOLAS, Reg. II-2/4.5.9)

Cargo spray shields shall be provided at the hose connections.

17.6.2.24 Where a cargo hose connection is arranged outside the cargo tank area (i.e. in case of bow and stern loading arrangements), the pipe leading to such connections is to be provided with means of segregation such as a spectacle flange, removable spool piece or equivalent* located within the cargo area. The space within 3 m of the manifold is to be considered as a dangerous area with regard to electrical or incensive equipment. (IACS UR F16)

* See MSC/Circ. 474.

17.6.2.25 The pipes of stern and bow loading and unloading arrangements shall be permanently installed. At the loading/unloading stations portable adaptors and couplings may be used.

17.6.2.26 Stern and bow loading and unloading lines shall not be led through accommodation and service spaces as well as machinery spaces located within the accommodation spaces or control stations.

17.6.2.27 Stern and bow loading and unloading lines outside the cargo area shall be connected by welding. Flange connections are acceptable only at valves, expansion joints and at the loading/unloading stations. Expansion joints may be installed in such lines only when indispensable. The lines shall be clearly marked.

17.6.2.28 Shore connections of stern and bow loading/unloading stations shall meet the requirements 17.6.2.23; however, the drip pans and cargo spray shields are not required where the connections are located outboard.

17.6.2.29 In ships provided with bow loading arrangements and equipped for single point offshore mooring a quick release system shall be provided for cargo hoses. The design and location of such arrangements are subject to PRS acceptance in each particular case.

17.6.2.30 In combination carriers only:

(...)

- .4 Where cargo wing tanks are provided, cargo oil lines below deck shall be installed inside these tanks. However, the Administration may permit cargo oil lines to be placed in special ducts provided there are capable of being adequately cleaned and ventilated to the satisfaction of the Administration. Where cargo wing tanks are not provided, cargo oil lines below deck shall be placed in special ducts. (SOLAS, Reg. II-2/4.5.1.4)

17.6.3 Retention of oil on board

Note:

In accordance with MARPOL Reg. I/3 the flag Administration may waive the requirements concerning slop tank arrangements (Reg. I/29 i.e. 17.6.3.1 to 17.6.3.6) for any oil tanker engaged exclusively on voyages of restricted duration and area/range of navigation, provided that all oily mixtures are retained on board for subsequent discharge to reception facilities and such facilities are available and adequate.

17.6.3.1 (...) oil tankers of 150 gross tonnage and above shall be provided with slop tank arrangements in accordance with the requirements of 17.6.3.2 to 17.6.3.4 (paragraphs 2.1 to 2.3 of this regulation). (...) (MARPOL, Reg. I/29.1)

17.6.3.2 Adequate means shall be provided for cleaning the cargo tanks and transferring the dirty ballast residue and tank washings from the cargo tanks into a slop tank approved by the Administration. (MARPOL, Reg. I/29.2.1)

17.6.3.3 In this system arrangements shall be provided to transfer the oily waste into a slop tank or combination of slop tanks (...). (MARPOL, Reg. I/29.2.2)

17.6.3.4 The arrangements of the slop tank or combination of slop tanks shall have a capacity necessary to retain the slop generated by tank washings, oil residues and dirty ballast residues. The total capacity of the slop tank or tanks shall not be less than 3% of the oil carrying capacity of the ship, except that the Administration may accept:

- .1 2% for such oil tankers where the tank washing arrangement are such that once the slop tank or tanks are charged with washing water, this water is sufficient for tank washing and, where applicable, for providing the driving fluid for eductors, without the introduction of additional water into the system;
- .2 2% where segregated ballast tanks or dedicated clean ballast tanks are provided in accordance with 17.6.2.1 (regulation 18 of this Annex), or where a cargo tank cleaning system using crude oil washing is fitted in accordance with 17.6.5 (regulation 33 of this Annex). This capacity may be further reduced to 1.5% for such oil tankers where the tank washing arrangements are such that once the slop tank or tanks are charged with washing water, this water is sufficient for tank washing and, where applicable, for providing the driving fluid for eductors, without the introduction of additional water into the system; and
- .3 1% for combination carriers where oil cargo is only carried in tanks with smooth walls. This capacity may be further reduced to 0.8% where the tank washing arrangements are such that once the slop tank or tanks are charged with washing water, this water is sufficient for tank washing and, where applicable, for providing the driving fluid for eductors, without the introduction of additional water into the system. (MARPOL, Reg. I/29.2.3)

17.6.3.5 Slop tanks shall be so designed particularly in respect of the position of inlets, outlets, baffles or weirs where fitted, so as to avoid excessive turbulence and entrainment of oil or emulsion with the water. (MARPOL, Reg. I/29.2.4)

17.6.3.6 Oil tankers of 70 000 tonnes deadweight and above (...), shall be provided with at least two slop tanks. (MARPOL, Reg. I/29.3)

17.6.3.7 In combination carriers only:

- .1 The slop tanks shall be surrounded by cofferdams except where the boundaries of the slop tanks, where slop may be carried on dry cargo voyages, are part of the hull, main cargo deck, cargo pump-room bulkhead or oil fuel bunker tank. (...) Means shall be provided for filling the cofferdams with water and for draining them. (...)

- .2** Means shall be provided for isolating the piping connecting the pump-room with the slop tanks (...). The means of isolation shall consist of a valve followed by a spectacle flange or a spool piece with appropriate blank flanges. This arrangement shall be located adjacent to the slop tanks, but where this is unreasonable or impracticable, it may be located within the pump-room directly after the piping penetrates the bulkhead. A separate permanently installed pumping and piping arrangement incorporating a manifold, provided with a shut-off valve and a blank flange, shall be provided for discharging the contents of the slop tanks directly to the open deck for disposal to shore reception facilities when the ship is in the dry cargo mode. When the transfer system is used for slop transfer in the dry cargo mode, it shall have no connection to other systems. Separation from other systems by means of removal of spool pieces may be accepted;
- .3** (...) (SOLAS, Reg. II-2/4.5.1.4)

17.6.4 Control of oil discharge

Note:

In accordance with MARPOL Reg. I/3 the flag Administration may waive the requirements concerning oil discharge monitoring and control system (Reg. I/31 i.e. 17.6.4.5 to 17.6.4.8) and oil/water interface detectors (Reg. I/32 i.e. 17.6.4.9) for any oil tanker engaged exclusively on voyages of restricted duration and area/range of navigation, provided that all oily mixtures are retained on board for subsequent discharge to reception facilities and such facilities are available and adequate.

17.6.4.1 In every oil tanker, a discharge manifold for connection to reception facilities for the discharge of dirty ballast water or oil-contaminated water shall be located on the open deck on both sides of the ship. (MARPOL, Reg. I/30.1)

17.6.4.2 In every oil tanker of 150 gross tonnage and above, pipelines for the discharge to the sea of ballast water or oil contaminated water from cargo tank areas (...) shall be led to the open deck or to the ship's side above the waterline in the deepest ballast condition. Different piping arrangements to permit operation in the manner permitted in 17.6.4.4 (subparagraphs 6.1 to 6.5 of this regulation) may be accepted. (MARPOL, Reg. I/30.2)

IMO interpretation

49.1.1 Under 17.6.4.2 (regulation 30.2) lines for discharge to the sea above the waterline must be led either:

- .1** to a ship's discharge outlet located above the waterline in the deepest ballast condition; or
- .2** to a midship discharge manifold or, where fitted, a stern or bow loading/discharge facility above the upper deck.

49.1.2 The ship's side discharge outlet referred to in 49.1.1.1 should be so located that its lower edge will not be submerged when the ship carries the maximum quantity of ballast during its ballast voyages, having regard to the type and trade of the ship. The discharge outlet located above the waterline in the following ballast condition will be accepted as complying with this requirement:

- .1** on oil tankers not provided with SBT or CBT, the ballast condition when the ship carries both normal departure ballast and normal clean ballast simultaneously; and
- .2** on oil tankers provided with SBT or CBT, the ballast condition when the ship carries ballast water in segregated or dedicated clean ballast tanks, together with additional ballast in cargo oil tanks in compliance with regulation 18.3.

49.1.3 The Administration may accept piping arrangements which are led to the ship's side discharge outlet located above the departure ballast waterline but not above the waterline in the deepest ballast condition, if such arrangements have been fitted before 1 January 1981.

49.1.4 Although 17.6.4.2 (regulation 30.2) does not preclude the use of the facility referred to in 49.1.1.2 for the discharge of ballast water, it is recognized that the use of this facility is not desirable, and it is strongly recommended that ships be provided with either the side discharge outlets referred to in 49.1.1.1 or the part flow arrangements referred to in regulation 30.6.5. (MEPC52 Annex 3)

17.6.4.3 In oil tankers of 150 gross tonnage and above (...) means shall be provided for stopping the discharge into the sea of ballast water or oil contaminated water from cargo tank areas, other than those discharges below the waterline permitted under 17.6.4.4 (paragraph 6 of this regulation), from a position on the upper deck or above located so that the manifold in use referred to in 17.6.4.1 (paragraph 1 of this regulation) and the discharge to the sea from the pipelines referred to in 17.6.4.2 (paragraph 2 of this regulation) may be visually observed. Means for stopping the discharge need not be provided at the observation position if a positive communication system such as a telephone or radio system is provided between the observation position and the discharge control position. (MARPOL, Reg. I/30.3)

17.6.4.4 On every oil tanker the discharge of ballast water or oil contaminated water from cargo tank areas shall take place above the waterline, except as follows:

- .1 Segregated ballast and clean ballast may be discharged below the waterline:
 - .1 in ports or at offshore terminals, or
 - .2 at sea by gravity, or
 - .3 at sea by pumps if the ballast water exchange is performed under the provisions of regulation D-1.1 of the *International Convention for the Control and Management of Ships' Ballast Water and Sediments*.

provided that the surface of the ballast water has been examined either visually or by other means immediately before the discharge to ensure that no contamination with oil has taken place.

- .4 On every oil tanker at sea, dirty ballast water or oil contaminated water from tanks in the cargo area, other than slop tanks, may be discharged by gravity below the waterline, provided that sufficient time has elapsed in order to allow oil/water separation to have taken place and the ballast water has been examined immediately before the discharge with an oil/water interface detector referred to in 17.6.4.9 (regulation 32 of this Annex), in order to ensure that the height of the interface is such that the discharge does not involve any increased risk of harm to the marine environment.

(...) (MARPOL, Reg. I/30.6)

17.6.4.5 (...) oil tankers of 150 gross tonnage and above shall be equipped with an oil discharge monitoring and control system approved by the Administration. (MARPOL, Reg. I/31.1)

17.6.4.6 In considering the design of the oil content meter to be incorporated in the system, the Administration shall have regard to the specification recommended by the Organization.* The system shall be fitted with a recording device to provide a continuous record of the discharge in litres per nautical mile and total quantity discharged, or the oil content and rate of discharge. This record shall be identifiable as to time and date and shall be kept for at least three years. The oil discharge monitoring and control system shall come into operation when there is any discharge of effluent into the sea and shall be such as will ensure that any discharge of oily mixture is automatically stopped when the instantaneous rate of discharge of oil exceeds that permitted by regulation 34 of this Annex (i.e. 30 litres/nautical mile). Any failure of this monitoring and control system shall stop the discharge. In the event of failure of the oil discharge monitoring and control system a manually operated alternative method may be used, but the defective unit shall be made operable as soon as possible. (...). (MARPOL, Reg. I/31.2)

* (...) For oil content meters as part of discharge monitoring and control systems installed on oil tankers built on or after 1 January 2005, refer to *Revised Guidelines and Specifications for Oil Discharge Monitoring and Control Systems for Oil Tankers* (resolution MEPC.108(49), as amended by resolution MEPC.240(65)).

17.6.4.7 The oil discharge monitoring and control system shall be designed and installed in compliance with the guidelines and specifications for oil discharge monitoring and control system for oil tankers developed by the Organization*. Administrations may accept such specific arrangements as detailed in the Guidelines and Specifications. (MARPOL, Reg. I/31.3)

* Refer to (...) *Revised Guidelines and Specifications for Oil Discharge Monitoring and Control Systems for Oil Tankers* (resolution MEPC.108(49), as amended by resolution MEPC.240(65)) (...).

17.6.4.8 Instructions as to the operation of the system shall be in accordance with an operational manual* approved by the Administration. They shall cover manual as well as automatic operations and shall be intended to ensure that at no time shall oil be discharged except in compliance with the conditions specified in regulation 34 of this Annex. (MARPOL, Reg. I/31.4)

*** IACS interpretation**

For compliance with 17.6.4.8 (Regulation 31.4 of MARPOL – Annex I and Resolution MEPC.108(49) as amended by Resolution MEPC.240(65)), the Oil Discharge Monitoring and Control System Operational Manual is to contain all the details necessary to operate and maintain the system and should include at least the following information. The information may be grouped as indicated, or in an equivalent manner.

Introduction : Particulars of the ship, together with the date on which the system was/is to be installed and index to remainder of manual.

Text of Regulations 31 and 34 to be quoted in full.

Section 1: Manufacturer's equipment manuals for major components of the system. These may include installation, commissioning, operating and fault finding procedures for the oil content monitor.

Section 2: Operations manual comprising a description of the ship's cargo ballast systems, designated overboard discharges with sampling points, normal operational procedures, automatic inputs, manual inputs (as applicable), starting interlock and discharge valve control (as applicable), override system, audible and visual alarms, outputs recorded and, where required for manual input, flow rate when discharging by gravity and when pumping ballast overboard. It should also include instructions for the discharge of oily water following mal-function of the equipment.

The above information is to be supported by copies of relevant approved diagrams.

Reference may be made to Section 1, where applicable.

Section 3: Technical manual comprising fault finding schedules, maintenance record and electrical, pneumatic and hydraulic schematic diagrams and descriptions of the complete system.

Reference may be made to Section 1, where applicable.

Section 4: Test and check-out procedures to include a functional test at installation and guidance notes for the Surveyors carrying out initial and in-service surveys.

Reference may be made to Section 1, where applicable.

Appendix I: Technical installation specification including location and mounting of components, arrangements for maintaining integrity of 'safe' zones, safety requirements for electrical equipment installed in hazardous zones supported by copies of approved drawings, sample piping layout and sample delay calculations, design and arrangements of sampling probes, flushing arrangements and zero setting.

Reference may be made to Section 1, where applicable.

Appendix II: Copy of Type Approval Certificate and Workshop Certificates for major components. (IACS UI MPC2)

17.6.4.9 (...) oil tankers of 150 gross tonnage and above shall be provided with effective oil/water interface detectors* approved by the Administration for a rapid and accurate determination of the oil/water interface in slop tanks and shall be available for use in other tanks where the separation of oil and water is effected and from which it is intended to discharge effluent direct to the sea. (MARPOL, Reg. I/32)

This regulation also applies to ships other than oil tankers carrying oil in bulk.

* Refer to the Specifications for Oil/Water Interface Detectors adopted by the Organization by resolution MEPC.5(XIII)

17.6.5 Crude oil washing system – Mark: COW

17.6.5.1 Every crude oil tanker of 20 000 tonnes deadweight and above* (...), shall be fitted with a cargo tank cleaning system using crude oil washing. The Administration shall ensure that the system fully complies with the requirements of this regulation within one year after the tanker was first engaged in the trade of carrying crude oil or by the end of the third voyage carrying crude oil suitable for crude oil washing, whichever occurs later. (MARPOL, Reg. I/33.1)

* *IMO interpretation*

When an oil tanker is used as a floating facility to receive dirty ballast discharged from oil tankers, such a tanker is not required to comply with the provisions of 17.6.5.1 to 17.6.5.3 (regulations (...) 33) (...). (MEPC52 Annex 3)

17.6.5.2 Crude oil washing installation and associated equipment and arrangements shall comply with the requirements established by the Administration. Such requirements shall contain at least all the provisions of the Specifications for the Design, Operation and Control of Crude Oil Washing Systems adopted by the Organization*. When a ship is not required, in accordance with 17.6.5.1 (paragraph 1 of this regulation) to be, but is equipped with crude oil washing equipment, it shall comply with the safety aspects of the above-mentioned Specifications. (MARPOL, Reg. I/33.2)

* Refer to the revised *Specifications for the design, operation and control of crude oil washing systems* adopted by the Organization by resolution A.446(XI) and amended by the Organization by resolution A.497(XII) and as further amended by resolution A.897(21).

17.6.5.3 Every oil tanker* operating with crude oil washing systems shall be provided with an Operations and Equipment Manual* detailing the system and equipment and specifying operational procedures. Such a Manual shall be to the satisfaction of the Administration and shall contain all the information set out in the specifications referred to in 17.6.5.2 (paragraph 2 of regulation 33 of this Annex). If an alteration affecting the crude oil washing system is made, the Operations and Equipment Manual shall be revised accordingly. (MARPOL, Reg. I/35.1)

* *IMO interpretation*

When an oil tanker is used as a floating facility to receive dirty ballast discharged from oil tankers, such a tanker is not required to comply with the provisions of 17.6.5.3 to 17.6.5.5 (regulations (...) 35). (MEPC52 Annex 3)

* Refer to the *Standard Format of the Crude Oil Washing Operation and Equipment Manual* adopted by the Marine Environment Protection Committee of the Organization by resolution MEPC.3(XII), as amended by resolution MEPC.81(43).

17.6.5.4 With respect to the ballasting of cargo tanks, sufficient cargo tanks shall be crude oil washed prior to each ballast voyage in order that, taking into account the tanker's trading pattern and expected weather conditions, ballast water is put only into cargo tanks which have been crude oil washed. (MARPOL, Reg. I/35.2)

17.6.5.5 Unless an oil tanker carries crude oil which is not suitable for crude oil washing, the oil tanker shall operate the crude oil washing system in accordance with the Operations and Equipment Manual. (MARPOL, Reg. I/35.3)

17.6.6 Cargo tank venting, inerting, purging, gas freeing and gauging

17.6.6.1 General requirements for cargo tank venting

17.6.6.1.1 The venting systems of cargo tanks are to be entirely distinct from the air pipes of the other compartments of the ship. The arrangements and position of openings in the cargo tank deck from which emission of flammable vapours can occur shall be such as to minimize the possibility of flammable vapours being admitted to enclosed spaces containing a source of ignition, or collecting in the vicinity of deck machinery and equipment which may constitute an ignition hazard. In accordance with this general principle, the criteria in 17.6.6.2.1 to 17.6.6.5.1 (paragraphs 5.3.2 to 5.3.5) and 17.6.6.8.1 to 17.6.6.8.8 (regulation 11.6) will apply. (SOLAS, Reg. II-2/4.5.3.1)

17.6.6.2 Venting arrangements

17.6.6.2.1 The venting arrangements in each cargo tank may be independent or combined with other cargo tanks and may be incorporated into the inert gas piping. (SOLAS, Reg. II-2/4.5.3.2.1)

Note:

Requirements for the inert gas system – see *Part V*, 11.6.6 and 11.6.4.1.

17.6.6.2.2 Where the arrangements are combined with other cargo tanks, either stop valves or other acceptable means shall be provided to isolate each cargo tank. Where stop valves are fitted, they shall be provided with locking arrangements which shall be under the control of the responsible ship's officer. There shall be a clear visual indication of the operational status of the valves or other acceptable means. Where tanks have been isolated, it shall be ensured that relevant isolating valves are opened before cargo loading or ballasting or discharging of those tanks is commenced. Any isolation must continue to permit the flow caused by thermal variations in a cargo tank in accordance with 17.6.6.8.1.1 (regulation 11.6.1.1). (...), any isolation shall also continue to permit the passage of large volumes of vapour, air or inert gas mixtures during cargo loading and ballasting, or during discharging in accordance with 17.6.6.8.1.2 (regulation 11.6.1.2). (SOLAS, Reg. II-2/4.5.3.2.2)

IACS interpretation

Secondary means of venting cargo tanks shall comply with the following:

1. A P/V breaker fitted on the IG main may be utilised as the required secondary means of venting where the cargo is homogenous or for multiple cargoes where the vapours are compatible and do not require isolation.
2. The height requirements of 17.6.6.4.1 and 17.6.6.8.2 (Reg. II-2/4.5.3.4.1 and 11.6.2) and the requirements for devices to prevent the passage of flame of 17.6.6.3.1 (Reg. II-2/4.5.3.3) are not applicable to the P/V breaker provided the settings are above those of the venting arrangements required by 17.6.6.8.1 (Reg. II-2/11.6.1).
3. Where the venting arrangements are of the free flow type and the masthead isolation valve is closed for the unloading condition, the IG systems will serve as the primary underpressure protection with the P/V breaker serving as the secondary means.
4. Inadvertent closure or mechanical failure of the isolation valves required by 17.6.6.2.2 (SOLAS Reg. II-2/4.5.3.2.2) and the FSS Code, Ch. 15, 2.3.2.2 need not be considered in establishing the secondary means where the cargo is homogenous or for multiple cargoes where the vapours are compatible and do not require isolation since:
 - a) The valves are operated under the control of the responsible ships officer and a clear visual indication of the operational status of the valves is required by 17.6.6.2.2 (SOLAS Reg. II-2/4.5.3.2.2), as amended, and
 - b) The possibility of mechanical failure of the valves is remote due to their simplicity.
5. For ships that apply pressure sensors in each tank as an alternative secondary means of venting as per 17.6.6.8.5 (SOLAS Reg. II-2/11.6.3.2), the setting of the over-pressure alarm shall be above the pressure setting of the P/V-valve and the setting of the under-pressure alarm shall be below the vacuum setting of the P/V-valve. The alarm settings are to be within the design pressures of the cargo tanks. The settings are to be fixed and not arranged for blocking or adjustment in operation*. (IACS UI SC140)

* An exception is permitted for ships that carry different types of cargo and use P/V valves with different settings, one setting for each type of cargo. The settings may be adjusted to account for the different types of cargo.

17.6.6.2.3 If cargo loading and ballasting or discharging of a cargo tank or cargo tank group is intended, which is isolated from a common venting system, that cargo tank or cargo tank group shall be fitted with a means for over-pressure or under-pressure protection as required in 17.6.6.19 (regulation 11.6.3.2). (SOLAS, Reg. II-2/4.5.3.2.3)

17.6.6.2.4 The venting arrangements shall be connected to the top of each cargo tank and shall be self-draining to the cargo tanks under all normal conditions of trim and list of the ship. Where it may not be possible to provide self-draining lines, permanent arrangements shall be provided to drain the vent lines to a cargo tank. (SOLAS, Reg. II-2/4.5.3.2.4)

17.6.6.3 Safety devices in venting systems

17.6.6.3.1 The venting system shall be provided with devices to prevent the passage of flame into the cargo tanks. The design, testing and locating of these devices shall comply with the requirements established by the Administration based on the guidelines developed by the Organization.* Ullage openings** shall not be used for pressure equalization. They shall be provided with self-closing and tightly sealing covers. Flame arresters and screens are not permitted in these openings. (SOLAS, Reg. II-2/4.5.3.3)

* Refer to *Revised standards for the design, testing and locating of devices to prevent the passage of flame into cargo tanks in tankers* (MSC/Circ.677), as amended and *Revised factors to be taken into consideration when designing cargo tank venting and gas-freeing arrangements* (MSC/Circ.731).

**** IACS and IMO interpretation**

- 1 *Ullage openings do not include cargo tank openings that are fitted with standpipe arrangements with their own manually operated shutoff valves.*
- 2 *Examples include the common 2.54 cm (1") and 5.08 cm (2") diameter standpipe arrangements that are used for sampling, monitoring or measuring of ullage/temperature/interface, oxygen, liquid and hand dipping in the cargo tank. (IACS UI SC173, MSC/Circ.1169)*

17.6.6.4 Vent outlets for cargo handling and ballasting

17.6.6.4.1 Vent outlets for cargo loading, discharging and ballasting required by 17.6.6.8.1.2 (regulation 11.6.1.2) shall:

- .1.1 permit the free flow of vapour mixtures; or
- .1.2 permit the throttling of the discharge of the vapour mixtures to achieve a velocity of not less than 30 m/s;
- .2 be so arranged that the vapour mixture is discharged vertically upwards;
- .3 where the method is by free flow of vapour mixtures, be such that the outlet shall be not less than 6 m above the cargo tank deck or fore and aft gangway if situated within 4 m of the gangway and located not less than 10 m measured horizontally from the nearest air intakes and openings to enclosed spaces containing a source of ignition and from deck machinery, which may include anchor windlass and chain locker openings, and equipment which may constitute an ignition hazard; and
- .4 where the method is by high-velocity discharge, be located at a height not less than 2 m above the cargo tank deck and not less than 10 m measured horizontally from the nearest air intakes and openings to enclosed spaces containing a source of ignition and from deck machinery, which may include anchor windlass and chain locker openings, and equipment which may constitute an ignition hazard. These outlets shall be provided with high velocity devices of an approved type. (SOLAS, Reg. II-2/4.5.3.4.1)

IACS and IMO interpretation

Electrical equipment fitted in compliance with IEC 60092-502:1999 is not considered a source of ignition or ignition hazard. (IACS UI SC57, MSC/Circ.1120 amended by MSC.1/Circ.1436 and MSC.1/Circ.1510)

17.6.6.4.2 The arrangements for the venting of vapours displaced from the cargo tanks during loading and ballasting shall comply with 17.6.6.1.1 to 17.6.6.5.1 (paragraph 5.3) and 17.6.6.8.1 to 17.6.6.8.8 (regulation 11.6) and shall consist of either one or more mast risers, or a number of high-velocity vents. The inert gas supply main may be used for such venting. (SOLAS, Reg. II-2/4.5.3.4.2)

The arrangements for the discharge of vapours of highly volatile oil products having a Reid vapour pressure above atmospheric pressure are subject to PRS acceptance in each particular case.

17.6.6.5 Isolation of slop tanks in combination carriers

17.6.6.5.1 In combination carriers, the arrangements for isolating slop tanks containing oil or oil residues from other cargo tanks (in the case of common venting arrangements) shall consist of blank flanges which will remain in position at all times when cargoes other than liquid cargoes referred to in regulation 1.6.1 (i.e. crude oil or petroleum products having a flashpoint not exceeding 60°C) are carried. (SOLAS, Reg. II-2/4.5.3.5)

17.6.6.6 General requirements for inert gas systems

17.6.6.6.1 The inert gas system shall be capable of inerting, purging and gas-freeing empty tanks and maintaining the atmosphere in cargo tanks with the required oxygen content. (SOLAS, Reg. II-2/4.5.5.3.1)

Inert gas system shall be connected to the stern and bow loading and unloading lines (if any) and it shall be capable of being efficiently separated from these lines.

17.6.6.6.2 Tankers fitted with a fixed inert gas system shall be provided with a closed ullage system. (SOLAS, Reg. II-2/4.5.5.3.2)

IMO interpretation

“Closed ullage system” means a system which allows cargo measurement without breaking the integrity of the tank. (MSC/Circ.1120)

Note:

Remaining detailed requirements for the inert gas system – see Part V, 11.6.6 and 11.6.4.1.

17.6.6.7 Inerting, purging and gas-freeing

17.6.6.7.1 Arrangements for purging and/or gas-freeing shall be such as to minimize the hazards due to dispersal of flammable vapours in the atmosphere and to flammable mixtures in a cargo tank. (SOLAS, Reg. II-2/4.5.6.1)

IMO interpretation

The outlets mentioned in 17.6.6.7.1 (regulation II-2/4.5.6.1) should be located in compliance with 17.6.6.4.1.3 (regulation II-2/4.5.3.4.1.3) as far as the horizontal distance is concerned.

Refer to MSC/Circ.677, as amended by MSC/Circ.1009 – Revised standards for the design, testing and locating of devices to prevent the passage of flame into cargo tanks in tankers, and to MSC/Circ.731 – Revised factors to be taken into consideration when designing cargo tank venting and gas-freeing arrangements. (MSC/Circ.1120)

Note:

MSC/Circ.677 has been amended by MSC.1/Circ.1324 – *Amendments to the revised standards for the design, testing and location of devices to prevent the passage of flame into cargo tanks in tankers (MSC/Circ.677, as amended by MSC/Circ.1009)*

17.6.6.7.2 The arrangements for inerting, purging or gas-freeing of empty tanks as required in 17.6.6.6.1 (paragraph 5.5.3.1) shall be to the satisfaction of the Administration and shall be such that the accumulation of hydrocarbon vapours in pockets formed by the internal structural members in a tank is minimized and that:

- .1 on individual cargo tanks, the gas outlet pipe, if fitted, shall be positioned as far as practicable from the inert gas/air inlet and in accordance with 17.6.6.1.1 to 17.6.6.5.1 (paragraph 5.3) and 17.6.6.8.1 to 17.6.6.8.8 (regulation 11.6). The inlet of such outlet pipes may be located either at deck level or at not more than 1 m above the bottom of the tank;
- .2 the cross-sectional area of such gas outlet pipe referred to in 17.6.6.7.2.1 (paragraph 5.6.3.1) shall be such that an exit velocity of at least 20 m/s can be maintained when any three tanks are being simultaneously supplied with inert gas. Their outlets shall extend not less than 2 m above deck level; and
- .3 each gas outlet referred to in 17.6.6.7.2.2 (paragraph 5.6.3.2) shall be fitted with suitable blanking arrangements. (SOLAS, Reg. II-2/4.5.6.3)

IACS interpretation

1. *The outlets mentioned in 17.6.6.7.2 (Reg. II-2/4.5.6.3) are to be located in compliance with 17.6.6.4.1.3 (Reg. II-2/4.5.3.4.1.3) as far as the horizontal distance is concerned.*
2. *Reference is made to MSC/Circ.677 – Revised standards for the design, testing and locating of devices to prevent the passage of flame into cargo tanks in tankers, and MSC/Circ.450/Rev.1 – Revised factors to be taken into consideration when designing cargo tank venting and gas-freeing arrangements. (IACS UI SC58)*

Note:

MSC/Circ.677 has been amended by MSC.1/Circ.1324 – *Amendments to the revised standards for the design, testing and location of devices to prevent the passage of flame into cargo tanks in tankers (MSC/Circ.677, as amended by MSC/Circ.1009)*.

17.6.6.7.3 Fans used for ventilation of tanks shall meet the requirements specified in *Part VII*, 5.3.2. Where the fans are fixed, provision shall be made to ensure their effective isolation from the tanks by means of portable spool pieces or blank flanges.

17.6.6.8 Protection of cargo tank structure against pressure or vacuum

17.6.6.8.1 The venting arrangements shall be so designed and operated as to ensure that neither pressure nor vacuum in cargo tanks shall exceed design parameters and be such as to provide for:

- .1 the flow of the small volumes of vapour, air or inert gas mixtures caused by thermal variations in a cargo tank in all cases through pressure/vacuum valves; and
- .2 the passage of large volumes of vapour, air or inert gas mixtures during cargo loading and ballasting, or during discharging. (SOLAS, Reg. II-2/11.6.1)

17.6.6.8.2 Openings for pressure release required by 17.6.6.8.1.1 (paragraph 6.1.1) shall:

- .1 have as great a height as is practicable above the cargo tank deck to obtain maximum dispersal of flammable vapours, but in no case less than 2 m above the cargo tank deck; and
- .2 be arranged at the furthest distance practicable but not less than 5 m from the nearest air intakes and openings to enclosed spaces containing a source of ignition and from deck

machinery and equipment which may constitute an ignition hazard. Anchor windlass and chain locker openings constitute an ignition hazard.

(...), the openings shall be arranged in accordance with 17.6.6.4.1 (regulation 4.5.3.4.1). (SOLAS, Reg. II-2/11.6.2)

17.6.6.8.3 PV valves to (cargo) oil tanks should not be set at pressures in excess of 0,21 bar unless the tank scantlings have been specially considered. (IACS UR F8)

17.6.6.8.4 Provisions shall be made to guard against liquid rising in the venting system to a height which would exceed the design head of cargo tanks. This shall be accomplished by high-level alarms or overflow control systems or other equivalent means, together with independent gauging devices and cargo tank filling procedures. For the purposes of this regulation, spill valves are not considered equivalent to an overflow system. (SOLAS, Reg. II-2/11.6.3.1)

17.6.6.8.5 A secondary means of allowing full flow relief of vapour, air or inert gas mixtures to prevent over-pressure or under-pressure in the event of failure of the arrangements in 17.6.6.8.1.2 (paragraph 6.1.2) shall be provided. In addition, (...), the secondary means shall be capable of preventing over-pressure or under-pressure in the event of damage to, or inadvertent closing of, the means of isolation required in 17.6.6.2.2 (regulation 4.5.3.2.2). Alternatively, pressure sensors may be fitted in each tank protected by the arrangement required in 17.6.6.8.1.2 (paragraph 6.1.2), with a monitoring system in the ship's cargo control room or the position from which cargo operations are normally carried out. Such monitoring equipment shall also provide an alarm facility which is activated by detection of over-pressure or under-pressure conditions within a tank. (SOLAS, Reg. II-2/11.6.3.2)

IACS interpretation

1. A P/V breaker fitted on the IG main may be utilised as the required secondary means of venting where the cargo is homogenous or for multiple cargoes where the vapours are compatible and do not require isolation.
2. The height requirements of 17.6.6.4.1 (Reg. II-2/4.5.3.4.1) and 17.6.6.8.2 (11.6.2) and the requirements for devices to prevent the passage of flame of 17.6.6.3.1 (Reg. II-2/4.5.3.3) are not applicable to the P/V breaker provided the settings are above those of the venting arrangements required by 17.6.6.8.1 (Reg. II-2/11.6.1).
3. Where the venting arrangements are of the free flow type and the masthead isolation valve is closed for the unloading condition, the IG systems will serve as the primary underpressure protection with the P/V breaker serving as the secondary means.
4. Inadvertent closure or mechanical failure of the isolation valves required by 17.6.6.2.2 (SOLAS Reg. II-2/4.5.3.2.2) and the FSS Code, Ch. 15, 2.3.2.2 need not be considered in establishing the secondary means where the cargo is homogenous or for multiple cargoes where the vapours are compatible and do not require isolation since:
 - a) The valves are operated under the control of the responsible ships officer and a clear visual indication of the operational status of the valves is required by 17.6.6.2.2 (SOLAS Reg. II-2/4.5.3.2.2), as amended, and
 - b) The possibility of mechanical failure of the valves is remote due to their simplicity.
5. For ships that apply pressure sensors in each tank as an alternative secondary means of venting as per 17.6.6.8.5 (SOLAS Reg. II-2/11.6.3.2), the setting of the over-pressure alarm shall be above the pressure setting of the P/V-valve and the setting of the under-pressure alarm shall be below the vacuum setting of the P/V-valve. The alarm settings are to be within the design pressures of the cargo tanks. The settings are to be fixed and not arranged for blocking or adjustment in operation*.

* An exception is permitted for ships that carry different types of cargo and use P/V valves with different settings, one setting for each type of cargo. The settings may be adjusted to account for the different types of cargo. (IACS UISC140)

17.6.6.8.6 Pressure/vacuum valves required by 17.6.6.8.1.1 (paragraph 6.1.1) may be provided with a bypass arrangement when they are located in a vent main or masthead riser. Where such an arrangement is provided there shall be suitable indicators to show whether the bypass is open or closed. (SOLAS, Reg. II-2/11.6.3.3)

17.6.6.8.7 One or more pressure/vacuum-breaking devices shall be provided to prevent the cargo tanks from being subject to:

- .1 a positive pressure, in excess of the test pressure of the cargo tank, if the cargo were to be loaded at the maximum rated capacity and all other outlets are left shut; and
- .2 a negative pressure in excess of 700 mm water gauge if cargo were to be discharged at the maximum rated capacity of the cargo pumps and the inert gas blowers were to fail.

Such devices shall be installed on the inert gas main unless they are installed in the venting system required by 17.6.6.1.1 (regulation 4.5.3.1) or on individual cargo tanks. The location and design of the devices shall be in accordance with 17.6.6.1.1 to 17.6.6.5.1 (regulation 4.5.3) and 17.6.6.8.1 to 17.6.6.8.8 (paragraph 6). (SOLAS, Reg. II-2/11.6.3.4)

17.6.6.8.8 Vent outlets for cargo loading, discharging and ballasting required by 17.6.6.8.1.2 (paragraph 6.1.2) shall be designed on the basis of the maximum designed loading rate multiplied by a factor of at least 1.25 to take account of gas evolution, in order to prevent the pressure in any cargo tank from exceeding the design pressure. The master shall be provided with information regarding the maximum permissible loading rate for each cargo tank and in the case of combined venting systems, for each group of cargo tanks. (SOLAS, Reg. II-2/11.6.4)

17.6.7 Air and sounding pipes

17.6.7.1 Air and sounding pipes serving ballast tanks shall not pass through cargo and slop tanks, unless they fulfil the requirements applicable to cargo pipes specified in 17.6.2.6.

17.6.7.2 Air and sounding pipes serving double bottom fuel oil tanks may be led through the cargo tanks, provided that they are connected by welding and properly fastened, protected against mechanical damage, and have the walls of proper thickness

17.6.7.3 Forepeak's vent heads shall be located as far as practicable from the bow loading arrangements

Additional requirements for air and sounding pipes of forepeak tank are specified in 17.6.2.8.

17.6.7.4 Air pipes of double bottom and double side spaces adjacent to cargo and/or slop tanks shall be led to an open deck in positions, where there is no fire hazard. The outlets shall be protected by flame screens complying with the requirements specified in 17.6.6.6. The clear area through such screens shall not be less than the cross-sectional area of the air pipe.

17.6.8 Exhaust gas system

17.6.8.1 The exhaust gas lines of main and auxiliary engines, boilers, incinerators and galley stoves shall be fitted with spark arresters of a design agreed with PRS.

Alternatively, the pipes may be led overboard through the shell plating, provided that the outlet is arranged at least 0.3 m below the light waterline.

17.6.8.2 The exhaust gas pipe outlets from main and auxiliary engines, boilers, galley stoves and similar equipment constituting ignition sources, as well as the outlets of venting pipes of diesel engines, shall be situated at least 6 m above the maximum draught waterline. In each case they shall be located outside explosion hazardous areas – see *Part VIII*, 22.5.3.

17.6.9 Ventilation systems

17.6.9.1 General

17.6.9.1.1 (...) air inlets and openings to accommodation spaces, service spaces, control stations and machinery spaces shall not face the cargo area. They shall be located on the transverse bulkhead not facing the cargo area or on the outboard side of the superstructure or deckhouse at a distance of at least 4% of the length of the ship but not less than 3 m from the end of the superstructure or deckhouse facing the cargo area. This distance need not exceed 5 m. (SOLAS, Reg. II-2/4.5.2.1)

17.6.9.1.2 The arrangement of ventilation inlets and outlets and other deckhouse and superstructure boundary space openings shall be such as to complement the provisions of 17.6.6.1 to 17.6.6.9 (paragraph 5.3) and 17.6.6.15 to 17.6.6.22 (regulation 11.6). Such vents, especially for machinery spaces, shall be situated as far aft as practicable. Due consideration in this regard shall be given when the ship is equipped to load or discharge at the stern. Sources of ignition such as electrical equipment shall be so arranged as to avoid an explosion hazard. (SOLAS, Reg. II-2/4.5.2.6)

17.6.9.2 Cargo pump room ventilation system

17.6.9.2.1 Cargo pump-rooms shall be mechanically ventilated and discharges from the exhaust fans shall be led to a safe place on the open deck. The ventilation of these rooms shall have sufficient capacity to minimize the possibility of accumulation of flammable vapours. The number of air changes shall be at least 20 per hour, based upon the gross volume of the space. The air ducts shall be arranged so that all of the space is effectively ventilated. The ventilation shall be of the suction type using fans of the non-sparking type (see *Part VII*, 5.3.2). (SOLAS, Reg. II-2/4.5.4.1)

17.6.9.2.2 Cargo pump-rooms ventilation systems shall be independent from ventilation systems serving other spaces.

17.6.9.2.3 Additionally the cargo pump-rooms ventilation systems shall comply with the following:

With the following arrangement of exhaust trunking there should be 20 air changes per hour on the total volume of the pump room:

- (i) In the pump room bilges just above the transverse floor plates on bottom longitudinals, so that air can flow over the top from adjacent spaces.
- (ii) An emergency intake located about 2 m above the pump room lower grating. This emergency intake would be used when the lower intakes are sealed off due to flooding in the bilges. The emergency intake should have a damper fitted which is capable of being opened or closed from the exposed main deck and lower grating level.
- (iii) The foregoing exhaust system is in association with open grating floor plates to allow the free flow of air.
- (iv) Arrangements involving a specific ratio of areas of upper emergency and lower main ventilator openings, which can be shown to result in at least the required 20 air changes per hour through the lower inlets, can be adopted without the use of dampers. When the lower access inlets are closed then at least 15 air changes per hour should be obtained through the upper inlets. (IACS UR F21)

17.6.9.2.4 The position of exhaust ducts outlets from cargo pump-rooms shall be arranged at a distance of at least 3 m measured horizontally from any ignition source and from the nearest opening or air intake to accommodation spaces, service spaces, control stations or machinery spaces.

17.6.9.2.5 Pump-room fans shall be of non-sparking construction and fulfil the requirements of *Part VII*, 5.3.2 and their controls shall fulfil the requirements of *Part VIII*, 22.5.7.2.

Inlet and outlet ventilation openings of the cargo pump-rooms ventilation systems shall be fitted with suitable wire mesh guards (the mesh size not exceeding 13 x 13 mm).

17.6.9.2.6 Electric motors intended for the drive of fans located in cargo pump-room shall be installed in adjacent spaces fitted with mechanical ventilation and having no exits to the cargo pump rooms.

17.6.9.2.7 Where drive shafts pass through pump room bulkhead or deck plating, gastight glands are to be fitted. The glands are to be efficiently lubricated from outside the pumproom. The seal parts of the glands are to be of material that will not initiate sparks. The glands are to be constructed and fitted in accordance with the relative rules for fittings attached to watertight bulkheads, and if a bellows piece is incorporated in the design, it should be pressure tested before fitting. (IACS UR F13)

17.6.9.2.8 Skylights to cargo pump-rooms shall be of steel, shall not contain any glass and shall be capable of being closed from outside the pump-room. (SOLAS, Reg. II-2/9.2.4.2.6)

17.6.9.3 Other requirements concerning ventilation

17.6.9.3.1 In spaces intended for inert gas equipment, such as gas generators, scrubbers, fans and their fittings, an exhaust ventilation system shall be provided ensuring at least 6 air changes per hour calculated for empty space. Supply ventilation may be natural.

17.6.9.3.2 In combination carriers, cargo spaces and any enclosed spaces adjacent to cargo spaces shall be capable of being mechanically ventilated. The mechanical ventilation may be provided by portable fans. (...) (SOLAS, Reg. II-2/4.5.4.2)

17.6.9.3.3 Double hull and double bottom spaces shall be fitted with suitable connections for the supply of air. (SOLAS, Reg. II-2/4.5.8)

17.6.9.3.4 Pipe ducts in the double bottom (under cargo oil tanks) shall comply with the following requirements:

(i) (...)

(iii) In the duct, provision shall be made for adequate mechanical ventilation. (IACS UR F26)

17.6.10 Fuel systems

17.6.10.1 Double bottom oil fuel tanks shall fulfil the following requirements:

- access manholes to the tanks shall not be located in cargo spaces and engine room,
- piping serving these tanks shall not be led through cargo and slop tanks and shall not be interconnected with pipelines serving the cargo or slop tanks (see also 17.6.7.2).

17.6.10.2 Requirements concerning use of crude oil or slops as fuel for tanker boilers

IACS UR M24

Note:

See 8.1.1.4 which permits the use of crude oil as fuel.

17.6.10.2.1 In tankers crude oil or slops may be used as fuel for main or auxiliary boilers according to the following requirements. For this purpose all arrangement drawings of a crude oil

installation with pipeline layout and safety equipment are to be submitted for approval in each case. **(M24.1)**

17.6.10.2.2 Crude oil or slops may be taken directly from cargo tanks or flow slop tanks or from other suitable tanks. These tanks are to be fitted in the cargo tank area and are to be separated from non-gas-dangerous areas by means of cofferdams with gas-tight bulkheads. **(M24.2)**

17.6.10.2.3 The construction and workmanship of the boilers and burners are to be proved to be satisfactory in operation with crude oil.

The whole surface of the boilers shall be gas-tight separated from the engine room. The boilers themselves are to be tested for gas-tightness before being used. The whole system of pumps, strainers, separators and heaters, if any, shall be fitted in the cargo pump room or in another room, to be considered as dangerous, and separated from engine and boiler room by gas-tight bulkheads. When crude oil is heated by steam or hot water the outlet of the heating coils should be led to a separate observation tank installed together with above mentioned components. This closed tank is to be fitted with a venting pipe led to the atmosphere in a safe position according to the rules for tankers and with the outlet fitted with a suitable flame proof wire gauze of corrosion resistant material which is to be easily removable for cleaning. **(M24.3)**

17.6.10.2.4 Electric, internal combustion and steam (when the steam temperature is higher than 220°C) prime movers of pumps, of separators (if any), etc., shall be fitted in the engine room or in another non-dangerous room.

Where drive shafts pass through pump room bulkhead or deck plating, gas-tight glands are to be fitted.

The glands are to be efficiently lubricated from outside the pump room. **(M24.4)**

17.6.10.2.5 Pumps shall be fitted with a pressure relief bypass from delivery to suction side and it shall be possible to stop them by a remote control placed in a position near the boiler fronts or machinery control room and from outside the engine room. **(M24.5)**

17.6.10.2.6 When it is necessary to preheat crude oil or slops, their temperature is to be automatically controlled and a high temperature alarm is to be fitted. **(M24.6)**

17.6.10.2.7 The piping for crude oil or slops and the draining pipes for the tray defined in M24.9 are to have a thickness as follows:

External diameter of pipes, d_e thickness, t

$$d_e \leq 82,5 \text{ mm} \quad t \geq 6,3 \text{ mm}$$

$$88,9 \text{ mm} < d_e \leq 108 \text{ mm} \quad t \geq 7,1 \text{ mm}$$

$$114,3 \text{ mm} < d_e \leq 139,7 \text{ mm} \quad t \geq 8 \text{ mm}$$

$$152,4 \text{ mm} \leq d_e \quad t \geq 8,8 \text{ mm}$$

Their connections (to be reduced to a minimum) are to be of the heavy flange type. Within the engine room and boiler room these pipes are to be fitted within a metal duct, which is to be gas-tight and tightly connected to the fore bulkhead separating the pump room and to the tray. This duct (and the enclosed piping) is to be fitted at a distance from the ship's side of at least 20% of the vessel's beam amidships and be at an inclination rising towards the boiler so that the oil naturally returns towards the pump room in the case of leakage or failure in delivery pressure. It is to be fitted with inspection openings with gas-tight doors in way of connections of pipes within it, with an automatic closing drain-trap placed on the pump room side, set in such a way as to discharge leakage of crude oil into the pump room.

In order to detect leakages, level position indicators with relevant alarms are to be fitted on the drainage tank defined in M24.9. Also a vent pipe is to be fitted at the highest part of the duct and is to be led to the open in a safe position. The outlet is to be fitted with a suitable flame proof wire gauze of corrosion-resistant material which is to be easily removable for cleaning.

The duct is to be permanently connected to an approved inert gas system or steam supply in order to make possible:

- injection of inert gas or steam in the duct in case of fire or leakage
- purging of the duct before carrying out work on the piping in case of leakage. (M24.7)

17.6.10.2.8 In way of the bulkhead to which the duct defined in M24.7 is connected, delivery and return oil pipes are to be fitted on the pump room side, with shut-off valves remotely controlled from a position near the boiler fronts or from the machinery control room. The remote control valves should be interlocked with the hood exhaust fans (defined in M24.10) to ensure that whenever crude oil is circulating the fans are running. (M24.8)

17.6.10.2.9 Boilers shall be fitted with a tray or gutterway of a height to the satisfaction of the Classification Society and be placed in such a way as to collect any possible oil leakage from burners, valves and connections.

Such a tray or gutterway shall be fitted with a suitable flame proof wire gauze, made of corrosion resistant material and easily dismountable for cleaning. Delivery and return oil pipes shall pass through the tray or gutterway by means of a tight penetration and shall then be connected to the oil supply manifolds.

A quick closing master valve is to be fitted on the oil supply to each boiler manifold.

The tray or gutterway shall be fitted with a draining pipe discharging into a collecting tank in pump room. This tank is to be fitted with a venting pipe led to the open in a safe position and with the outlet fitted with wire gauze made of corrosion resistant material and easily dismountable for cleaning.

The draining pipe is to be fitted with arrangements to prevent the return of gas to the boiler or engine room. (M24.9)

17.6.10.2.10 Boilers shall be fitted with a suitable hood placed in such a way as to enclose as much as possible of the burners, valves and oil pipes, without preventing, on the other side, air inlet to burner register.

The hood, if necessary, is to be fitted with suitable doors placed in such a way as to enable inspection of and access to oil pipes and valves placed behind it. It is to be fitted with a duct leading to the open in a safe position, the outlet of which is to be fitted with a suitable flame wire gauze, easily dismountable for cleaning. At least two mechanically driven exhaust fans having spark proof impellers (see *Part VII*, 5.3.2) are to be fitted so that the pressure inside the hood is less than that in the boiler room. The exhaust fans are to be connected with automatic change over in case of stoppage or failure of the one in operation.

The exhaust fan prime movers shall be placed outside the duct and a gas-tight bulkhead penetration shall be arranged for the shaft.

Electrical equipment installed in gas dangerous areas or in areas which may become dangerous (i.e. in the hood or duct in which crude-oil piping is placed) is to be of certified safe type as required by Classification Societies. (M24.10)

17.6.10.2.11 When using fuel oil for delivery to and return from boilers fuel oil burning units in accordance with Classification Societies' Rules shall be fitted in the boiler room. Fuel oil delivery

to, and returns from, burners shall be effected by means of a suitable mechanical interlocking device so that running on fuel oil automatically excludes running on crude oil or vice versa. **(M24.11)**

17.6.10.2.12 The boiler compartments are to be fitted with a mechanical ventilation plant and shall be designed in such a way as to avoid the formation of gas pockets.

Ventilation is to be particularly efficient in way of electrical plants and machinery and other plants which may generate sparks. These plants shall be separated from those for service of other compartments and shall be in accordance with Classification Societies' requirements. **(M24.12)**

17.6.10.2.13 A gas detector plant shall be fitted with intakes in the duct defined in M24.7, in the hood duct (downstream of the exhaust fans in way of the boilers) and in all zones where ventilation may be reduced. An optical warning device is to be installed near the boiler fronts and in the machinery control room. An acoustical alarm, audible in the machinery space and control room, is to be provided. **(M24.13)**

17.6.10.2.14 Means are to be provided for the boiler to be automatically purged before firing. **(M24.14)**

17.6.10.2.15 Independent of the fire extinguishing plant as required by Classification Societies' Rules, an additional fire extinguishing plant is to be fitted in the engine and boiler rooms in such a way that it is possible for an approved fire extinguishing medium to be directed on to the boiler fronts and on to the tray defined in M24.9. The emission of extinguishing medium should automatically stop the exhaust fan of the boiler hood (see M24.8). **(M24.15)**

17.6.10.2.16 A warning notice must be fitted in an easily visible position near the boiler front. This notice must specify that when an explosive mixture is signalled by the gas detector plant defined in M24.13 the watchkeepers are to immediately shut off the remote controlled valves on the crude oil delivery and return pipes in the pump room, stop the relative pumps, inject inert gas into the duct defined in M24.7 and turn the boilers to normal running on fuel oil. **(M24.16)**

17.6.10.2.17 One pilot burner in addition to the normal burning control is required. **(M24.17)**

END OF IACS UR M24

17.6.11 Cargo heating systems

17.6.11.1 On oil tankers, the steam and heating media temperature within the cargo area is not to exceed 220°C. (...) (IACS UR F24)

The pressure of saturated heating steam shall not exceed 2 MPa.

17.6.11.2 Heating of liquid cargoes with a flash point below 60°C shall be arranged by means of a separate secondary system, located completely within the cargo area.

A direct system may also be accepted, provided the following conditions are fulfilled:

- the pressure in every heating section with the circulation pump not running shall be at least 30 kPa higher than the hydrostatic pressure of the liquid;
- expansion tank of the system shall be fitted with high and low oil level alarm sensors;
- means are provided to detect the cargo vapours inside the expansion tank;
- cut-off valves of individual heating sections are fitted with locking arrangements to ensure constant hydrostatic pressure.

17.6.11.3 Thermal oil system shall fulfil the requirements specified in 10.2.

17.6.12 Other provisions

17.6.12.1 In tankers, for the protection of cargo tanks carrying crude oil and petroleum products having a flashpoint not exceeding 60°, materials readily rendered ineffective by heat shall not be used for valves, fittings, tank opening covers, cargo vent piping, and cargo piping so as to prevent the spread of fire to the cargo. (SOLAS, Reg. II-2/9.6.3)

17.7 Chemical tankers – additional mark CHEMICAL TANKER

17.7.1 Chemical tankers' piping systems shall fulfil the requirements specified in the *International Code for Construction and Equipment of Ships Carrying Dangerous Chemicals in Bulk (IBC Code)* as amended including standards and guidelines referred therein. Only those requirements (paragraphs) of *IBC Code* for which interpretations exist are listed below.

17.7.2 The following interpretations apply to *IBC Code* paragraphs:

– **Air intakes, inlets, outlets and openings**

3.2.2 In order to guard against the danger of hazardous vapours, due consideration shall be given to the location of air intakes and openings into accommodation, service and machinery spaces and control stations in relation to cargo piping and cargo vent systems.

IMO interpretation

Compliance with other relevant paragraphs of the Code and in particular with paragraphs 3.2.3, 3.7, 8.2.2, 12.1.5 and 15.12 where applicable would also ensure compliance with this paragraph.

Air outlets are subject to the same requirements as air inlets and air intakes. (...) (MSC/Circ.406/Rev.1)

3.2.3 Entrances, air inlets and openings to accommodation, service and machinery spaces and control stations shall not face the cargo area. They shall be located on the end bulkhead not facing the cargo area and/or on the outboard side of the superstructure or deck house at a distance of at least 4% of the length (L) of the ship but not less than 3 m from the end of the superstructure or deck house facing the cargo area. This distance, however, need not exceed 5 m. No doors shall be permitted within the limits mentioned above, except that doors to those spaces not having access to accommodation and service spaces and control stations, such as cargo control stations and store rooms, may be fitted. Where such doors are fitted, the boundaries of the space shall be insulated to "A-60" standard. Bolted plates for removal of machinery may be fitted within the limits specified above. Wheelhouse doors and wheelhouse windows may be located within the limits specified above so long as they are so designed that a rapid and efficient gas- and vapour- tightening of the wheelhouse can be ensured. Windows and sidescuttles facing the cargo area and on the sides of the superstructures and deck houses within the limits specified above shall be of the fixed (non-opening) type. Such sidescuttles in the first tier on the main deck shall be fitted with inside covers of steel or equivalent material.

IMO interpretation

Air outlets are subject to the same requirements as air inlets and air intakes. (...) (MSC/Circ.406/Rev.1)

3.7.4 Entrances, air inlets and openings to accommodation, service and machinery spaces and control stations shall not face the cargo shore-connection location of bow or stern loading and unloading arrangements. They shall be located on the outboard side of the superstructure or deck house at a distance of at least 4% of the length of the ship but not less than 3 m from the end of the house facing the cargo shore-connection location of the bow or

stern loading and unloading arrangements. This distance, however, need not exceed 5 m. Sidescuttles facing the shore connection location and on the sides of the superstructure or deck-house within the distance mentioned above shall be of the fixed (non-opening) type. In addition, during the use of the bow or stern loading and unloading arrangements, all doors, ports and other openings on the corresponding superstructure or deck-house side shall be kept closed. Where, in the case of small ships, compliance with 3.2.3 and this paragraph is not possible, the Administration may approve relaxations from the above requirements.

IMO interpretation

Air outlets are subject to the same requirements as air inlets and air intakes. (...) (MSC/Circ.406/Rev.1)

– **Tanks used for slops**

3.3.5 Means shall be provided to deal with drainage and any possible leakage from cargo pumps and valves in cargo pump rooms. The bilge system serving the cargo pump room shall be operable from outside the cargo pump room. One or more slop tanks for storage of contaminated bilge water or tank washings shall be provided. A shore connection with a standard coupling or other facilities shall be provided for transferring contaminated liquids to onshore reception facilities.

IMO interpretation

Any cargo tank may be used for holding contaminated cargo pump-room bilge water and cargo tank washings irrespective of the cargo tank location requirements of paragraph 2.6 of the Code. (MSC/Circ.406/Rev.1)

– **Driving shafting seal lubrication**

3.3.7 Where machinery is driven by shafting passing through a bulkhead or deck, gastight seals with efficient lubrication or other means of ensuring the permanence of the gas seal shall be fitted in way of the bulkhead or deck.

IMO interpretation

Lubrication or other means of ensuring permanence of gastight seals should be effected from outside the cargo pump-room. (MSC/Circ.406/Rev.1)

– **Discharge arrangements of permanent ballast tanks**

3.5.1 Pumps, ballast lines, vent lines and other similar equipment serving permanent ballast tanks shall be independent of similar equipment serving cargo tanks and of cargo tanks themselves. Discharge arrangements for permanent ballast tanks sited immediately adjacent to cargo tanks shall be outside machinery spaces and accommodation spaces. Filling arrangements may be in the machinery spaces provided that such arrangements ensure filling from tank deck level and non return valves are fitted.

IMO interpretation

An ejector situated in the cargo area using water power from the machinery spaces is acceptable for discharge purposes provided a non-return valve and means of separation are fitted in the supply line and the supply line is above deck level. A non-return valve and means of separation should be located outside the machinery space (see figure 4).

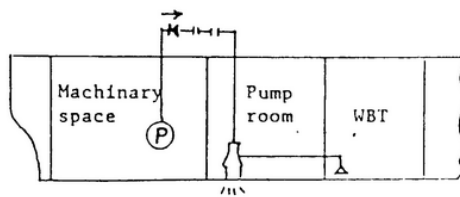

Figure 4 – Discharge arrangement of permanent ballast tanks sited immediately adjacent to cargo tanks (Paragraph 3.5.1)

(MSC/Circ.406/Rev.1)

– **Filling of ballast in cargo tanks**

3.5.2 Filling of ballast in cargo tanks may be arranged from deck level by pumps serving permanent ballast tanks, provided that the filling line has no permanent connection to cargo tanks or piping and that non-return valves are fitted.

IMO interpretation

The filling arrangement may consist of a portable spool piece or flexible hose plus an isolating valve on the inlet to the cargo tank. This isolating valve is in addition to the required non-return valve. Consideration should be given to the arrangement of in-tank piping and the creation of static electricity. (MSC/Circ.406/Rev.1)

– **Bilge pumping from spaces in the cargo area**

3.5.3 Bilge pumping arrangements for cargo pump rooms, pump rooms, void spaces, slop tanks, double-bottom tanks and similar spaces shall be situated entirely within the cargo area except for void spaces, double-bottom tanks and ballast tanks where such spaces are separated from tanks containing cargo or residues of cargo by a double bulkhead.

IMO interpretation

The relaxation at the end of the paragraph should be limited to spaces not enclosing piping which may contain cargo. (MSC/Circ.406/Rev.1)

– **Coamings at bow and stern manifolds**

3.7.7 Continuous coamings of suitable height shall be fitted to keep any spills on deck and away from the accommodation and service areas.

IMO interpretation

The expression "suitable height" should mean the height of coaming to be of approximately 150 mm, however nowhere less than 50 mm above upper edge of sheer strake. (MSC/Circ.406/Rev.1)

– **Cargo piping joining**

5.2.2 Cargo piping shall be joined by welding except:

- .1 for approved connections to shutoff valves and expansion joints; and
- .2 for other exceptional cases specifically approved by the Administration.

IMO interpretation

Cargo piping should be welded except for necessary flanged connections to valves, expansion joints (as permitted in paragraph 5.2.2.1), spool pieces and similar fittings or where required for coating, lining, fabrication, inspection or maintenance. (MSC/Circ.406/Rev.1)

– **Stop valves on cargo piping below the main deck**

5.5.2 Cargo piping located below the main deck may run from the tank it serves and penetrate tank bulkheads or boundaries common to longitudinally or transversally adjacent cargo tanks, ballast tanks, empty tanks, pump rooms or cargo pump rooms provided that inside the tank it serves it is fitted with a stop-valve operable from the weather deck and provided cargo compatibility is assured in the event of piping failure. As an exception, where a cargo tank is adjacent to a cargo pump room, the stop valve operable from the weather deck may be situated on the tank bulkhead on the cargo pump room side, provided an additional valve is fitted between the bulkhead valve and the cargo pump. A totally enclosed hydraulically operated valve located outside the cargo tank may, however, be accepted, provided that the valve is:

.1 designed to preclude the risk of leakage;

(...)

IMO interpretation

The intent is to guard against the hazard of cargo leaking past a valve gland into the space where the valve is located. (MSC/Circ.406/Rev.1)

– **Valves for cargo transfer control system**

5.6.1 For the purpose of adequately controlling the cargo, cargo-transfer systems shall be provided with:

.1 one stop-valve capable of being manually operated on each tank filling and discharge line, located near the tank penetration; if an individual deepwell pump is used to discharge the contents of a cargo tank, a stop-valve is not required on the discharge line of that tank;

(...)

IMO interpretation

The provisions of paragraph 5.6.1.1 are not intended to be additional to those of paragraphs 5.5.2 and 5.5.3 for cargo piping below deck. (MSC/Circ.406/Rev.1)

– **Ship's cargo hoses**

5.7.1 Liquid and vapour hoses used for cargo transfer shall be compatible with the cargo and suitable for the cargo temperature.

IMO interpretation

This paragraph applies to cargo hoses carried on board the vessel and "compatibility with the cargo" means that:

- .1 *the cargo hose does not lose its mechanical strength or deteriorate unduly when in contact with the cargo, and*
- .2 *the cargo hose material does not affect the cargo in a hazardous way. Consideration must be given to internal and external surfaces with respect to the above where hoses may be used as an integral part of, or connected to emergency cargo pumps and submerged in the cargo tank.*

paragraph 5.2.2.1), spool pieces and similar fittings or where required for coating, lining, fabrication, inspection or maintenance. (MSC/Circ.406/Rev.1)

– **Drainage of cargo tank vent lines**

8.2.3 Provision shall be made to ensure that the liquid head in any tank does not exceed the design head of the tank. Suitable high-level alarms, overflow control systems or spill valves, together with gauging and tank filling procedures, may be accepted for this purpose. Where

the means of limiting cargo tank overpressure includes an automatic closing valve, the valve shall comply with the appropriate provisions of 15.19.

IMO interpretation

When large amounts of drainage from vent lines is envisaged provision for a hose connection to a drain line draining to a suitable slop tank should be provided. (MSC/Circ.406/Rev.1)

– **By-passing P/V valves of controlled tank venting system**

8.3.2 A controlled tank venting system is a system in which pressure- and vacuum-relief valves or pressure/vacuum valves are fitted to each tank to limit the pressure or vacuum in the tank. A controlled venting system may consist of individual vents from each tank or such individual vents on the pressure side only as may be combined into a common header or headers, with due regard to cargo segregation. In no case shall shut-off valves be fitted either above or below pressure- or vacuum-relief valves or pressure/vacuum valves. Provision may be made for bypassing a pressure- or vacuum-relief valve or pressure/vacuum valve under certain operating conditions provided that the requirement of 8.3.6 is maintained and that there is suitable indication to show whether or not the valve is bypassed.

IACS and IMO interpretation

By-passing of P/V valves is allowed during cargo operations for cargoes which do not require a vapor return system, provided that the vent-line outlet is fitted with flame arresters and is located at the required height above the deck level. However, by-passing of high-velocity valves is not permitted. (IACS UI CC4, MSC/Circ.1116)

– **Ventilation of pump-rooms and other enclosed spaces normally entered**

12.2 Pump-rooms and other enclosed spaces normally entered which are not covered by 12.1.1 shall be fitted with mechanical ventilation systems, capable of being controlled from outside such spaces and complying with the requirements of 12.1.3, except that the capacity shall not be less than 20 changes of air per hour, based upon the total volume of the space. Provision shall be made to ventilate such spaces prior to personnel entering.

IMO interpretation

A pump-room is subject to this paragraph whether or not control for pumps and valves is fitted external to the pump-room. (MSC/Circ.406/Rev.1)

– **Independency of system**

13.1.1 Cargo tanks shall be fitted with one of the following types of gauging devices:

- .1** *Open device:* which makes use of an opening in the tanks and may expose the gauger to the cargo or its vapour. An example of this is the ullage opening.
- .2** *Restricted device:* which penetrates the tank and which, when in use, permits a small quantity of cargo vapour or liquid to be exposed to the atmosphere. When not in use, the device is completely closed. The design shall ensure that no dangerous escape of tank contents (liquid or spray) can take place in opening the device.
- .3** *Closed device:* which penetrates the tank, but which is part of a closed system and keeps tank contents from being released. Examples are the float-type systems, electronic probe, magnetic probe and protected sight-glass. Alternatively, an indirect device which does not penetrate the tank shell and which is independent of the tank may be used. Examples are weighing of cargo, pipe flow meter.

15.19 Overflow control

IMO interpretation

In almost all cases a code cargo which requires a high level alarm and overflow control also requires a closed gauging device.

A cargo tank containing such a product therefore requires three sensors:

- .1 level gauging;*
- .2 high level alarm;*
- .3 overflow control.*

The sensing elements for .1, .2 and .3 should be separated although sensors for .2 and .3 (reed switches, float chambers, electronic devices, etc.) may be contained in the same tube.

Electronic, pneumatic, hydraulic circuits required for sensors .1, .2 and .3 should be independent of each other such that a fault on any one will not render either of the others inoperative.

Where processing units are used to give digital or visual indication such as in a bridge space the independency of circuitry should be maintained at least beyond this point. The power should be supplied from distribution boards.

Where a control room or a bridge space containing a modular unit is envisaged, separate level indication and visual alarms must be provided for each of the functions .1, .2 or .3. An audible alarm must also be provided but since this is not directional it need not be separate. An audible alarm must also be arranged in the cargo area. Where there is no control room an audible and visual alarm should be arranged at the cargo control station.

Testing of sensors should be arranged from outside the tanks although entry into product clean tanks is not precluded. Simulation testing of electronic circuits or circuits which are self-monitoring is acceptable. (MSC/Circ.406/Rev.1)

– **Restricted device**

13.1.1 Cargo tanks shall be fitted with one of the following types of gauging devices:

(...)

- .2 Restricted device:** which penetrates the tank and which, when in use, permits a small quantity of cargo vapour or liquid to be exposed to the atmosphere. When not in use, the device is completely closed. The design shall ensure that no dangerous escape of tank contents (liquid or spray) can take place in opening the device.

(...)

IACS interpretation

'A restricted device could be a sounding pipe with inside diameter not exceeding 200 mm, with vapour tight cover.'
(IACS UI CC1)

– **Injection of ammonia gas into the cargo**

15.2.6 A fixed installation shall be provided to inject ammonia gas into the cargo. Controls for this system shall be located on the navigation bridge. For this purpose, 300 kg of ammonia per 1,000 tonnes of ammonium nitrate solution shall be available on board.

IMO interpretation

For the purpose of injecting ammonia the cargo may be circulated by means of the cargo pump. Gaseous ammonia may be injected into the circulating cargo. (MSC/Circ.406/Rev.1)

– **Cargo pump design for ammonium nitrate solution**

15.2.7 Cargo pumps shall be of the centrifugal deepwell type or of the centrifugal type with water flushed seals.

IMO interpretation

The seal for the centrifugal pump should be a stuffing box provided with a lantern ring. Fresh water under pressure should be injected into the stuffing box at the location of the lantern ring (see figure 5).

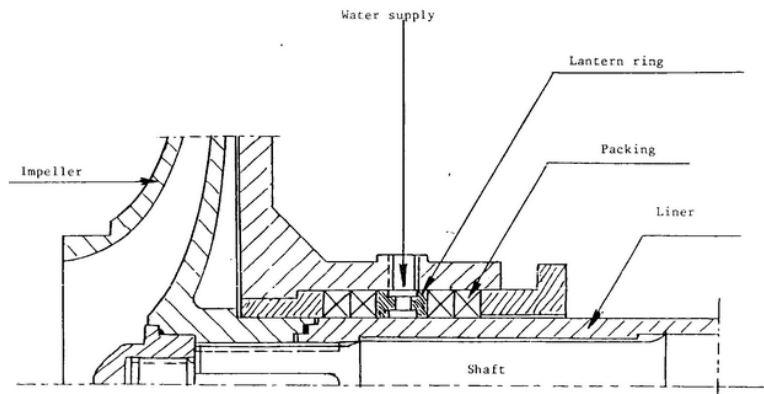

Figure 5 – Water flushed seal in chemical pump
(Paragraph 15.2.7)

(MSC/Circ.406/Rev.1)

– Hydrogen peroxide solution spillage on deck

15.5.1.10 A fixed water-spray system shall be provided for diluting and washing away any concentrated hydrogen peroxide solution spilled on deck. The areas covered by the water-spray shall include the manifold/hose connections and the tank tops of those tanks designated for carrying hydrogen peroxide solutions. The minimum application rate shall satisfy the following criteria:

- .1 The product shall be diluted from the original concentration to 35% by mass within 5 minutes of the spill.
- .2 The rate and estimated size of the spill shall be based upon maximum anticipated loading and discharge rates, the time required to stop flow of cargo in the event of tank overflow or a piping/hose failure, and the time necessary to begin application of dilution water with actuation at the cargo control location or on the navigating bridge.

IMO interpretation

Piping/hose failure should be assumed to be total. (MSC/Circ.406/Rev.1)

– Lining approved for use with acids

15.11.2 Proposals for lining steel tanks and related piping systems with corrosion-resistant materials may be considered by the Administration. The elasticity of the lining shall not be less than that of the supporting boundary plating.

IACS interpretation

"Lining" is an acid-resistant material that is applied to the tank or piping system in a solid state i.e. not spray on total. The requirement for the elasticity of a lining to be not less than the supporting boundary plating is to prevent debonding at the interface between the lining and the lined surface. (IACS UI CC6)

– Connection for a vapour return line for toxic products

15.12.2 Tank venting systems shall be provided with a connection for a vapour-return line to the shore installation.

IACS interpretation

'Tank venting systems should be provided with a stop valve for vapour return line to shore.' (IACS UI CC2)

- **Connection for returning the expelled gases from cargoes with a vapour pressure greater than 0.1013 MPa absolute at 37.8°C**

15.14.4 Connections shall be provided for returning expelled gases to shore during loading.

IACS interpretation

'Tank venting systems should be provided with a stop valve for vapour return line to shore.' (IACS UI CC3)

- **Cargo tank vents for cargoes protected by additives**

15.13.6 Venting systems shall be of a design that eliminates blockage from polymer build-up. Venting equipment shall be of a type that can be checked periodically for adequacy of operation.

IMO interpretation

Internal obstructions should be avoided beyond the requirement for pressure vacuum valves and flame screens which should be accessible for inspection and maintenance. (MSC/Circ.406/Rev.1)

- **Special consideration to cargo pump-rooms below deck**

15.18 For certain products, the cargo pump-room shall be located on the deck level or cargo pumps shall be located in the cargo tank. The Administration may give special consideration to cargo pump-rooms below deck.

IMO interpretation

No circumstances can be foreseen where an Administration might allow any relaxation. (MSC/Circ.406/Rev.1)

17.7.3 The following IACS unified requirements are related to *IBC Code* paragraphs:

- **Cargo temperature control**

7.1.2 Heating or cooling media shall be of a type approved for use with the specific cargo. Consideration shall be given to the surface temperature of heating coils or ducts to avoid dangerous reactions from localized overheating or overcooling of cargo. (See also 15.13.6.)

On (...) chemical tankers, the maximum temperature of the heating media within the cargo area is to be adjusted to take into account the temperature class of the cargoes. (IACS UR F24)

17.8 Gas tankers – additional mark LIQUEFIED GAS TANKER

17.8.1 Gas tankers shall fulfil the requirements specified in PRS' *Rules for the Classification and Construction of Sea-going Gas Tankers*.

17.9 Oil spill response vessels – additional mark OIL RECOVERY VESSEL

17.9.1 Equipment and piping used for crude oil recovery and transfer shall be arranged outside machinery and accommodation spaces.

17.9.2 Where in vessels intended for the carriage of different cargoes, the fixed installation for crude oil recovery cannot be used for the cargo operations due to the nature of the cargoes, suitable shut-off arrangements shall be provided.

17.9.3 Where a vessel is provided with portable crude oil recovery unit then not more than two filling stub pipes connected with all tanks intended for the storage of the collected oil shall be

provided on the upper deck to connect the unit discharge pipes. The location of the stub pipes shall enable simultaneous connection of two recovery units operating on both sides of the vessel.

The pipes connecting filling stub pipes with storage tanks shall not be led through accommodation spaces situated on the open deck level. The possibility of leading such pipes through safe enclosed spaces, i.e. other than the hazardous spaces specified in *Part VIII*, 21.5.3.1 is subject to PRS acceptance in each particular case.

17.9.4 Inside diameter of sounding pipes of the spilled oil storage tanks shall not be less than 32 mm.

17.9.5 Exhaust gas lines of main and auxiliary engines, boilers, incinerators and galley stoves shall fulfil the requirements 6.1.3.

17.9.6 Outlets of exhaust gas lines of main and auxiliary engines, boilers, incinerators and galley stoves and other arrangements which contain source of ignition, as well as outlets of vent pipes of the engine crankcases shall be situated at least 6 m above the highest load waterline and in each case shall be outside the hazardous areas.

17.9.7 Ventilation systems serving hazardous spaces shall be independent of the ventilation systems serving safe spaces. Compartments of different hazard levels shall be provided with independent ventilation systems.

17.9.8 Safe spaces and air locks* shall be provided with mechanical supply ventilation maintaining an overpressure against the adjacent hazardous spaces.

* Air lock – enclosed gastight compartment, provided with two gastight, steel, self-closing doors separating safe space from dangerous space.

17.9.9 Provision shall be made for automatic starting the fans and for alarm in the case of loss of overpressure in the air lock. Alternatively, the following protective measures may be provided:

- .1 light signalling for each fan to indicate its operation;
- .2 an interlocking device to enable starting the fan only when the damper in ventilation duct is open;
- .3 an audible alarm indicating inadvertent switching-off the fan's motor.

17.9.10 Intakes of the supply ventilation and outlets of the exhaust ventilation shall be located on the open decks outside the hazardous spaces.

17.9.11 Compartments situated in the hazardous zones shall be provided with mechanical exhaust ventilation ensuring at least 20 air changes per hour. In such ventilation system, automatic switches may be fitted which change-over from 20 into 10 air changes per hour when the concentration of gases in the compartment does not exceed $(20 \pm 10)\%$ of the low explosion limit.

17.9.12 The exhaust ventilation ducts from hazardous compartments shall be gastight and shall have sufficient stiffness. Such ducts shall not be led through safe compartments.

17.9.13 Ventilation systems of compartments and air locks shall be fitted with arrangements monitoring the operation of equipment specified in 17.9.9 and 17.9.12.

17.9.14 The oil recovery operations and equipment manual (ORO Manual) containing a description of the safety precautions needed when preparing and carrying out oil recovery

operations shall be placed aboard the vessel for guidance of operating personnel. The manual shall be approved by PRS.

The manual shall include:

- .1 conditions and operational procedures to be followed when preparing and carrying out oil recovery operations;
- .2 storage oil tanks arrangement plan and venting system;
- .3 oil transfer diagram including pumps;
- .4 gas detection system;
- .5 plans showing the arrangement of the appliances and equipment used in oil recovery operations;
- .6 a list of appliances and equipment provided for oil recovery operations with instructions on their installation and operation;
- .7 ventilation system showing the spaces with overpressure ventilation and the arrangement of air locks;
- .8 measures for starting up the overpressure ventilation and gas detection systems;
- .9 a list of all electrical equipment to be disconnected when carrying out oil recovery operations.

17.10 Chemical spill response vessels – additional mark CHEMICAL RECOVERY VESSEL

The requirements specified in this subchapter apply to vessels which may with no restrictions be involved in a chemical spill response operation in hazardous atmosphere for the purposes of search, rescue and marine pollution tackling.

17.10.1 Technical documentation

17.10.1.1 In addition to the technical documentation specified in 1.3, the following additional documentation shall be submitted to PRS Head Office for consideration and approval:

- .1 cargo compartment bilge system plan,
- .2 arrangement plan of pressurized spaces and air locks*,

* Air lock – enclosed gastight compartment, provided with two gastight, steel, self-closing doors separating safe space from dangerous space.

- .3 ventilation plans of the citadel*, air locks, and cargo compartments,

* Citadel – an internal so called non-hazardous area which is protected against penetration by a hazardous atmosphere. The citadel comprises any space of the vessel which is in continuous use during service and for safety reasons must be accessible at all times.

- .4 arrangement plan of air filtering/regeneration arrangements including their characteristics.

17.10.2 Cargo compartment bilge system

17.10.2.1 Cargo compartment shall be provided with a separate bilge system for the disposal of potentially released hazardous substances.

17.10.3 Air and filling pipes

17.10.3.1 Engine crankcase venting systems shall be so arranged as to preclude the passage of hazardous substances into the crankcase.

17.10.3.2 Air and filling pipes of service tank shall be so arranged as to preclude the passage of hazardous substances into these tanks. Potable water tank air pipes shall terminate inside the citadel.

17.10.4 Exhaust gas system

17.10.4.1 Exhaust gas associated with internal combustion engines and boilers shall be provided with spark arresters approved by PRS.

17.10.4.2 Exhaust gas outlets to the open air shall not be situated in Zone 0 (for definitions of Zones – see *Part VIII*).

Exhaust gas outlets below the waterline are permitted on the following conditions:

- the maximum temperature of exhaust gas does not exceed 108°C and is being monitored in accordance with 17.10.4.4,
- other means such as water cooling or water injection have been provided to preclude the escape of sparks.

17.10.4.3 The temperature exhaust gas discharged to the open air in Zone 1 or Zone 2 shall not exceed 135°C.

17.10.4.4 The temperature of exhaust gas discharged to the open shall be monitored. If the maximum allowed temperature of exhaust gas is exceeded, alarm shall be given to the operating centre.

17.10.4.5 Exhaust gas lines shall be provided with flame arresters. If engines require to be started in a hazardous atmosphere, other means may be accepted to preclude the passage of gas-air mixtures or vapour-gas mixtures into the lines. Flame arresters shall be approved by PRS.

17.10.4.6 The number of detachable joints in exhaust gas lines shall be reduced to the practicable minimum.

17.10.5 Ventilation systems

17.10.5.1 Citadel and air locks shall be provided with overpressure supply ventilation.

17.10.5.2 Citadel ventilation system shall be so arranged that overpressure of at least 0.5 mbar in the entire volume of the citadel is maintained while the vessel is operating in a hazardous atmosphere.

17.10.5.3 For the purpose of ventilation and air-conditioning of the citadel during the operation of the vessel in a dangerous atmosphere, additional appropriate filtering devices should be used, taking air from the outside through filters or arrangements for air circulation and regeneration.

17.10.5.4 Air regeneration arrangements shall include a compressed air tank for the emergency air supply to the citadel.

17.10.5.5 The capacity of air filtering devices shall be such as to meet the air demand of the crew and personnel involved in the chemical spill response operation.

17.10.5.6 Air locks shall be so designed as to ensure the disposal of air containing any hazardous substances introduced in the locks as a result of their use. Not less than 20 air changes per hour of the total air lock volume shall be ensured.

17.10.5.7 Ventilation system of hazardous cargo compartment shall provide 30 air changes per hour. Electric motors shall not be located in the air flow.

17.10.6 Cooling water system

17.10.6.1 Cooling water systems shall be so arranged that during the ship operation in hazardous atmosphere the machinery and the associated installations be cooled without the sea water being taken in directly when the ship is operating in hazardous atmosphere, e.g. by means of box or skin cooling.

17.10.7 Additional requirements for the safe carriage of hazardous liquids

17.10.7.1 Chemical spill response vessels carrying hazardous liquids shall additionally fulfil the requirements of the *IBC Code* specified in:

- Chapter 3 – Ship Arrangements (subchapters: 3.3 – Cargo Pump-rooms, 3.5 – Bilge and Ballast Arrangements, 3.6 – Pump and Pipeline Identification, 3.7 – Bow or Stem Loading and Unloading Arrangements);
- Chapter 5 – Cargo Transfer;
- Chapter 8 – Cargo Tank Venting and Gas-freeing Arrangements;
- Chapter 12 – Mechanical Ventilation in Cargo Area;
- Chapter 15 – Special Requirements, subchapter 15.12 – Toxic Products.

17.11 Special purpose ships – additional marks: SPECIAL PURPOSE SHIP, CREW BOAT, RESEARCH SHIP, TRAINING SHIP

17.11.1 Special purpose ships of gross tonnage 500 and above carrying more than 12 persons, who are not crew members, shall fulfil the requirements specified in the *Code of Safety of Special Purpose Ships, 2008 (SPS Code)*. Ships to be assigned additional mark CREW BOAT, in lieu of compliance with *SPS Code*, shall comply with the applicable requirements of *Publication 12/P – Safety requirements for sea-going ships carrying industrial personnel*.

17.11.2 The bilge system in ships of up to 50 m in length and carrying up to 50 persons of special personnel shall fulfil the requirements specified in 1.8.2.2 and 1.8.2.3.

17.11.3 The bilge system in ships of above 50 m in length and carrying up to 50 persons of special personnel shall fulfil the requirements specified in 1.8.2.2, 1.8.2.3 and 17.1.3.3 as well as the following requirements:

- .1 In a compartment where strum box is located, a non-return valve shall be fitted in the bilge suction pipe if the pipe is led through other watertight compartments.
- .2 The valve boxes, cocks and valves in connection with the bilge system shall be so arranged that, in the event of flooding the compartment other than machinery space, one of the bilge pumps will be capable of draining any compartment. Furthermore any damage to a pump or a bilge pipe connected to the bilge main and located outside of the machinery space shall not put the bilge system out of operation. Valves in the bilge suction pipes from the compartments other than the machinery space shall be capable of being controlled from the machinery space or from places located above the bulkhead deck.

17.11.4 The bilge system in ships carrying more than 50 persons of special personnel shall fulfil the requirements specified in 1.8.2.2, 1.8.2.3, 17.1.3.2, 17.1.3.3, 17.1.3.6, 17.1.3.7, 17.1.3.11, 17.1.3.13, 17.1.3.14, 17.1.3.15.

17.11.5 The ventilation system in ships carrying more than 50 persons of special personnel shall also fulfil the requirements specified in 17.1.5.1.2, 15.1.5.2.1, 17.1.5.2.3 to 17.1.5.2.6.

17.12 Fishing vessels – additional mark FISHING VESSEL

17.12.1 Fishing vessels of 24 meters in length and more flying the flag of an EU Member State and registered in the community, or operating in the territorial waters or territorial sea of an EU Member State, or landing their catch in the port of an EU Member State shall comply in full with all the applicable requirements specified in *Publication 10/P – Safety requirements for sea-going fishing vessels*.

17.12.2 Fishing vessels of 24 meters in length and more other than those specified in 17.12.1 shall comply with the applicable requirements of the *Torremolinos International Convention for the Safety of Fishing Vessels 1977* and of the *Torremolinos Protocol* relating to the Convention specified in . in *Publication 10/P – Safety requirements for sea-going fishing vessels*.

17.12.3 Fishing vessels need not comply with the SOLAS requirements specified in this *Part VI*.

17.13 Offshore vessels – additional marks: TUG, SUPPLY VESSEL

17.13.1 The exhaust gas lines of main and auxiliary engines, boilers, incinerators and galley stoves of supply vessels and tugs serving oil tankers, chemical tankers, gas tankers, combination carriers, other ships carrying dangerous goods with the flash point below 60°C as well as ships intended for the carriage of timber shall fulfil the requirements specified in 10.1.3.

CHAPTER 18

18 ADDITIONAL REQUIREMENTS FOR SPECIFIC STRUCTURES, SYSTEMS OR EQUIPMENT

18.1 Ships using low-flashpoint gas fuels – additional marks: **IGF DF LNG, IGF DF CNG, IGF DF LPG, IGF DF H₂, LNG READY, CNG READY, LPG READY, H₂ READY, IGF LNG, IGF CNG, IGF LPG, IGF H₂, IGC DF**

18.1.1 Ships using low-flashpoint gas fuel, other than gas tankers using their cargo as fuel, receiving in their symbol of class **any of the above additional mark except IGC DF** shall comply with the requirements contained in *Publication 72/P – Safety requirements for ships using low-flashpoint gases as fuel*.

18.1.2 Gas tankers, using their cargo as fuel, receiving in their symbol of class additional mark **IGC DF** shall comply with the requirements of PRS' *Rules for the Classification and Construction of Sea-going Gas Tankers*, Chapter 16.

18.1.3 The requirements concerning safe bunkering of LNG on ships are contained in *Publication 116/P – Bunkering Guidelines for LNG as Marine Fuel*.

18.2 Ships operating in ice – additional marks of Baltic ice class: **L1A, L1, L2, L3 (L4); additional marks of Polar class: PC1, PC2, PC3, PC4, PC5, PC6, PC7**

18.2.1 Ships receiving in their symbol of class additional mark of Baltic ice class shall comply with the requirements contained in *Publication 122/P – Requirements for Baltic Ice Class Ships and Polar Class for Ships under PRS Supervision*, Part I, Chapter 7. These requirements are in line with the *Finnish-Swedish Ice Class Regulations* listed at website www.trafi.fi/en/maritime/ice_classes_of_ships.

18.2.2 Ships receiving in their symbol of class additional mark of Polar class shall comply with the requirements contained in *Polar Code*, Part I-A, Chapter 6 and Part II-A, Chapter 1 and 4 as well as in the *Publication 122/P – Requirements for Baltic Ice Class Ships and Polar Class for Ships under PRS Supervision*, Part II, Subchapters I3.7 to I3.10.

18.3 Periodically unattended machinery spaces – additional mark **AUT**

18.3.1 General

18.3.1.1 The arrangements provided shall be such as to ensure that the safety of the ship in all sailing conditions, including manoeuvring, is equivalent to that of a ship having the machinery spaces manned. (SOLAS, Reg. II-1/46.1)

18.3.1.2 Passenger ships shall be specially considered by the Administration as to whether or not their machinery spaces may be periodically unattended and if so whether additional requirements to those stipulated in these Regulations are necessary to achieve equivalent safety to that of normally attended machinery spaces. (SOLAS II-1/54)

18.3.2 Protection against flooding

18.3.2.1 Bilge wells in periodically unattended machinery spaces shall be located and monitored in such a way that the accumulation of liquids is detected at normal angles of trim and heel, and shall be large enough to accommodate easily the normal drainage during the unattended period. (SOLAS, Reg. II-1/48.1)

18.3.2.2 Where the bilge pumps are capable of being started automatically, means shall be provided to indicate when the influx of liquid is greater than the pump capacity or when the pump is operating more frequently than would normally be expected. In these cases, smaller bilge wells to cover a reasonable period of time may be permitted. Where automatically controlled bilge pumps are provided, special attention shall be given to oil pollution prevention requirements. (SOLAS, Reg. II-1/48.2)

18.3.2.3 The location of the controls of any valve serving a sea inlet, a discharge below the water-line or a bilge injection system shall be so sited as to allow adequate time for operation in case of influx of water to the space, having regard to the time likely to be required in order to reach and operate such controls. If the level to which the space could become flooded with the ship in the fully loaded condition so requires, arrangements shall be made to operate the controls from a position above such level. (SOLAS, Reg. II-1/48.3)

IACS and IMO interpretation

- (A) 'Bilge injection system' is same as 'direct suction' referred in 17.1.3.8 and 17.1.3.9 (SOLAS Reg. II-1/35-1 3.7.1 and 3.7.2) and is understood to mean 'Emergency bilge suction', which is used to discharge overboard large quantities of sea water accumulated in engine room bilges using the main circulating pump or another suitable pump as permitted by 17.1.3.9 (35-1 3.7.2).
- (B) The requirements for the controls of the "valves serving a sea inlet, a discharge below the waterline or a bilge injection system" are not applicable to valves serving an emergency bilge system provided:
- (1) The emergency bilge valve is normally maintained in a closed position,
 - (2) A non-return device is installed in the emergency bilge piping, and
- (Note: A normally closed non-return valve with positive means of closing is considered to satisfy both (1) and (2) above.)
- (3) The emergency bilge suction piping is located inboard of a shell valve that is fitted with the control arrangements required by 18.3.3 (SOLAS Reg. II-1/48.3). (IACS UI SC251, MSC.1/Circ.1424)

18.3.3 Means of control

18.3.3.1 For periodically unattended machinery spaces, the Administration shall give special consideration to (...) the location and centralization of the (...) required shutdown arrangements (e.g. ventilation, fuel pumps, etc.) (...). (SOLAS, Reg. II-2/5.2.3.1)

18.3.3.2 In passenger ships, these requirements (i.e. 18.3.3.1) shall be at least equivalent to those of machinery spaces normally attended. (SOLAS, Reg. II-2/5.2.3.2)

18.3.4 Oil fuel and lubricating oil systems

18.3.5 In addition to the requirements of paragraphs 2.1 to 2.4 (these paragraphs i.e. II-2/4.2.1 to II-2/4.2.4 can be found in various paragraphs in *Chapter 1, 5, 7, 8, 9 and 10*), the oil fuel and lubricating oil systems in a periodically unattended machinery space shall comply with the following:

- .1 where daily service oil fuel tanks are filled automatically, or by remote control, means shall be provided to prevent overflow spillages. Other equipment which treats flammable liquids automatically (e.g. oil fuel purifiers) which, whenever practicable, shall be installed in a special space reserved for purifiers and their heaters, shall have arrangements to prevent overflow spillages; and
- .2 where daily service oil fuel tanks or settling tanks are fitted with heating arrangements*, a high temperature alarm shall be provided if the flashpoint of the oil fuel can be exceeded. (SOLAS, Reg. II-2/4.2.5)

*** Note:**

Requirements for heating arrangements – see 8.4.4.

18.3.6 Starting air system

18.3.6.1 Means shall be provided to keep the starting air pressure at the required level where internal combustion engines are used for main propulsion. (SOLAS, Reg. II-1/53.5)

18.3.7 Safety systems for vessels with periodically unattended machinery spaces

IACS UR M30

18.3.7.1 Definition (M30.1)

The safety system is intended to operate automatically in case of faults endangering the plant so that:

- (i) normal operating conditions are restored (by starting of standby units), or
- (ii) the operation of the machinery is temporarily adjusted to the prevailing conditions (by reducing the output of machinery), or
- (iii) machinery and boilers are protected from critical conditions by stopping the machinery and shutting off the fuel to the boilers respectively (shutdown).

18.3.7.2 General requirements (M30.2)

18.3.7.2.1 Where a safety system is required by the Rules, the system is to comply with 18.3.7.2.2 – 18.3.7.2.8 (M30.2.2 - M30.2.8). (M30.2.1)

18.3.7.2.2 Operation of the safety system shall cause an alarm. (M30.2.2)

18.3.7.2.3 The safety system intended for the functions listed under M30.1 (iii) is to be independent of all other control and alarm systems so that failure or malfunction in these systems will not prevent the safety system from operating. For the safety systems intended for functions listed under 18.3.7.1 (i) and (ii) (M30.1(i) and (ii)), complete independence of other control and alarm systems is not required. (M30.2.3)

18.3.7.2.4 In order to avoid undesirable interruption in the operation of machinery, the system is to intervene sequentially after the operation of alarm system by:

Starting of standby units,
load reduction or shutdown, such that the least drastic action is taken first. (M30.2.4)

18.3.7.2.5 The system should be designed to 'fail safe'. The characteristics of 'fail safe' of a system is to be evaluated on the basis not only of the safety system itself and its associated machinery, but also on the inclusion of the whole machinery installation as well as the ship. (M30.2.5)

18.3.7.2.6 Safety systems of different units of the machinery plant are to be independent. Failure in the safety system of one part of the plant is not to interfere with the operation of the safety system in another part of the plant. (M30.2.6)

18.3.7.2.7 When the system has been activated, means are to be provided to trace the cause of the safety action. (M30.2.7)

18.3.7.2.8 When the system has stopped a unit, the unit is not to be restarted automatically before a manual reset has been carried out. (M30.2.8)

END OF IACS UR M30

18.4 Energy efficient ships – additional mark ECO EF

18.4.1 The requirements specified below apply to ships of gross tonnage 400 and above engaged on international voyages, specified in MARPOL Reg. VI/21, in accordance with the definitions contained in MARPOL Reg. VI/2.23 and VI/2.24.

18.4.2 The documents to be submitted at each stage of design are specified in *Publication 103/P – Guidelines on Ship Energy Efficiency*.

18.4.3 Prior to commencement and during the ship construction or modification, the documentation required at each stage of design, including the documentation prepared after the sea trials conducted, shall be submitted to PRS Head Office for consideration and approval.

SUPPLEMENT – RETROACTIVE REQUIREMENTS

1 GENERAL

1.1 The requirements specified in the present *Supplement* apply to existing ships, irrespective of their construction date, unless provided otherwise elsewhere in this *Supplement*.

1.2 Compliance with the applicable retroactive requirements is confirmed by PRS' Surveyor in the report on the nearest ship survey, to be carried out after the requirements compliance date.

2 REQUIREMENTS

2.1 Ballast water management systems (BWMS) on-board ships

Requirements of sub-chapter 4.5.4 apply to existing ships, where an application for approval for the plans of BWMS is made on or after 1 July 2022. (IACS UR M74, Rev.2, note 4)

ANNEX I – LIST OF EXTERNAL REFERENCE DOCUMENTS

IMO documents:

1. *International Convention for the Safety of Life at Sea, 1974 (SOLAS Convention)*
2. *International Convention for the Prevention of Pollution from Ships, 1973, as modified by the Protocol of 1978 relating thereto (MARPOL Convention)*
3. *International Convention on Load Lines, 1966, as amended by the 1988 Protocol (LL Convention)*
4. *International Convention for the Control and Management of Ships' Ballast Water and Sediments (BWM Convention)*
5. *Torremolinos International Convention for the Safety of Fishing Vessels 1977*
6. *Torremolinos Protocol relating to the Torremolinos International Convention for the Safety of Fishing Vessels 1977*
7. *Code for the Construction and Equipment of Ships Carrying Dangerous Chemicals in Bulk (BCH Code)*
8. *Code for Approval of Ballast Water Management Systems (BWMS Code)*
9. *International Code for the Construction and Equipment of Ships Carrying Dangerous Chemicals in Bulk (IBC Code)*
10. *International Code for the Construction and Equipment of Ships Carrying Liquefied Gases in Bulk (IGC Code)*
11. *International Code of Safety for Ships Using Gases or Other Low-flashpoint Fuels (IGF Code)*
12. *The International Maritime Dangerous Goods Code (IMDG Code)*
13. *The International Code for Intact Stability (IS Code)*
14. *International Code for the Application of Fire Test Procedures (FTP Code)*
15. *Technical Code on Control of Emission of Nitrogen Oxides from Marine Diesel Engines (NO_x Technical Code)*
16. *International Code for Ships Operating in Polar Waters (Polar Code)*
17. *Code of Safety for Special Purpose Ships (SPS Code)*

18. A.393(X) *Recommendation on international performance and test specifications for oily-water separating equipment and oil content meters*
19. A.446(XI) *Specifications for the design, operation and control of crude oil washing systems*
20. A.497(XII) *Amendments to the revised specifications for the design, operation and control of crude oil washing systems*
21. A.753(18) *Guidelines for the application of plastic pipes on ships*
22. A.897(21) *Amendments to the revised specifications for the design, operation and control of crude oil washing systems (resolution A.446 (XI) as amended by resolution A.497(XII))*

23. MSC/Circ.450/Rev.1 *Revised factors to be taken into consideration when designing cargo tank venting and gas-freeing arrangements*
24. MSC/Circ.474 *Guidelines for Bow and Stern Loading and Unloading. Arrangements on Oil Tankers*
25. MSC/Circ.647 *Guidelines to minimize leakages from flammable liquid systems*
26. MSC/Circ.677 *Revised standards for the design, testing and locating of devices to prevent the passage of flame into cargo tanks in tankers*
27. MSC/Circ.729 *Design guidelines and operational recommendations for ventilation systems in ro-ro cargo spaces*
28. MSC/Circ.731 *Revised factors to be taken into consideration when designing cargo tank venting and gas-freeing arrangements*
29. MSC/Circ.734 *Interpretations of Phrases on Human Performance Criteria in SOLAS Chapter II-1*
30. MSC/Circ.736 *Interpretations of vague expressions in SOLAS Chapter II-1*
31. MSC/Circ.834 *Guidelines for engine-room lay-out, design and arrangement*
32. MSC/Circ.851 *Guidelines on Engine Room Oil Fuel Systems*
33. MSC/Circ.1009 *Amendments to the revised standards for the design, testing and locating of devices to prevent the passage of flame into cargo tanks in tankers*
34. MSC/Circ.1034 *Guidelines for smoke control and ventilation systems for internal assembly stations and atriums on new passenger ships.*
35. MSC/Circ.1116 *Unified interpretations of the IBC and IGC Codes*
36. MSC/Circ.1120 *Unified interpretations of SOLAS Chapter II-2, the FSS Code, the FTP Code and related fire test procedures*
37. MSC/Circ.1515 *Revised design guidelines and operational recommendations for ventilation systems in ro-ro cargo spaces*
38. MSC.1/Circ.1203 *Unified interpretations of SOLAS Chapter II-2 and fire test procedures referred to in the FTP Code*
39. MSC.1/Circ.1212/Rev.1 *Revised guidelines on alternative design and arrangements for SOLAS Chapters II-1 and III*
40. MSC.1/Circ.1276 *Unified interpretations of SOLAS Chapter II-2*
41. MSC.1/Circ.1320 *Guidelines for the drainage of fire-fighting water from closed vehicle and ro-ro spaces and special category spaces for passenger and cargo ships*
42. MSC.1/Circ.1321 *Guidelines for measures to prevent fires in engine-rooms and cargo pump-rooms*
43. MSC.1/Circ.1322 *Unified interpretations of SOLAS Chapter II-2*

44. MSC.1/Circ.1324 *Amendments to the revised standards for the design, testing and location of devices to prevent the passage of flame into cargo tanks in tankers (MSC/Circ.677, as amended by MSC/Circ.1009)*
45. MSC.1/Circ.1362/Rev.2 *Unified interpretation of SOLAS Chapter II-1*
46. MSC.1/Circ.1424/Rev.1 *Unified interpretation of SOLAS regulation II-1/48.3*
47. MSC.1/Circ.1426/Rev.1 *Unified interpretations of SOLAS regulation II-1/3-5*
48. MSC.1/Circ.1434 *Unified interpretations of SOLAS Chapter II-2*
49. MSC.1/Circ.1436 *Amendments to the unified interpretations of SOLAS Chapter II-2, the FSS Code, the FTP Code and related fire test procedures (MSC/Circ.1120)*
50. MSC.1/Circ.1455 *Guidelines for the approval of alternatives and equivalents as provided for in various IMO instruments*
51. MSC.1/Circ.1464/Rev.1/Corr.2 *Unified interpretations of SOLAS Chapters II-1 and XII, of the technical provisions for means of access for inspections (resolution MSC.158(78)) and of the performance standards for water level detectors on bulk carriers and single hold cargo ships other than bulk carriers (resolution MSC.188(79))*
52. MSC.1/Circ.1467 *Unified interpretation of SOLAS regulation II-1/26.3*
53. MSC.1/Circ.1510 *Amendment to the unified interpretations of SOLAS Chapter II-2, the FSS Code, the FTP Code and related fire test procedures (MSC/Circ.1120)*
54. MSC.1/Circ.1514 *Performance standard, functional requirements and system requirements for the assessment of smoke management systems*
55. MSC.1/Circ.1515 *Revised design guidelines and operational recommendations for ventilation systems in ro-ro cargo spaces*
56. MSC.1/Circ.1527 *Unified interpretations of SOLAS Chapter II-2*
57. MSC.1/Circ.1555 *Unified interpretations of SOLAS Chapter II-2*
58. MSC.1/Circ.1559 *Unified interpretation of the IGC Code*
59. MSC.1/Circ.1572/Rev.1 *Unified interpretations of SOLAS Chapters II-1 and XII, of the technical provisions for means of access for inspections (resolution MSC.158(78)) and of the performance standards for water level detectors on bulk carriers and single hold cargo ships other than bulk carriers (resolution MSC.188(79))*
60. MSC.1/Circ.1574 *Interim guidelines for use of fibre reinforced plastic (FRP) elements within ship structures: Fire safety issues*
61. MSC.1/Circ.1606 *Unified interpretations of the IGC Code*
62. MSC.1/Circ.1625 *Unified interpretations of the IGC Code*
63. MSC.1/Circ.1655 *Unified interpretations of SOLAS Chapter II-2*
64. MSC.188(79) *Performance standards for water level detectors on bulk carriers and single hold cargo ships other than bulk carriers*
65. MSC.216(82) *Amendments to the International Convention for the Safety of Life at Sea, 1974, as amended*
66. MSC.307(88) *International Code for Application of Fire Test Procedures, 2010 (2010 FTP Code)*
67. MSC.313(88) *Amendments to the guidelines for the application of plastic pipes on ships (resolution A.753(18))*
68. MSC.362(92) *Revised recommendation on a standard method for evaluating cross-flooding arrangements*
69. MSC.370(93) *Amendments to The International Code for The Construction and Equipment of Ships Carrying Liquefied Gases In Bulk (IGC Code)*
70. MSC.375(93) *Amendments to the Protocol of 1988 relating to the International Convention On Load Lines, 1966, as amended*
71. MSC.391(95) *Adoption of the International Code of Safety for Ships Using Gases or Other Low-Flashpoint Fuels (IGF Code)*
72. MSC.399(95) *Amendments to the guidelines for the application of plastic pipes on ships (resolution A.753(18)), as amended by resolution MSC.313(88)*
73. MSC.421(98) *Amendments to the International Convention for the Safety of Life at Sea, 1974, as amended*
74. MSC.428(98) Rev.1, Rev.2 *Revised explanatory notes to the SOLAS Chapter II-1 Subdivision and Damage Regulations*
75. MSC.436(99) *Amendments to the International Convention for the Safety of Life at Sea, 1974, as amended*
76. MSC.437(99) *Amendments to the International Code for Application of Fire Test Procedures, 2010 (2010 FTP Code)*
77. MSC.474(102) *Amendments to the International Convention for the Safety of Life at Sea, 1974*
78. MSC.491(104) *Amendments to the Protocol of 1988 Relating to the International Convention on Load Lines, 1966 (1988 Load Lines Protocol)*
79. MEPC 52/24/Add.1 *Report of the Marine Environment Protection Committee on its fifty-second session*
80. MEPC.2(VI) *Recommendation on International Effluent Standards and Guidelines for Performance Tests for Sewage Treatment Plants*
81. MEPC.3(XII) *Standard Format of the Crude Oil Washing Operation and Equipment Manual*
82. MEPC.5(XIII) *Specifications for Oil/Water Interface Detectors*
83. MEPC.60(33) *Guidelines and specifications for pollution prevention equipment for machinery space bilges of ships*
84. MEPC.81(43) *Amendments to Section 9 of the Standard Format for the COW Manual (resolution MEPC.3(XII))*

85. MEPC.107(49) *Revised guidelines and specifications for pollution prevention equipment for machinery space bilges of ships*
86. MEPC.108(49) *Revised Guidelines and Specifications for Oil Discharge Monitoring and Control Systems for Oil Tankers*
87. MEPC.149(55) *Guidelines for ballast water exchange design and construction standards (G11)*
88. MEPC.159(55) *Revised Guidelines on Implementation of Effluent Standards and Performance Tests for Sewage Treatment Plants*
89. MEPC.169(57) *Guidelines for Approval of Ballast Water Management Systems that make use of active substances (G9)*
90. MEPC.182(59) *Guidelines for the sampling of fuel oil for determination of compliance with the revised MARPOL Annex VI*
91. MEPC.183(59) *2009 Guidelines for monitoring the worldwide average sulphur content of residual fuel oils supplied for use on board ships*
92. MEPC.205(62) *2011 Guidelines and specifications for add-on equipment for upgrading resolution MEPC.60(33)-compliant oil filtering equipment*
93. MEPC.207(62) *2011 Guidelines for the control and management of ships' biofouling to minimize the transfer of invasive aquatic species*
94. MEPC.209(63) *2012 Guidelines on design and construction to facilitate sediment control on ships (G12)*
95. MEPC.227(64) *2012 Guidelines on implementation of effluent standards and performance tests for sewage treatment plants*
96. MEPC.240(65) *2013 Amendments to the Revised Guidelines and Specifications for Oil Discharge Monitoring and Control Systems for Oil Tankers (Resolution MEPC.108(49))*
97. MEPC.274(69) *Amendments to the annex of the International Convention for the Prevention of Pollution from Ships, 1973, as modified by the protocol of 1978 relating thereto – Amendments to MARPOL Annex IV*
98. MEPC.285(70) *Amendments to the revised guidelines and specifications for pollution prevention equipment for machinery space bilges of ships (resolution MEPC.107(49))*
99. MEPC.300(72) *Code for Approval of Ballast Water Management Systems (BWMS Code)*
100. MEPC.314(77) *Amendments to the Annex of the International Convention for the Prevention of Pollution from Ships, 1973, as Modified by the Protocol of 1978 relating thereto. Amendments to MARPOL Annex II (Cargo residues and tank washings of persistent floating products)*
101. MEPC.1/Circ.642 *2008 Revised Guidelines for Systems for Handling Oily Wastes in Machinery Spaces of Ships Incorporating Guidance Notes for an Integrated Bilge Water Treatment System (IBTS)*
102. MEPC.1/Circ.676 *Amendment to the 2008 Revised Guidelines for Systems for Handling Oily Wastes in Machinery Spaces of Ships Incorporating Guidance Notes for an Integrated Bilge Water Treatment System (IBTS)*
103. MEPC.1/Circ.760 *Amendments to the 2008 Revised Guidelines for Systems for Handling Oily Wastes in Machinery Spaces of Ships Incorporating Guidance Notes for an Integrated Bilge Water Treatment System (IBTS) (MEPC.1/Circ.642, as Amended by MEPC.1/Circ.676)*
104. MEPC.1/Circ.864/Rev.1 *Guidelines for onboard sampling for the verification of the sulphur content of the fuel oil used on board ships*
105. MEPC.1/Circ.867 *Unified interpretations of regulations 1.24, 12, 27 and 28.3.3 of MARPOL Annex I*
106. BWM.2/Circ.20 *Guidance to ensure safe handling and storage of chemicals and preparations used to treat ballast water and the development of safety procedures for risks to the ship and crew resulting from the treatment process*

IACS Resolutions:

1. PR29 Rev.0 *Definition of date of “contract for construction”*
2. UI CC1 Rev.2 *Interpretation of sub-section 3.9(b), BCH Code*
3. UI CC4 *Venting System on Chemical Tankers*
4. UI CC6 Rev.1 *Lining approved for use with acids – IBC Code item 15.11.2*
5. UI GC9 Rev.1 *Guidance for sizing pressure relief systems for interbarrier spaces*
6. UI GC15 Rev.1 *Closing Devices for Air Intakes*
7. UI GC19 *External surface area of the tank for determining sizing of pressure relief valves (paragraph 8.4.1.2 and figure 8.1)*
8. UI GC23 Corr.1 *Cargo tank structure heating arrangement power supply*
9. UI GC24 Rev.1 *Fire Test for Emergency Shutdown Valves*
10. UI GC25 Rev.1 Corr.1 *Cargo piping insulation*
11. UI GC26 Corr.1 *Type testing requirements for valves*
12. UI GC27 Corr.1 *Level indicators for cargo tanks*

13. UI GC28 Rev.1 Corr.1 *Guidance for sizing pressure relief systems for interbarrier spaces*
14. UI GC32 Rev.1 *Outer Duct in Gas Fuel Piping Systems*
15. UI GC33 *Cargo sampling*
16. UI GC34 *Cargo filters*
17. UI GC35 *Inhibition of Cargo Pump Operation and Opening of Manifold ESD valves with Level Alarms Overridden*
18. **UI LL11 Rev.4 *Scuppers, inlets and discharges***
19. UI LL36 Rev.2 *Minimum wall thickness of pipes (Regulations 19, 20 and 22)*
20. UI LL49 Rev.1 *Air pipe closing devices (Regulation 20)*
21. UI MPC2 Rev.1 *Operational manuals for oil discharge monitoring and control systems (Annex I, Regulation 31.4)*
22. UI MPC85 Rev.4 *Regulation 22(5), Annex I of MARPOL 73/78 as amended by resolution MEPC.117(52)*
23. UI MPC86 Corr.1 *Annex IV of MARPOL 73/78 Regulation 10(1) as amended by resolution MEPC.115(51)*
24. UI SC16 Rev.2 *Definitions (Reg. II-2/3.34)*
25. UI SC17 Rev.3 *Definitions - Control Stations (SOLAS Reg. II-2/3.18)*
26. UI SC39 Rev.2 *Ventilation systems in ships other than passenger ships carrying more than 36 passengers (Reg. II-2/8.2)*
27. UI SC57 Rev.2 *Venting, purging, gas freeing and ventilation (Reg. II-2//4.5.3.4.1.3 and 4.5.3.4.1.4)*
28. UI SC58 Rev.2 *Venting, purging, gas freeing and ventilation (Reg. II-2/4.5.6.3)*
29. UI SC64 Rev.2 *Fire dampers in ventilation ducts (Reg. II-2/9.7.3.1)*
30. UI SC75 Rev.1 *Fire protection arrangements in cargo spaces (Reg. II-2/20.3.1.3)*
31. UI SC81 Rev.1 *Drainage of enclosed spaces situated on the bulkhead deck (Chapter II-1, Regulation 35-1.2.6.1, Res. MSC.194(80))*
32. UI SC100 Rev.2 Corr.1 *Closing appliances of ventilation inlets and outlets (Reg. II-2/5.2.1.1)*
33. UI SC102 Rev.1 *Cold Service (Reg. II-2/5.3.1.1)*
34. UI SC123 **Rev.5** Corr.1 *Machinery Installations - Service Tank Arrangements (Reg. II-1/26.11)*
35. UI SC140 Rev.3 *Secondary Means of Venting Cargo Tanks Reg. II-2/4.5.3.2.2*
36. UI SC148 Rev.2 *Ventilation by fan coil units and internal circulation fans (Reg. II-2/5.2.1.2, II-2/5.2.1.2 and Reg. II-2/7.9.3)*
37. UI SC179 Rev.3 *Dewatering of forward spaces of bulk carriers (Resolution MSC.188(79))*
38. UI SC184 Rev.1 *Machinery Installations – Dead Ship Condition (SOLAS Regulation II-1/26.4)*
39. UI SC185 Rev.1 *Starting Arrangements for Emergency Generating Sets (SOLAS Regulation II-1/44, paragraph 1)*
40. UI SC214 *Portions of open decks utilized for the storage of gas bottles (Regulation II-2/4.3 Arrangements for gaseous fuel for domestic purposes)*
41. UI SC232 *Steam Boilers and Boiler Feed Systems (SOLAS Reg. II-1/32.4)*
42. UI SC240 Corr.1 *Closing device for ventilation of battery rooms (SOLAS II-2/5.2.1.1)*
43. UI SC243 Rev.1 *Access to controls for closing of ventilation of vehicle, special category and ro-ro spaces (SOLAS II-2/20.3.1.4.1)*
44. UI SC249 Rev.1 *Implementation of SOLAS II-1, Regulation 3-5 and MSC.1/Circ.1379*
45. UI SC 251 *Controls of emergency bilge suction valve in periodically unattended machinery spaces (SOLAS regulations II-1/48.3)*
46. UI SC255 Corr.1 *Fuel pump arrangement required for ships to maintain normal operation of propulsion machinery when operating in emission control areas and non-restricted areas SOLAS II-1 26-3. (Partially)*
47. UI SC264 **Corr.1** *Non-combustible material as 'steel or equivalent' for ventilation ducts (SOLAS II-2, Reg. 9.7.1.1)*
48. UI SC274 Rev.1 *Hazardous area classification in respect of selection of electrical equipment, cables and wiring and positioning of openings and air intakes*
49. **UI SC299 *Watertight testing after fire testing of penetrations in watertight divisions in passenger ships***
50. **UI SC300 *Containment of fire: details of fire insulation of duct penetrations***
51. UR E18 Rev.1 *Recording of the type, location and maintenance cycle of batteries*
52. UR F8 Rev.1 *Pressurisation of cargo tanks*
53. UR F13 Rev.1 *Gland seals in pump room bulkheads*
54. UR F15 Rev.6 Corr.1 *Reinforced thickness of ballast and cargo oil piping*
55. UR F16 Rev.1 *Bow and stern loading and unloading arrangements on oil tankers*
56. UR F21 *Pump room ventilation*
57. UR F24 Rev.2 *Temperature of Steam and Heating Media within the Cargo Area*
58. UR F35 Rev.8 *Fire protection of machinery spaces*
59. UR F44 Rev.2 *Forepeak ballast system on oil tankers*
60. UR G3 Rev.7 *Liquified gas cargo and process piping*
61. UR M11 *Protective devices for starting air mains*
62. UR M24 Rev.1 *Requirements concerning use of crude oil or slops as fuel for tanker boilers*
63. UR M26 Corr.1 *Safety devices of steam turbines*
64. UR M30 Rev.1 *Safety systems for vessels with periodically unattended machinery spaces*

65. UR M35 Rev.8 *Alarms, remote indications and safeguards for main reciprocating internal combustion engines installed in unattended machinery spaces*
66. UR M61 Rev.1 *Starting arrangements of internal combustion engines*
67. UR M65 Rev.1 *Draining and Pumping Forward Spaces in Bulk Carriers*
68. UR M74 Rev.2 *Installation of Ballast Water Management Systems*
69. UR M75 Rev.1 *Ventilation of emergency generator rooms*
70. UR M77 Rev.4 *Storage and use of SCR reductants*
71. UR M81 **Rev.1** *Safety measures against chemical treatment fluids used for exhaust gas cleaning systems and the residues which have hazardous properties*
72. UR P1 Rev.5 *Rules for pipes*
73. UR P2 Rev.10 *Rules for piping design, construction and testing*
74. UR P3 Rev.5 *Air pipe closing devices*
75. UR P4 Rev.6 *Production and Application of Plastic Piping Systems on Ships*
76. UR S2 Rev.2 *Definition of Ship's Length L and of Block Coefficient C_b*
77. UR S27 Rev.6 *Strength Requirements for Fore Deck Fittings and Equipment*
78. UR W1 Rev.4 *Material and welding for ships carrying liquified gases in bulk and ships using gases or other low-flashpoint fuels*
79. UR Z26 *Alternative Certification Scheme (ACS)*

80. REC. 58 Rev.2 *Fire Protection of Machinery Spaces*
81. REC. 86 Rev.2 *Applicable Standards for UR P4.7 "Requirements for Type Approval of Plastic Pipes"*
82. REC. 132 *Human Element Recommendations for structural design of lighting, ventilation, vibration, noise, access and egress arrangements*
83. REC. 146 *Risk assessment as required by the IGF Code*
84. REC. 151 **Rev.2** *Recommendation for fuel oil treatment systems*

ASTM standards:

1. ASTM C581 *Standard Practice for Determining Chemical Resistance of Thermosetting Resins Used in Glass-Fiber-Reinforced Structures Intended for Liquid Service*
2. ASTM D257 *Standard Test Methods for DC Resistance or Conductance of Insulating Materials*
3. ASTM D635-18 *Standard Test Method for Rate of Burning and/or Extent and Time of Burning of Plastics in a Horizontal Position*
4. ASTM D648-18 *Standard Test Method for Deflection Temperature of Plastics Under Flexural Load in the Edgewise Position*
5. ASTM D1598 *Standard Test Method for Time-to-Failure of Plastic Pipe Under Constant Internal Pressure*
6. ASTM D1599 *Standard Test Method for Resistance to Short-Time Hydraulic Pressure of Plastic Pipe, Tubing, and Fittings*
7. ASTM D2837 *Standard Test Method for Obtaining Hydrostatic Design Basis for Thermoplastic Pipe Materials or Pressure Design Basis for Thermoplastic Pipe Products*
8. ASTM D2992 *Standard Practice for Obtaining Hydrostatic or Pressure Design Basis for "Fiberglass" (Glass-Fiber-Reinforced Thermosetting-Resin) Pipe and Fittings*
9. ASTM D2412 *Standard Test Method for Determination of External Loading Characteristics of Plastic Pipe by Parallel-Plate Loading*
10. ASTM D2444 *Standard Practice for Determination of the Impact Resistance of Thermoplastic Pipe and Fittings by Means of a Tup (Falling Weight)*
11. ASTM F1173 *Standard Specification for Thermosetting Resin Fiberglass Pipe Systems to Be Used for Marine Applications*

ISO standards:

1. ISO 75-2:2013 *Plastics – Determination of temperature of deflection under load – Part 2: Plastics and ebonite*
2. ISO 306 *Plastics – Thermoplastic materials – Determination of Vicat softening temperature (VST)*
3. ISO 1182:2010 *Reaction to fire tests for products – Non-combustibility test*
4. ISO 1716 *Reaction to fire tests for products – Determination of the gross heat of combustion (calorific value)*
5. ISO 2507 *Thermoplastics pipes and fittings – Vicat softening temperature*
6. ISO 3170:2004 *Petroleum liquids – Manual sampling*
7. ISO 3171:1988 *Petroleum liquids – Automatic pipeline sampling*
8. ISO 6802:2018 *Rubber or plastics hoses and hose assemblies – Hydraulic impulse test with flexing*

9. ISO 6803:2017 *Rubber or plastics hoses and hose assemblies – Hydraulic-pressure impulse test without flexing*
10. ISO 8217:2017 *Petroleum products – Fuels (class F) – Specifications of marine fuels*
11. ISO 8361 *Thermoplastics pipes and fittings – Water absorption*
12. ISO 9001:2015 *Quality management systems – Requirements*
13. ISO 9142 *Adhesives – Guide to the selection of standard laboratory ageing conditions for testing bonded joints*
14. ISO 9653 *Adhesives – Test method for shear impact strength of adhesive bonds*
15. ISO 9854 *Thermoplastics pipes for the transport of fluids*
16. ISO 10380:2012 *Pipework – Corrugated metal hoses and hose assemblies*
17. ISO 10816 series *Mechanical vibration – Evaluation of machine vibration by measurements on non-rotating parts*
18. ISO 12156-1 *Diesel fuel – Assessment of lubricity using the high-frequency reciprocating rig (HFRR) – Part 1: Test method*
19. ISO 13739 *Petroleum products – Procedures for the transfer of bunkers to vessels*
20. ISO 15493 *Plastics piping systems for industrial applications – Acrylonitrile-butadiene-styrene (ABS), unplasticized poly(vinyl chloride) (PVC-U) and chlorinated poly(vinyl chloride) (PVC-C) – Specifications for components and the system – Metric series*
21. ISO 15540:2016 *Ships and marine technology – Fire resistance of non-metallic hose assemblies and non-metallic compensators – Test methods*
22. ISO 15541:2016 *Ships and marine technology – Fire resistance of non-metallic hose assemblies and non-metallic compensators – Requirements for the test bench*
23. ISO 18611-1:2014 *Ships and marine technology – Marine NO_x reduction agent AUS 40 – Part 1: Quality requirements*
24. ISO 18611-3:2014 *Ships and marine technology – Marine NO_x reduction agent AUS 40 – Part 3: Handling, transport and storage*
25. ISO 19921:2005 *Ships and marine technology – Fire resistance of metallic pipe components with resilient and elastomeric seals – Test methods*
26. ISO 19922:2005 *Ships and marine technology – Fire resistance of metallic pipe components with resilient and elastomeric seals – Requirements imposed on the test bench*
27. ISO 20816-1 *Mechanical vibration – Measurement and evaluation of machine vibration – Part 1: General guidelines*
28. ISO 31010 – *Risk Assessment Techniques*
29. ISO Recommendations R336 *Iron and steel pipes*

Other standards:

1. IEC 60092-502: 1999 *Electrical installations in ships – Tankers – Special features*
2. NS 6126 *Plastic pipes – Glass fibre reinforced polyester (GRP) pipes and fittings – Technical delivery requirements – For marine use*
3. PN-W-74017 *Ship's fittings – Requirements and testing*
4. PN EN 12266-1 *Industrial valves – Testing of valves – Part 1: Pressure tests, test procedures and acceptance criteria. Mandatory requirements*

EU legal documents:

1. Commission Implementing Regulation (EU) 2022/1157 of 4 July 2022 *laying down rules for the application of Directive 2014/90/EU of the European Parliament and of the Council, as regards design, construction and performance requirements and testing standards for marine equipment and repealing Implementing Regulation (EU) 2021/1158*
2. Directive 2014/90/EU of the European Parliament and of the Council of 23 July 2014 *on marine equipment and repealing Council Directive 96/98/EC*

Other legal documents:

1. *Finnish-Swedish Ice Class Regulations*

List of amendments as of 1 January 2024

<i>Item</i>	<i>Title/Subject</i>	<i>Source</i>
17.12 (entire)	Amendments due to the introduction of new Publication 10/P	PRS
1.8.2.2, 1.8.2.3	Peak and machinery space bulkheads (amendments to SOLAS)	MSC.474(102)
17.1.1 (entire)	Openings in watertight boundaries (amendments to SOLAS)	MSC.474(102)
1.8.4.10, 11	Items 1.8.4.10 and 1.4.8.11 deleted (amendments to SOLAS)	MSC.474(102)
1.8.5.1	Watertight closures (amendments to SOLAS)	MSC.474(102)
17.1.2	Internal watertight integrity (amendments to SOLAS)	MSC.474(102)
6.4.1	Storage and the use of SCR reductants (new revision)	UR M77 Rev.4
2.2.8	Scuppers and discharges (amendments to LL Protocol)	MSC.491(104)
17.1.1.4	Penetrations in watertight boundaries in passenger ships (UI of SOLAS)	MSC.1/Circ.1362 Rev.2

List of amendments as of 1 July 2024

<i>Item</i>	<i>Title/Subject</i>	<i>Source</i>
7.2.1	Non-combustible material as 'steel or equivalent' for ventilation ducts	UI SC264
8.2.11	Machinery Installations – Service Tank Arrangements	UI SC123
6.5.2.3, 6.5.2.4, 6.5.2.10, 6.5.3, 6.5.4	Safety measures against chemical treatment fluids used for exhaust gas cleaning systems and the residues which have hazardous properties	UR M81
1.6.12.3.5, Annex I	IACS has deleted UR F42. Consequently Note in 1.6.12.3.5 has been deleted, and the UR itself has been deleted from Annex I – List of external reference documents	UR F42
17.1.1.4	Watertight testing after fire testing of penetrations in watertight divisions in passenger ships	UI SC299
7.4.1.2, 7.4.2	Containment of fire: details of fire insulation of duct penetrations	UI SC300
8.10 (many subparagraphs)	Recommendation for fuel oil treatment systems	REC. 151
8.11.2, 18.1, 18.1.1	Change of Publication 72/P title and content	PRS
Page 2	New Publication 12/P added to the list	PRS
17.1.1	Amended provision concerning Crew Boats	PRS
2.2.2	Scuppers, inlets and discharges	UI LL11