



RULES

PUBLICATION 63/P

REPLACEMENT CRITERIA FOR SIDE SHELL FRAMES AND BRACKETS IN SINGLE SIDE SKIN BULK CARRIERS AND OIL-BULK-ORE CARRIERS

July
2008

Publications P (Additional Rule Requirements) issued by Polski Rejestr Statków complete or extend the Rules and are mandatory where applicable.

GDAŃSK

Publication No. 63/P – Replacement Criteria for Side Shell Frames and Brackets in Single Side Skin Bulk Carriers and Oil-Bulk-Ore Carriers – July 2008, is an extension of the requirements contained in Part I – Classification Regulations, of the Rules for the Classification and Construction of Sea-going Ships.

This Publication was approved by PRS Executive Board on 6 May 2008 and enters into force on 1 July 2008.

© Copyright by Polish Register of Shipping*, 2008

* *Polish Register of Shipping means Polski Rejestr Statków S.A., seated in Gdańsk, al. gen. Józefa Hallera 126, 80-416 Gdańsk, Poland, registered in the Register of Entrepreneurs of the National Court Register, under entry number 0000019880. Polish Register of Shipping, its affiliates and subsidiaries, their respective officers, employees or agents are, individually and collectively, referred to as Polish Register of Shipping or as PRS for short.*

CONTENTS

	Page
1 Application and Definitions	5
1.1 Ice Strengthened Ships.....	6
2 Renewal or other Measures	6
2.1 Criteria for Renewal or Other Measures	6
2.2 Thickness Measurements, Steel Renewal, Sand Blasting, Coating and Repair of Damaged Frames	8
2.3 Reinforcing Measures.....	10
2.4 Weld Throat Thickness.....	10
2.5 Pitting and Grooving	10
2.6 Renewal of All Frames in One or More Cargo Holds.....	10
2.7 Renewal of Damaged Frames.....	10
3 Strength Check Criteria	11
3.1 Load Model.....	11
3.2 Allowable Stresses	13
3.3 Shear Strength Check.....	13
3.4 Bending Strength Check	13

1 APPLICATION AND DEFINITIONS

The requirements specified in this *Publication* apply to the side shell frames and brackets of cargo holds bounded by the single side shell of bulk carriers constructed with single deck, topside tanks and hopper tanks in cargo spaces intended primarily to carry dry cargo in bulk, which were not built in accordance with sub-chapter 20.5 of *Part II – Hull* of the *Rules for Classification and Construction of Sea-going Ships*, (hereinafter referred to as the *Rules*)*.

These requirements also apply to the side shell frames and brackets of cargo holds bounded by the single side shell of oil-bulk-ore (OBO) carriers constructed with single deck.

In the case a vessel as defined above does not satisfy above definition in one or more holds (or some parts of the holds), the requirements in this *Publication* do not apply to these individual holds.

For the purpose of the *Publication* the term “ship” means both “bulk carrier” and “OBO carrier” unless otherwise specified in particular provisions.

Bulk carriers that are subject to these requirements shall be assessed for compliance with the requirements given below and steel renewal, reinforcement or coating, where required, shall be performed in accordance with the following schedule and at subsequent intermediate and special surveys:

- a) for bulk carriers which were 15 years of age or more on 1 January 2005, by the due date of the first intermediate or special survey after that date;
- b) for bulk carriers which were 10 years of age or more on 1 January 2005, by the due date of the first special survey after that date;
- c) for bulk carriers which were less than 10 years of age on 1 January 2005, by the date on which the ship reaches 10 years of age.

Completion prior to 1 January 2005 of an intermediate or special survey with a due date after 1 January 2005 cannot be used to postpone compliance.

However, completion prior to 1 January 2005 of an intermediate survey the window for which straddles 1 January 2005 can be accepted.

OBO carriers that are subject to these requirements shall be assessed for compliance with the requirements specified below and steel renewal, reinforcement or coating, where required shall be performed in accordance with the following schedule and at subsequent intermediate and special surveys:

- a) For OBO carriers which were 15 years of age or more on 1 July 2005, by the due date of the first intermediate or special survey after 1 July 2005;
- b) For OBO carriers which were 10 years of age or more on 1 July 2005, by the due date of the nearest special survey after 1 July 2005;
- c) For OBO carriers which were less than 10 years of age on 1 July 2005, by the date on which the ship reaches 10 years of age.

Completion prior to 1 January 2005 of an intermediate or special survey with a due date after 1 January 2005 cannot be used to postpone compliance.

However, completion prior to 1 January 2005 of an intermediate survey the window for which straddles 1 January 2005 can be accepted.

* Requirements of sub-chapter 20.5 of *PRS Rules for Classification and Construction of Sea-going Ships, Part II – Hull* cover the requirements of *UR S12 IACS*.

These requirements define steel renewal criteria or other measures to be taken for the webs and flanges of side shell frames and brackets as per Chapter 2.

Reinforcing measures of side frames are also specified in sub-chapter 2.3.

Finite element or other numerical analysis or direct calculation procedures cannot be used as an alternative to compliance with the requirements of this *Publication*, except in cases of unusual side structure arrangements or framing to which the requirements specified in this *Publication* cannot be directly applied. In that case, the analysis criteria and the strength check criteria shall be in accordance with *Part II – Hull of the Rules*.

1.1 Ice Strengthened Ships

1.1.1 Where bulk carriers are reinforced to comply with an ice class notation, intermediate frames shall not be included when considering compliance with this *Publication*.

1.1.2 Renewal thicknesses for the additional structure required to meet the ice strengthening notation are specified by PRS in each particular case.

1.1.3 If the ice class notation is requested to be withdrawn, the additional ice strengthening structure, with the exception of tripping brackets (see 2.1.2.1b and 2.3), shall not be considered to contribute to compliance with this *Publication*.

2 Renewal or Other Measures

2.1 Criteria for Renewal or Other Measures

2.1.1 Symbols Used in Sub-chapter 2.1

- t_M – thickness as measured, [mm],
- t_{REN} – thickness at which renewal is required. See sub-chapter 2.1.2,
- $t_{REN,d/t}$ – thickness criteria based on d/t ratio. See sub-chapter 2.1.2.1,
- $t_{REN,S}$ – thickness criteria based on strength. See sub-chapter 2.1.2.2,
- $t_{COAT} = 0.75 t_{20.5}$,
- $t_{20.5}$ – thickness in mm as required by sub-chapter 20.5 of *Part II of the Rules*, in 20.5.3 for frame webs and in 20.5.4 for upper and lower brackets webs,
- t_{AB} – thickness as built, in mm,
- t_C – see Table 2.1.1 below.

Table 2.1.1 – t_C values, [mm]

Ship's length L , in m	Holds other than No. 1		Hold No. 1	
	Span and upper brackets	Lower brackets	Span and upper brackets	Lower brackets
100	2.0	2.5	2.0	3.0
150	2.0	3.0	3.0	3.5
200	2.0	3.0	3.0	4.0

Note: For intermediate ship lengths, t_C is obtained by linear interpolation between the above values.

2.1.2 Criteria for Webs (Shear and other Checks)

Webs of side shell frames and brackets shall be renewed when the measured thickness (t_M) is equal to or less than the thickness (t_{REN}) as defined below:

t_{REN} is the greatest of:

- (a) $t_{COAT} - t_C$
- (b) $0.75t_{AB}$
- (c) $t_{REN,d/t}$ (applicable to zone A and B only – see Fig. 1)
- (d) $t_{REN,S}$ (where required in sub-chapter 2.1.2.2)

2.1.2.1 Thickness Criteria Based on d/t Ratio

Subject to b) and c) below, $t_{REN,d/t}$ shall be determined in accordance with the following formula:

$$t_{REN,d/t} = (\text{web depth in mm})/R$$

where:

- for frames
 - $R = 65 k^{0.5}$ for symmetrically flanged frames,
 - $R = 55 k^{0.5}$ for asymmetrically flanged frames.
- for lower brackets (see a) below):
 - $R = 87 k^{0.5}$ for symmetrically flanged frames,
 - $R = 73 k^{0.5}$ for asymmetrically flanged frames,
 - $k = 1.0$ for ordinary hull structural steel and in accordance with sub-chapter 2.2 of *Part II – Hull of the Rules* for higher tensile steel.

In no instance shall $t_{REN,d/t}$ for lower integral brackets be taken as less than $t_{REN,d/t}$ for the frames they support.

a) Lower Brackets

Lower brackets shall be flanged or face plate shall be fitted.

In calculating the web depth of the lower brackets, the following will apply:

- .1 The web depth of lower bracket may be measured from the intersection of the sloped bulkhead of the hopper tank and the side shell plate, perpendicularly to the face plate of the lower bracket (see Figure 3).
- .2 Where stiffeners are fitted on the lower bracket plate, the web depth may be taken as the distance between the side shell and the stiffener, between the stiffeners or between the outermost stiffener and the face plate of the brackets, whichever is the greatest.

b) Tripping Bracket Alternative

When t_M is less than $t_{REN,d/t}$ at section b) of the side frames, tripping brackets in accordance with the requirements specified in sub-chapter 2.3 may be fitted as an alternative to the requirements for the web depth to thickness ratio of side frames, in which case $t_{REN,d/t}$ may be disregarded in the determination of t_{REN} in accordance with 2.1.2. The value of t_M is based on zone B (see Fig. 1). Where there are two existing tripping brackets supporting frames but their location is not in complete compliance with sub-chapter 2.3, i.e. one is located less than $h/3$ and the other – less than $2h/3$ from intersection of the hopper plate with the side shell, this may be accepted as equivalent to the requirements specified above, provided that the tripping bracket thickness is not less than the frame web thickness.

c) Immediately Aft Collision Bulkhead

For the side frames, including the lower bracket, located immediately abaft the collision bulkheads, whose scantlings are increased in order that their moment of inertia is such as to avoid undesirable flexibility of the side shell, when their web as built thickness t_{AB} is greater than 1.65. $t_{REN,S}$, the thickness $t_{REN,d/t}$ may be taken as the value $t_{REN,d/t}$ obtained from the following equation:

$$t'_{REN,d/t} = \sqrt[3]{t_{REN,d/t}^2 \cdot t_{REN,S}}$$

where $t_{REN,S}$ is obtained from 3.3.

2.1.2.2 Thickness Criteria Based on Shear Strength Check

Where t_M in the lower part of side frames, as defined in Figure 1, is equal to or less than t_{COAT} , $t_{REN,S}$ shall be determined in accordance with sub-chapter 3.3.

2.1.2.3 Thickness of Renewed Webs of Frames and Lower Brackets

Where steel renewal is required, the renewed webs shall be of a thickness not less than t_{AB} , $1.2t_{COAT}$ or $1.2t_{REN}$, whichever is the greatest.

2.1.2.4 Criteria for Other Measures

When $t_{REN} < t_M \leq t_{COAT}$, measures are to be taken, consisting of all the following:

- a) sand blasting, or equivalent, and coating (see sub-chapter 2.2).
- b) fitting tripping brackets (see sub-chapter 2.3), when the above condition occurs for any of the side frame zones A, B, C and D, shown in Figure 1.

Where tripping brackets are not connected to frame flanges, they shall have soft toe, and the distance between the bracket toe and the frame flange shall not be greater than 50 mm, see Fig. 4.

- c) maintaining the coating in "as-new" condition (i.e. without breakdown or rusting) at Special and Intermediate Surveys.

The above measures may be waived if the structural members show no thickness diminution with respect to the as built thicknesses and coating is in "as-new" condition (i.e. without breakdown or rusting).

When the measured frame webs thickness t_M is such that $t_{REN} < t_M \leq t_{COAT}$ and the coating is in GOOD condition (see *Publication No. 39/P*), sand blasting and coating as required in a) above may be waived even if not found in "as-new" condition, as defined above, provided that tripping brackets are fitted and the coating damage in way of the tripping bracket welding is repaired.

2.1.3 Criteria for Frames and Brackets (Bending Check)

When lower end brackets were not fitted with flanges at the design stage, flanges shall be fitted so as to fulfil the bending strength requirements specified in sub-chapter 3.4. The full width of the bracket flange shall extend up beyond the point at which the frame flange reaches its full width. Adequate back-up structure in the hopper shall be ensured, and the bracket shall be aligned with the back-up structure.

Where the length or depth of the lower bracket does not meet the requirements in sub-chapter 20.5 of *Part II – Hull of the Rules*, a bending strength check in accordance with sub-chapter 3.4 shall be performed and renewals or reinforcements of frames and/or brackets effected as required therein.

The bending check need not be performed where the bracket geometry is modified in accordance with sub-chapter 20.5 of *Part II – Hull of the Rules*.

2.2 Thickness Measurements, Steel Renewal, Sand Blasting, Coating and Repair of Damaged Frames

For the purpose of steel renewal, sand blasting and coating, four zones A, B, C and D are defined, as shown in Figure 1.

When renewal shall be performed, surface preparation and coating are required for the renewed structures as specified in paragraph 2.4.2 of *Part II – Hull of the Rules* for cargo holds of new buildings.

Representative thickness measurements shall be taken for each zone and shall be assessed in accordance with the criteria specified in sub-chapter 2.1.

When zone B is made up of different plate thicknesses, the lesser thickness shall be used to apply the requirements specified in this *Publication*.

In the case of integral brackets, when the criteria specified in sub-chapter 2.1 are not satisfied for zone A or B, steel renewal, sand blasting and coating, as applicable, shall be performed for both zones A and B.

In case of separate brackets, when the criteria specified in sub-chapter 2.1 are not satisfied for zone A or B, steel renewal, sand blasting and coating shall be performed for each of these zones, as applicable.

Where steel renewal is required for zone C in accordance with the criteria specified in sub-chapter 2.1, it shall be performed for both zones B and C. Where sand blasting and coating is required for zone C in accordance with sub-chapter 2.1, it shall be done for zones B, C and D.

Where steel renewal is required for zone D in accordance with sub-chapter 2.1, it needs only to be done for this zone. Where sand blasting and coating is required for zone D in accordance with sub-chapter 2.1, it shall be done for both zones C and D.

Special consideration shall be given to zones previously renewed or recoated, if found in “as-new” condition (i.e. without breakdown or rusting).

When adopted, on the basis of the renewal thickness criteria specified in sub-chapter 2.1, in general coating shall be applied in accordance with the requirements of sub-chapter 2.4.2 of *Part II – Hull of the Rules*, as applicable.

Where, according to the requirements specified in sub-chapter 2.1, a limited number of side frames and brackets are shown to require coating over part of their length, the following criteria apply.

- a) the part to be coated includes:
 - the web and the face plate of the side frames and brackets,
 - the hold surface of side shell, hopper tank and topside tank plating, as applicable, over a width not less than 100 mm from the web of the side frame.
- b) epoxy coating or equivalent shall be applied.

In all cases, all the surfaces to be coated shall be sand blasted prior to coating application.

When flanges of frames or brackets are to be renewed according to this *Publication*, the outstanding breadth to thickness ratio shall fulfil the requirements specified in sub-chapter 20.5.5 of *Part II – Hull of the Rules*.

Repair of damaged frames already complying with this *Publication*

In the case of renewal of a damaged frame already complying with the requirements specified in this *Publication*, the following shall be observed:

- replacements of rolled profile shall preferably be made of the same rolled section;
- built-up profiles are allowed in exceptional cases only. A repair made of an inserted built-up profile in a rolled profile could be acceptable provided some precautions are taken. The flange of the built-up profile shall overlap the repair area with snipped shape to smoothly allow the stresses to pass from the rolled profile to the built-up profile and vice versa.

Repair of damaged frames before implementation of this *Publication*

In the case of renewal of damaged frame before the date of implementation of this *Publication*, as built scantlings may be applied. For practical reasons, the decision on the renewal in accordance with the requirements specified in this *Publication* lies with the Owner.

2.3 Reinforcing Measures

Reinforcing measures are constituted by tripping brackets, located at the lower part and at midspan of side frames (see Fig. 4). Tripping brackets may be located at every second frame, but lower and midspan brackets shall be fitted in line between alternate pairs of frames.

The thickness of the tripping brackets shall not be less than the as-built thickness of the side frame webs to which they are connected.

Double continuous welding shall be adopted for the connections of tripping brackets to the side shell frames and shell plating.

Where side frames and side shell are made of higher strength steel (HSS), normal strength steel (NSS) tripping brackets may be accepted, provided the electrodes used for welding are those required in *Part IX* of the *Rules* for the particular HSS grade, and the thickness of the tripping brackets is equal to the frame web thickness, regardless of the frame web material.

2.4 Weld Throat Thickness

In case of steel renewal the welded connections shall fulfil the requirements specified in sub-chapter 20.5.7 of *Part II – Hull of the Rules*.

2.5 Pitting and Grooving

If pitting intensity is higher than 15% in area (see Fig. 5), thickness measurement shall be taken to check pitting corrosion.

The minimum acceptable remaining thickness in pits or grooves is equal to:

- 75% of the as built thickness, for pitting or grooving in the frame and brackets webs and flanges;
- 70% of the as built thickness, for pitting or grooving in the side shell, hopper tank and topside tank plating attached to the side frame, over a width up to 30 mm from each side of it.

2.6 Renewal of All Frames in One or More Cargo Holds

When all frames in one or more holds are required to be renewed in accordance with this *Publication*, the compliance with the requirements in Chapter 20.5 of the *Rules* may be accepted instead of the compliance with the requirements specified in this *Publication*, provided that:

- a) it is applied at least to all the frames of the hold(s).
- b) the coating requirements for side frames of “new ships” are fulfilled.
- c) the section modulus of side frames is calculated in accordance with the *Rules*.

2.7 Renewal of Damaged Frames

In the case of renewal of damaged frame already complying with this *Publication*, the following requirements apply:

- the conditions accepted in compliance with this *Publication* shall be restored as a minimum;
- for any local damage, the extension of the performed renewal shall be in accordance with the standard practice of PRS.

3 STRENGTH CHECK CRITERIA

In general, loads shall be calculated and strength checks shall be performed for the aft, middle and forward frames of each hold. The scantlings required for frames in intermediate positions shall be obtained by linear interpolation between the results obtained for the above frames.

When scantlings of side frames vary within a hold, the required scantlings shall also be calculated for the mid frame of each group of frames having the same scantlings. The scantlings required for frames in intermediate positions shall be obtained by linear interpolation between the results obtained for the calculated frames.

3.1 Load Model

The following loading conditions shall be considered:

- homogeneous heavy cargo (density greater than 1.78 t/m³),
- homogeneous light cargo (density less than 1.78 t/m³),
- non homogeneous heavy cargo, if allowed,
- multi port loading/unloading conditions need not be considered.

3.1.1 Forces

The forces $P_{fr,a}$ and $P_{fr,b}$, in [kN], to be considered for the strength checks at sections a) and b) of side frames (specified in Fig. 2; in the case of separate lower brackets, section b) is at the top of the lower bracket), shall be determined in accordance with the following formulae:

$$P_{fr,a} = P_S + \max(P_1, P_2)$$

$$P_{fr,b} = P_{fr,a} \frac{h - 2h_B}{h}$$

where:

P_S = still water force, [kN]

$$P_S = sh \left(\frac{P_{S,U} + P_{S,L}}{2} \right) \quad \text{when the upper end of side frame span } h \text{ (see Fig. 1) is below the load water line,}$$

$$P_S = sh' \left(\frac{P_{S,L}}{2} \right), \quad \text{when the upper end of the side frame span } h \text{ (see Fig. 1) is at or above the load water line,}$$

P_1 - wave force, in [kN], in head sea,

$$P_1 = sh \left(\frac{P_{1,U} + P_{1,L}}{2} \right),$$

P_2 - wave force, in [kN], in beam sea,

$$P_2 = sh \left(\frac{P_{2,U} + P_{2,L}}{2} \right),$$

h, h_B - side frame span and lower bracket length, in m, defined in Fig. 1 and Fig. 2, respectively,

h' - distance, in m, between the lower end of side frame span h (see Fig. 1) and the load water line,

s - frame spacing, [m],

$p_{S,U}, p_{S,L}$ - still water pressure, [kPa], at the upper and lower end of the side frame span h (see Figure 1), respectively,

$p_{1,U}, p_{1,L}$ - wave pressure, [kPa], as defined in 3.1.2.1 below for the upper and lower end of the side frame span h , respectively,

$p_{2,U}, p_{2,L}$ - wave pressure, [kPa], as defined in 3.1.2.2 below for the upper and lower end of the side frame span h , respectively.



3.1.2 Wave Pressure

.1 Wave Pressure p_1

- The wave pressure p_1 , [kPa], at and below the waterline shall be determined in accordance with the following formula:

$$p_1 = 1.50[p_{11} + 135 \frac{B}{2(B+75)} - 1.2(T - z)]$$

$$p_{11} = 3k_s C + k_f$$

- The wave pressure p_1 , [kPa], above the water line shall be determined in accordance with the formula below:

$$p_1 = p_{1wl} - 7.50(z - T).$$

.2 Wave Pressure p_2

- Wave pressure p_2 , [kPa], at and below the waterline shall be determined in accordance with the following formula:

$$p_2 = 13.0 \left[0.5B \frac{50c_r}{2(B + 75)} + \delta \frac{0.5B + k_f}{14} \left(0.7 + 2 \frac{z}{T} \right) \right]$$

- Wave pressure p_2 , [kPa], above the water line shall be determined in accordance with the formula below:

$$p_2 = p_{2wl} - 5.0(z - T)$$

where:

p_{1wl} - p_1 wave sea pressure at the waterline,

p_{2wl} - p_2 wave sea pressure at the waterline,

L_0 - rule length, [m], as defined in sub-chapter 1.2.2 of *Part II - Hull of the Rules*,

B - greatest moulded breadth, [m],

δ - block coefficient, as defined in sub-chapter 1.2.2 of *Part II - Hull of the Rules*, however not less than 0.6,

T - maximum design draught, [m],

C - coefficient,

$$C = 10.75 - \left(\frac{300 - L_0}{100} \right)^{1.5} \text{ for } 90 \leq L_0 \leq 300 \text{ m,}$$

$$C = 10.75 \text{ for } L_0 \geq 300 \text{ m,}$$

$$c_r = \left(1.25 - 0.025 \frac{2k_r}{\sqrt{GM}} \right) k$$

k = 1.2 for ships without bilge keel,

= 1.0 for ships with bilge keel,

k_r - roll radius of gyration; values of k_r given in Table 3.4 shall be applied,

GM = 0.12 B if the actual value of GM is not available,

z - vertical distance, [m], from the base plane to the load point,

$$k_s = \delta + \frac{0.83}{\sqrt{\delta}} \text{ at aft end of } L_0,$$

$$k_s = \delta \text{ between } 0.2 L_0 \text{ and } 0.6 L_0 \text{ from aft end of } L_0,$$

$$k_s = \delta + \frac{1.33}{\delta} \text{ at forward end of } L_0,$$

Between the above specified points, k_s shall be determined by linear interpolation.

$$k_f = 0.8C.$$

3.2 Allowable Stresses

The allowable normal and shear stresses σ_a and τ_a , [MPa], in the side shell frames and brackets are given by:

$$\sigma_a = 0.90R_e,$$

$$\tau_a = 0.40R_e,$$

where R_e – is the minimum upper yield stress, [MPa], of the material.

3.3 Shear Strength Check

Where t_M in the lower part of side frames, as defined in Fig. 1, is equal to, or less than, t_{COAT} , shear strength check shall be checked in accordance with the following pattern.

Thickness $t_{REN,S}$, in mm, is the greater value of the thicknesses $t_{REN,Sa}$ and $t_{REN,Sb}$ obtained from the shear strength check at sections a) and b) (see Fig. 2 and Fig. 3.1) given by the following, however need not be taken in excess of $0.75t_{20.5}$.

$$\text{– at section a) : } t_{REN,Sa} = \frac{1000k_s P_{fr,a}}{d_a \sin \phi \tau_a}$$

$$\text{– at section b) : } t_{REN,Sb} = \frac{1000k_s P_{fr,b}}{d_b \sin \phi \tau_a}$$

where:

k_s – shear force distribution factor, to be taken equal to 0.6,

$P_{fr,a}, P_{fr,b}$ – forces as defined in sub-chapter 3.1.1,

d_a, d_b – bracket and frame web depth, [mm], at sections a) and b), respectively (see Fig. 2); in the case of separate (non integral) brackets, d_b shall be taken as the minimum web depth deducing possible scallops,

ϕ – angle between frame web and shell plate,

τ_a – allowable shear stress, [MPa], as defined in sub-chapter 3.2.

3.4 Bending Strength Check

Where the lower bracket length or depth does not fulfil the requirements specified in sub-chapter 20.5 of *Part II – Hull of the Rules*, the actual section modulus, [cm³], of the brackets and side frames at sections a) and b) shall not be less than:

– at section a):

$$W_a = \frac{1000P_{fr,a}h}{m_a\sigma_a}$$

– at section b):

$$W_b = \frac{1000P_{fr,b}h}{m_b\sigma_a}$$

where:

$P_{fr,a}$ – force as defined in sub-chapter 3.1.1,

h – side frame span, [m], as defined in Fig. 1,

σ_a – allowable normal stress, [MPa], as defined in sub-chapter 3.2,

m_a, m_b – bending moment coefficients specified in Table 3.4.

Table 3.4 – Bending moment coefficients m_a and m_b

	k_r	m_a	m_b		
			$h_b \leq 0.08h$	$h_b = 0.1 h$	$h_b \geq 0.125 h$
Empty holds of ships allowed to operate in non homogeneous loading conditions	0.39 B	10	17	19	22
Loaded holds of ships allowed to carry only light cargo (density less than 1.78 t/m ³)	0.39 B	12	20	22	26
Other cases*	0.25 B	12	20	22	26

* – this represents the loaded hold of a ship in homogeneous heavy cargo loading condition, which is more severe than a loaded hold in non homogeneous cargo condition.
 Note 1: Non homogeneous loading condition means a loading condition in which the ratio between the highest and the lowest filling ratio, evaluated for each hold, exceeds 1.20 corrected for different cargo densities.
 Note 2: For intermediate values of the bracket length h_b , the coefficient m_b shall be obtained by linear interpolation between the table values.

The actual section modulus of the brackets and side frames shall be calculated about an axis parallel to the attached plate, based on the measured thicknesses. For precalculations, alternative thickness values may be used, provided they are not less than:

- t_{REN} , for the web thickness,
- the minimum thicknesses allowed by PRS renewal criteria for flange and attached plating.

The attached plate breadth is equal to the frame spacing, measured along the shell at midspan of h .

If the actual section moduli at sections a) and b) are less than the values W_a and W_b , the frames and brackets shall be renewed or reinforced in order to obtain actual section moduli not less than 1.2 W_a and 1.2 W_b , respectively.

In that case, renewal or reinforcements of the flange shall be extended over the lower part of side frames, as defined in Fig. 1.

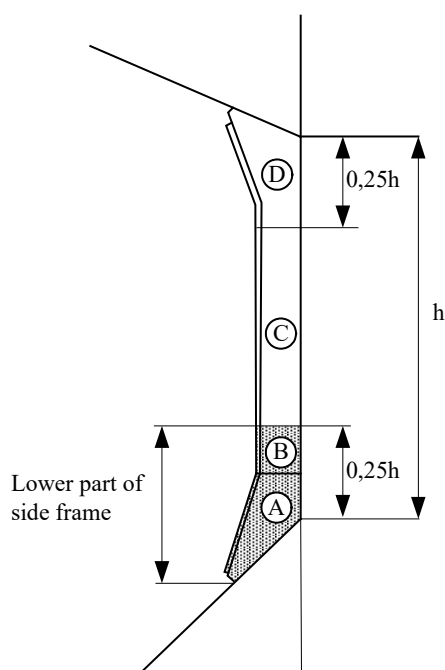

Fig. 1 Lower part and zones of side frames

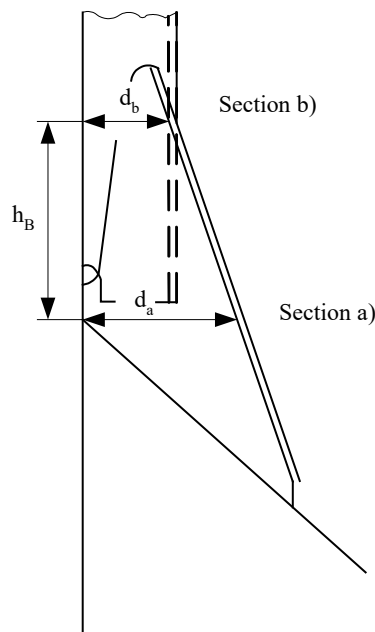
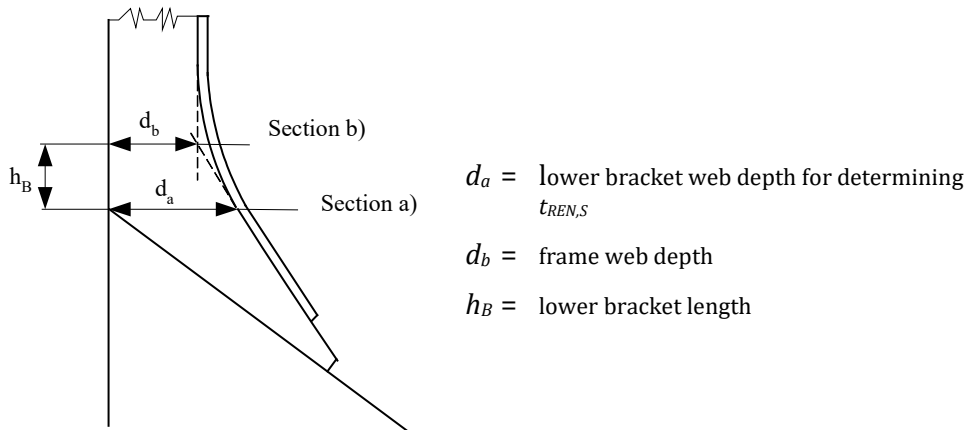

Fig. 2 Sections a) and b)

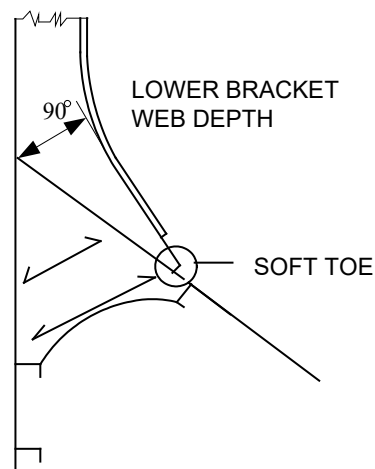

Fig. 3 Definition of the lower bracket web depth for determining $t_{REN,d/t}$

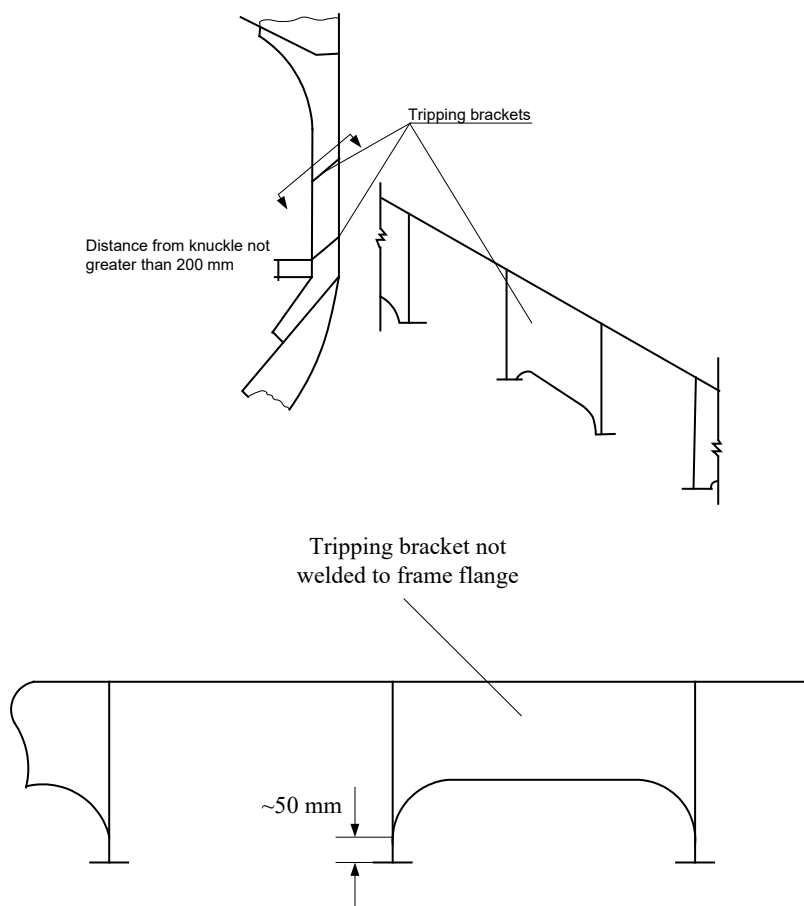

Fig. 4 Tripping brackets

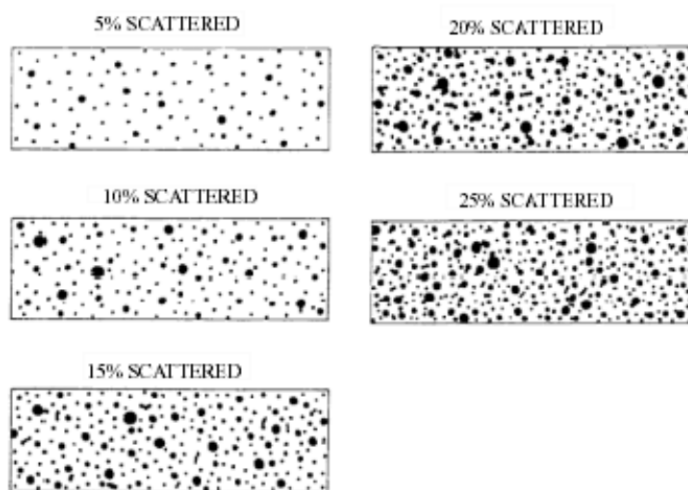

Fig. 5 Pitting intensity diagrams (from 5% to 25% intensity)