

Polski Rejestr Statków

RULES

PUBLICATION NO. 110/P

RUDDERS, SOLE PIECES AND RUDDER HORNS FOR CSR BULK CARRIERS

2015

Publications P (Additional Rule Requirements) issued by Polski Rejestr Statków
complete or extend the Rules and are mandatory where applicable



GDAŃSK

The requirements of this *Publication* extend the requirements of the *Rules for the Classification and Construction of Sea-going Ships*, hereinafter referred to as the *Rules*. These requirements come from *CSR-BC, Chapter 10, Section 1*.

This *Publication* was approved by the PRS Board on 12 June 2015 and enters into force on 1 July 2015. Its validity expires on 30 June 2016.

© Copyright by Polski Rejestr Statków S.A., 2015

CONTENTS

	Page
1 General	5
1.0 Symbols.....	5
1.1 Scope of application.....	5
1.2 Structural details.....	6
1.3 Materials.....	6
2 Rudder Force and Torque	6
2.1 Rudder force and torque for normal rudders.....	6
2.2 Rudder force and torque for rudder blades with cut-outs (semi-spade rudders).....	7
3 Scantlings of the Rudder Stock	9
3.1 Rudder stock diameter.....	9
3.2 Strengthening of rudder stock.....	9
3.3 Analysis.....	10
3.4 Rudder trunk.....	14
4 Rudder Couplings	14
4.1 General.....	14
4.2 Horizontal couplings.....	15
4.3 Vertical couplings.....	15
4.4 Cone couplings with key.....	16
4.5 Cone couplings with special arrangements for mounting and dismounting the couplings.....	17
5 Rudder Body, Rudder Bearings	19
5.1 Strength of rudder body.....	19
5.2 Rudder plating.....	20
5.3 Connections of rudder blade structure with solid parts in forged or cast steel.....	21
5.4 Rudder bearings.....	23
5.5 Pintles.....	24
5.6 Criteria for bearing clearances.....	25
6 Design Yield Moment of Rudder Stock	25
6.1 General.....	25
7 Stopper, Locking Device	25
7.1 Stopper.....	25
7.2 Locking device.....	25
7.3 Stopper and locking device.....	25
8 Propeller Nozzles	25
8.1 General.....	25
8.2 Design pressure.....	26
8.3 Plate thickness.....	26
8.4 Section modulus.....	27
8.5 Welding.....	27
9 Rudder Horn and Sole Piece Scantlings	27
9.1 Sole piece.....	27
9.2 Rudder horn of semi spade rudders (case of 1-elastic support).....	28
9.3 Rudder horn of semi spade rudders (case of 2-conjugate elastic supports).....	30
10 Rudder Coupling Flanges	33
10.1 Connections of rudder coupling flanges.....	33

1 GENERAL

1.0 Symbols

C_R – rudder force, [N];

Q_R – rudder torque, [Nm];

A – total movable area of the rudder, measured at the mid-plane of the rudder, [m²];

For nozzle rudders, A is not to be taken less than 1.35 times the projected area of the nozzle.

A_t – area equal to A + area of a rudder horn, if any, [m²];

A_f – portion of rudder area located ahead of the rudder stock axis, [m²];

b – mean height of rudder area, [m];

c – mean breadth of rudder area, in m, see Fig 1.0

Λ – aspect ratio of rudder area A_t , taken equal to:

$$\Lambda = \frac{b^2}{A_t}$$

V_0 – maximum ahead speed, as defined in 1.4. If this speed is less than 10 knots, V_0 is to be replaced by:

$$V_{\min} = \frac{(V_0 + 20)}{3}, [\text{knots}]$$

V_a – maximum astern speed, in knots, to be taken not less than $0.5V_0$. For greater astern speeds special evaluation of rudder force and torque as a function of the rudder angle may be required. If no limitations for the rudder angle at astern condition is stipulated, the factor κ_2 is not to be taken less than given in Tab 2.1.1 for astern condition.

For symbols not defined in this Publication, refer to *Rules for the Classification and Construction of Sea-going Ships, Part III – Hull Equipment, Chapter 2*.

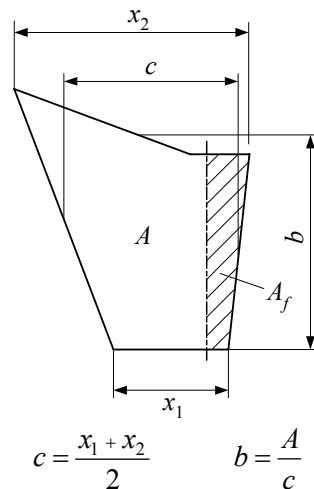

Figure 1.0 Dimensions of rudder

1.1 Scope of application

1.1.1 This Publication applies to single side skin and double side skin bulk carriers¹ with unrestricted worldwide navigation, having length L of 90m and above which are classed with Polish Register of Shipping (called PRS hereafter).

1.1.2 The manoeuvring arrangement includes all parts from the rudder and steering gear to the steering position necessary for steering the ship.

1.1.3 Rudder stock, rudder coupling, rudder bearings and the rudder body are dealt with in this Publication. The steering gear is to comply with the appropriate PRS Rules.

¹ See the definition of bulk carriers in Common Structural Rules (CSR)

1.2 Structural details

1.2.1 Effective means are to be provided for supporting the weight of the rudder body without excessive bearing pressure, e.g. by a rudder carrier attached to the upper part of the rudder stock. The hull structure in way of the rudder carrier is to be suitably strengthened.

1.2.2 Suitable arrangements are to be provided to prevent the rudder from lifting.

1.2.3 Connections of rudder blade structure with solid parts in forged or cast steel, which are used as rudder stock housing, are to be suitably designed to avoid any excessive stress concentration at these areas.

1.2.4 The rudder stock is to be carried through the hull either enclosed in a watertight trunk, or glands are to be fitted above the deepest load waterline, to prevent water from entering the steering gear compartment and the lubricant from being washed away from the rudder carrier. If the top of the rudder trunk is below the deepest waterline two separate stuffing boxes are to be provided.

1.3 Materials

1.3.1 For materials for rudder stock, pintles, coupling bolts etc. refer to the PRS Rules for the Classification and Construction of Sea-going Ships, *Part IX: Materials and Welding*.

1.3.2 In general, materials having R_{eH} of less than 200 N/mm² and R_m of less than 400 N/mm² or more than 900 N/mm² are not to be used for rudder stocks, pintles, keys and bolts. The requirements of 10.1 are based on a with R_{eH} of 235 N/mm². If material is used having a R_{eH} differing from 235 N/mm², the material factor k_r is to be determined as follows:

$$k_r = \left(\frac{235}{R_{eH}} \right)^{0.75} \quad \text{for } R_{eH} > 235 \quad (1.3.2-1)$$

$$k_r = \frac{235}{R_{eH}} \quad \text{for } R_{eH} \leq 235 \quad (1.3.2-2)$$

where:

R_{eH} – minimum yield stress of material used, in N/mm². R_{eH} is not to be taken greater than $0.7R_m$ or 450 N/mm², whichever is less.

1.3.3 Before significant reductions in rudder stock diameter due to the application of steels with R_{eH} exceeding 235 N/mm² are accepted, PRS may require the evaluation of the elastic rudder stock deflections. Large deflections should be avoided in order to avoid excessive edge pressures in way of bearings.

1.3.4 The permissible stresses given in 5.1 are applicable for normal strength steel. When higher strength steels are used, higher values may be used for the permissible stresses, on a case by case basis.

2 RUDDER FORCE AND TORQUE

2.1 Rudder force and torque for normal rudders

2.1.1 The rudder force is to be determined according to the following formula:

$$C_R = 132AV^2 \kappa_1 \kappa_2 \kappa_3 \kappa_t \quad [\text{N}] \quad (2.1.1)$$

where:

V – V_0 for ahead condition,
 V_a for astern condition;

κ_1 – coefficient, depending on the aspect ratio Λ , taken equal to:
 $\kappa_1 = (\Lambda + 2)/3$, where Λ need not be taken greater than 2;

κ_2 – coefficient depending on the type of the rudder and the rudder profile according to Tab 2.1.1.

Table 2.1.1
Coefficient κ_2

Profile/type of rudder	κ_2	
	Ahead	Astern
NACA-00 series Göttingen profiles	1.10	0.80
Flat side profiles	1.10	0.90
Mixed profiles (e. g. HSVA)	1.21	0.90
Hollow profiles	1.35	0.90
High lift rudders	1.70	to be specially considered; if not known: 1.30
Fish tail	1.40	0.80
Single plate	1.00	1.00

- κ_3 – coefficient, depending on the location of the rudder, taken equal to:
 $\kappa_3 = 0.80$ for rudders outside the propeller jet,
 $\kappa_3 = 1.00$ elsewhere, including also rudders within the propeller jet,
 $\kappa_3 = 1.15$ for rudders aft of the propeller nozzle;
- κ_r – coefficient equal to 1.0 for rudders behind propeller. Where a thrust coefficient $C_{Th} > 1.0$, PRS may consider a coefficient κ_r different from 1.0, on a case by case basis.

2.1.2 The rudder torque is to be determined by the following formula:

$$Q_R = C_R r, \text{ [Nm]} \quad (2.1.2-1)$$

where:

- r – lever of the force C_R , in m, taken equal to:
 $r = c(\alpha - k_{bc})$, without being less than $0.1c$ for ahead condition;

- α – coefficient taken equal to:
 $\alpha = 0.33$ for ahead condition,
 $\alpha = 0.66$ for astern condition (general),
 $\alpha = 0.75$ for astern condition (hollow profiles).
 For parts of a rudder behind a fixed structure such as a rudder horn:
 $\alpha = 0.25$ for ahead condition,
 $\alpha = 0.55$ for astern condition.

For high lift rudders α is to be specially considered. If not known, $\alpha = 0.40$ may be used for the ahead condition.

- k_{bc} – balance factor as follows:

$$k_{bc} = \frac{A_f}{A} \quad (2.1.2-2)$$

$$k_{bc} = 0.08 \text{ for unbalanced rudders} \quad (2.1.2-3)$$

2.1.3 Effects of the provided type of rudder/profile on choice and operation of the steering gear are to be observed.

2.2 Rudder force and torque for rudder blades with cut-outs (semi-spade rudders)

2.2.1 The total rudder force C_R is to be calculated according to 2.1.1. The pressure distribution over the rudder area, upon which the determination of rudder torque and rudder blade strength are to be based, is to be obtained as follows:

- the rudder area may be divided into two rectangular or trapezoidal parts with areas A_1 and A_2 , see Fig 2.2.1
- the resulting force, in N, of each part may be taken as:

$$C_{R1} = C_R \frac{A_1}{A}, \text{ [N]} \quad (2.2.1-1)$$

$$C_{R2} = C_R \frac{A_2}{A}, \text{ [N]} \quad (2.2.1-2)$$

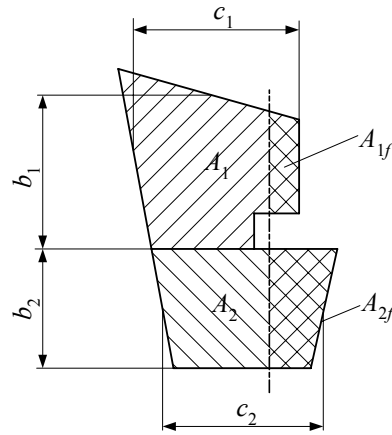

Figure 2.2.1 Areas A_1 and A_2

2.2.2 The resulting torque of each part is to be taken as:

$$Q_{R1} = C_{R1} r_1, \text{ [Nm]} \quad (2.2.2-1)$$

$$Q_{R2} = C_{R2} r_2, \text{ [Nm]} \quad (2.2.2-2)$$

where:

$$r_1 = c_1(\alpha - k_{b1}), \text{ [m]}; \quad (2.2.2-3)$$

$$r_2 = c_2(\alpha - k_{b2}), \text{ [m]}; \quad (2.2.2-4)$$

$$k_{b1} = \frac{A_{1f}}{A_1} \quad (2.2.2-5)$$

$$k_{b2} = \frac{A_{2f}}{A_2} \quad (2.2.2-6)$$

A_{1f}, A_{2f} – as defined in Fig 2.2.1;

$$c_1 = \frac{A_1}{b_1}, \text{ [m]} \quad (2.2.2-7)$$

$$c_2 = \frac{A_2}{b_2}, \text{ [m]} \quad (2.2.2-8)$$

b_1, b_2 – mean heights of the partial rudder areas A_1 and A_2 (see Fig 2.2.1).

2.2.3 The total rudder torque is to be determined according to the following formulae:

$$Q_R = Q_{R1} + Q_{R2}, \text{ [Nm]} \text{ without being less than } Q_{R \min} = C_R r_{1,2 \min} \quad (2.2.3)$$

where:

$$r_{1,2 \min} = \frac{0.1}{A} (c_1 A_1 + c_2 A_2), \text{ [m]}.$$

3 SCANTLINGS OF THE RUDDER STOCK

3.1 Rudder stock diameter

3.1.1 The diameter of the rudder stock for transmitting the rudder torque is not to be less than:

$$D_t = 4.2\sqrt[3]{Q_R k_r}, \text{ [mm]} \quad (3.1.1-1)$$

where:

Q_R – as defined in 2.1.2, 2.2.2 and 2.2.3.

The related torsional stress is:

$$\tau_t = \frac{68}{k_r}, \text{ [N/mm}^2\text{]} \quad (3.1.1-2)$$

where:

k_r – as defined in 4.2 and 4.3.

3.1.2 The diameter of the rudder stock determined according to 3.1.1 is decisive for the steering gear, the stopper and the locking device.

3.1.3 In case of mechanical steering gear the diameter of the rudder stock in its upper part which is only intended for transmission of the torsional moment from the auxiliary steering gear may be $0.9D_t$. The length of the edge of the quadrangle for the auxiliary tiller must not be less than $0.77D_t$ and the height not less than $0.8D_t$.

3.1.4 The rudder stock is to be secured against axial sliding. The degree of the permissible axial clearance depends on the construction of the steering engine and on the bearing.

3.2 Strengthening of rudder stock

3.2.1 If the rudder is so arranged that additional bending stresses occur in the rudder stock, the stock diameter has to be suitably increased. The increased diameter is, where applicable, decisive for the scantlings of the coupling. For the increased rudder stock diameter the equivalent stress of bending and torsion is not to exceed the following value:

$$\sigma_v = \sqrt{\sigma_b^2 + 3\tau^2} \leq \frac{118}{k_r}, \text{ [N/mm}^2\text{]} \quad (3.2.1-1)$$

where:

σ_b – bending stress, equal to:

$$\sigma_{bD} = \frac{10.2M_b}{D_1^3}, \text{ [N/mm}^2\text{]} \quad (3.2.1-2)$$

M_b – bending moment at the neck bearing, [Nm];

τ – torsional stress, equal to:

$$\tau = \frac{5.1Q_R}{D_1^3}, \text{ [N/mm}^2\text{]} \quad (3.2.1-3)$$

D_1 – increased rudder stock diameter, equal to:

$$D_1 = 0.1D_t \cdot \sqrt[6]{1 + \frac{4}{3} \left(\frac{M_b}{Q_R} \right)^2}, \text{ [cm]} \quad (3.2.1-4)$$

Q_R – as defined in 2.1.2, 2.2.2 and 2.2.3;

D_t – as defined in 3.1.1.

Note: Where a double-piston steering gear is fitted, additional bending moments may be transmitted from the steering gear into the rudder stock. These additional bending moments are to be taken into account for determining the rudder stock diameter.

3.3 Analysis

3.3.1 General

The bending moments, shear forces and support forces for the system rudder – rudder stock are to be obtained from 3.3.2 and 3.3.3, for rudder types as shown in Fig 3.3.3-1 to Fig 3.3.3-5.

3.3.2 Data for the analysis

l_{10}, \dots, l_{50} – lengths of the individual girders of the system, [m];

I_{10}, \dots, I_{50} – moments of inertia of these girders, [cm⁴];

For rudders supported by a sole piece the length ℓ_{20} is the distance between lower edge of rudder body and centre of sole piece, and I_{20} is the moment of inertia of the pintle in the sole piece.

Load on rudder body, (general):

$$p_R = \frac{C_R}{10^3 \ell_{10}}, \text{ [kN/m]} \quad (3.3.2-1)$$

Load on semi-spade rudders:

$$p_{R10} = \frac{C_{R2}}{10^3 \ell_{10}}, \text{ [kN/m]} \quad (3.3.2-2)$$

$$p_{R20} = \frac{C_{R1}}{10^3 \ell_{20}}, \text{ [kN/m]} \quad (3.3.2-3)$$

C_R, C_{R1}, C_{R2} – as defined in 2.1 and 2.2;

Z – spring constant of support in the sole piece or rudder horn respectively:
for the support in the sole piece (see Fig 3.3.3-1):

$$Z = \frac{6.18 I_{50}}{\ell_{50}^3}, \text{ [kN/m]} \quad (3.3.2-4)$$

for the support in the rudder horn (see Fig 3.3.3-2):

$$Z = \frac{1}{f_b + f_t}, \text{ [kN/m]} \quad (3.3.2-4)$$

f_b – unit displacement of rudder horn due to a unit force of 1 kN acting in the centre of support:

$$f_b = \frac{1.3d^3 10^8}{3EI_n}, \text{ [m/kN]} \quad (3.3.2-5)$$

$$f_b = 0.21 \frac{d^3}{I_n}, \text{ [m/kN]} \text{ (guidance value for steel)} \quad (3.3.2-6)$$

I_n – moment of inertia of rudder horn around the x -axis at $d/2$ (see Fig 3.3.3-2), [cm⁴];

f_t – unit displacement due to a torsional moment of the amount 1:

$$f_t = \frac{de^2}{GJ_t}, \text{ [m/kN]} \quad (3.3.2-7)$$

$$f_t = \frac{de^2 \sum u_i / t_i}{3.17 \cdot 10^8 F_T^2}, \text{ [m/kN]} \text{ for steel} \quad (3.3.2-8)$$

G – modulus of rigidity, [kN/m²];

$G = 7.96 \cdot 10^7$ kN/m² for steel;

J_t – torsional moment of inertia, [m⁴];

F_T – mean sectional area of rudder horn, [m²];

u_i – breadth of the individual plates forming the mean horn sectional area, [mm];

t_i – plate thickness of individual plate having breadth u_i , [mm];
 e, d – distances according to Fig 3.3.3-2, [m];
 K_{11}, K_{22}, K_{12} – rudder horn compliance constants calculated for rudder horn with 2-conjugate elastic supports (Fig 3.3.3-3). The 2-conjugate elastic supports are defined in terms of horizontal displacements, y_i by the following equations:

at the lower rudder horn bearing:

$$y_1 = -K_{12}F_{A2} - K_{22}F_{A1} \quad (3.3.2-9)$$

at the upper rudder horn bearing:

$$y_2 = -K_{11}F_{A2} - K_{12}F_{A1} \quad (3.3.2-10)$$

where:

y_1, y_2 – horizontal displacements at the lower and upper rudder horn bearings, respectively, [m];
 F_{A1}, F_{A2} – horizontal support forces at the lower and upper rudder horn bearings, respectively, [kN];
 K_{11}, K_{22}, K_{12} – obtained from the following formulae:

$$K_{11} = 1.3 \frac{\lambda^3}{3EJ_{1h}} + \frac{e^2 \lambda}{GJ_{th}}, \quad [\text{m/kN}] \quad (3.3.2-11)$$

$$K_{12} = 1.3 \left[\frac{\lambda^3}{3EJ_{1h}} + \frac{\lambda^2(d-\lambda)}{2EJ_{1h}} \right] + \frac{e^2 \lambda}{GJ_{th}}, \quad [\text{m/kN}] \quad (3.3.2-12)$$

$$K_{22} = 1.3 \left[\frac{\lambda^3}{3EJ_{1h}} + \frac{\lambda^2(d-\lambda)}{2EJ_{1h}} + \frac{\lambda(d-\lambda)^2}{EJ_{1h}} + \frac{(d-\lambda)^3}{3EJ_{2h}} \right] + \frac{e^2 d}{GJ_{th}}, \quad [\text{m/kN}] \quad (3.3.2-13)$$

d – height of the rudder horn defined in Fig 3.3.3-3, [m]. This value is measured downwards from the upper rudder horn end, at the point of curvature transition, till the mid-line of the lower rudder horn pintle;

λ – length, as defined in Fig 3.3.3-3, [m]. This length is measured downwards from the upper rudder horn end, at the point of curvature transition, till the mid-line of the upper rudder horn bearing. For $\lambda = 0$, the above formulae converge to those of spring constant Z for a rudder horn with 1-elastic support, and assuming a hollow cross section for this part;

e – rudder-horn torsion lever, as defined in Fig 3.3.3-3 (value taken at $z = d/2$), [m];

J_{1h} – moment of inertia of rudder horn about the x axis for the region above the upper rudder horn bearing, [m⁴]. Note that J_{1h} is an average value over the length λ (see Fig 3.3.3-3);

J_{2h} – moment of inertia of rudder horn about the x axis for the region between the upper and lower rudder horn bearings, [m⁴]. Note that J_{2h} is an average value over the length $d - \lambda$ (see Fig 3.3.3-3);

J_{th} – torsional stiffness factor of the rudder horn, [m⁴]:

For any thin wall closed section

$$J_{th} = \frac{4F_T^2}{\sum_i \frac{u_i}{t_i}}, \quad [\text{m}^4] \quad (3.3.2-14)$$

F_T – mean of areas enclosed by outer and inner boundaries of the thin walled section of rudder horn, [m²];

u_i – length of the individual plates forming the mean horn sectional area, [mm];

t_i – thickness of the individual plates mentioned above, [mm].

Note that the J_{th} value is taken as an average value, valid over the rudder horn height.

3.3.3 Moments and forces to be evaluated

The bending moment M_R and the shear force Q_1 in the rudder body, the bending moment M_b in the neck bearing and the support forces B_1, B_2, B_3 are to be evaluated.

The so evaluated moments and forces are to be used for the stress analyses required by 3.2, 5, 9.1 and 9.2.

- i) for spade rudders (see Fig 3.3.3-4) the moments and forces may be determined by the following formulae:

$$M_b = C_R \left(\ell_{20} + \frac{\ell_{10}(2x_1 + x_2)}{2(x_1 + x_2)} \right), \text{ [Nm]} \quad (3.3.3-1)$$

$$B_3 = \frac{M_b}{\ell_{30}}, \text{ [N]} \quad (3.3.3-2)$$

$$B_2 = C_R + B_3, \text{ [N]} \quad (3.3.3-3)$$

- ii) for spade rudders with rudders trunks (see Fig 10.1.3.3.3-5) the moments and forces may be determined by the following formulae:

M_R is the greatest of the following values:

$$M_R = C_{R2}(\ell_{10} - CG_{2Z}), \text{ [Nm]} \quad (3.3.3-4a)$$

$$M_R = C_{R1}(CG_{1Z} - \ell_{10}), \text{ [Nm]} \quad (3.3.3-4b)$$

where:

C_{R1} – rudder force over the rudder blade area A_1 , [N];

C_{R2} – rudder force over the rudder blade area A_2 , [N];

CG_{1Z} – vertical position of the centre of gravity of the rudder blade area A_1 , [m];

CG_{2Z} – vertical position of the centre of gravity of the rudder blade area A_2 , [m].

$$M_B = C_{R2}(\ell_{10} - CG_{2Z}), \text{ [Nm]} \quad (3.3.3-5)$$

$$B_3 = (M_B + M_{CR1})/(\ell_{20} + \ell_{30}), \text{ [N]} \quad (3.3.3-6)$$

$$B_2 = C_R + B_3, \text{ [N]} \quad (3.3.3-7)$$

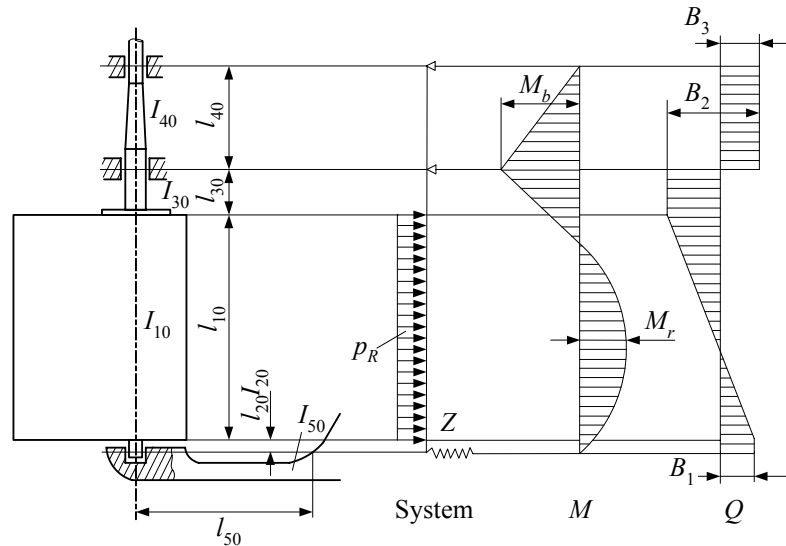

Figure 3.3.3-1 Rudder supported by sole piece

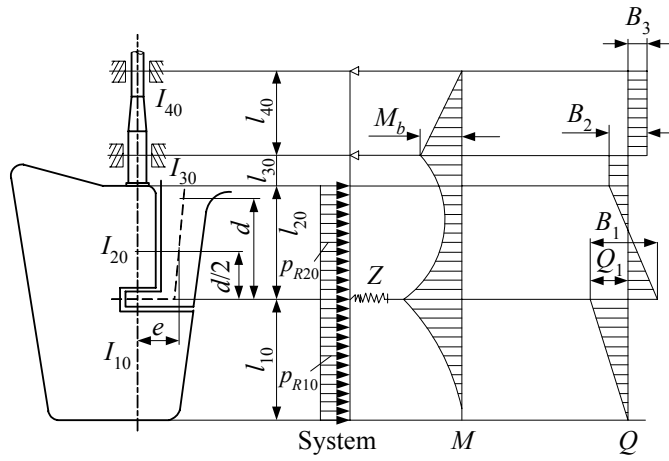

Figure 3.3.3-2 Semi-spade rudder (with 1-elastic support)

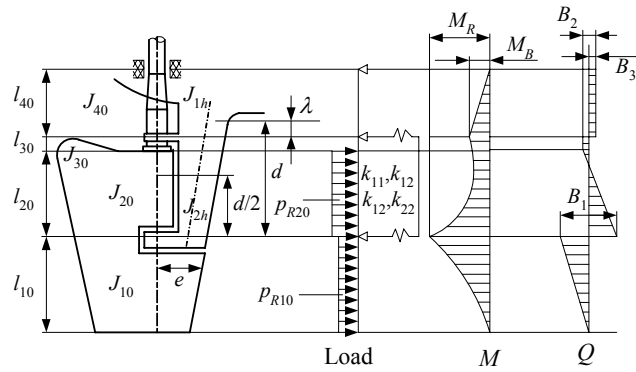

Figure 3.3.3-3 Semi-spade rudder (with 2-conjugate elastic supports)

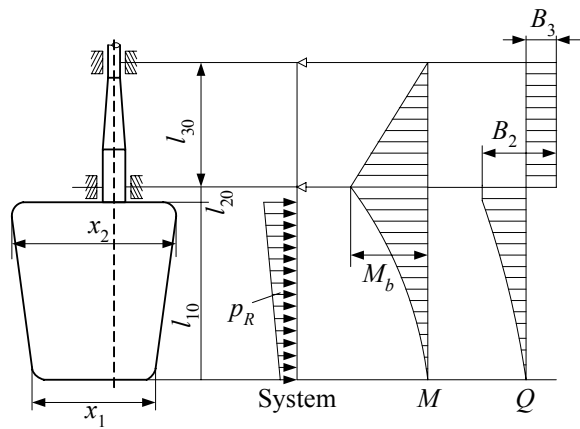

Figure 3.3.3-4 Spade rudder

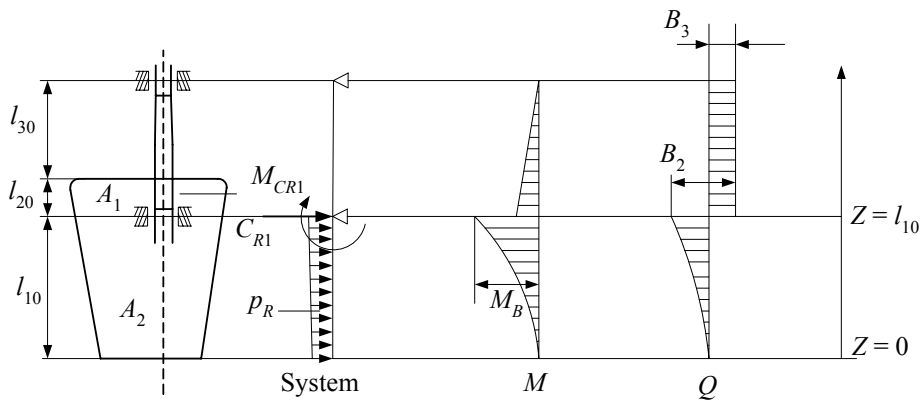

Figure 3.3.3-5 Spade rudders with rudder trunks

3.4 Rudder trunk

3.4.1 Where the rudder stock is arranged in a trunk in such a way that the trunk is stressed by forces due to rudder action, the scantlings of the trunk are to be as such that the equivalent stress due to bending and shear does not exceed $0.35 R_{eH}$ of the material used.

3.4.2 In case where the rudder stock is fitted with a rudder trunk welded in such a way the rudder trunk is loaded by the pressure induced on the rudder blade, as given in 2.1.1, the bending stress in the rudder trunk is to be in compliance with the following formula:

$$\sigma \leq 80/k, \text{ [N/mm}^2\text{]} \quad (3.4.2)$$

where the material factor k for the rudder trunk is not to be taken less than 0.7.

For the calculation of the bending stress, the span to be considered is the distance between the mid-height of the lower rudder stock bearing and the point where the trunk is clamped into the shell or the bottom of the skeg.

3.4.3 The steel used for the rudder trunk is to be of weldable quality, with a carbon content not exceeding 0.23% on ladle analysis and a carbon equivalent CEQ not exceeding 0.41.

3.4.4 The weld at the connection between the rudder trunk and the shell or the bottom of the skeg is to be full penetration.

The fillet shoulder radius r , in mm, is to be as large as practicable and to comply with the following formulae:

$$\text{i) } r = 60, \text{ [mm], when } \sigma \geq 40/k \text{ N/mm}^2 \quad (3.4.4-1)$$

$$r = 0.1D_1, \text{ [mm], without being less than 30 when } \sigma < 40/k \text{ [N/mm}^2\text{]} \quad (3.4.4-2)$$

where D_1 is defined in 3.2.1.

The radius may be obtained by grinding. If disk grinding is carried out, score marks are to be avoided in the direction of the weld.

The radius is to be checked with a template for accuracy. Four profiles at least are to be checked. A report is to be submitted to the Surveyor.

3.4.5 Before welding is started, a detailed welding procedure specification is to be submitted to PRS covering the weld preparation, welding positions, welding parameters, welding consumables, preheating, post weld heat treatment and inspection procedures. This welding procedure is to be supported by approval tests in accordance with the applicable requirements of materials and welding sections of the rules.

The manufacturer is to maintain records of welding, subsequent heat treatment and inspections traceable to the welds. These records are to be submitted to the Surveyor.

3.4.6 Non destructive tests are to be conducted at least 24 hours after completion of the welding. The welds are to be 100% magnetic particle tested and 100% ultrasonic tested. The welds are to be free from cracks, lack of fusion and incomplete penetration. The non destructive tests reports are to be handed over to the Surveyor.

3.4.7 Rudder trunks in materials other than steel are to be specially considered by PRS.

3.4.8 The thickness of the shell or of the bottom plate is to be compatible with the trunk thickness.

4 RUDDER COUPLINGS

4.1 General

4.1.1 The couplings are to be designed in such a way as to enable them to transmit the full torque of the rudder stock.

4.1.2 The distance of the bolt axis from the edges of the flange is not to be less than 1.2 times the diameter of the bolt.

In horizontal couplings, at least 2 bolts are to be arranged forward of the stock axis.

4.1.3 The coupling bolts are to be fitted bolts. The bolts and nuts are to be effectively secured against loosening.

4.1.4 For spade rudders, horizontal couplings according to 4.2 are permitted only where the required thickness of the coupling flanges t_f is less than 50 mm, otherwise cone coupling according to 4.4 or 4.5, as applicable, is to be applied. For spade rudders of the high lift type, only cone coupling according to 4.4 or 4.5, as applicable, is permitted.

4.2 Horizontal couplings

4.2.1 The diameter of coupling bolts, in mm, is not to be less than:

$$d_b = 0.62 \sqrt{\frac{D^3 k_b}{k_r n e}}, \text{ [mm]} \quad (4.2.1)$$

where:

- D - rudder stock diameter according to Chapter 6, [mm];
- n - total number of bolts, which is not to be less than 6;
- e - mean distance of the bolt axes from the centre of bolt system, [mm];
- k_r - material factor for the rudder stock as defined in 1.4.2;
- k_b - material factor for the bolts, obtained according to 1.4.2.

4.2.2 The thickness of the coupling flanges is not to be less than determined by the following formulae:

$$t_f = 0.62 \sqrt{\frac{D^3 k_f}{k_r n e}}, \text{ [mm]}, \text{ without being less than } 0.9d_b \quad (4.2.2)$$

where:

- k_f — material factor for the coupling flanges, obtained according to 1.4.2.
- The thickness of the coupling flanges clear of the bolt holes is not to be less than $0.65 t_f$.
- The width of material outside the bolt holes is not to be less than $0.67d_b$.

4.2.3 The coupling flanges are to be equipped with a fitted key according to DIN 6885 or equivalent standard for relieving the bolts.

The fitted key may be dispensed with if the diameter of the bolts is increased by 10%.

4.2.4 Horizontal coupling flanges are to be either forged together with the rudder stock or welded to the rudder stock, according to 10.1.3.

4.2.5 For the connection of the coupling flanges with the rudder body, see also 10.1.10.

4.3 Vertical couplings

4.3.1 The diameter of the coupling bolts is not to be less than:

$$d_b = \frac{0.81D}{\sqrt{n}} \sqrt{\frac{k_b}{k_r}}, \text{ [mm]} \quad (4.3.1)$$

where:

- D, k_b, k_r, n are defined in 4.2.1, where n is not to be less than 8.

4.3.2 The first moment of area of the bolts about the centre of the coupling is not to be less than:

$$S = 0.00043D^3, \text{ [cm}^3\text{]} \quad (4.3.2)$$

4.3.3 The thickness of the coupling flanges, in mm, is not to be less than $t_f = d_b$.
The width of material outside the bolt holes is not to be less than $0.67 d_b$.

4.4 Cone couplings with key

4.4.1 Cone couplings should have a taper c on diameter of 1:8 to 1:12, where (see Fig 4.4.1):

$$c = (d_0 - d_u) / \ell \quad (4.4.1)$$

The cone shapes are to fit very exact. The nut is to be carefully secured, e.g. by a securing plate as shown in Fig 4.4.1.

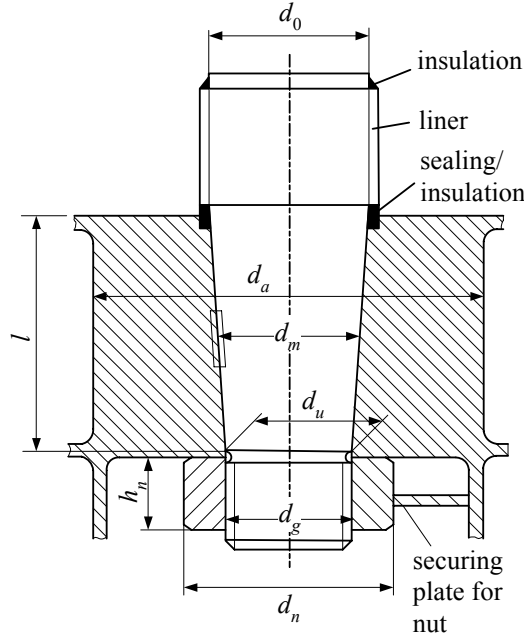

Figure 4.4.1 Cone coupling with key

4.4.2 The coupling length ℓ is to be, in general, not less than $1.5d_0$.

4.4.3 For couplings between stock and rudder a key is to be provided, the shear area of which is not to be less than:

$$a_s = \frac{17.55Q_F}{d_k R_{eH1}}, \text{ [cm}^2\text{]} \quad (4.4.3)$$

where:

Q_F – design yield moment of rudder stock according to Chapter 6, [Nm];

d_k – diameter of the conical part of the rudder stock at the key, [mm];

R_{eH1} – minimum yield stress of the key material, [N/mm²].

4.4.4 The effective surface area of the key (without rounded edges) between key and rudder stock or cone coupling is not to be less than:

$$a_k = \frac{5Q_F}{d_k R_{eH2}}, \text{ [cm}^2\text{]} \quad (4.4.4)$$

where:

R_{eH2} – minimum yield stress of the key, stock or coupling material, whichever is less, [N/mm²].

4.4.5 The dimensions of the slugging nut are to be as follows (see Fig 4.4.1):

i) height: $h_n = 0.6d_g$, (4.4.5-1)

ii) outer diameter, the greater value of :

a) $d_n = 1.2 d_u$ (4.4.5-2a)

b) $d_n = 1.5 d_g$, (4.4.5-2b)

iii) external thread diameter: $d_g = 0.65 d_0$. (4.4.5-3)

4.4.6 It is to be proved that 50% of the design yield moment will be solely transmitted by friction in the cone couplings. This can be done by calculating the required push-up pressure and push-up length according to 4.5.3 for a torsional moment $Q'_F = 0.5Q_F$.

4.5 Cone couplings with special arrangements for mounting and dismounting the couplings

4.5.1 Where the stock diameter exceeds 200 mm, the press fit is recommended to be effected by a hydraulic pressure connection. In such cases the cone is to be more slender, $c \approx 1:12$ to $\approx 1:20$.

4.5.2 In case of hydraulic pressure connections the nut is to be effectively secured against the rudder stock or the pintle. A securing plate for securing the nut against the rudder body is not to be provided (see Fig 4.5.2).

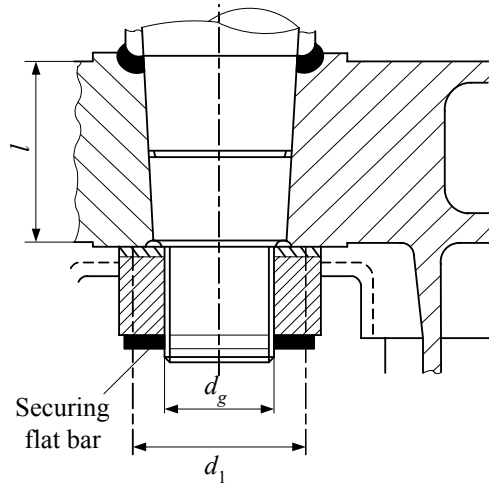

Figure 4.5.2 Cone coupling without key

Note: A securing flat bar will be regarded as an effective securing device of the nut, if its shear area is not less than:

$$A_s = \frac{P_s \cdot \sqrt{3}}{R_{eH}}, \text{ [mm}^2\text{]} \quad (4.5.2)$$

where:

P_s – shear force, as follows:

$$P_s = \frac{P_e}{2} \mu_1 \left(\frac{d_1}{d_g} - 0.6 \right), \text{ [N]} \quad (4.5.3)$$

P_e – push-up force according to 4.5.5, [N];

μ_1 – frictional coefficient between nut and rudder body, normally $\mu_1 = 0.3$;

d_1 – mean diameter of the frictional area between nut and rudder body, [mm];

d_g – thread diameter of the nut, [mm];

R_{eH} – minimum yield stress of the securing flat bar material, [N/mm²].

4.5.3 Push-up pressure and push-up length

For the safe transmission of the torsional moment by the coupling between rudder stock and rudder body the push-up length and the push-up pressure are to be determined according to 4.5.4 and 4.5.5.

4.5.4 Push-up pressure

The push-up pressure is not to be less than the greater of the two following values:

$$p_{reg1} = \frac{2Q_F}{d_m^2 \ell \pi \mu_0} 10^3, \text{ [N/mm}^2\text{]} \quad (4.5.4-1a)$$

$$p_{reg2} = \frac{6M_b}{\ell^2 d_m} 10^3, \text{ [N/mm}^2\text{]} \quad (4.5.4-1b)$$

where:

Q_F – design yield moment of rudder stock according to Chapter 6, [Nm];

d_m – mean cone diameter, [mm];

ℓ – cone length, [mm];

μ_0 – frictional coefficient, equal to about 0.15;

M_b – bending moment in the cone coupling (e.g. in case of spade rudders), [Nm].

It has to be proved that the push-up pressure does not exceed the permissible surface pressure in the cone. The permissible surface pressure is to be determined by the following formula:

$$p_{perm} = \frac{0.8R_{eH}(1-\alpha^2)}{\sqrt{3+\alpha^4}}, \text{ [N/mm}^2\text{]} \quad (4.5.4-2)$$

where:

R_{eH} – minimum yield stress of the material of the gudgeon, [N/mm²];

$$\alpha = \frac{d_m}{d_a} \quad (4.5.4-3)$$

d_m – diameter, as defined in Fig 4.5.2, [mm];

d_a – outer diameter of the gudgeon (see Fig 4.5.2), to be not less than $1.5d_m$, [mm].

4.5.5 Push-up length

The push-up length is not to be less than:

$$\Delta\ell_1 = \frac{p_{reg} d_m}{E \left(\frac{1-\alpha^2}{2} \right) c} + \frac{0.8R_{tm}}{c}, \text{ [mm]} \quad (4.5.5-1)$$

R_{tm} – mean roughness, taken equal to about 0.01, [mm];

c – taper on diameter according to 4.5.1;

α – as defined in 2.1.2.

The push-up length is, however, not to be taken greater than:

$$\Delta\ell_2 = \frac{1.6R_{eH} d_m}{Ec\sqrt{3+\alpha^4}} + \frac{0.8R_{tm}}{c}, \text{ [mm]} \quad (4.5.5-2)$$

Note: In case of hydraulic pressure connections the required push-up force P_e for the cone may be determined by the following formula:

$$P_e = p_{reg} d_m \pi \cdot \ell \left(\frac{c}{2} + 0.02 \right), \text{ [N]} \quad (4.5.5-3)$$

The value 0.02 is a reference for the friction coefficient using oil pressure. It varies and depends on the mechanical treatment and roughness of the details to be fixed.

Where due to the fitting procedure a partial push-up effect caused by the rudder weight is given, this may be taken into account when fixing the required push-up length, subject to approval by PRS.

4.5.6 Push-up pressure for pintle bearings

The required push-up pressure for pintle bearings is to be determined by the following formula:

$$p_{reg} = 0.4 \frac{B_1 d_0}{d_m^2 \ell}, \text{ [N/mm}^2\text{]} \quad (4.5.6)$$

where:

B_1 – supporting force in the pintle bearing (see Fig 3.3.3-3), [N];

d_m, ℓ – as defined in 4.5.3;

d_0 – pintle diameter according to Fig 4.4.1, [mm].

5 RUDDER BODY, RUDDER BEARINGS

5.1 Strength of rudder body

5.1.1 The rudder body is to be stiffened by horizontal and vertical webs in such a manner that the rudder body will be effective as a beam. The rudder should be additionally stiffened at the aft edge.

5.1.2 The strength of the rudder body is to be proved by direct calculation according to 3.3.

5.1.3 For rudder bodies without cut-outs the permissible stress are limited to:

i) bending stress due to M_R defined in 3.3.3:

$$\sigma_b = 110 \text{ N/mm}^2$$

ii) shear stress, in N/mm^2 , due to Q_1 defined in 3.3.3:

$$\tau = 50 \text{ N/mm}^2$$

iii) equivalent stress due to bending and shear:

$$\sigma_v = \sqrt{\sigma_b^2 + 3\tau^2} = 120$$

In case of openings in the rudder plating for access to cone coupling or pintle nut the permissible stresses according to 5.1.4 apply. Smaller permissible stress values may be required if the corner radii are less than $0.15h_0$, where h_0 is the height of opening.

5.1.4 In rudder bodies with cut-outs (semi-spade rudders) the following stress values are not to be exceeded:

i) bending stress due to M_R :

$$\sigma_b = 90 \text{ N/mm}^2$$

ii) shear stress, N/mm^2 , due to Q_1 :

$$\tau = 50 \text{ N/mm}^2$$

iii) torsional stress due to M_t :

$$\tau_t = 50 \text{ N/mm}^2$$

iv) equivalent stress due to bending and shear and equivalent stress due to bending and torsion:

$$\sigma_{v1} = \sqrt{\sigma_b^2 + 3\tau^2} = 120 / \text{mm}^2$$

$$\sigma_{v2} = \sqrt{\sigma_b^2 + 3\tau_t^2} = 100 / \text{mm}^2$$

where:

$$M_R = C_{R2} f_1 + B_1 \frac{f_2}{2}, \text{ [Nm]} \quad (5.1.4-1)$$

$$Q_1 = C_{R2}, \text{ [N]} \quad (5.1.4-2)$$

f_1, f_2 – as defined in Fig 5.1.4;

τ_t – torsional stress, in, taken equal to:

$$\tau_t = \frac{M_t}{2\ell ht}, \text{ [N/mm}^2\text{]} \quad (5.1.4-3)$$

$$M_t = C_{R2}e, \text{ [Nm]} \quad (5.1.4-4)$$

C_{R2} – partial rudder force of the partial rudder area A_2 below the cross section under consideration, [N];
 e – lever for torsional moment, [m], (horizontal distance between the centre of pressure of area A_2 and the centre line a-a of the effective cross sectional area under consideration, see Fig 5.1.4. The centre of pressure is to be assumed at $0.33c_2$ aft of the forward edge of area A_2 , where c_2 is the mean breadth of area A_2);

h, ℓ, t – dimensions, as defined in Fig 5.1.4, [cm].

The distance ℓ between the vertical webs should not exceed $1.2h$.

The radii in the rudder plating are not to be less than 4 to 5 times the plate thickness, but in no case less than 50 mm.

Note: It is recommended to keep the natural frequency of the fully immersed rudder and of local structural components at least 10 % above the exciting frequency of the propeller (number of revolutions \times number of blades) or if relevant above higher order

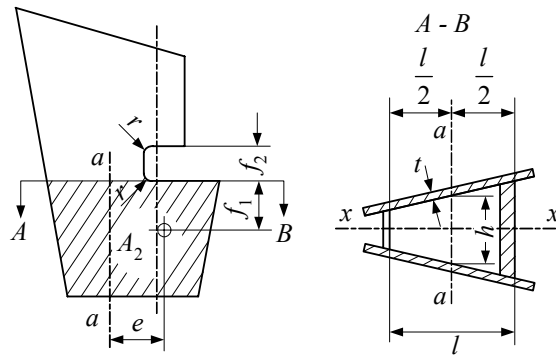

Figure 5.1.4 Geometry of rudder

5.2 Rudder plating

5.2.1 The thickness of the rudder plating is to be determined according to the following formula:

$$t_p = 1.74a\beta\sqrt{p_R k} + 2.5, \text{ [mm]} \quad (5.2.1-1)$$

where:

$$p_R = 10T + \frac{C_R}{10^3 A}, \text{ [kN/m}^2\text{]} \quad (5.2.1-2)$$

$$\beta = \sqrt{1.1 - 0.5\left(\frac{a}{b}\right)^2} \quad (5.2.1-3)$$

Note: $\beta_{\max} = 1.00$, if $\frac{b}{a} \geq 2.5$;

a – smaller unsupported width of a plate panel, [m];

b – greatest unsupported width of a plate panel, [m].

However, the thickness is to be not less than the thickness of the shell plating at aft part according to Common Structural Rules, Pt 1, Ch 6, Sec 3.

Regarding dimensions and welding, 10.1.1 is to be complied with.

5.2.2 For connecting the side plating of the rudder to the webs tenon welding is not to be used. Where application of fillet welding is not practicable, the side plating is to be connected by means of slot welding to flat bars which are welded to the webs.

5.2.3 The thickness of the webs, in mm, is not to be less than 70 % of the thickness of the rudder plating according to 5.2.1, but not less than:

$$t_{\min} = 8\sqrt{k}, \text{ [mm]} \quad (5.2.3)$$

Webs exposed to seawater are to be dimensioned according to 5.2.1.

5.3 Connections of rudder blade structure with solid parts in forged or cast steel

5.3.1 General

Solid parts in forged or cast steel which ensure the housing of the rudder stock or of the pintle are in general to be connected to the rudder structure by means of two horizontal web plates and two vertical web plates.

5.3.2 Minimum section modulus of the connection with the rudder stock housing

The section modulus of the cross-section of the structure of the rudder blade which is connected with the solid part where the rudder stock is housed, which is made by vertical web plates and rudder plating, is to be not less than that obtained from the following formula:

$$w_s = c_s d_1^3 \left(\frac{H_E - H_X}{H_E} \right)^2 \frac{k}{k_1} 10^{-4}, \text{ [cm}^3\text{]} \quad (5.3.2)$$

where:

c_s - coefficient, to be taken equal to:

$c_s = 1.0$ if there is no opening in the rudder plating or if such openings are closed by a full penetration welded plate,

$c_s = 1.5$ if there is an opening in the considered cross-section of the rudder;

D_1 - rudder stock diameter defined in 3.2.1, [mm];

H_E - vertical distance between the lower edge of the rudder blade and the upper edge of the solid part, [m];

H_X - vertical distance between the considered cross-section and the upper edge of the solid part, [m];

k, k_1 - material factors, defined for the rudder blade plating and the rudder stock, respectively.

5.3.3 Calculation of the actual section modulus of the connection with the rudder stock housing

The actual section modulus of the cross-section of the structure of the rudder blade which is connected with the solid part where the rudder stock is housed is to be calculated with respect to the symmetrical axis of the rudder.

The breadth of the rudder plating to be considered for the calculation of this actual section modulus is to be not greater than that obtained from the following formula:

$$b = s_v + 2 \frac{H_X}{m}, \text{ [m]} \quad (5.3.3)$$

where:

s_v - spacing between the two vertical webs (see Fig 5.3.3), [m];

H_X - distance defined in 5.3.2;

m - coefficient to be taken, in general, equal to 3.

Where openings for access to the rudder stock nut are not closed by a full penetration welded plate, they are to be deducted (see Fig 5.3.3).

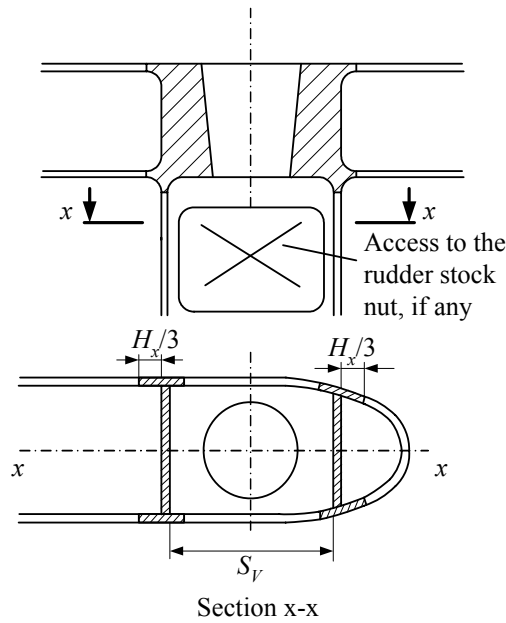

Figure 5.3.3 Cross-section of the connection between rudder blade structure and rudder stock housing

5.3.4 Thickness of horizontal web plates

In the vicinity of the solid parts, the thickness of the horizontal web plates, as well as that of the rudder blade plating between these webs, is to be not less than the greater of the values obtained from the following formulae:

$$t_H = 1.2t_p, \text{ [mm]} \quad (5.3.4-1a)$$

$$t_H = 0.045 \frac{d_S^2}{S_H}, \text{ [mm]} \quad (5.3.4-1b)$$

where:

t_p – defined in 5.2.1;

d_S – diameter, to be taken equal to:

$$d_S = D_1, \text{ [mm]} \quad (5.3.4-2)$$

for the solid part connected to the rudder stock,

$$d_S = d_a, \text{ [mm]} \quad (5.3.4-3)$$

for the solid part connected to the pintle;

D_1 – rudder stock diameter defined in 3.2.1, [mm];

d_a – pintle diameter defined in 5.5.1, [mm];

S_H – spacing between the two horizontal web plates, [mm].

Different thickness may be accepted when justified on the basis of direct calculations submitted to PRS for approval.

5.3.5 Thickness of side plating and vertical web plates welded to the solid part

The thickness of the vertical web plates welded to the solid part where the rudder stock is housed as well as the thickness of the rudder side plating under this solid part is to be not less than the values obtained, in mm, from Tab 5.3.5.

Table 5.3.5
Thickness of side plating and vertical web plates

Type of rudder	Thickness of vertical web plates, [mm]		Thickness of rudder plating, [mm]	
	Rudder blade without opening	At opening boundary	Rudder blade without opening	Area with opening
Rudder supported by sole piece (Fig 3.3.3-1)	$1.2t_p$	$1.6t_p$	$1.2t_p$	$1.4t_p$
Semi-spade and spade rudders (Fig 3.3.3-2 to Fig 3.3.3-5)	$1.4t_p$	$2.0t_p$	$1.3t_p$	$1.6t_p$
t_p - defined in 5.2.1.				

5.3.6 Solid part protrusions

The solid parts are to be provided with protrusions. Vertical and horizontal web plates of the rudder are to be butt welded to these protrusions.

These protrusions are not required when the web plate thickness is less than:

- i) 10 mm for web plates welded to the solid part on which the lower pintle of a semi-spade rudder is housed and for vertical web plates welded to the solid part of the rudder stock coupling of spade rudders,
- ii) 20 mm for the other web plates.

5.3.7 If the torque is transmitted by a prolonged shaft extended into the rudder, the latter must have the diameter D_t or D_1 , whichever is greater, at the upper 10 % of the intersection length. Downwards it may be tapered to $0.6D_t$, in spade rudders to 0.4 times the strengthened diameter, if sufficient support is provided for.

5.4 Rudder bearings

5.4.1 In way of bearings liners and bushes are to be fitted.

Their minimum thickness is equal to:

- i) $t_{min} = 8$ mm for metallic materials and synthetic material,
- ii) $t_{min} = 22$ mm for lignum material.

Where in case of small ships bushes are not fitted, the rudder stock is to be suitably increased in diameter in way of bearings enabling the stock to be re-machined later.

5.4.2 An adequate lubrication is to be provided.

5.4.3 The bearing forces result from the direct calculation mentioned in 3.3. As a first approximation the bearing force may be determined without taking account of the elastic supports. This can be done as follows:

- i) normal rudder with two supports:

The rudder force C_R is to be distributed to the supports according to their vertical distances from the centre of gravity of the rudder area.

- ii) semi-spade rudders:

support force in the rudder horn:

$$B_1 = C_R \frac{b}{c}, \text{ [N]} \quad (5.4.3-1)$$

support force in the neck bearing:

$$B_2 = C_R - B_1, \text{ [N]} \quad (5.4.3-2)$$

For b and c see Fig 9.2.1-1.

5.4.4 The projected bearing surface A_b (“bearing height” × “external diameter of liner”) is not to be less than:

$$A_b = \frac{B}{q}, \text{ [mm}^2\text{]} \quad (5.4.4)$$

where:

B – support force, [N];

q – permissible surface pressure according to Tab 5.4.6.

5.4.5 Stainless and wear resistant steels, bronze and hot-pressed bronze-graphit materials have a considerable difference in potential to non-alloyed steel. Respective preventive measures are required.

5.4.6 The bearing height is to be equal to the bearing diameter, however, is not to exceed 1.2 times the bearing diameter. Where the bearing depth is less than the bearing diameter, higher specific surface pressures may be allowed.

Table 5.4.6
Surface pressure q of bearing materials

Bearing material	q , [N/mm ²]
Lignum vitae	2.5
White metal, oil lubricated	4.5
Synthetic material ⁽¹⁾	5.5
Steel ⁽²⁾ , bronze and hot-pressed bronze-graphite materials	7.0
⁽¹⁾ Synthetic materials to be of approved type. Surface pressures exceeding 5.5 N/mm ² may be accepted in accordance with bearing manufacturer's specification and tests, but in no case more than 10 N/mm ² . ⁽²⁾ Stainless and wear resistant steel in an approved combination with stock liner. Higher surface pressures than 7 N/mm ² may be accepted if verified by tests.	

The wall thickness of pintle bearings in sole piece and rudder horn is to be approximately equal to one fourth of the pintle diameter.

5.5 Pintles

5.5.1 Pintles are to have scantlings complying with the conditions given in 4.4 and 4.6. The pintle diameter is not to be less than:

$$d_a = 0.35\sqrt{B_1 k_r}, \text{ [mm]} \quad (5.5.1)$$

where:

B_1 - support force, [N];

k_r - material factor defined in 1.4.2.

5.5.2 The thickness of any liner or bush is neither to be less than:

$$t = 0.01\sqrt{B_1}, \text{ [mm]} \quad (5.5.2)$$

nor than the minimum thickness defined in 10.1.5.4.1.

5.5.3 Where pintles are of conical shape, the taper on diameter is to comply with the following:

- i) 1:8 to 1:12, if keyed by slugging nut,
- ii) 1:12 to 1:20, if mounted with oil injection and hydraulic nut.

5.5.4 The pintles are to be arranged in such a manner as to prevent unintentional loosening and falling out. For nuts and threads the requirements of 4.4.5 and 4.5.2 apply accordingly.

5.6 Criteria for bearing clearances

5.6.1 For metallic bearing material the bearing clearance is to be not less:

$$\frac{d_b}{1000} + 1.0, \text{ [mm]} \quad (5.6.1)$$

where:

d_b – inner diameter of bush, [mm].

5.6.2 If non-metallic bearing material is applied, the bearing clearance is to be specially determined considering the material's swelling and thermal expansion properties.

5.6.3 The clearance is not to be taken less than 1.5 mm on diameter. In case of self lubricating bushes going down below this value can be agreed to on the basis of the manufacturer's specification.

6 DESIGN YIELD MOMENT OF RUDDER STOCK

6.1 General

6.1.1 The design yield moment of the rudder stock is to be determined by the following formula:

$$Q_F = 0.02664 \frac{D_t^3}{k_r}, \text{ [Nm]} \quad (6.1.1)$$

D_t – stock diameter according to 3.1, [mm].

Where the actual diameter D_{ta} is greater than the calculated diameter D_t , the diameter D_{ta} is to be used. However, D_{ta} applied to the above formula need not be taken greater than $1.145D_t$.

7 STOPPER, LOCKING DEVICE

7.1 Stopper

7.1.1 The motions of quadrants or tillers are to be limited on either side by stoppers. The stoppers and their foundations connected to the ship's hull are to be of strong construction so that the yield point of the applied materials is not exceeded at the design yield moment of the rudder stock.

7.2 Locking device

7.2.1 Each steering gear is to be provided with a locking device in order to keep the rudder fixed at any position. This device as well as the foundation in the ship's hull are to be of strong construction so that the yield point of the applied materials is not exceeded at the design yield moment of the rudder stock as specified in Chapter 6. Where the ship's speed exceeds 12 knots, the design yield moment need only be calculated for a stock diameter based on a speed $V_0 = 12$ knots.

7.3 Stopper and locking device

7.3.1 Regarding stopper and locking device see also the applicable requirements of PRS Rules for the Classification and Construction of Sea-going Ships, *Part VII - Machinery, Boilers and Pressure Vessels*.

8 PROPELLER NOZZLES

8.1 General

8.1.1 The following requirements are applicable to propeller nozzles having an inner diameter of up to 5 m. Nozzles with larger diameters will be specially considered.

8.1.2 Special attention is to be given to the support of fixed nozzles at the hull structure.

8.2 Design pressure

8.2.1 The design pressure for propeller nozzles is to be determined by the following formula:

$$p_d = cp_{d0}, \text{ [kN/m}^2\text{]} \quad (8.2.1-1)$$

where:

$$p_{d0} = \varepsilon \frac{N}{A_p}, \text{ [kN/m}^2\text{]} \quad (8.2.1-2)$$

N – maximum shaft power, [kW];

A_p – propeller disc area, taken equal to:

$$A_p = D^2 \frac{\pi}{4}, \text{ [m}^2\text{]} \quad (8.2.1-3)$$

D – propeller diameter, [m];

ε – factor obtained from the following formula:

$$\varepsilon = 0.21 - 2 \cdot 10^{-4} \frac{N}{A_p}, \text{ without being taken less than } 0.1 \quad (8.2.1-4)$$

c – coefficient taken equal to (see Fig 8.2.1):

$c = 1.0$ in zone 2 (propeller zone),

$c = 0.5$ in zones 1 and 3,

$c = 0.35$ in zone 4.

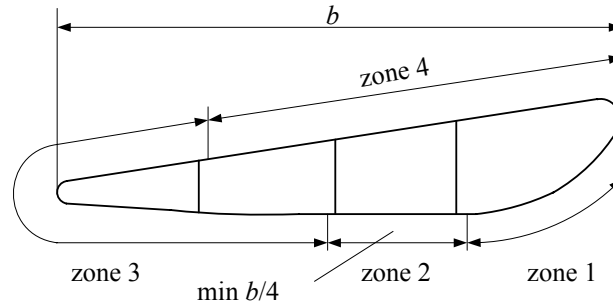

Figure 8.2.1 Zones of propeller nozzle

8.3 Plate thickness

8.3.1 The thickness of the nozzle shell plating, in mm, is not to be less than:

$$t = t_0 + t_k, \text{ [mm]} \quad (8.3.1-1)$$

where:

t_0 – thickness, in mm, obtained from the following formula:

$$t_0 = 5a\sqrt{p_d}, \text{ [mm]} \quad (8.3.1-2)$$

a – spacing of ring stiffeners, [m];

t_k – corrosion allowance, taken equal to:

$$t_k = 1.5, \text{ [mm]} \text{ if } t_0 \leq 10 \quad (8.3.1-3)$$

$$t_k = \min \left[0.1 \left(\frac{t_0}{\sqrt{k}} + 0.5 \right), 3.0 \right], \text{ [mm]} \text{ if } t_0 > 10 \quad (8.3.1-4)$$

8.3.2 The web thickness of the internal stiffening rings is not to be less than the nozzle plating for zone 3, however, in no case be less than 7.5 mm.

8.4 Section modulus

8.4.1 The section modulus of the cross section shown in Fig 8.2.1 around its neutral axis is not to be less than:

$$w = nd^2bV_0^2, \text{ [cm}^3\text{]} \quad (8.4.1)$$

where:

- d – inner diameter of nozzle, [m];
- b – length of nozzle, [m];
- n – coefficient taken equal to:
 - $n = 1.0$, for rudder nozzles,
 - $n = 0.7$, for fixed nozzles.

8.5 Welding

8.5.1 The inner and outer nozzle shell plating is to be welded to the internal stiffening rings as far as practicable by double continuous welds. Plug welding is only permissible for the outer nozzle plating.

9 RUDDER HORN AND SOLE PIECE SCANTLINGS

9.1 Sole piece

9.1.1 The section modulus of the sole piece related to the z -axis, in, is not to be less than:

$$W_z = \frac{B_1 x k}{80}, \text{ [cm}^3\text{]} \quad (9.1.1-1)$$

where:

- B_1 – as defined in 3.3. For rudders with two supports the support force is approximately $B_1 = C_R/2$, when the elasticity of the sole piece is ignored.
- x – distance of the respective cross section from the rudder axis, with:
 - $x_{\min} = 0.5 \ell_{50}$, [m] (9.1.1-2)
 - $x_{\max} = \ell_{50}$, [m] (9.1.1-3)
- ℓ_{50} – as defined in 3.3.2 and Fig 9.1.1.

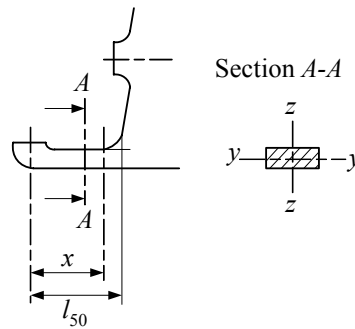

Figure 9.1.1 Sole piece

9.1.2 The section modulus related to the y -axis is not to be less than:

- i) where no rudder post or rudder axle is fitted

$$W_y = \frac{W_z}{2}, \text{ [cm}^3\text{]} \quad (10.1.9.1.2-1)$$

- ii) where a rudder post or rudder axle is fitted

$$W_y = \frac{W_z}{3}, \text{ [cm}^3\text{]} \quad (10.1.9.1.2-2)$$

9.1.3 The sectional area at the location $x = \ell_{50}$ is not to be less than:

$$A_s = \frac{B_1}{48} k, \text{ [mm}^2\text{]} \quad (10.1.9.1.3)$$

9.1.4 The equivalent stress taking into account bending and shear stresses at any location within the length ℓ_{50} is not to exceed:

$$\sigma_v = \sqrt{\sigma_b^2 + 3\tau^2} = \frac{115}{k}, \text{ [N/mm}^2\text{]} \quad (10.1.9.1.4-1)$$

where:

$$\sigma_b = \frac{B_1 x}{W_z}, \text{ [N/mm}^2\text{]} \quad (10.1.9.1.4-2)$$

$$\tau = \frac{B_1}{A_s}, \text{ [N/mm}^2\text{]} \quad (10.1.9.1.4-3)$$

9.2 Rudder horn of semi spade rudders (case of 1-elastic support)

9.2.1 The distribution of the bending moment, shear force and torsional moment is to be determined according to the following formulae:

i) bending moment: $M_b = B_1 z, \text{ [Nm]} \quad (9.2.1-1)$

$$M_{bmac} = B_1 d, \text{ [Nm]} \quad (9.2.1-2)$$

ii) shear force: $Q = B_1, \text{ [N]} \quad (9.2.1-3)$

iii) torsional moment: $M_T = B_1 e_{(z)}, \text{ [Nm]} \quad (9.2.1-4)$

For determining preliminary scantlings the flexibility of the rudder horn may be ignored and the supporting force B_1 be calculated according to the following formula:

$$B_1 = C_R \frac{b}{c}, \text{ [N]} \quad (9.2.1-5)$$

where $b, c, d, e_{(z)}$ and z are defined in Fig 9.2.1.-1 and Fig 9.2.1.-2. b results from the position of the centre of gravity of the rudder area.

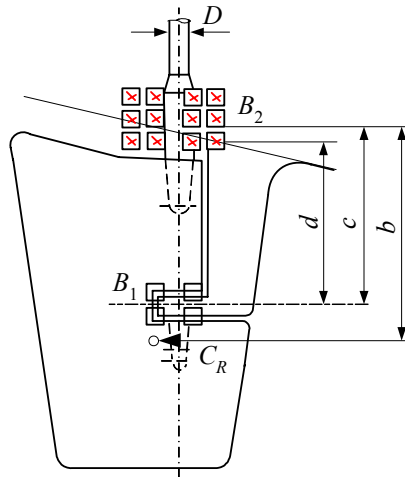

Figure 9.2.1.-1 Dimensions of rudder horn

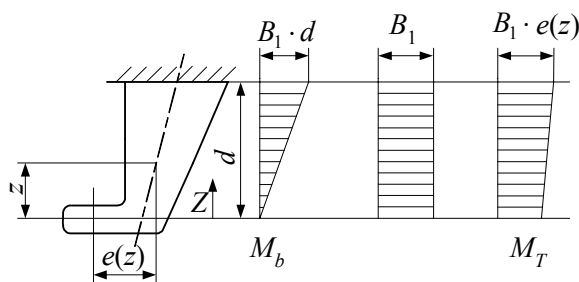

Figure 9.2.1-2 Rudder horn loads

9.2.2 The section modulus of the rudder horn in transverse direction related to the horizontal x -axis is - at any location z - not to be less than:

$$W_x = \frac{M_b k}{67}, \text{ [cm}^3\text{]} \quad (9.2.2)$$

9.2.3 At no cross section of the rudder horn the shear stress due to the shear force Q is to exceed the value:

$$\tau = \frac{48}{k}, \text{ [N/mm}^2\text{]} \quad (9.2.3-1)$$

The shear stress is to be determined by the following formula:

$$\tau = \frac{B_1}{A_h}, \text{ [N/mm}^2\text{]} \quad (9.2.3-2)$$

where:

A_h – effective shear area of the rudder horn in y -direction, [mm²].

9.2.4 The equivalent stress at any location z of the rudder horn is not to exceed the following value:

$$\sigma_v = \sqrt{\sigma_b^2 + 3(\tau^2 + \tau_T^2)} = \frac{120}{k}, \text{ [N/mm}^2\text{]} \quad (9.2.4-1)$$

where:

$$\sigma_b = \frac{M_b}{W_x}, \text{ [N/mm}^2\text{]} \quad (9.2.4-2)$$

$$\tau_T = \frac{M_T}{2A_T t_h} \cdot 10^3, \text{ [N/mm}^2\text{]} \quad (9.2.4-3)$$

A_T – sectional area enclosed by the rudder horn at the location considered, [mm²];

t_h – thickness of the rudder horn plating, [mm].

9.2.5 When determining the thickness of the rudder horn plating the provisions of 5.2 to 5.4 are to be complied with. The thickness is, however, not to be less than $2.4\sqrt{Lk}$ mm.

9.2.6 The rudder horn plating is to be effectively connected to the aft ship structure, e.g. by connecting the plating to longitudinal girders, in order to achieve a proper transmission of forces, see Fig 9.2.6.

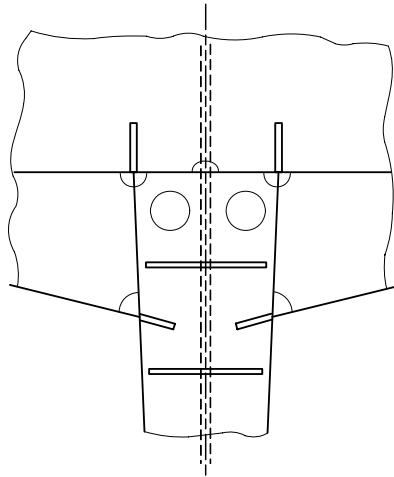

Figure 9.2.6 Connection of rudder horn to aft ship structure

9.2.7 Transverse webs of the rudder horn are to be led into the hull up to the next deck in a sufficient number and must be of adequate thickness.

9.2.8 Strengthened plate floors are to be fitted in line with the transverse webs in order to achieve a sufficient connection with the hull. The thickness of these plate floors is to be increased by 50% above the bottom thickness determined according to Common Structural Rules, Pt 1, Ch 6, Sec 3 and 4.

9.2.9 The centre line bulkhead (wash-bulkhead) in the after peak is to be connected to the rudder horn.

9.2.10 Where the transition between rudder horn and shell is curved, about 50% of the required total section modulus of the rudder horn is to be formed by the webs in a section A - A located in the centre of the transition zone, i.e. $0.7r$ above the beginning of the transition zone (see Fig. 9.2.10).

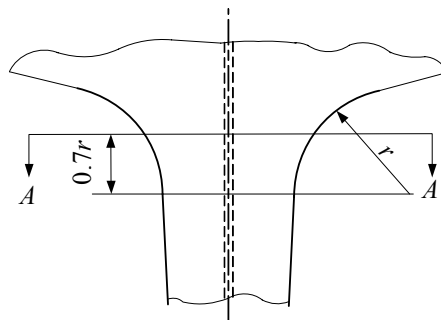

Figure 9.2.10 Transition between rudder horn and shell

9.3 Rudder horn of semi spade rudders (case of 2-conjugate elastic supports)

9.3.1 Bending moment

The bending moment acting on the generic section of the rudder horn is to be obtained from the following formulae:

i) between the lower and upper supports provided by the rudder horn:

$$M_H = F_{A1}z, \text{ [Nm]} \quad (9.3.1-1)$$

ii) above the rudder horn upper-support:

$$M_H = F_{A1}z + F_{A2}(z - d_{lu}), \text{ [Nm]} \quad (9.3.1-2)$$

where:

F_{A1} – support force at the rudder horn lower-support, to be obtained according to Fig 3.3.3-3, and taken equal to B_1 , [N];

- F_{A2} – support force at the rudder horn upper-support, to be obtained according to Fig 3.3.3-3, and taken equal to B_2 , [N];
- z – distance, [m], defined in Fig 9.3.3, to be taken less than the distance d , [m], defined in the same figure;
- d_{lu} – distance between the rudder-horn lower and upper bearings (according to Fig 9.3.1, $d_{lu} = d - \lambda$), [m].

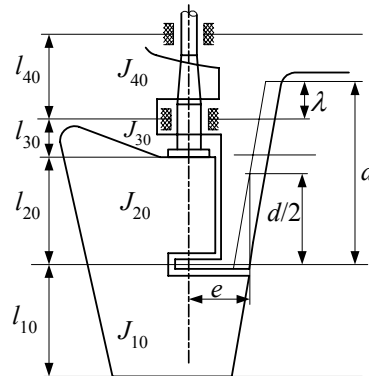

Figure 9.3.1 Geometrical parameters for the calculation of the bending moment in rudder horn

9.3.2 Shear force

The shear force Q_H acting on the generic section of the rudder horn is to be obtained from the following formulae:

- i) between the lower and upper rudder horn bearings:

$$Q_H = F_{A1}, \text{ [N]} \quad (9.3.2-1)$$

- ii) above the rudder horn upper-bearing:

$$Q_H = F_{A1} + F_{A2}, \text{ [N]} \quad (9.3.2-2)$$

where:

F_{A1}, F_{A2} – support forces, [N].

9.3.3 Torque

The torque acting on the generic section of the rudder horn is to be obtained from the following formulae:

- i) between the lower and upper rudder horn bearings:

$$M_T = F_{A1}e_{(x)}, \text{ [Nm]} \quad (9.3.3-1)$$

- ii) above the rudder horn upper-bearing:

$$M_T = F_{A1}e_{(x)} + F_{A2}e_{(x)}, \text{ [Nm]} \quad (9.3.3-2)$$

where:

F_{A1}, F_{A2} – support forces, [N];

$e_{(x)}$ – torsion lever defined in Fig 9.3.3, [m].

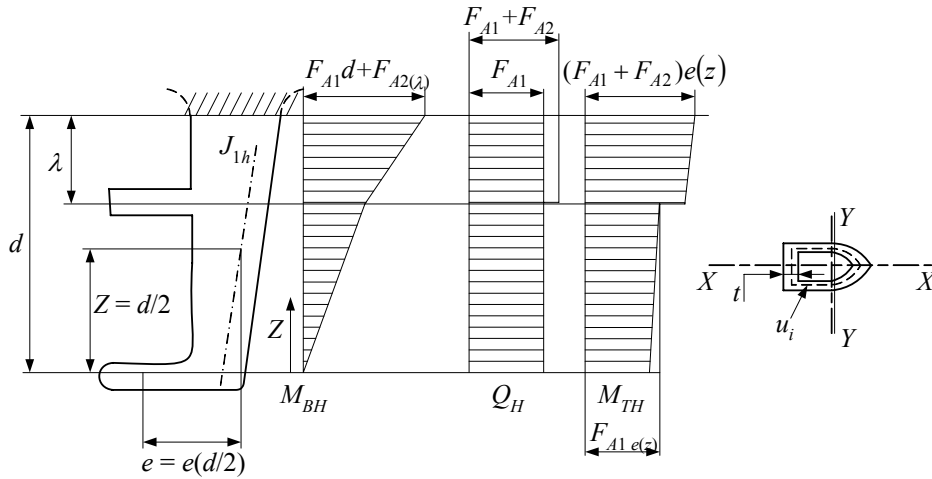

Figure 9.3.3 Geometry of rudder horn

9.3.4 Shear stress calculation

- 1 For a generic section of the rudder horn, located between its lower and upper bearings, the following stresses are to be calculated:

- i) τ_S - shear stress to be obtained from the following formula:

$$\tau_S = \frac{F_{A1}}{A_H}, \text{ [N/mm}^2\text{]} \quad (9.3.4.1-1)$$

- ii) τ_T - torsional stress to be obtained for hollow rudder horn from the following formula:

$$\tau_T = \frac{M_T 10^3}{2F_T t_H}, \text{ [N/mm}^2\text{]} \quad (9.3.4.1-2)$$

For solid rudder horn, τ_T is to be considered by PRS on a case by case basis;

- 2 For a generic section of the rudder horn, located in the region above its upper bearing, the following stresses are to be calculated:

- i) τ_S - shear stress to be obtained from the following formula:

$$\tau_S = \frac{F_{A1} + F_{A2}}{A_H}, \text{ [N/mm}^2\text{]} \quad (9.3.4.2-1)$$

- ii) τ_T - torsional stress to be obtained for hollow rudder horn from the following formula:

$$\tau_T = \frac{M_T 10^3}{2F_T t_H}, \text{ [N/mm}^2\text{]} \quad (9.3.4.2-2)$$

For solid rudder horn, τ_T is to be considered by PRS on a case by case basis.

where:

F_{A1}, F_{A2} – support forces, [N];

A_H – effective shear sectional area of the rudder horn in y -direction, [mm²];

M_T – torque, [Nm];

F_T – mean of areas enclosed by outer and inner boundaries of the thin walled section of rudder horn, [m²];

t_h – plate thickness of rudder horn, [mm]. For a given cross section of the rudder horn, the maximum value of τ_T is obtained at the minimum value of t_H .

9.3.5 Bending stress calculation

For the generic section of the rudder horn within the length d , defined in Fig 9.2.1-1, the following stresses are to be calculated:

σ_B – bending stress to be obtained from the following formula:

$$\sigma_B = \frac{M_H}{W_X}, \text{ [N/mm}^2\text{]} \quad (9.3.5)$$

M_H – bending moment at the section considered, [Nm];

W_X – section modulus around the X-axis (see Fig 9.3.3), [cm³].

9.3.6 General remarks

Requirements 9.2.5 to 9.2.10 also apply to rudder horn with 2-conjugate elastic supports.

10 RUDDER COUPLING FLANGES

10.1 Connections of rudder coupling flanges

10.1.1 Unless forged or cast steel flanges with integrally forged or cast welding flanges are used, horizontal rudder coupling flanges are to be joined to the rudder body by plates of graduated thickness and full penetration single or double-bevel welds as prescribed in Common Structural Rules Pt 1, Ch 12, Sec 1 (see Fig 10.1.1).

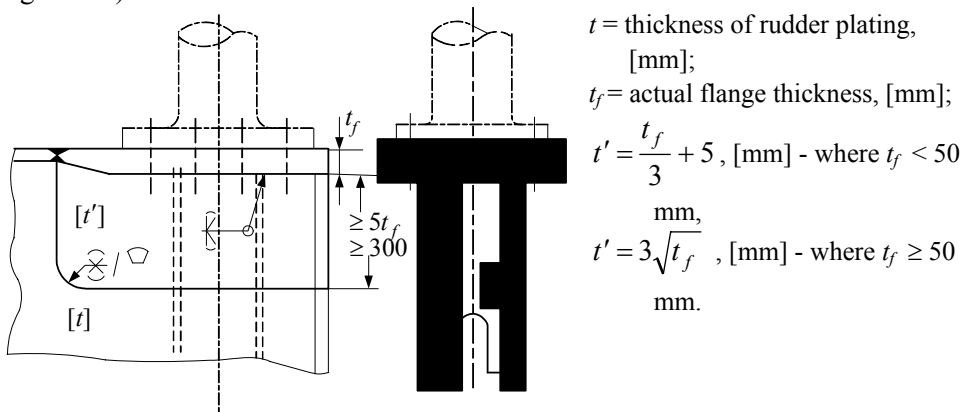

Figure 10.1.1 Horizontal rudder coupling flanges

10.1.2 Allowance is to be made for the reduced strength of the coupling flange in the thickness direction. In case of doubt, proof by calculation of the adequacy of the welded connection shall be produced.

10.1.3 The welded joint between the rudder stock (with thickened collar see Common Structural Rules Pt 1, Ch 12, Sec 2 and the flange is to be made in accordance with Fig 10.1.3.

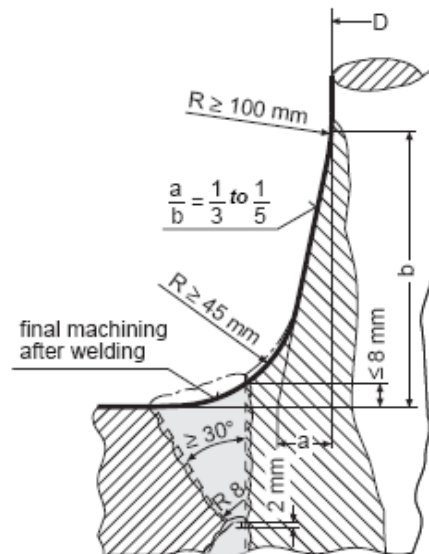

Figure 10.1.3 Welded joint between rudder stock and coupling flange