

Polski Rejestr Statków

RULES FOR THE CLASSIFICATION AND CONSTRUCTION OF NAVAL SHIPS

PART X STATUTORY EQUIPMENT

2008



GDAŃSK

RULES FOR THE CLASSIFICATION AND CONSTRUCTION OF NAVAL SHIPS

prepared and edited by Polski Rejestr Statków, hereinafter referred to as PRS, consist of the following Parts:

- Part I – Classification Regulations
- Part II – Hull
- Part III – Hull Equipment
- Part IV – Stability and Subdivision
- Part V – Fire Protection
- Part VI – Machinery Installations and Refrigerating Plants
- Part VII – Machinery, Boilers and Pressure Vessels
- Part VIII – Electrical Installations and Control Systems
- Part X – Statutory Equipment.

while with regard to materials and welding, the requirements of *Part IX – Materials and Welding of the Rules for the Classification and Construction of Sea-going Ships*, apply.

Part X – Statutory Equipment – 2008 was approved by the PRS Board on 24 June 2008 and enters into force on 1 August 2008.

From the entry into force, the requirements of *Part X – Statutory Equipment – 2008* apply to:

- new naval ships, for which the building contract will be signed on or after 1 August 2008 – within the full scope,
- existing naval ships, in accordance with principles specified in *Part I – Classification Regulations*.

The requirements of the present Rules are extended and supplemented by documents referred to in their individual Parts and, particularly, in NATO Standards, national standards and Polski Rejestr Statków Publications.

© Copyright by Polski Rejestr Statków S.A., 2008

PRS/AW, 09/2010

ISBN 978-83-7664-030-3

CONTENTS

	page
1 General	9
1.1 Application of the Requirements of the International Conventions in Naval Ship	9
1.2 Application	9
1.3 Definitions	10
1.4 Surveys and Issue of Documents Relating to the International Conventions.....	10
2 Requirements Relating to MARPOL 73/78 Convention	12
2.1 Annex I – Prevention of Pollution by Oil	12
2.2 Annex III – Prevention of Pollution by Harmful Substances Carried in Packaged Form	16
2.3 Annex IV – Prevention of Pollution by Sewage	18
2.4 Annex V – Prevention of Pollution by Garbage	21
2.5 Annex VI – Prevention of Air Pollution	24
3 Transient Requirements Relating to Solas Convention, Chapter III – Life-Saving Appliance and Arrangements	29
3.1 Application	29
3.2 Definitions	29
3.3 Technical Documentation of Life-saving Appliances for the New Ship	31
3.4 Technical Documentation of Life-saving Appliances for the Existing Ship Subject To Alteration Or Reconstruction.....	32
3.5 Life-saving Appliances for the New Ship.....	32
3.5.2 Radio Life-saving Appliances	32
3.5.3 Equipment for Ships up to 100 Gross Tonnage	33
3.5.4 Minesweepers/Mine Destroyers	34
3.5.5 Ships of 100 t to 600 t.....	36
3.5.6 Equipment of the Corvette Class Ship.....	37
3.5.7 Equipment of the Frigate Class Ship	39
3.5.8 Equipment of the Landing Craft Class Ship	41
3.5.9 Equipment of the Supply Vessel Class Ship.....	44
3.6 The Requirements for Life-saving Equipment.....	46
3.6.1 Inflatable Liferrafts	46
3.6.2 Canopied Reversible Liferrafts	46
3.6.3 Self-righting Liferrafts	47
3.6.4 Open Reversible Liferrafts.....	47
3.6.5 Fast Rescue Boats.....	51
3.6.6 Appliances for Launching Fast Rescue Boats	52
4 Requirements Relating to Solas Convention, Chapter IV – Radiocommunications	54
4.1 Application	54
4.2 Terms and Definitions	54
4.3 Scope of Supervision	55

4.4	General.....	56
4.5	Radio Equipment for Sea Area A1 (<i>acc. to SOLAS IV/8</i>)	58
4.6	Radio Equipment for Sea Areas A1 and A2 (<i>acc. to SOLAS IV/9</i>)	59
4.7	Radio Equipment for sea areas A1, A2 and A3 (<i>acc. to SOLAS IV/10</i>)	59
4.8	Radio Equipment for sea areas A1, A2, A3 and A4 (<i>acc. to SOLAS IV/11</i>).....	61
4.9	Sources of Energy (<i>acc. to SOLAS IV/13, except of 4.9.1, 4.9.2, 4.9.3</i>).....	61
4.10	Installation Requirements	63
4.10.1	Arrangement	63
4.10.2	Cable Network Installation	65
4.10.3	Earthing.....	65
4.10.4	Antennas	66
4.11	Performance Requirements for Radio Installations.....	69
4.11.1	General (<i>acc. to Res. A.694(17)</i>)	69
4.11.2	VHF Radio Installations for Voice and Digital Selective Calling DSC (<i>acc. to Res.A.803(19) and MSC.68(68), excluding 4.11.2.31</i>)	71
4.11.3	MF Radio Installations for Voice Communication and Digital Selective Calling DSC (<i>acc. to Res. A.804(19) and MSC.68(68)</i>) ...	75
4.11.4	MF/HF Radio Installations Capable of Voice Communication, Narrow-band Direct-printing NBDP, and Digital Selective Calling DSC (<i>acc. to Res. A.806(19) and MSC.68(68)</i>).....	79
4.11.5	Ship Earth Station for Satellite Communications INMARSAT.....	86
4.11.6	Enhanced Group Call Receiver EGC (<i>acc. to Res. A.664(16)</i>).....	87
4.11.7	Navigational and Meteorological Warnings Receiver NAVTEX (<i>acc. to Res. A.525(13)</i>).....	88
4.11.8	Float-Free Satellite Emergency Position-indicating Radio Beacon (EPIRB) Operating on 406 MHz (<i>acc. to Res. A.810(19), except of 4.11.8.5</i>).....	89
4.11.9	Radar Transponder SART (<i>acc. to Res. A.802(19)</i>)	91
4.11.10	Survival Craft Two-way VHF Radiotelephone Apparatus (<i>acc. to Res. A.809(19)</i>).....	93
4.11.11	Integrated Radiocommunication System IRCS (<i>acc. to Res. A.811(19)</i>).....	95
4.12	Shipborne Radio Installations Maintenance Requirements (<i>acc. to SOLAS IV/15</i>).....	96
4.13	Radio Personnel (<i>acc. to SOLAS IV/16</i>)	97
4.14	Radio Records	97
4.15	Position-updating	97
5	Requirements Relating to Solas Convention, chapter V – Safety of Navigation	98
5.1	Application	98
5.2	Definitions and Abbreviations	98
5.2.1	Definitions	98
5.2.2	Applied Abbreviations.....	99

5.3	Scope of Supervision	100
5.4	Carriage Requirements for Shipborne Navigational Systems And Equipment f or Ships Constructed on or after 1 July 2002 (SOLAS V/19))	102
5.5	Carriage Requirements for Shipborne Navigational Equipment on Ships Constructed before to 1 July 2002.....	105
5.5.1	Ships Constructed before 1 July 2002 shall.....	105
5.5.2	Magnetic Compasses (acc. to SOLAS V/12(b), 12(c)).....	105
5.5.3	Gyro-compasses (acc. to SOLAS V/12(d), 12(e)).....	106
5.5.4	Communication Means for Emergency Steering Position (acc. to SOLAS V /12(f)).....	106
5.5.5	Radars (acc. to SOLAS V/12(f)÷12(i)).....	107
5.5.6	Automatic Radar Plotting Aid (ARPA) (acc. to SOLAS V/12(j)).....	107
5.5.7	Echo-sounding Device (acc. to SOLAS V/12(k)).....	107
5.5.8	Speed and Distance Measurement Devices (acc. to SOLAS V/12(l))	108
5.5.9	Rate-of-turn Indicator (acc. to SOLAS V/12(n)).....	108
5.5.10	Nautical Publications (<i>acc. to SOLAS V/20</i>).....	108
5.5.11	Additional Equipment.....	108
5.6	Requirements for Installation and Power Supply of Navigational Equipment ..	108
5.6.1	General	108
5.6.2	Workstations in the Wheelhouse, their Arrangement and Reciprocal Dependence	109
5.6.3	Equipment Arrangement.....	110
5.6.4	Outfit of Particular Workstations.....	111
5.6.5	Requirements Concerning Particular Devices	113
5.6.6	Navigational Equipment Power Supply.....	117
5.6.7	Cable Network Installation.....	118
5.6.8	Navigational Equipment Earthing	118
5.7	Technical-operational Requirements for Navigational Equipment.....	119
5.7.1	General (acc. to Res. A.694(17)).....	119
5.7.2	Controls	119
5.7.3	Equipment Resistance to Power Supply Sources' Parameters Variations....	120
5.7.4	Durability and Resistance of the Equipment to External Exposures	120
5.7.5	Resistance of the Equipment to Interference	120
5.7.6	Means of Safety.....	121
5.7.7	Maintenance	121
5.7.8	Marking and Identification	122
5.7.9	Magnetic Compasses (acc. to Res. A.382(X)).....	122
5.7.10	Gyro-compasses (<i>acc. to Res. A.424(XI)</i>).....	126
5.7.11	Devices for Indication Speed and Distance (<i>acc. to Res. A.824(19), Res. MSC.96(72)</i>).....	127
5.7.12	Echo-sounding Equipment (<i>acc. to Res.A.224(VII), Res. MSC.74(69)</i>).....	129
5.7.13	Rate-of-turn Indicator (ROTI) (<i>acc. to Res. A.526(13)</i>)	130
5.7.14	Radars (acc. to Res. A.477(XII), Res. MSC.64(67) Annex 4).....	132

5.7.15	Navigational Information.....	138
5.7.16	Automatic Radar Plotting Aid (ARPA) (<i>acc. to Res. A.823(19)</i>)	138
5.7.17	Automatic Tracking Aid (ATA) (<i>Res. MSC.64(67) Annex 4</i>).....	145
5.7.18	Electronic Plotting Aid (EPA) (<i>Res. MSC.64(67) Aneks 4</i>).....	151
5.7.19	Electronic Chart Display and Information Systems (ECDIS)/Raster Chart display System (RCDS) (<i>acc. to Res. A.817(19), Res. MSC.64(67) Annex 5 i Res. MSC.86(70) Annex 4</i>).....	152
5.7.20	Back-Up ECDIS/RCDS Arrangements (<i>acc. to Res.MSC.64(67)</i>)	160
5.7.21	Naval Electronic Charts Display and Information System WECDIS ..	161
5.7.22	Daylight Signalling Lamp (<i>acc. to SOLAS 74, Ch.11</i>)	161
5.7.23	Global Positioning System (GPS) Receiver (<i>acc. to Res.A.819(19), Res.MSC.112(73)</i>).....	162
5.7.24	Combined Global Positioning System (GPS)/Global Navigation Satellite System (GLONASS) (<i>acc. to Res. MSC.74(69), Res.MSC.115(73)</i>)	164
5.7.25	Radio beacon receivers of the Differential Global Positioning System (DGPS) and the Differential Global Navigation Sattelite System (DGLONASS) (<i>acc. to Res.MSC.64(67), Res.MSC.114(73)</i>).	166
5.7.26	Automatic Identification System AIS (<i>acc. to Res. MSC.74(69)</i>).....	167
5.7.27	Voyage Data Recorded (VDR) (<i>acc. to Res. A.861(20)</i>)	170
5.7.28	Obtaining and Transmitting Magnetic Heading Device (TMHD) (<i>acc. to Res. MSC.86(70)</i>).....	173
5.7.29	Transmitting Heading Device (THD) (<i>acc. to Res. MSC.116(73)</i>).....	175
5.7.30	Sound Reception and Amplification System (<i>acc. to Res. MSC.86(70)</i>) .	176
5.7.31	Device for heading or tracking steering (<i>acc. to Res. A.342(IX), Res. MSC.64(67), Res. MSC.74(69)</i>).....	177
6	Requirements Relating to Solas Convention, Chapter VI – Carriage of Cargo	178
6.1	General.....	178
6.2	Definitions	178
6.3	Technical Documentation	178
6.4	Scope of Survey	179
6.5	General Requirements for the Stowage and Securing Devices	179
6.6	Stowing and Securing of Cargo Units.....	180
6.7	Calculations of Cargo Units' Securing	181
6.7.1	Determination of External Forces.....	181
6.7.2	Balancing of the Forces and Moments	183
7	Requirements Relating to Solas Convention, Chapter VII – Carriage of Dangerous Goods	185
7.1	General.....	185
7.1.1	Application	185
7.1.2	Definitions	185
7.2	Carriage Requirements.....	185
7.3	Documents	185

7.4	Carriage of Dangerous Goods.....	186
7.4.1	General Requirements	186
7.4.2	Specific Requirements.....	187
7.4.3	Document of Compliance.....	192
8	Requirements Related to International Regulations for Preventing Collisions at Sea (COLREG Convention).....	193
8.1	General.....	193
8.1.1	Application	193
8.1.2	Definitions and Descriptions	193
8.1.3	Range of Survey	194
8.1.4	Marking of Pyrotechnic Means	195
8.2	Equipment of Ships with Signalling Means.....	195
8.2.1	General	195
8.2.2	Outfit of Combat and Support Ships.....	197
8.2.3	Ships' Outfitting with Pyrotechnic Signal Means	198
8.3	Technical Requirements.....	198
8.3.1	Navigation Lights	198
8.3.2	General Technical Requirements.....	198
8.3.3	Lights Housing	201
8.3.4	Lenses.....	201
8.3.5	Colour Light Filters	202
8.3.6	Light Source	203
8.3.7	Signalling Lamps (acc. to SOLAS 74, chapter 11 and COLREG 72, Annex I, p. 12).....	204
8.4	Sound Signal Appliances – (acc. to COLREG 72, Annex. III, p.1).....	205
8.4.1	General	205
8.4.2	Whistles	205
8.4.3	Bell and Gong (acc. to COLREG 72, Annex III, p.2).....	206
8.4.4	Signal Shapes (acc. to COLREG 72, Annex I, p. 6 and Annex IV, p.1).	206
8.4.5	Pyrotechnic Signal Means (acc. to LSA Code, Chapter III).....	207
8.4.6	Radar Reflectors (acc. to Res. A.384(X)).....	208
8.5	Installation Requirements	211
8.5.1	General	211
8.5.2	Essential Lights on Combat and Support Ships (acc. to COLREG 72, Annex I, p. 2 a, b, c, d, e, f)	212
8.5.3	Signalling Lamps (acc. to SOLAS 74, Chapter V, reg. 11).....	214
8.5.4	Sound Signal Appliances (acc. to COLREG 72, Annex III, p. 1 a, b, c, d, e, f, g)	215
8.5.5	Devices for Hoisting and Storage of Signal Shapes	216
9	Requirements Relating to Load Lines Convention, LL 1966	217
9.1	General.....	217

10	Tonnage Certificates for Ships	218
10.1	General.....	218
10.2	Tonnage Certificates in Accordance with the International Convention on Tonnage Measurement of Ships, 1969, (TONNAGE 1969).....	219
10.3	Panama Canal Tonnage Certificate and Special Equipment.....	219
10.4	Suez Canal Special Tonnage Certificate.....	220
11	Survey of Statutory Equipment Manufacture	221
11.1	General.....	221
11.2	Direct Survey.....	221
11.3	Indirect Survey.....	221
11.4	Re-classification of Statutory Equipment.....	222
12	Approval of Testing Stations, Laboratories, Service Suppliers, Repair and Maintenance Workshops	223
12.1	General.....	223

1 GENERAL

1.1 Application of the requirements of the international conventions in naval ship

1.1.1 International Conventions listed in 1.2.5 are applicable to cargo and passenger ships, and every time specify the criteria for use of each of them.

1.1.2 It is advisable that non-commercial services of the state, as far as is reasonable and practicable, act in accordance with the provisions of international conventions in relation to operated by them naval or military auxiliary ships or other state vessels

1.1.3 The present Part X contains the requirements in accordance with technical requirements of relevant international Conventions, the current amendments to the Conventions and referred to by such conventions, as well as applicable codes and IMO resolutions.

1.1.4 Having the above in mind, the present Part X shall be considered as a recommendations to the naval ships, operating in a time of peace and being a subject of statutory supervision within the range specified by the customer.

1.2 Application

1.2.1 The present Part X sets out the requirements for equipment and systems for ensuring the safety of the ship and its crew, as well as and ensuring the protection of the marine environment.

1.2.2 The present Part X applies to the surface naval ships and auxiliary vessels.

1.2.3 In addition the present Part X applies to supply and logistic support vessels during carriage of specified cargoes, not constituting the vessel's stores.

1.2.4 In relation to high-speed crafts relevant chapters of International Code of Safety for High-Speed Craft apply. Application of the specified requirements of HSC Code shall be shall be preceded by technical and tactical-operational analysis for the given type of the ship.

1.2.5 The present Part X consist of the separate parts including requirements of:

- .1** International Convention for the Safety of Life at Sea, 1974 (SOLAS 1974);
- .2** International Convention on Load Lines, 1966 (LL 66);
- .3** International Convention for the Prevention of Pollution from Ships, 1973 (MARPOL 73/78);
- .4** International Convention on Tonnage Measurement of Ships, 1969 (TONNAGE 1969);
- .5** Convention on the International Regulations for Preventing Collisions at Sea, 1972 (COLREG 1972).

1.3 Definitions

1.3.1 Definitions concerning general terminology used in the *Rules for the Classification and Construction of Naval Ships* (hereinafter referred to as *the Rules*) are contained in *Part I – Classification Regulations*.

1.3.2 Detailed terms specific to the *Part X* and the terminology and topics of various chapters of the *Part X* are contained in the initial part of those chapters.

1.3.3 In the case of application in text of the *Part X* terms defined in the other parts of *the Rules*, relevant reference is given.

1.4 Surveys and issue of documents relating to the International Conventions

1.4.1 Polish Register of Shipping S.A. (hereinafter referred to as PRS), acting on the request and under authority of the Purchaser, performs technical supervision over statutory equipment by performance of the following surveys:

- the initial survey before the ship is put into service, aimed at a complete inspection of the structure and equipment to ensure that the relevant requirements are complied with, for the issue, for the first time, appropriate certificates of compliance;
- a periodical survey aimed at the inspection of a ship and its equipment relating to the particular certificates of compliance to ensure that they are in a satisfactory technical condition and are fit for service for which the ship is intended;
- a renewal survey which is the same as periodical survey but is aimed at the issue of new certificates of compliance;
- an intermediate survey aimed at inspection of specific items of a ship and its equipment relevant to the particular certificate of compliance, to ensure that they are in satisfactory condition and are fit for the service for which the ship is intended;
- an annual survey aimed at inspection of the ship and its equipment within the scope relating to the particular certificate of compliance to ensure that they have been maintained in accordance with the relevant requirements.
- an additional survey aimed at inspection, either general or partial according to the circumstances, to be made after damage, a repair resulting from execution of recommendations issued after a survey or whenever any important repairs or renewals are made.

1.4.2 In result of a technical supervision over the ships' equipment, PRS issues, renews and confirms Certificates of compliance documenting the fulfilment of the requirements of the Conventions and/or the Codes, to the extent specified in the Certificate of compliance relating to:

- .1 safety construction of the ship;
- .2 safety equipment of the ship;
- .3 safety radio of the ship;

- .4 load lines;
 - .5 exemptions from the requirements of load lines;
 - .6 oil pollution prevention;
 - .7 sewage pollution prevention;
 - .8 garbage pollution prevention;
 - .9 ships carrying dangerous goods;
 - .10 ships measurements.
-

2 REQUIREMENTS RELATING TO MARPOL 73/78 CONVENTION

2.1 Annex I – Prevention of pollution by oil

2.1.1 Definitions

- .1** Oil – petroleum in any form, including crude oil, fuel oil, sludge, oil refuse and refined products (other than petrochemicals which are subject to the provisions of *Annex II to MARPOL 73/78*)
- .2** Oil fuel – means any oil used as fuel in connection with the propulsion and auxiliary machinery of the ship in which such oil is carried.
- .3** Oily mixture – means a mixture with any oil content.
- .4** Oil sludge – means residues resulting from the oil separation, and bilge oily water treatment (sludge), as well as oil leaks, drains of settled oil, drains from oil tanks, and all used oils..
- .5** Oily bilge water – means the oil contaminated water from the ship machinery space bilges, with the exception of water from cargo pump room bilges of an oil tanker.
- .6** Oil tanker – means a support ship constructed or adapted for carriage in its cargo spaces (tanks) oil cargo in bulk.
- .7** Clean ballast – means, in relation to oil tankers, the ballast in a tank which, since oil was last carried therein, has been so cleaned that the oil content on discharge, if the ballast is discharged through an approved oil discharge monitoring and control system, does not exceed 15 ppm. Water discharged from such tank, when ship is stationary, on a clean calm water on a clear day would not produce visible traces of oil on the surface of the water or on adjoining shorelines or cause a sludge or emulsion to be deposited beneath the surface of the water or upon adjoining shorelines.

2.1.2 Application

2.1.2.1 Sub-chapter 2.1 contains requirements concerning prevention of pollution by oil from naval ships.

2.1.2.2 The requirements of the sub-chapter 2.1 apply to all ships, both combat and support ships.

2.1.2.3 Compliance with the requirements of the present sub-chapter is necessary for affixing the ship with the mark MAR I .

2.1.2.4 Polish Register of Shipping shall be informed by the competent services of the Purchaser on all matters which may affect the fulfilment of the requirements of sub-chapter 2.1, and thus maintenance of the MAR I character and validity of the issued *Certificate*.

2.1.3 Issue of documents

The ship complying with the requirements of sub-chapter 2.1 is provided with the *Certificate of Compliance with the Requirements for Marine Environment Protection from Pollution by Oil*.

2.1.4 Technical requirements

2.1.4.1.1 Every ship shall comply with the applicable requirements of paragraphs 2.1.4.2 do 2.1.4.18 and requirements of chapters 6 and 7 of the *Part VI – Machinery Installations and Refrigerating Plants*. Oil tankers shall, in addition, comply with the requirements of paragraphs 2.1.4.19 to 2.1.4.21.

2.1.4.2 From ships to which the requirements of sub-chapter 2.1 apply, any discharge into the sea of oil, oily mixtures and oily bilge water is prohibited, unless:

- .1 the discharge takes place in exceptional circumstances described in the Regulation 11 of Annex I to the Convention MARPOL 73/78, or
- .2 discharged is oily bilge water containing oil residues in proven amount not exceeding 15 parts per million parts of water (15 ppm).

2.1.4.3 Every ship of displacement 500 t or greater shall be equipped with

- .1 the hull structural or inserted bilge water tank designated for collection of oily water from machinery spaces bilges;
- .2 one or more hull structural or inserted oil sludge tanks, in which sludge from fuel oil and lubricating oil separators, as well as from oily water separator, shall be collected;
- .3 the hull structural or inserted slop oil tanks, in which all slops of fuel oil and lubricating oil, as well as used oil, shall be collected.

The capacity of these tanks shall be sufficient for the duration of the longest trip between the ports where their contents can be transferred to the land or floating reception facilities. In addition, the capacity of the waste oil tank specified in .3 shall be sufficient to accommodate the oil used by the largest main propulsion engine or a generator drive, except that for this purpose, a separate waste oil tank is applied. Determination the volume of the tanks mentioned in .2 and .3 shall be guided by the circular issued by IMO MEPC/Circ.265 containing guidance on the handling of waste oil in machinery spaces.

2.1.4.4 In ships using for combustion only light grades of fuel, tanks referred to in 2.1.4.3.2 and 2.1.4.3.3 may be common, and their total capacity should be equal to, or greater than, the aggregated capacity of capacities required for each tank separately.

2.1.4.5 Oily bilge water retained in tanks referred to in 2.1.4.3.1, if not discharged as described in 2.1.4.2.2, shall be discharged to shore or floating reception facilities..

2.1.4.6 Sludge, slops and used lubricating oil retained in tanks referred to in 2.1.4.3.2 and 2.1.4.3.3 shall be discharged to floating or shore reception facilities, or burned in incinerators.

2.1.4.7 Tanks for retention of oily bilge water, oil sludge and slops, referred to in 2.1.4.3.1, 2.1.4.3.2 and 2.1.4.3.3, shall be so constructed, that periodical removal of sediments gathered on their bottoms was possible.

2.1.4.8 Every ship having the tank, referred to in 2.1.4.3.1, for the retention of bilge water shall be provided with the installation for discharge the bilge water from the machinery space bilges into that tank. The installation shall be provided with a bilge pump and piping enabling the effective drainage of all the machinery spaces. The installation shall not have any connections neither with the bilge drainage installation required for safety reasons (see sub-chapters 6.1 and 6.2 of *Part VI*), nor the ballast installation.

2.1.4.9 Every ship having the tank, referred to in 2.1.4.3.1, for the retention of bilge water shall be provided with the installation for the discharge of the bilge water from the tank to the shore or floating reception facilities. Installation for the discharge of the oily bilge water shall be provided with the pump enabling effective discharge, and the discharge connection provided with a standard flange conforming with Regulation 19 of Annex I to *MARPOL 73/78 Convention*.

2.1.4.10 In lieu of pumps referred to in 2.1.4.8 i 2.1.4.9 one bilge pump designated for both, drainage of the machinery spaces bilges and discharge of the oily bilge water, may be provided.

2.1.4.11 Every ship having the tanks, referred to in 2.1.4.3.2 and 2.1.4.3.3, shall be provided with the installation for the discharge of sludge and slops to shore or floating reception facilities. The installation shall be provided with the pump enabling effective discharge, and the discharge connection provided with a standard flange conforming with Regulation 19 of Annex I to *MARPOL 73/78 Convention*.

2.1.4.12 The installations referred to in 2.1.4.9 and 2.1.4.11 shall not have any connections with the overboard valves.

2.1.4.13 In lieu of the discharge connections referred to in 2.1.4.9 and 2.1.4.11 one discharge connection may be installed provided that effective solution (e.g. return valve, three-way valve) preventing passage of sludge to oily bilge water installation has been applied.

2.1.4.14 In ships provided with oily bilge water tanks referred to in 2.1.4.3.1 as well as sludge and slope tanks referred to in 2.1.4.4, in lieu of pumps referred to in 2.1.4.10 and 2.1.4.11 one pump for the discharge of oily bilge water, oil sludge and slops may be provided.

2.1.4.15 Ships of a displacement 100 t or greater, but less than 500 t, shall be provided with at least one tank for collection of oily bilge water, oil sludge and slopes, as well as installation for drainage of machinery spaces bilges and the discharge the tank contents to the shore or floating reception facilities. The installation shall be provided with the pump enabling effective drainage of bilges and emptying the tank, as well as the discharge connection provided with a standard flange conforming with Regulation 19 of Annex I to *MARPOL 73/78 Convention*.

2.1.4.16 Ships with a displacement below 100 t, for which, due to design reasons, tanks for the collection of bilge water can not be applied, may collect oily bilge water in machinery spaces' bilges. In such cases in lieu of oily bilge water discharge installation, installation for discharge by the external recipient may be provided. Such installation shall enable effective drainage of machinery spaces' bilges by means of the recipient pump. To the installation may also be connected installation for emptying and discharge of sludge tanks. In this case instead of standard discharge connection other discharge connection, agreed with the recipient, may be provided.

2.1.4.17 In ships, where technically possible, and due to operating conditions reasonable, in addition to the oily bilge water discharge installation required in 2.1.4.9, the oily bilge water filtering equipment meeting the requirements set out in regulation 16 (5) in Annex I of *MARPOL 73/78*. For the collection of bilge water both: tank referred to in 2.1.4.3.1 and bilge machinery spaces can then be used. If, before transferring to a filtering device, the oily bilge water will be collected in a tank it is recommended that the reservoir is as high as possible, so as to allow gravitational separation of oil; for removing oil from the water surface draining funnels placed at appropriate levels should be applied. Piping draining oil from the funnels shall be fitted with stop valves or cocks.

2.1.4.18 Tanks for fuel oil of density $0,9 \text{ g/cm}^3$ and greater and lubricating oil tanks, with exception of the main engine circulating oil tanks, shall be separated from sides and outer bottom by means of cofferdams of width at least 0,76 m. Suction wells in the tanks may protrude below the bottom of the tanks, provided that they have the smallest possible size, and the distance from the bottom of the well to the outer shell will be at least half the width of the cofferdam.

2.1.4.19 In oil tankers the oily bilge water from the cargo-pump room bilges and from the oil residues tanks shall be discharged to the shore or floating reception facilities.

2.1.4.20 Ballast water from the cargo tanks used as ballast tanks shall be discharged to the shore or floating reception facilities. Discharge of such ballast water into the sea is allowed only outside the special areas, and is permitted only in compliance with the provisions of regulation 9 and with application of oil discharge monitoring and control system complying with the regulation 15(3) of Annex I to *MARPOL 73/78 Convention*.

2.1.4.21 Discharge of ballast water from the cargo tanks complying with the requirements for designated clean ballast tanks shall be performed in compliance with the regulation 13A(3) through an oil content meter approved in conformity with the provisions of IMO Resolution MEPC.60(33), and the oil content in the discharged water shall not exceed 15 ppm.

2.1.5 Required operational documentation

2.1.5.1 Every ship provided with the oily bilge water filtering equipment referred to in 2.1.4.17 shall carry on board *Operational manual* of the device. The *Manual* shall also give the information whether the equipment can be used in special areas, as well as definition or a map with indication of special areas in accordance with *MARPOL 73/78 Convention*, Annex I, Regulation 10.

2.1.5.2 Every ship of displacement 200 t or greater shall carry on board approved by PRS and updated (i.e. fully complying with actual situation on the ship) bilge and oil sludge scheme. For the new ships such scheme shall be presented for approval at the stage of design.

2.1.5.3 Every ship shall carry on board developed and implemented procedures for operation of lubricating oil, fuel oil, oily bilge water and oil residues (sludge) systems. The procedures shall comprise at least:

- .1 bunkering, storing and transferring of fuel oil, lubricating oil, hydraulic and heating oil, as well as oil delivered in barrels;
- .2 collecting, storing, transferring and discharge of oil residues, as well as oily water;
- .3 proceeding with the recovered oil in the case of spill.

2.1.5.4 Every ship shall carry on board developed and implemented procedures for combating oil pollution incidents. The procedures shall be developed on the basis of provisions for a shipboard oil emergency plans contained in IMO guidelines: resolution MEPC. 54(32), an amendments adopted by resolution MEPC.86(44).

2.1.5.5 On every ship, operations concerning transfer of fuel oil, lubricating oil, hydraulic, heating oils and oil residues, as well as oily water and ballast water shall be recorded. The records shall be entered to the *Oil Record Book*, which form is presented in Appendix III of Annex I to *MARPOL 73/78 Convention*

2.2 Annex III – Prevention of pollution by harmful substances carried in packaged form

2.2.1 Definitions

- .1 **Harmful substance** – means the substance identified in *IMDG Code* as a marine pollutant. Empty packaging which have been used previously for the carriage of harmful substances shall themselves be treated as harmful substances unless harmful residues have been removed from them.

- .2 IMDG Code – means *International Maritime Dangerous Goods Code* adopted by IMO by resolution A. 716(17), as amended.
- .3 Package – means an article ensuring maintenance of a specified quality of the packaged products, adapting them to the transport and storage and presentation, as well as protecting the environment from the harmful effects of certain products.

2.2.2 Application

2.2.2.1 Sub-chapter 2.2 contains requirements concerning prevention of pollution by harmful substances carried by naval ships in packaged form.

2.2.2.2 The requirements of sub-chapter 2.2 concern supply and logistic support ships, which may carry various cargoes, including harmful cargoes in packages, as well as all other ships on board of which may be carried packaged harmful substances.

2.2.3 Technical requirements

2.2.3.1 General

- .1 The carriage of harmful substances is permitted provided its execution in accordance with the provisions of the sub-chapter 2.2.
- .2 Removal overboard of harmful substances carried in packages is prohibited, except in cases where it is necessary for the ship safety, or for the rescue of the life at sea.
- .3 Washing overboard residues or leakages of harmful substances is allowed while maintaining the safety of the ship and persons, in accordance to the rules resulting from physical, chemical and biological properties of these substances.
- .4 Harmful substances carried in packages shall be so stowed and secured as to minimize the hazards to the marine environment without impairing the safety of the ship and persons on board.

2.2.3.2 Packing

- .1 Packages applied for carriage of harmful substances shall be adequate to the specific substance, having regard the hazard created by the substance to the marine environment.
- .2 Packages shall fully comply with the requirements contained in *IMDG Code*.

2.2.3.3 Marking

- .1 Packages containing harmful substances shall be durably marked with the correct technical name, indication of hazard character created by the substance, as well as shall be durably marked or labelled with the text „MARINE POLLUTANT” indicating that the package contains harmful substance.
- .2 Marking shall conform with the requirements of *IMDG Code*.

2.2.3.4 Required operational documentation

- .1 The shipping documents supplied by the shipper shall include, or be accompanied by, a signed certificate or declaration that the shipment offered for carriage is properly packaged and marked, labelled or placarded as appropriate and in proper condition for carriage to minimize the hazard to the marine environment.
- .2 Each ship carrying harmful substances shall have a detailed stowage plan setting out the location of the harmful substances on board or list setting forth the harmful substances on board and their location thereof. Set of copies of such documents shall be retained by the Purchaser.
- .3 Every ship shall carry on board developed and implemented procedures for reporting in the case of incidents with the harmful substances. The procedures shall be developed on the basis of the provisions of IMO resolution A.851(20) setting forth the general principles for ship reporting systems and ship reporting requirements, including guidelines for reporting incidents involving dangerous goods, harmful substances and/or marine pollutants

2.3 Annex IV – Prevention of pollution by sewage

2.3.1 Definitions

- .1 Sewage – means:
 - (a) drainage and other wastes from any form of toilets and urinals;
 - (b) drainage from medical premises (dispensary, sick bay, etc.) via wash basins, wash tubes and scuppers located in such premises;
 - (c) drainage from spaces containing living animals; or
 - (d) other waste waters when mixed with the drainages defined above.
- .2 Holding tank – means a tank used for the collection and storage of sewage.
- .3 Nearest land – the term "from the nearest land" means from the base line from which the territorial sea of the territory in question is established in accordance with international law.

2.3.2 Application

2.3.2.1 Sub-chapter 2.3 contains requirements concerning prevention of pollution by sewage from naval ships.

2.3.2.2 The requirements of the sub-chapter 2.3 apply to all ships, both combat and support ships.

2.3.2.3 Compliance with the requirements of the present sub-chapter is necessary for affixing the ship with the mark MAR IV.

2.3.2.4 Polish Register of Shipping shall be informed by the competent services of the Purchaser on all matters which may affect the fulfilment of the requirements of sub-chapter 2.3, and thus maintenance of the MAR IV character and validity of the issued *Certificate*.

2.3.3 Issue of documents

2.3.3.1 The ship complying with the requirements of sub-chapter 2.3 is provided with the *Certificate of Compliance with the Requirements for Marine Environment Protection from Pollution by Sewage*.

2.3.4 Technical requirements

2.3.4.1 Every ship shall comply with the applicable requirements of paragraphs 2.3.4.2 do 2.3.4.11 and requirements of chapter 20 of the *Part VI – Machinery Installations and Refrigerating Plants*.

2.3.4.2 The discharge of sewage from the ship into the sea at a distance less than 12 Nm is prohibited, except when:

- .1 the ship is discharging in exceptional situations described in Regulation 3 of Annex IV to *MARPOL 73/78 Convention*;
- .2 the ship is discharging at the distance of more than 4 Nm, and prior the discharged sewage is comminuted and disinfected with the use of the approved system;
- .3 the ship is discharging in the waters under the jurisdiction of a State, which imposed less stringent requirements; or
- .4 the ship is discharging sewage after being treated by the approved sewage treatment plant..

2.3.4.3 At a distance of more than 12 Nm from the nearest land the discharge of not treated, stored in holding tanks sewage shall not be instantaneously but at a moderate rate when the ship is *en route* and proceeding at not less than 4 knots.

2.3.4.4 Every ship shall be provided with one of the following sewage systems:

- .1 a sewage treatment plant which shall comply with the technical standards and test methods developed by IMO1), or
- .2 a sewage comminuting and disinfecting system approved by PRS (*Administration????!!*); such system shall be fitted with, complying with the requirements of the present sub-chapter, tanks for temporary storage of sewage when the ship is less than 3 Nm from the nearest land; or
- .3 a holding tank, for the retention of all sewage, of the capacity complying with the requirements of the present sub-chapter, having regard to the operation of the ship, the number of persons on board and other relevant factors; the tank shall be provided with a high level alarm and installation for the tank washing.

2.3.4.5 The capacity of the tanks referred to in 2.3.4.4.3 shall be determined on the assumption that with conventional flushing system for one person per day 50 l provided, and 15 l using a vacuum system, where into the tank only sewage are

¹⁾ Refer to the Recommendation on international effluent standards and guidelines for performance tests for sewage treatment plants adopted by IMO by resolution MEPC.2(VI) on 3 December 1976 r.

directed and, respectively, 200 and 150 l when into the tank other sanitary drainage water is also directed. The applicability of the tanks of smaller capacity is permitted only in technically justified cases and in each case is subject to special consideration by PRS.

2.3.4.6 Every ship shall be provided with the system for the discharge of sewage to shore or floating reception facilities. The system shall be provided with the pump enabling effective emptying of the retention tank and/or the tanks forming sewage treatment plant's chambers. For ships on which due to limited dimensions provision of the pump is impossible or unreasonable, for the sewage discharge recipient pump may be used.

2.3.4.7 Every ship, for the discharge of sewage from the tank and/or sewage treatment plant, shall be provided with the discharge connection with the standard flange complying with the provisions of Annex IV to *MARPOL 73/78 Convention*. In the case of discharging by the recipient pump, instead of standard discharge connection other discharge connection, agreed with the recipient, may be provided.

2.3.4.8 For ships which from definition will not sail at a distance of more than 12 Nm from the nearest land, the installation for the discharge the sewage into the sea shall not be fitted..

2.3.4.9 For ships of length L less than 24 m, in lieu of retention tank referred to in 2.3.4.4.3 portable retention tanks of capacity not exceeding 20 l each, made in accordance with ISO 8099 standard, may be provided, which shall be emptied to the shore or floating reception facilities, or into the sea at the distance more than 12 Nm from the nearest land. As an alternative solution, portable chemical toilets of sufficient number and capacity appropriate to the number of persons on board; contents of these toilets shall be emptied to the shore or floating sanitary reception facilities, or into the sea at the distance of more than 3 Nm from the nearest land.

2.3.4.10 Every ship on which installation for the sewage discharge from the retention tank, and/or tanks forming a sewage treatment plant's chambers, into the sea, as well as installation for direct sewage discharge into the sea is provided, in the vicinity of the outlet valve shall be placed a table with the text:

Non-processed sewage.

The discharge overboard at the distance less than 12 Nm from the closest land is prohibited.

2.3.5 Required operational documentation

2.3.5.1 Every ship of displacement 200 t or greater shall carry on board approved by PRS and updated (i.e. fully complying with actual situation on the ship) sewage system scheme. For the new ships such scheme shall be presented for approval at the stage of design.

2.3.5.2 Every ship provided with the equipment referred to in 2.3.4.4.1 or 2.3.4.4.2 shall carry prominently posted a durable and legible *Operating Manual* of these devices.

2.3.5.3 Every ship shall carry developed and implemented procedures for handling the sewage system. Records of the equipment inspections, carried out maintenance and repair works, as well as results of performance and disinfectants dosage measurements. Where the sewage treatment plant is fitted, periodical (at least every 5 years of uninterrupted work and after each repair requiring laying -up of the plant) laboratory tests of samples of water taken at the outlet from the plant shall be carried out.

2.4 Annex V – Prevention of pollution by garbage

2.4.1 Definitions

- .1** Garbage – means all kinds of victual, domestic and operational waste generated during the normal operation of the ship and liable to be disposed continuously or periodically except those substances which are defined or listed in other Annexes to the *MARPOL 73/78 Convention*.
- .2** Nearest land – the term "from the nearest land" means from the base line from which the territorial sea of the territory in question is established in accordance with international law.
- .3** Special area – means a sea area where for recognized technical reasons in relation to its oceanographical and ecological condition and to the particular character of its traffic the adoption of special mandatory methods for the prevention of sea pollution by garbage is required. Special areas shall include those listed in regulation 5 of the Annex V to the *MARPOL 73/78 Convention*.

2.4.2 Application

2.4.2.1 Sub-chapter 2.4 contains requirements concerning prevention of pollution by sewage from naval ships.

2.4.2.2 The requirements of the sub-chapter 2.4 apply to all ships, both combat and support ships.

2.4.2.3 Compliance with the requirements of the present sub-chapter is necessary for affixing the ship with the mark MAR V.

2.4.2.4 Polish Register of Shipping shall be informed by the competent services of the Purchaser on all matters which may affect the fulfilment of the requirements of sub-chapter 2.4, and thus maintenance of the MAR V character and validity of the issued *Certificate*.

2.4.3 Issue of documents

2.4.3.1 The ship complying with the requirements of sub-chapter 2.4 is provided with the *Certificate of Compliance with the Requirements for Marine Environment Protection from Pollution by Garbage*.

2.4.4 Technical requirements

2.4.4.1 Every ship shall comply with applicable requirements of paragraphs 2.4.4.2 to 2.4.4.9.

2.4.4.2 Disposal of any garbage into the sea is prohibited, unless:

- .1 the disposal takes place in exceptional circumstances described in the Regulation 6 of Annex V to *MARPOL 73/78 Convention*,
- .2 the disposal takes place outside special areas and is made in accordance with the conditions specified in the regulation 3 of Annex V to *MARPOL 73/78 Convention*,
- .3 the disposal takes place within special areas and is made in accordance with the conditions specified in the regulation 5 of Annex V to *MARPOL 73/78 Convention*.

2.4.4.3 Every ship shall be provided with means enabling storage of garbage generated on board until their discharge to the shore or floating reception facilities or their disposal into the sea in accordance with the conditions specified in 2.4.4.2.2 and 2.4.4.2.3.

2.4.4.4 For the garbage storage metal containers with tight seals shall be used. The number and size of containers shall be determined taking into account the type of ship, crew number, estimated time spent at sea and the preparation of reception facilities, for which the ship calls in order to discharge segregated garbage. If for the storage of garbage separate, enclosed spaces are provided, the garbage in these spaces shall be stored in a strong, appropriately labelled bags.

2.4.4.5 Containers located on open decks shall be of solid construction and provided with a tight closure, be reliably fastened to the structure of the ship and have a clear indication of what types of garbage they are intended for.

2.4.4.6 Ships of unrestricted service shall be provided with the containers designated for at least three kind of garbage, having regard to the possibility of their disposal into the sea in accordance with the conditions specified in the regulation 3 of Annex V to *MARPOL 73/78 Convention*, whereas the ships operating exclusively in special areas specified in the regulation 5 of Annex V to *MARPOL 73/78*

Convention, in containers for at least two kind of garbage. Number of containers designated for segregated garbage may be increased, if their discharge to the shore or floating reception facilities, in a manner agreed with those facilities, is provided. It is recommended that for ships operating in special areas the minimum aggregated volume of containers for garbage storage is determined on assumption of 2 – 3 l for the person per day.

2.4.4.7 The incinerator, if provided on the ship, shall be of type approved and complying with the requirements of IMO resolution MEPC.76(40) and amendments adopted by resolution MEPC.93(45).

2.4.4.8 If the ship is provided with garbage processing equipment such as squeezers or comminuters, their design is subject of agreement with PRS.

2.4.4.9 On each ship shall be fitted permanent placards, measuring at least 12.5 to 20 cm, informing the crew on the terms of disposal of garbage into the sea. It is recommended that placards were mounted in kitchens, messes and other public areas, in the engine room, at the entrances to the superstructures and the places where garbage is stored. The text of placards shall contain information in accordance with the requirements of Annex V to *MARPOL 73/78 Convention*, as appropriate to the area of navigation of the ship. The following table contains the necessary information in accordance with the requirements of regulations 3, 4 and 5 of Annex V to *MARPOL 73/78 Convention*, which shall be included on the placards.

Table 2.4.4.9

Kind of garbage	All ships	
	Outside special areas	◆◆Within special areas
1	2	3
All plastics, including synthetic ropes, synthetic fishing nets, plastic garbage bags and incinerator ashes from plastic products which may contain toxic or heavy metal residues.	disposal prohibited	disposal prohibited
Dunnage, lining and packing materials which will afloat.	> 25 Nm from the nearest land	disposal prohibited
Paper products, rags, glass, metal, bottles crockery and similar refuse.	> 12 Nm from the nearest land	disposal prohibited
◆ Paper products, rags, glass, metal, bottles crockery, etc. comminuted or ground.	> 3 Nm from the nearest land	disposal prohibited
Food wastes not comminuted or ground.	> 12 Nm from the nearest land	> 12 Nm from the nearest land
◆ Food wastes comminuted or ground.	> 3 Nm from the nearest land	> 12 Nm from the nearest land
Garbage mixed with other discharges having different disposal requirements.	◆◆◆	◆◆◆

- ◆ Garbage comminuted or ground, capable of passing through a screen with openings not greater than 25 mm.
- ◆◆ The special areas are: the Mediterranean Sea, the Baltic Sea, the Black Sea, the Red Sea, the "Gulfs area", the North Sea, the Arctic Sea, the Gulf of Mexico and the Caribbean Sea.
- ◆◆◆ When the garbage is mixed with other discharges having different disposal or discharge requirements the more stringent requirements shall apply.

2.4.5 Required operational documentation

2.4.5.1 Every ship of displacement of 200 t or greater shall carry a garbage management plan. The plan shall be elaborated in accordance with the guidelines described in adopted by IMO resolution MEPC.71(38), and approved by PRS.

2.4.5.2 Every ship of displacement of 200 t or greater shall carry the Garbage Record Book, elaborated in the form specified by IMO. The records in the book shall be made and kept in accordance with the regulation 9 of Annex V to *MARPOL 73/78 Convention*.

2.5 Annex VI – Prevention of air pollution

2.5.1 Definitions

- .1 Sulphur Oxide (SO_x) Emission Control Areas – means the areas indicated in the resolution 14(3) of Annex VI to *MARPOL 73/78 Convention*, within which the ship shall comply at least with one of the given in resolution 14(4) condition of SO_x emission control.
- .2 Major Conversion of the Engine – means i.e. modification of the engine as described in the 1.3.2 of the *NO_x Technical Code*.
- .3 NO_x Technical Code – means the *Technical Code on Control of Emission of Nitrogen Oxides from Marine Diesel Engines* adopted in 1997 by the International Conference of the Parties to *MARPOL 73/78 Convention* Resolution 2, and constituting the Annex to the Resolution.

2.5.2 Application

2.5.2.1 Sub-chapter 2.5 contains requirements concerning prevention of air pollution by naval ships.

2.5.2.2 The requirements of the sub-chapter 2.5 apply, if not provided otherwise, to all ships.

2.5.2.3 Compliance with the requirements of the present sub-chapter is necessary for affixing the ship with the mark MAR VI.

2.5.2.4 Polish Register of Shipping shall be informed by the competent services of the Purchaser on all matters which may affect the fulfilment of the requirements of sub-chapter 2.5, and thus maintenance of the MAR VI character and validity of the issued *Certificate*.

2.5.3 Issue of documents

2.5.3.1 The ship complying with the requirements of the present sub-chapter is provided with the *Certificate of Compliance with the Requirements for the Prevention of Air Pollution from Ships*.

2.5.4 Application to the naval ships of the requirements of Annex VI to MARPOL 73/78 Convention

2.5.4.1 General

2.5.4.2 From ships to which apply the requirements of the present sub-chapter, emissions of air pollutants beyond acceptable standards is prohibited, unless it is necessary for reasons of safety of the ship or safety of life at sea, or is the result of damage to the ship or its equipment.

2.5.4.3 Requirements concerning (SO_x) emission control

2.5.4.3.1 The present requirements shall comply to all naval ships.

2.5.4.3.2 Every naval ship operating in the Baltic Sea or in the North Sea, which have been established the sulphur oxide emission control areas (and in other such areas which will be established in the future) shall feed all types of diesel engines, both: the main and auxiliary, with the fuel oil of sulphur content not exceeding 1,5% m/m.

2.5.4.3.3 Every naval ship staying in the ports located in the Baltic Sea and in the North Sea shall use the fuel oil of the sulphur content not exceeding 0,5% m/m.

2.5.4.3.4 Every naval ship operating outside the Baltic Sea shall use fuel oil of sulphur content not exceeding 4,5% m/m, unless the local regulations require use of fuel oil with the lower sulphur content.

2.5.4.3.5 Where a ship using a fuel oil of specified sulphur content enters the area where it is required to use fuel oil with lower sulphur content, it should have the fuel system completely flushed from the fuel of higher sulphur content..

2.5.4.3.6 In the case when, in the areas indicated in 2.5.4.3.2 and 2.5.4.3.4, delivery of fuel oil with the required sulphur content is not possible, then the fuel oil of lower sulphur content shall be delivered.

2.5.4.3.7 On each ship records, enabling estimation of an amount of each fuel oil kind in each tank, as well as the date, an hour and the ship's position at the time of completion the operation of transition to another kind of fuel oil, shall be kept.

2.5.4.3.8 On each ship shall be developed and applied the procedures governing the methods for the sampling of fuel delivered to the ship in case there was a need to check its sulphur content, in this case, methods consistent with the recommendations of the IMO Resolution MEPC.96 (47) containing guidelines for the sampling of fuel oil to comply with the requirements of Annex VI to the *MARPOL 73/78 Convention* may be applied.

2.5.4.4 Requirements concerning (NO_x) emission control

2.5.4.4.1 The present requirements apply to all diesel engines with a power output of more than kW, irrespective of their designation, except of the engines designated exclusively for operation in emergency situations:

- .1 installed on naval ships constructed on or after 1 January 2000,
- .2 which were constructed or undergone major conversion on or after 1 January 2000.

2.5.4.4.2 All engines to which the present requirements apply shall, in a scope of NO_x emission control, conform with the requirements of the Regulation 13(3)(a) of Annex VI to *MARPOL 73/78 Convention* and shall be provided with *Engine International Air Pollution Prevention (EIAPP Certificate)*. Those engines during their service shall be subject to applicable surveys listed in paragraph 2.1.1 of the *NO_x Technical Code*.

2.5.4.4.3 When the emission values of nitrogen oxides referred to in regulation 13 of Annex VI of *MARPOL 73/78 Convention* for a particular engine are exceeded, agreed with PRS and approved exhaust gas cleaning system, capable of reducing emissions at least to the values given in that above regulation shall be applied.

2.5.4.4.4 Possibility to take measurements of engine emissions of nitrogen oxides during the survey of the ship in accordance with Chapter 6 of the *NO_x Technical Code* shall be assured.

2.5.4.4.5 Equipment used to measure the emissions of nitrogen oxides shall meet the following requirements:

- .1 damage to any element of the equipment shall not disturb continuous, safe operation of the engine;
- .2 shall be so designed, constructed and fitted that the access for service, surveys and repairs was possible;
- .3 shall be provided with the recorder of measured parameters.

2.5.4.4.6 For the equipment referred to in 2.5.4.4.5, the procedures for service, adjustment, surveys and repairs shall be elaborated.

2.5.4.4.7 Records showing the operation of measuring devices, and obtained in this way the values of nitrogen oxide emissions, shall be kept and made available to surveyors during PRS survey of the ship referred to in regulation 5 of Annex VI to *MARPOL 73/78 Convention*.

2.5.4.5 Requirements concerning of ozone-depleting substances emission limitation

2.5.4.5.1 The present requirements apply to the installation of fire protection, refrigeration, air-conditioning and water cooling on all naval ships. They do not apply to refrigerators and freezers used in kitchens, pantries, messes and crew accommodation.

2.5.4.5.2 Application of halon in fixed fire-fighting installations and extinguishers is forbidden.

2.5.4.5.3 Application in refrigeration, air-conditioning and water cooling systems of coolants containing chlorofluorocarbons (CFC) is forbidden. Application of refrigerants containing hydrochlorofluorocarbons (HCFC) is permitted until 31 December 2009.

2.5.4.5.4 To carry out inspections and repairs without having to release refrigerant from the installation into the atmosphere, refrigeration, air conditioning and water cooling systems piping installations shall be designed to allow the isolation and the transfer of the refrigerant fluid from the individual sections of pipelines to the coolant tank. Small leaks of coolant, inevitable in this kind of work, are allowed.

2.5.4.5.5 For the purpose of the refrigerant recovery, the systems shall be so designed that with use of the compressor all refrigerant from the installation can be transferred to the refrigerant tank.

2.5.4.5.6 Leaks of the refrigerant shall be brought to the minimum through the application of procedures for prevention and periodical detection of leaks. Leaks from any system shall not exceed, within one year, 10% of the total refrigerant amount.

2.5.4.5.7 Application of, specific to each type of refrigerant, system of continuous monitoring of leakage in those spaces where such leaks may occur, as well as an alarm led into places with continuous surveillance, signalling exceeded the permissible levels defined for a given refrigerant.

2.5.4.5.8 The appropriate procedures specifying the principles for the control of loss, leakage and delivery to reception facilities of the refrigerant shall be developed and applied.

2.5.4.5.9 On the ship shall be kept records relating to:

- quantities of the refrigerant added to each system,
- refrigerant leakages and actions undertaken,
- quantities of recovered refrigerant and places of its storage,
- refrigerant consumption, and
- refrigerant delivery to the shore or floating reception facilities.

2.5.4.6 Requirements concerning shipboard incinerators

2.5.4.6.1 Each incinerator installed on the ship on or after 1 January 2000 shall comply with the standard technical requirements included in the adopted by IMO resolution MEPC.76(40).

2.5.4.6.2 Procedures for incinerator operation ensuring operational conditions specified in the Appendix IV to Annex VI to *MARPOL 73/78 Convention* shall be developed.

3 TRANSIENT REQUIREMENTS RELATING TO SOLAS CONVENTION, CHAPTER III – LIFE-SAVING APPLIANCE AND ARRANGEMENTS

3.1 Application

3.1.1.1 This chapter 3 apply to surface naval ships and support vessels

3.1.2 Requirements of chapter 3 have been elaborated on the basis of *Naval Ship Code, Chapter VII – Escape, Evacuation and Rescue* (draft) and are of transient nature. Depending on the final form of *Naval Ship Code*, a range of the requirements given in chapter 3 may be amended. All life-saving appliances indicated in chapter 3 shall conform with the requirements of the *International Life-Saving Appliance (LSA) Code (LSA Code)*.

3.1.3 As for the existing ships – compliance of life-saving appliances with the requirements of the chapter 3, as far as practicable, should be ensured.

3.1.4 The requirements of the chapter 3 conform to the requirements of *SOLAS 74 Convention* and adopted amendments in force, concerning life-saving appliances.

3.2 Definitions

Adequately trained personnel – personnel familiarized with the release gear of type "release gear under load".

Anti-exposure suit – a protective suit designed for use by rescue boat crews and marine evacuation system parties.

Detection – the determination of the location of survivors or survival craft.

Embarkation ladder – the ladder provided for survival craft embarkation station to permit safe access to survival craft after launching.

Fast rescue boat – a rescue boat of minimum 6 m length with self-righting arrangement, capable to develop on a calm water a speed not less 20 knots with three persons of the crew.

Float-free launching – a method of launching a survival craft whereby the craft is automatically released from a sinking ship and is ready for use.

Free-fall acceleration – the rate of change of velocity experienced by the occupants during launching of a free-fall lifeboat.

Free-fall launching – a method of launching a survival craft whereby the craft with its complement of persons and equipment on board is released and allowed to fall into the sea without any restraining apparatus.

Immersion suit – a protective suit which reduces the body heat loss of a person wearing it in cold water.

Inflatable appliance – an appliance which depends upon non-rigid, gas-filled chambers for buoyancy and which is normally kept uninflated until ready for use.

Inflated appliance – an appliance which depends upon non-rigid, gas-filled chambers for buoyancy and which is kept inflated and ready for use at all times.

International Life-Saving Appliance (LSA) Code – the International Life-Saving Appliance (LSA) Code adopted by the Maritime Safety Committee of the Organization by resolution MSC.48(66)..

Launching appliance or arrangement – a means of transferring a survival craft or rescue boat from its stowed position safely to the water.

Launching ramp angle – the angle between the horizontal and the launch rail of the lifeboat in its launching position with the ship on even keel.

Launching ramp length – the distance between the stern of the lifeboat and the lower end of the launching ramp

Length – 96% of the total length on a waterline at 85% of the least moulded depth measured from the top of the keel, or the length from the fore-side of the stem to the axis of the rudder stock on that waterline, if that be greater. In ships designed with a rake of keel the waterline on which this is measured shall be parallel to the designed waterline.

Means of rescue – the means for the safe recovery of survivors from the water to the level of the ship's open deck.

Moulded depth – the vertical distance measured from the top of the keel to the top of the freeboard deck at side. In ships having rounded gunwales, the moulded depth shall be measured to the point of intersection of the moulded lines of the deck and side shell plating, the lines extending as though the gunwale were of angular design. Where the freeboard deck is stepped and the raised part of the deck extends over the point at which the moulded depth is to be determined, the moulded depth shall be measured to a line of reference extending from the lower part of the deck along a line parallel with the raised part.

Opening in a ship's side – all openings in a ship's side, such as

- permanent openings, recesses;
- closing openings: such as side doors, windows, sidescuttles or side ports.

Recovery time for a rescue boat – the time required to raise the boat to a position where persons on board can disembark to the deck of the ship. Recovery time includes the time required to make preparations for recovery on board the rescue boat such as passing and securing a painter, connecting the rescue boat to the launching appliance, and the time to raise the rescue boat. Recovery time does not include the time needed to lower the launching appliance into position to recover the rescue boat.

Rescue boat – a boat designed to rescue persons in distress and to marshal survival craft.

Retrieval – the safe recovery of survivors.

Retro-reflective material – a material which reflects in the opposite direction a beam of light directed on it.

SOLAS – International Convention for the Safety of Life at Sea 1974, as amended.

Survival craft – a craft capable of sustaining the lives of persons in distress from the time of abandoning the ship.

Thermal protective aid – a bag or suit made of waterproof material with low thermal conductance.

Water-entry angle – the angle between the horizontal and the launch rail of the lifeboat when it first enters the water.

3.3 Technical documentation of life-saving appliances for the new ship

3.3.1 Prior to the commencement of construction of a ship which equipment is covered by the *Rules* requirements, following technical documentation shall be submitted to PRS Head Office for consideration and approval:

- .1 Life-saving appliances arrangement describing:
 - type of the ship, displacement, the ship's length, number of persons;
 - arrangement of lifeboats, rescue boats, liferafts, lifebuoys and lifejackets, embarkation ladders, pyrotechnics and launching arrangements;
 - type, number and manufacturers of the specified life-saving means and appliances;
 - SWL (safe working load) of fastening elements, breaking load and material;
 - distance between the edge of the boat stern and the front edge of the ship's propeller;
 - the life-saving means and appliances stowage height above the waterline of the ship's smallest draught;
 - means of operation of launching arrangements for survival crafts and rescue boats;
 - location of life-saving equipment operating instructions, passageways to the survival crafts, muster stations with identification of their areas [m²];
 - location of guard-rails in area of the survival crafts stowage, with indication of embarkation ports and means of their securing;
 - details of life saving appliances and equipment fastening;
 - distance of the boat from the superstructure's bulkhead;
 - lowering speed of life-saving appliances, [m/min];
 - the course of launching the survival craft at the angle of heel of 0 ° and 20 ° to the opposite side - made on a large scale cross-section in the middle of the length of survival craft, including frame sections of the survival craft and the ship, indicating and identifying the obstacles in the way of survival craft launching;

- .2 calculations and data confirming compliance with the Rules requirements (for review);
- .3 program of the equipment tests after installation on the ship;
- .4 evacuation plan.

3.4 Technical documentation of life-saving appliances for the existing ship subject to alteration or reconstruction

3.4.1 Prior to the commencement of alteration and/or reconstruction of the ship, technical documentation of the equipment and installations being subject of replacement, repairing or alteration is to be submitted to PRS Head Office for consideration and approval.

3.4.2 In the case of installation on the ship in service a new equipment, covered by the requirements of the *Rules* and differing substantially from the existing equipment, the installation documentation for this equipment, in the scope required for new constructed ship (see 3.3.1), is to be submitted to PRS Head Office for consideration and approval.

3.5 Life-saving appliances for the new ship

3.5.1 The requirements of sub-chapter 3.5 applies to new naval ships indicated in paragraph 2.1.7 (NIE MA TAKIEGO PUNKTU) of the *Part I – Classification Regulations*.

In paragraphs 3.5.2 i 3.5.3 general requirements for small ships are set down. For the ships of displacement below 40 t deviations, on the basis of PRS individual consideration, are possible.

Paragraphs 3.5.4 to 3.5.8 include the requirements for various types of the naval ships.

3.5.2 Radio life-saving appliances

The requirements of 3.5.2.1 and 3.5.2.2 apply to all ships of displacement 300 t and upwards.

3.5.2.1 Two-way radiotelephone apparatus

On every ship of displacement 500 t and upwards at least 3 two-way VHF radio telephone apparatus shall be provided.

Every ship of displacement 300 t and upwards, but less than 500 t, shall be provided with at least 2 two-way VHF radio telephone apparatus. Such apparatus shall conform to performance standards not inferior to those adopted by IMO¹⁾.

If a fixed two-way radio apparatus is fitted in a survival craft it shall conform to performance standards not inferior to those adopted by IMO¹⁾.

¹⁾ See Res..A.809(19): Performance standards for survival craft two-way VHF radiotelephone apparatus.

3.5.2.2 Radar transponders

At least one radar transponder shall be carried on each side of every ship of displacement 500 t and upwards.

Every ship of displacement 300 t and upwards, but less than 500 t, shall be provided with at least one radar transponder.

Such radar transponders shall conform to performance standards not inferior to those adopted by IMO¹.

The radar transponders shall be stowed in such location that they can be rapidly placed in any survival craft other than the liferaft.

3.5.3 Equipment for ships up to 100 gross tonnage

3.5.3.1 Personal life-saving appliances

3.5.3.1.1 Lifebuoys

3.5.3.1.1.1 At least 6 lifebuoys complying with the requirements of sub-chapter 2.1 of the *LSA Code*, shall be:

- .1** so distributed as to be readily available on both sides of the ship and, as far as practicable, on all open decks extending to the ship's side; at least one shall be placed in the vicinity of stern;
- .2** so stowed as to be capable of being rapidly cast lose, and not permanently secured in any way.

3.5.3.1.1.2 At least one lifebuoy on each side of the ship shall be fitted with a buoyant life complying with the requirements of paragraph 2.1.4 of the *LSA Code*, equal in length to not less than twice the height at which it is stowed above the waterline in the lightest seagoing condition, or 30 m, whichever is the greater.

3.5.3.1.1.3 Not less than one half of the total number of lifebuoys shall be provided with lifebuoy self-igniting lights complying with the requirements of paragraph 2.1.2 of *the Code*; not less than two of these shall also be provided with lifebuoy self-activating smoke signals complying with the requirements of paragraph 2.1.3 of *the Code* and be capable of quick release from the navigation bridge; lifebuoys with lights and those with lights and smoke signals shall be equally distributed on both sides of the ship and shall not be the lifebuoys provided with lifelines in compliance with the requirements of paragraph 3.5.3.1.1.2.

3.5.3.1.1.4 Each lifebuoy shall be marked in block capitals of the Roman alphabet with the name and port of registry of the ship on which it is carried.

3.5.3.1.2 Lifejackets

3.5.3.1.2.1 A lifejacket complying with the requirements of paragraph 2.2.1 or 2.2.2 of the Code shall be provided for every person on board the ship and, in addition:

¹ See rez. A.809(19)

- .1 a sufficient number of lifejackets shall be carried for persons on watch and for use at remotely located survival craft stations.

3.5.3.1.2.2 Lifejackets shall be so placed as to be readily accessible and their position shall be plainly indicated.

3.5.3.1.3 Immersion suits and anti-exposure suits

An immersion suit, complying with the requirements of section 2.3 of *the Code* or an anti-exposure suit complying with section 2.4 of *the Code*, of an appropriate size, shall be provided for every person assigned to crew the rescue boat.

3.5.3.1.4 Line-throwing appliances

The ship shall be provided with a line-throwing appliance complying with the requirements of sub-paragraph 7.1 of *the Code*.

3.5.3.2 Survival craft and rescue boats

3.5.3.2.1 Liferrafts

Every ship shall carry at least two liferafts of aggregate capacity as will accommodate the total number of persons on board. If the liferafts are not stowed in a position providing for easy side-to-side transfer, the total capacity available on each side shall be sufficient to accommodate the total number of persons on board.

3.5.3.2.2 Rescue boats

- .1 The ship carrying more than 4 liferafts shall be provided with at least one rescue boat complying with the requirements of sub-chapter 5.1 of the *Code*.
- .2 Attempt and working boats may be accepted as a rescue boats provided that they comply with the requirements of sub-chapter 5.1 of the *Code*.

3.5.4 Minesweepers/mine destroyers

3.5.4.1 Personal life-saving appliances

3.5.4.1.1 Lifebuoys

3.5.4.1.1.1 At least 6 lifebuoys complying with the requirements of sub-chapter 2.1 of *the Code*, shall be:

- .1 so distributed as to be readily available on both sides of the ship and, as far as practicable, on all open decks extending to the ship's side; at least one shall be placed in the vicinity of stern;
- .2 so stowed as to be capable of being rapidly cast lose, and not permanently secured in any way.

3.5.4.1.1.2 At least one lifebuoy on each side of the ship shall be fitted with a buoyant life complying with the requirements of paragraph 2.1.4 of the *LSA Code*, equal in length to not less than twice the height at which it is stowed above the waterline in the lightest seagoing condition, or 30 m, whichever is the greater.

3.5.4.1.1.3 Not less than one half of the total number of lifebuoys shall be provided with lifebuoy self-igniting lights complying with the requirements of paragraph 2.1.2 of *the Code*; not less than two of these shall also be provided with lifebuoy self-activating smoke signals complying with the requirements of paragraph 2.1.3 of *the Code* and be capable of quick release from the navigation bridge; lifebuoys with lights and those with lights and smoke signals shall be equally distributed on both sides of the ship and shall not be the lifebuoys provided with lifelines in compliance with the requirements of paragraph 3.5.4.1.1.2.

3.5.4.1.1.4 Each lifebuoy shall be marked in block capitals of the Roman alphabet with the name and port of registry of the ship on which it is carried.

3.5.4.1.2 Lifejackets

3.5.4.1.2.1 A lifejacket complying with the requirements of paragraph 2.2.1 or 2.2.2 of the Code shall be provided for every person on board the ship and, in addition:

- .1 a sufficient number of lifejackets shall be carried for persons on watch and for use at remotely located survival craft stations.

3.5.4.1.2.2 Lifejackets shall be so placed as to be readily accessible and their position shall be plainly indicated.

3.5.4.1.3 Immersion suits and anti-exposure suits

An immersion suit, complying with the requirements of section 2.3 of *the Code* or an anti-exposure suit complying with section 2.4 of *the Code*, of an appropriate size, shall be provided for every person assigned to crew the rescue boat. On ships engaged on international voyages immersion suit shall be provided for every person on board.

3.5.4.1.4 Line-throwing appliances

The ship shall be provided with a line-throwing appliance complying with the requirements of sub-paragraph 7.1 of *the Code*.

3.5.4.2 Survival crafts and rescue boats

3.5.4.2.1 Liferafts

Every ship shall carry at least two liferafts of aggregate capacity as will accommodate the total number of persons on board. If the liferafts are not stowed in a position providing for easy side-to-side transfer, the total capacity available on each side shall be sufficient to accommodate the total number of persons on board.

3.5.4.2.2 Rescue boats

The ship carrying more than 4 liferafts shall be provided with at least one rescue boat complying with the requirements of sub-chapter 5.1 of *the Code*.

3.5.5 Ships of 100 t to 600 t

3.5.5.1 Personal life-saving appliances

3.5.5.1.1 Lifebuoys

3.5.5.1.1.1 At least 8 lifebuoys complying with the requirements of sub-chapter 2.1 of *the Code*, shall be:

- .1** so distributed as to be readily available on both sides of the ship and, as far as practicable, on all open decks extending to the ship's side; at least one shall be placed in the vicinity of stern;
- .2** so stowed as to be capable of being rapidly cast lose, and not permanently secured in any way.

3.5.5.1.1.2 At least one lifebuoy on each side of the ship shall be fitted with a buoyant life complying with the requirements of paragraph 2.1.4 of *the Code*, equal in length to not less than twice the height at which it is stowed above the waterline in the lightest seagoing condition, or 30 m, whichever is the greater.

3.5.5.1.1.3 Not less than one half of the total number of lifebuoys shall be provided with lifebuoy self-igniting lights complying with the requirements of paragraph 2.1.2 of *the Code*; not less than two of these shall also be provided with lifebuoy self-activating smoke signals complying with the requirements of paragraph 2.1.3 of *the Code* and be capable of quick release from the navigation bridge; lifebuoys with lights and those with lights and smoke signals shall be equally distributed on both sides of the ship and shall not be the lifebuoys provided with lifelines in compliance with the requirements of paragraph 3.5.4.1.1.2.

3.5.5.1.1.4 Each lifebuoy shall be marked in block capitals of the Roman alphabet with the name and port of registry of the ship on which it is carried.

3.5.5.1.2 Lifejackets

3.5.5.1.2.1 A lifejacket complying with the requirements of paragraph 2.2.1 or 2.2.2 of the Code shall be provided for every person on board the ship and, in addition:

- .1** a sufficient number of lifejackets shall be carried for persons on watch and for use at remotely located survival craft stations;
- .2** lifejackets shall be so placed as to be readily accessible and their position shall be plainly indicated.

3.5.5.1.3 Immersion suits and anti-exposure suits

An immersion suit, complying with the requirements of section 2.3 of *the Code* or an anti-exposure suit complying with section 2.4 of *the Code*, of an appropriate size, shall be provided for every person assigned to crew the rescue boat. On ships engaged on international voyages immersion suit shall be provided for every person on board.

3.5.5.1.4 Line-throwing appliances

The ship shall be provided with a line-throwing appliance complying with the requirements of sub-paragraph 7.1 of *the Code*.

3.5.5.2 Survival crafts and rescue boats

3.5.5.2.1 Liferafts

Every ship shall carry at least two liferafts of aggregate capacity as will accommodate the total number of persons on board. If the liferafts are not stowed in a position providing for easy side-to-side transfer, the total capacity available on each side shall be sufficient to accommodate the total number of persons on board..

3.5.5.2.2 Rescue boats

The ship shall carry at least one rescue boat complying with the requirements of sub-paragraph 5.1 of *the Code*.

3.5.6 Equipment of the corvette class ship

3.5.6.1 Personal life-saving appliances

3.5.6.1.1 Lifebuoys

3.5.6.1.1.1 At least 8 lifebuoys complying with the requirements of sub-chapter 2.1 of the *LSA Code*, shall be:

- .1** so distributed as to be readily available on both sides of the ship and, as far as practicable, on all open decks extending to the ship's side; at least one shall be placed in the vicinity of stern;
- .2** so stowed as to be capable of being rapidly cast lose, and not permanently secured in any way.

3.5.6.1.1.2 At least one lifebuoy on each side of the ship shall be fitted with a buoyant life complying with the requirements of paragraph 2.1.4 of *the Code*, equal in length to not less than twice the height at which it is stowed above the waterline in the lightest seagoing condition, or 30 m, whichever is the greater.

3.5.6.1.1.3 Not less than one half of the total number of lifebuoys shall be provided with lifebuoy self-igniting lights complying with the requirements of paragraph 2.1.2 of *the Code*; not less than two of these shall also be provided with lifebuoy self-activating smoke signals complying with the requirements of paragraph 2.1.3 of the Code and be capable of quick release from the navigation bridge; lifebuoys

with lights and those with lights and smoke signals shall be equally distributed on both sides of the ship and shall not be the lifebuoys provided with lifelines in compliance with the requirements of paragraph 3.5.4.1.1.2.

3.5.6.1.1.4 Each lifebuoy shall be marked in block capitals of the Roman alphabet with the name and port of registry of the ship on which it is carried.

3.5.6.1.1.5 Every ship shall be provided with lifebuoys complying with the requirements of sub-paragraph 2.1 of *the Code*, but in the number not less than prescribed in the Table 3.5.6.1.1.5:

Tabela 3.5.6.1.1.5

Length of the ship L , [m]	Minimum number of the lifeboats
$L < 100$	8
$100 \leq L < 150$	10

3.5.6.1.2 Lifejackets

A lifejacket complying with the requirements of paragraph 2.2.1 or 2.2.2 of the *Code* shall be provided for every person on board the ship and, in addition:

- .1 a sufficient number of lifejackets shall be carried for persons on watch and for use at remotely located survival craft stations.;
- .2 lifejackets shall be so placed as to be readily accessible and their position shall be plainly indicated. Lifejackets shall be so placed as to be readily accessible and their position shall be plainly indicated. If, due to the specific design features of the ship belts provided for in 3.5.6.1.2.1 could become inaccessible, alternative solutions, accepted by the PRS, should be applied, which may include increasing the number of lifejackets located on the ship.

3.5.6.1.3 Immersion suits and anti-exposure suits

An immersion suit, complying with the requirements of section 2.3 of *the Code* or an anti-exposure suit complying with section 2.4 of *the Code*, of an appropriate size, shall be provided for every person assigned to crew the rescue boat.

3.5.6.1.4 Line-throwing appliances

The ship shall be provided with a line-throwing appliance complying with the requirements of sub-paragraph 7.1 of *the Code*.

3.5.6.2 Survival crafts and rescue boats

3.5.6.2.1 Survival crafts

3.5.6.2.1.1 The ship shall carry:

- .1 one or more lifeboats complying with the requirements of section 4.6 of the *Code* of such aggregate capacity on each side of the ship as will accommodate the total number of persons on board; and
- .2 in addition, one or more inflatable or rigid liferafts, complying with the requirements of section 4.2 or 4.3 of the *Code*, stowed in a position providing for

easy side-to-side transfer at a single open deck level, and of such aggregate capacity as will accommodate the total number of persons on board. If the liferaft or liferafts are not stowed in a position providing for easy side-to-side transfer at a single open deck level, the total capacity available on each side shall be sufficient to accommodate the total number of persons on board.

3.5.6.2.1.2 In lieu of meeting the requirements of paragraph 3.5.6.2.1.1, the ship of length less than 85 m, may comply with the following:

- .1 they shall carry on each side of the ship, inflatable or rigid liferafts complying with the requirements of section 4.2 or 4.3 of the Code and of such aggregate capacity as will accommodate the total number of persons on board;
- .2 unless the liferafts required by paragraph .1 are stowed in a position providing for easy side-to-side transfer at a single open deck level, additional liferafts shall be provided so that the total capacity available on each side will accommodate 150% of the total number of persons on board;
- .3 if the rescue boat required by paragraph 3.5.6.2.2 is also a partially or totally enclosed lifeboat complying with the requirements of section 4.6 of *the Code*, it may be included in the aggregate capacity required by paragraph .1, provided that the total capacity available on either side of the ship is at least 150% of the total number of persons on board; and
- .4 in the event of any one survival craft being lost or rendered unseaworthy, there shall be sufficient survival craft available for use on each side, including those which are stowed in a position providing for easy side-to-side transfer at a single open deck level, to accommodate the total number of persons on board.

3.5.6.2.1.3 All survival craft required to provide for abandonment by the total number of persons on board shall be capable of being launched with their full complement of persons and equipment within a period of 30 min from the time the abandon ship signal is given.

3.5.6.2.2 Rescue boats

The ship shall carry at least one rescue boat complying with the requirements of sub-paragraph 5.1 of *the Code*.

3.5.7 Equipment of the frigate class ship

3.5.7.1 Personal life-saving appliances

3.5.7.1.1 Lifebuoys

3.5.7.1.1.1 Lifebuoys complying with the requirements of sub-chapter 2.1 of the *LSA Code*, shall be:

- .1 so distributed as to be readily available on both sides of the ship and, as far as practicable, on all open decks extending to the ship's side; at least one shall be placed in the vicinity of stern;
- .2 so stowed as to be capable of being rapidly cast loose, and not permanently secured in any way.

3.5.7.1.1.2 Not less than one half of the total number of lifebuoys shall be provided with lifebuoy self-igniting lights complying with the requirements of paragraph 2.1.2 of *the Code*; not less than two of these shall also be provided with lifebuoy self-activating smoke signals complying with the requirements of paragraph 2.1.3 of *the Code* and be capable of quick release from the navigation bridge; lifebuoys with lights and those with lights and smoke signals shall be equally distributed on both sides of the ship and shall not be the lifebuoys provided with lifelines in compliance with the requirements of paragraph 3.5.4.1.1.2.

3.5.7.1.1.3 Each lifebuoy shall be marked in block capitals of the Roman alphabet with the name and port of registry of the ship on which it is carried.

3.5.7.1.1.4 Every ship shall be provided with lifebuoys complying with the requirements of sub-paragraph 2.1 of *the Code*, but in the number not less than prescribed in the Table 3.5.7.1.1.4:

Table 3.5.7.1.1.4

Length of the ship L , [m]	Minimum number of the lifebuoys
$L < 100$	8
$100 \leq L < 150$	10

3.5.7.1.2 Lifejackets

3.5.7.1.2.1 A lifejacket complying with the requirements of paragraph 2.2.1 or 2.2.2 of the Code shall be provided for every person on board the ship and, in addition:

- .1 a sufficient number of lifejackets shall be carried for persons on watch and for use at remotely located survival craft stations.

3.5.7.1.2.2 Lifejackets shall be so placed as to be readily accessible and their position shall be plainly indicated. Lifejackets shall be so placed as to be readily accessible and their position shall be plainly indicated. If, due to the specific design features of the ship belts provided for in 3.5.7.1.2.1 could become inaccessible, alternative solutions, accepted by the PRS, should be applied, which may include increasing the number of lifejackets located on the ship.

3.5.7.1.2.3 The lifejackets used in totally enclosed lifeboats shall not impede entry into the lifeboat or seating, including operation of the seat belts in the lifeboat.

3.5.7.1.3 Immersion suits and anti-exposure suits

An immersion suit, complying with the requirements of section 2.3 of *the Code* or an anti-exposure suit complying with section 2.4 of *the Code*, of an appropriate size, shall be provided for every person assigned to crew the rescue boat.

3.5.7.1.4 Line-throwing appliances

The ship shall be provided with a line-throwing appliance complying with the requirements of sub-paragraph 7.1 of *the Code*.

3.5.7.2 Survival crafts and rescue boats

3.5.7.2.1 Survival crafts

3.5.7.2.1.1 The ship shall carry:

- .1** one or more lifeboats complying with the requirements of section 4.6 of *the Code* of such aggregate capacity on each side of the ship as will accommodate the total number of persons on board; and
- .2** in addition, one or more inflatable or rigid liferafts, complying with the requirements of section 4.2 or 4.3 of *the Code*, stowed in a position providing for easy side-to-side transfer at a single open deck level, and of such aggregate capacity as will accommodate the total number of persons on board. If the liferaft or liferafts are not stowed in a position providing for easy side-to-side transfer at a single open deck level, the total capacity available on each side shall be sufficient to accommodate the total number of persons on board

3.5.7.2.1.2 All survival craft required to provide for abandonment by the total number of persons on board shall be capable of being launched with their full complement of persons and equipment within a period of 30 min from the time the abandon ship signal is given.

3.5.7.2.2 Rescue boats

The ship shall carry at least one rescue boat complying with the requirements of sub-paragraph 5.1 of *the Code*. A life boat may be accepted as a rescue boat provided it also complies with the requirements for a rescue boat.

3.5.8 Equipment of the landing craft class ship

3.5.8.1 Personal life-saving appliances

3.5.8.1.1 Lifebuoys

3.5.8.1.1.1 Lifebuoys complying with the requirements of sub-chapter 2.1 of *the Code*, shall be:

- .1** so distributed as to be readily available on both sides of the ship and, as far as practicable, on all open decks extending to the ship's side; at least one shall be placed in the vicinity of stern;
- .2** so stowed as to be capable of being rapidly cast lose, and not permanently secured in any way.

3.5.8.1.1.2 Not less than one half of the total number of lifebuoys shall be provided with lifebuoy self-igniting lights complying with the requirements of paragraph 2.1.2 of *the Code*; not less than two of these shall also be provided with lifebuoy self-activating smoke signals complying with the requirements of paragraph 2.1.3 of *the Code* and be capable of quick release from the navigation bridge; lifebuoys with lights and those with lights and smoke signals shall be equally distrib-

uted on both sides of the ship and shall not be the lifebuoys provided with lifelines in compliance with the requirements of paragraph 3.5.4.1.1.2.

3.5.8.1.1.3 Each lifebuoy shall be marked in block capitals of the Roman alphabet with the name and port of registry of the ship on which it is carried.

3.5.8.1.1.4 Every ship shall be provided with lifebuoys complying with the requirements of sub-paragraph 2.1 of *the Code*, but in the number not less than prescribed in the Table 3.5.8.1.1.4:

Tabela 3.5.8.1.1.4

Length of the ship L , [m]	Minimum number of the lifebuoys
$L < 100$	8
$100 \leq L < 150$	10

3.5.8.1.2 Lifejackets

3.5.8.1.2.1 A lifejacket complying with the requirements of paragraph 2.2.1 or 2.2.2 of the Code shall be provided for every person on board the ship and, in addition:

- .1 a sufficient number of lifejackets shall be carried for persons on watch and for use at remotely located survival craft stations.

3.5.8.1.2.2 Lifejackets shall be so placed as to be readily accessible and their position shall be plainly indicated. If, due to the specific design features of the ship belts provided for in 3.5.8.1.2.1 could become inaccessible, alternative solutions, accepted by the PRS, should be applied, which may include increasing the number of lifejackets located on the ship.

3.5.8.1.2.3 The lifejackets used in totally enclosed lifeboats shall not impede entry into the lifeboat or seating, including operation of the seat belts in the lifeboat.

3.5.8.1.3 Immersion suits and anti-exposure suits

An immersion suit, complying with the requirements of section 2.3 of *the Code* or an anti-exposure suit complying with section 2.4 of *the Code*, of an appropriate size, shall be provided for every person assigned to crew the rescue boat.

3.5.8.1.4 Line-throwing appliances

The ship shall be provided with a line-throwing appliance complying with the requirements of sub-paragraph 7.1 of *the Code*.

3.5.8.2 Survival crafts and rescue boats

3.5.8.2.1 Survival crafts

3.5.8.2.1.1 The ship shall carry::

- .1 one or more lifeboats complying with the requirements of section 4.6 of *the Code* of such aggregate capacity on each side of the ship as will accommodate the total number of persons on board; and
- .2 in addition, one or more inflatable or rigid liferafts, complying with the requirements of section 4.2 or 4.3 of *the Code*, stowed in a position providing for easy side-to-side transfer at a single open deck level, and of such aggregate capacity as will accommodate the total number of persons on board. If the liferaft or liferafts are not stowed in a position providing for easy side-to-side transfer at a single open deck level, the total capacity available on each side shall be sufficient to accommodate the total number of persons on board

3.5.8.2.1.2 In lieu of meeting the requirements of paragraph 3.5.8.2.1.1, the ship of length less than 85 m, may comply with the following:

- .1 they shall carry on each side of the ship, inflatable or rigid liferafts complying with the requirements of section 4.2 or 4.3 of the Code and of such aggregate capacity as will accommodate the total number of persons on board;
- .2 unless the liferafts required by paragraph .1 are stowed in a position providing for easy side-to-side transfer at a single open deck level, additional liferafts shall be provided so that the total capacity available on each side will accommodate 150% of the total number of persons on board;
- .3 if the rescue boat required by paragraph 3.5.8.2.2 is also a partially or totally enclosed lifeboat complying with the requirements of section 4.6 of *the Code*, it may be included in the aggregate capacity required by paragraph .1, provided that the total capacity available on either side of the ship is at least 150% of the total number of persons on board; and
- .4 in the event of any one survival craft being lost or rendered unseaworthy, there shall be sufficient survival craft available for use on each side, including those which are stowed in a position providing for easy side-to-side transfer at a single open deck level, to accommodate the total number of persons on board.

3.5.8.2.1.3 All survival craft required to provide for abandonment by the total number of persons on board shall be capable of being launched with their full complement of persons and equipment within a period of 30 min from the time the abandon ship signal is given.

3.5.8.2.2 Rescue boats

The ship shall carry at least one rescue boat complying with the requirements of sub-paragraph 5.1 of *the Code*. A life boat may be accepted as a rescue boat provided it also complies with the requirements for a rescue boat.

3.5.9 Equipment of the supply vessel class ship

3.5.9.1 Personal life-saving appliances

3.5.9.1.1 Lifebuoys

3.5.9.1.1.1 Lifebuoys complying with the requirements of sub-chapter 2.1 of the *LSA Code*, shall be:

- .1 so distributed as to be readily available on both sides of the ship and, as far as practicable, on all open decks extending to the ship's side; at least one shall be placed in the vicinity of stern;
- .2 so stowed as to be capable of being rapidly cast lose, and not permanently secured in any way.

3.5.9.1.1.2 Not less than one half of the total number of lifebuoys shall be provided with lifebuoy self-igniting lights complying with the requirements of paragraph 2.1.2 of *the Code*; not less than two of these shall also be provided with lifebuoy self-activating smoke signals complying with the requirements of paragraph 2.1.3 of *the Code* and be capable of quick release from the navigation bridge; lifebuoys with lights and those with lights and smoke signals shall be equally distributed on both sides of the ship and shall not be the lifebuoys provided with lifelines in compliance with the requirements of paragraph 3.5.4.1.1.2.

3.5.9.1.1.3 Each lifebuoy shall be marked in block capitals of the Roman alphabet with the name and port of registry of the ship on which it is carried.

3.5.9.1.1.4 Every ship shall be provided with lifebuoys complying with the requirements of sub-paragraph 2.1 of *the Code*, but in the number not less than prescribed in the Table 3.5.9.1.1.4:

Tabela 3.5.9.1.1.4

Length of the ship L , [m]	Minimum number of the lifebuoys
$L < 100$	8
$100 \leq L < 150$	10

3.5.9.1.2 Lifejackets

3.5.9.1.2.1 **3.5.9.1.2.1A** lifejacket complying with the requirements of paragraph 2.2.1 or 2.2.2 of the *Code* shall be provided for every person on board the ship and, in addition:

- .1 a sufficient number of lifejackets shall be carried for persons on watch and for use at remotely located survival craft stations.

3.5.9.1.2.2 Lifejackets shall be so placed as to be readily accessible and their position shall be plainly indicated. Lifejackets shall be so placed as to be readily accessible and their position shall be plainly indicated. If, due to the specific design

features of the ship belts provided for in 3.5.9.1.2.1 could become inaccessible, alternative solutions, accepted by the PRS, should be applied, which may include increasing the number of lifejackets located on the ship.

3.5.9.1.2.3 Pasy ratunkowe używane w całkowicie zakrytych łodziach ratunkowych nie powinny utrudniać wejścia do łodzi lub siedzenia w niej, łącznie z zapięciem pasów bezpieczeństwa.

3.5.9.1.3 Immersion suits and anti-exposure suits

An immersion suit, complying with the requirements of section 2.3 of *the Code* or an anti-exposure suit complying with section 2.4 of *the Code*, of an appropriate size, shall be provided for every person assigned to crew the rescue boat.

3.5.9.1.4 Line-throwing appliances

The ship shall be provided with a line-throwing appliance complying with the requirements of sub-paragraph 7.1 of *the Code*.

3.5.9.2 Survival crafts and rescue boats

3.5.9.2.1 Survival crafts

3.5.9.2.1.1 The ship shall carry:

- .1** one or more lifeboats complying with the requirements of section 4.6 of *the Code* of such aggregate capacity on each side of the ship as will accommodate the total number of persons on board; and
- .2** in addition, one or more inflatable or rigid liferafts, complying with the requirements of section 4.2 or 4.3 of *the Code*, stowed in a position providing for easy side-to-side transfer at a single open deck level, and of such aggregate capacity as will accommodate the total number of persons on board. If the liferaft or liferafts are not stowed in a position providing for easy side-to-side transfer at a single open deck level, the total capacity available on each side shall be sufficient to accommodate the total number of persons on board

3.5.9.2.1.2 In lieu of meeting the requirements of paragraph 3.5.9.2.1.1, the ship of length less than 85 m, may comply with the following:

- .1** they shall carry on each side of the ship, inflatable or rigid liferafts complying with the requirements of section 4.2 or 4.3 of the Code and of such aggregate capacity as will accommodate the total number of persons on board;
- .2** unless the liferafts required by paragraph .1 are stowed in a position providing for easy side-to-side transfer at a single open deck level, additional liferafts shall be provided so that the total capacity available on each side will accommodate 150% of the total number of persons on board;

- .3 if the rescue boat required by paragraph 3.5.9.2.2 is also a partially or totally enclosed lifeboat complying with the requirements of section 4.6 of *the Code*, it may be included in the aggregate capacity required by paragraph .1, provided that the total capacity available on either side of the ship is at least 150% of the total number of persons on board; and
- .4 in the event of any one survival craft being lost or rendered unserviceable, there shall be sufficient survival craft available for use on each side, including those which are stowed in a position providing for easy side-to-side transfer at a single open deck level, to accommodate the total number of persons on board.

3.5.9.2.1.3 All survival craft required to provide for abandonment by the total number of persons on board shall be capable of being launched with their full complement of persons and equipment within a period of 30 min from the time the abandon ship signal is given..

3.5.9.2.2 Rescue boats

The ship shall carry at least one rescue boat complying with the requirements of sub-paragraph 5.1 of *the Code*. A life boat may be accepted as a rescue boat provided it also complies with the requirements for a rescue boat.

3.6 The requirements for life-saving equipment

Life-saving equipment shall comply with the requirements *the Code*, and in addition with the requirements of the present sub-chapter.

3.6.1 Inflatable liferafts

3.6.1.1 Inflatable liferafts shall comply with the requirements of sub-chapter 4.2 of *the Code*..

3.6.1.2 Inflatable liferaft shall be provided with a self-draining device.

3.6.1.3 On the liferaft's container shall be placed marking concerning applied float-free system.

3.6.2 Canopied reversible liferafts

3.6.2.1 Canopied reversible liferafts shall comply with the requirements of sub-chapter 4.1 of *the Code*, in the case of inflatable liferafts 4.2 of *the Code*, and in the case of rigid liferafts – sub-chapter 4.3 of *the Code*, and in addition with the provisions of the present sub-chapter.

3.6.2.2 The requirements of paragraphs 4.2.5.2 i 4.2.6.2 of *the Code* do not apply to the pneumatic canopied reversible liferafts, and the requirements of paragraph 4.3.5.1 of *the Code* – to rigid canopied reversible liferafts. Floating canopied reversible liferaft shall be provided with the self-draining device. The liferaft shall be so constructed that it can be used safely by non-trained persons.

3.6.2.3 Canopied reversible liferaft shall be effective irrespective its position after launching.

The liferaft shall be provided with the canopy on both sides. *Tratwa powinna posiadać namiot po każdej z obu jej stron.* The canopy shall automatically set in place when the liferaft is launched and waterborne.

3.6.2.4 Both tents shall comply with the requirements of paragraphs 4.1.1.5, 4.1.3.3 i 4.1.3.4 of *the Code*.

3.6.2.5 The liferaft's equipment required in the sub-paragraph 4.1.5 of *the Code* shall be readily accessible for use irrespective of the side, on which the liferaft is floating.

3.6.2.6 Fully equipped canopied reversible liferaft shall in sea conditions remain its right position irrespective of its load.

3.6.2.7 Canopied reversible liferaft does not need to comply with the requirement concerning easy transfer from side to side of the ship therefore its weight does not to be limited to 185 kg required in paragraph 4.1.2.2 of *the Code*.

3.6.3 Self-righting liferafts

3.6.3.1 Self-righting liferafts shall comply with the requirements of the sub-chapter 4.1 of *the Code* and, in the case of inflatable liferafts – of the sub-chapter 4.2 of *the Code*, and in the case of rigid liferafts – of the sub-chapter 4.3 of *the Code*, while:

- .1 the requirements of paragraphs 4.2.5.2 i 4.2.6.2 of *the Code* do not apply to the pneumatic self-righting liferafts, and the requirements of paragraph 4.3.5.1 of *the Code* – to rigid self-righting liferafts;
- .2 fully equipped self-righting liferaft shall be automatically set in upright position irrespective of the position in which it was inflated;
- .3 floating self-righting liferaft shall be provided with the self-draining device. The liferaft shall be so constructed that it can be used safely by non-trained persons;
- .4 self-righting liferaft does not need to comply with the requirement concerning easy transfer from side to side of the ship therefore its weight does not to be limited to 185 kg required in paragraph 4.1.2.2 of *the Code*.

3.6.4 Open reversible liferafts

3.6.4.1 Open reversible liferafts shall comply with the requirements of paragraphs 4.1.1.4, 4.1.3.1, 4.2.2.1 i 4.2.6.1 of *the Code* and, additionally, with the following requirements:

- .1 shall be of adequate quality and made of adequate materials;
- .2 shall be resistant to marine atmosphere during storage at ambient temperature in the range of $-18\text{ }^{\circ}\text{C}$ to $+65\text{ }^{\circ}\text{C}$;

- .3 shall be operable properly at the air temperatures within the range of -18°C do $+65^{\circ}\text{C}$ and the sea water temperatures within the range of -1°C to $+30^{\circ}\text{C}$;
- .4 shall be so constructed that when fully inflated and loaded remains stable.

3.6.4.2 Construction of open reversible liferafts

3.6.4.2.1 The liferaft shall be so constructed that when it is dropped into the water from a height of 10 m, the liferaft and its equipment will operate satisfactorily.

If the liferaft is to be stowed at a height of more than 10 m above the waterline in the lightest seagoing condition, it shall be of a type which has been satisfactorily drop-tested from at least that height.

3.6.4.2.2 The floating liferaft shall be capable of withstanding repeated jumps on to it from a height of at least 4.5 m above its floor.

3.6.4.2.3 When the liferaft is fully inflated it shall be possible to enter it whatever position it takes after inflation.

3.6.4.2.4 The floor of the liferaft shall be waterproof.

3.6.4.2.5 The liferaft shall be inflated with a non-toxic gas. Inflation shall be completed within a period of 1 min at an ambient temperature of between 18°C and 20°C and within a period of 3 min at an ambient temperature of -18°C . After inflation, the liferaft shall maintain its form when loaded with its full complement of persons and equipment.

3.6.4.2.6 Each inflatable compartment shall be capable of withstanding a pressure equal to at least three times the working pressure and shall be prevented from reaching a pressure exceeding twice the working pressure either by means of relief valves or by a limited gas supply. Means shall be provided for fitting the topping-up pump or bellows so that the working pressure can be maintained.

3.6.4.2.7 Buoyancy chambers shall have clearly visible colour on at least 25 % of their surface. The compliance may be achieved by application of material for water pockets with clearly visible colour.

3.6.4.2.8 Surfaces of the buoyancy chambers shall be made as anti-skid.

3.6.4.3 Carrying capacity of the liferafts

3.6.4.3.1 The number of persons which a liferaft shall be permitted to accommodate shall be equal to the lesser of:

- .1 the greatest whole number obtained by dividing by 0,075 (0,096)¹⁾ the volume, measured in cubic metres, of the main buoyancy tubes (which for this

¹⁾ Value 0,096 concerns the high speed crafts (HSC).

purpose shall include neither the arches nor the thwarts, if fitted) when inflated; or

- .2 the greatest whole number obtained by dividing by 0,304 (0,372)²⁾ the inner horizontal cross-sectional area of the liferaft measured in square metres (which for this purpose may include the thwart or thwarts, if fitted) measured to the innermost edge of the buoyancy tubes; or
- .3 the number of persons having an average mass of 75 kg, all wearing either immersion suits and lifejackets or, in the case of davit-launched liferafts, lifejackets, that can be seated with sufficient comfort and headroom without interfering with the operation of any of the liferaft's equipment.

3.6.4.3.2 The liferaft capacity shall not be less than 4 persons.

3.6.4.4 Liferafts equipment

3.6.4.4.1 The liferaft shall be fitted with an efficient painter so arranged, that self-inflation starts during liferaft's descent before its reaching the water. The liferafts of capacity more than 30 persons shall, additionally, be provided with bowing line.

3.6.4.4.2 The breaking strength of the painter system, including its means of attachment to the liferaft, except the weak link required by the paragraph 4.1.6.2 of *the Code*, shall not be less than:

- 7,5 kN for liferafts accommodating up to 8 persons,
- 10,0 kN for liferafts accommodating from 9 to 30 persons, and
- 15,0 kN for liferafts accommodating more than 30 persons.

3.6.4.4.3 The liferaft shall be provided with the following number of semi-rigid boarding ramps to enable persons to board the liferaft from the sea, irrespective which side it falls onto water:

- .1 one for the liferafts accommodating up to 30 persons,
- .2 two for the liferafts accommodating more than 30 persons.

3.6.4.4.4 The liferaft shall be fitted with water pockets complying with the following requirements:

- .1 pocket section shall be of isosceles triangle shape, and the triangle base shall be attached to the underside of the liferaft;
- .2 the design shall be such that the pockets fill to at least 60% of their capacity within 15-25 s of deployment;
- .3 aggregate capacity of the water pockets shall be from 125 to 150 litres for liferafts accommodating up to 10 persons;

²⁾ Value 0,372 concerns the high speed crafts (HSC).

- .4 aggregate capacity of the water pockets for liferafts designated for more than 10 persons shall be not less than $12n$, [I], where n is the number of persons which the liferaft may accommodate;
- .5 the water pockets shall be fastened outside of the both upper buoyancy chambers;
- .6 the water pockets shall be positioned round the circumference of the liferaft, with sufficient distances between them.

3.6.4.4.5 At least one manually controlled lamp complying with the requirements of paragraph 4.1.3.3 of *the Code* shall be fitted on both sides of the main buoyancy chambers.

3.6.4.4.6 Adequate arrangements for the liferafts' floor self-draining shall be provided:

- for the liferaft accommodating up to 30 persons – one device,
- for the liferaft accommodating more than 30 persons – two devices.

3.6.4.4.7 W skład wyposażenia tratwy ratunkowej powinny wchodzić:

- .1 one buoyant rescue quoit, attached to not less than 30 m of buoyant line of breaking strength not less than 1 kN;
- .2 one knife, and for the liferafts permitted to accommodate 13 or more persons – two such knives;
- .3 buoyant bailer, and for a liferaft which is permitted to accommodate 13 persons or more – two such buoyant bailers;
- .4 two sponges;
- .5 two sea-anchors: one permanently attached to the liferaft deployed automatically when the liferaft inflates, and the other being spare;
- .6 two buoyant paddles;
- .7 one whistle or equivalent sound signal;
- .8 six hand flares complying of the approved type giving a bright red light for a period not less than 1 min;
- .9 one waterproof electric torch suitable for Morse signalling together with one spare set of batteries and one spare bulb;
- .10 one copy of illustrated life-saving signals;
- .11 instruction on survival;
- .12 one first-aid outfit in a waterproof case capable of being closed tightly after use;
- .13 one repair outfit for repairing punctures in buoyancy compartments;
- .14 one topping-up pump or bellows;
- .15 an efficient radar reflector, unless a survival craft radar transponder is stowed in the liferaft.

3.6.4.4.8 The liferafts equipped in accordance of 3.6.4.4.7 shall be marked „UM PACK” in block capitals of the Roman alphabet.

3.6.4.4.9 If necessary the equipment may be placed in a container which shall be either integral part of the liferaft or be attached to it in a reliable manner. The container shall be capable of floating on the water for at least 30 minutes without damage to its contents.

The link fixing the container to the liferaft shall have a breaking load not less than 2 kN or triple weight of the container, depending whichever is the greater.

3.6.4.5 Marking of the open reversible liferafts

3.6.4.5.1 The container shall be marked with:

- .1 maker's name or trade mark;
- .2 serial number;
- .3 PRS S.A., as an approving authority and the number of persons it is permitted to carry;
- .4 „NON-SOLAS REVERSIBLE”;
- .5 „UM PACK”
- .6 date when last serviced;
- .7 length of painter;
- .8 maximum permitted height of stowage above waterline – depending on drop-test height;
- .9 instrukcja wodowania, nadmuchiwania oraz wejścia na tratwę;
- .10 instruction on on-board stowage.

3.6.4.5.2 Na tratwie ratunkowej powinny być następujące napisy:

- .1 maker's name or trade mark;
- .2 serial number;
- .3 date of manufacture (month and year);
- .4 PRS S.A., as an approving authority;
- .5 name and place of servicing station where it was last serviced;
- .6 number of persons it is permitted to accommodate over each entrance in characters not less than 100 mm in height of a colour contrasting with that of the liferaft.

3.6.5 Fast rescue boats

3.6.5.1 Fast rescue boats and their launching arrangements shall be capable of safe launching and recovery under adverse weather conditions in sea conditions.

3.6.5.2 Except as provided by this section, all rescue boats shall comply with the requirements of sub-chapter 5.1 of *the Code* and referred to other sub-chapters and paragraphs of *the Code* with exclusion of paragraphs: 4.4.1.5.3, 4.4.1.6, 4.4.6.8, 4.4.7.2, 5.1.1.3.1, 5.1.1.6 and 5.1.1.10.

3.6.5.3 Length of the fast rescue boat, including its inflatable part or permanent fenders, shall not be less than 6 m and not greater than 8,5 m.

3.6.5.4 The fully equipped boat shall run at a speed of not less than 20 knots with a crew of 3 persons and 8 knots with a full complement of persons.

3.6.5.5 The fast rescue boats shall be self-righting or can be readily righted by not more than two persons.

3.6.5.6 The fast rescue boats shall be self-draining or adapted to prompt draining.

3.6.5.7 The fast rescue boats shall be controlled with a steering wheel from the helmsman position. Emergency control may be implemented directly by means of tiller. Water jet or outboard motor may also be applied for the purpose.

3.6.5.8 In the case of the fast rescue boat capsizing its engine shall be automatically stopped, or stopped by means of emergency stop switch located adjacent to helmsman position.

When the boat is turned to the proper position, every engine shall be capable of being restarted after the emergency stop switch, if used, is put in normal position.

Arrangement of fuel oil and lubricating oil installation shall be such, that after the boat capsizing the quantity of lost fuel or lubricating oil does not exceed 250 ml.

3.6.5.9 The fast rescue boats, as far as practicable, shall be provided with easy and safe in use single-suspension release gear or equivalent arrangement.

3.6.5.10 The structure of the fast rescue boat shall have such strength that the boat suspended on the suspension or the hook can carry a load with a value corresponding to the full set of quadruple mass of the complement of persons and equipment, without permanent deformation after removal of the load.

3.6.5.11 The normal equipment of the fast rescue boat shall include waterproof set of VHF radiocommunication.

3.6.5.12 The fast rescue boat crew shall comprise a helmsman and at least two crews trained and drilled regularly having regard to the Seafarers Training, Certification and Watchkeeping (*STCW*) Code and IMO recommendations¹⁾.

3.6.6 Appliances for launching fast rescue boats

3.6.6.1 Every launching appliance for fast rescue boats shall comply with the requirements of the sub-chapters 6.1.1 i 6.1.2 (with exclusion of paragraph 6.1.2.10) of *the Code*.

3.6.6.2 The launching appliance shall be providing with the device absorbing forces from wave motions during launching and recovery of the fast rescue boat. The absorbing device shall be provided with an elastic element reducing rapid action of forces, and with a damping element reducing accelerations.

¹⁾ See res.A.809(19): Performance standards for survival craft two-way VHF radiotelephone apparatus.

3.6.6.3 A winch shall be equipped with a quick device tensioning a rope with a constant force in all sea conditions in which the fast rescue boat may be used.

3.6.6.4 The winch brake shall work gradually. While launching the fast rescue boat at full speed the brake is suddenly activated, additional deceleration dynamic force shall not exceed launching appliance's working load of more than 50%.

3.6.6.5 Lowering speed of the fully equipped and with complement of persons fast rescue boat shall not be greater than 1 m/s. Irrespective of the requirement of paragraph 6.1.1.9 of *the Code*, the launching appliance shall be capable of recovery the fully equipped fast rescue boat with 6 persons on board at the speed not less than 0,8 m/s. The appliance shall be capable of recovery the fast rescue boat with the maximum number of persons which the boat is approved to accommodate, calculated in accordance with the paragraph 4.4.2.2 of *the Code*.

At least three turns of rope shall remain on the winch drum when the fast rescue boat is lowered into the water, and the ship is the lightest loading condition with trim up to 10 ° and heel 20 ° to either side.

4 REQUIREMENTS RELATING TO SOLAS CONVENTION, CHAPTER IV – RADIOCOMMUNICATIONS

4.1 Application

4.1.1 The present Chapter 4 applies to ships for which, on the basis of the Purchaser decision, relevant requirements of *SOLAS Convention 1974, Chapter IV – Radiocommunications*, are to be complied with.

4.1.2 The present Chapter does not apply to appliances and communication systems designated for commanding the ship and for operational and tactical purposes.

4.1.3 The requirements of Chapter 4 comply with technical requirements contained in the SOLAS Convention 1974, and adopted to it the current amendments concerning radiocommunications for the Global Maritime Distress and Safety System (GMDSS), as well as comply with the applicable technical requirements of IMO Resolutions.

4.1.4 The present chapter sets out the technical requirements for marine radio equipment and determines the scope ships' equipment with these devices, their installation on ships, power supply and assurance of operational readiness.

4.2 Terms and definitions

Digital selective calling (DSC) – a technique using digital codes which enables a radio station to establish contact with, and transfer information to, another station or group of stations, and complying with the relevant recommendations of ITU (ITU-R) Radiocommunication Sector.

INMARSAT – International Mobile Satellite Organization established by the *Convention on the International Maritime Satellite Organization adopted in 1976*.

Global maritime distress and safety system identities – maritime mobile services identity, the ship's call sign, INMARSAT identities and serial number identity which may be transmitted by the ship's equipment and used to identify the ship.

Locating – the finding of ships, aircraft, units or persons in distress.

Bridge-to-bridge communications – safety communications between from the position from which the ships are normally navigated.

International NAVTEX service – the co-ordinated broadcast and automatic reception on 518 kHz of maritime safety information by means of narrow-band direct-printing telegraphy using the English language¹⁾.

Maritime safety information (MSI) – navigational and meteorological warnings, meteorological forecasts and other urgent safety related messages broadcast to ships.

¹⁾ Refer to NAVTEX Manual approved by IMO (IMO Publication IC951E).

Statutory supervision – the supervision in accordance with the requirements set out in the present *Rules*.

Sea area A1 – an area within the radiotelephone coverage of at least one VHF coast station in which continuous DSC alerting is available.

Sea area A2 – an area (excluding area A1) within the radiotelephone coverage of at least one MF coast station in which continuous DSC alerting is available.

Sea area A3 – an area (excluding areas A1 and A2) within the coverage of an INMARSAT geostationary satellite in which continuous DSC alerting is available.

Sea area A4 – an area outside sea areas A1, A2 and A3.

General radiocommunications – operational and public correspondence traffic, other than distress, urgency and safety messages conducted by radio.

Radio Regulations – the Radio Regulations annexed to, or regarded as being annexed to, the most recent *International Telecommunication Convention* which is in force at any time.

Polar orbiting satellite service – a service which is based on polar orbiting satellites COSPAS-SARSAT, which receive and relay distress alerts from satellite EPIRBs and which provide provides their position.

Uninterruptible power supply (UPS) – a system of uninterrupted radio equipment power supply for described period of time, independent from the main and emergency sources of energy.

Narrow-band direct-printing telegraphy NBDP – a technique of automatic telegraphy, complying with relevant recommendations of ITU (ITU-R) Radiocommunication Sector.

4.3 Scope of supervision

4.3.1 Statutory supervision covers design, manufacture, installation and service of the following radio equipment:

- .1** a VHF radio installation for radiotelephone communication and digital selective calling DSC;
- .2** a MF radio installation for radiotelephone communication and digital selective calling DSC;
- .3** a MF/HF for radiotelephone communication, narrow-band direct-printing telegraphy NBDP and digital selective calling DSC;
- .4** ship's earth station for INMARSAT satellite communications;
- .5** a receiver for enhanced group calling system EGC;
- .6** a receiver for NAVTEX navigational and meteorological warnings;
- .7** a satellite emergency position-indicating radio beacon EPIRB;
- .8** a radar transponder SART;
- .9** a portable VHF radiotelephone.

4.3.2 All radio installations fitted in ships under PRS supervision shall be PRS type approved. PRS may consider installations having appropriate certificates and documents issued as a result of compliance with the conformity assessment procedures laid down in Directive 96/98/EC of the European Union, concerning the marine equipment, as equivalent to radio installations supervised according to these provisions.

4.3.3 Technical requirements concerning radio installations not referred to in 4.3.2, as well as requirements concerning their installation in the ship shall be, in each case, separately determined by PRS.

4.3.4 Equivalent installations, which may be installed in lieu of installations indicated in 4.3.2, shall be PRS type approved. Additional condition for the type approval of the equivalent installation is its functional compliance required for the installation referred to in 4.3.2.

4.3.5 Prior to commencement of the ship construction, or installation of a new radiocommunication equipment on board of the existing ship, PRS shall be provided for approval with the listed below technical documentation, in a scope adjusted to the service area:

- .1 technical description of the ship;
- .2 list of the radio installations, their types and manufacturers;
- .3 declaration of the sea areas;
- .4 declaration of the radio installations maintenance methods;
- .5 the main diagrams of the radio installations, type of cables and sources of energy;
- .6 method of grounding of the radio installations;
- .7 calculation of the capacity of the reserve source of electrical energy for the radio installations;
- .8 arrangement of the radio installations on the navigation bridge;
- .9 common plans of antennas of the radio and navigation equipment (at least two views).

4.3.6 Upon approval by PRS the documentation for the equipment's installation in the ship, its installation and activation shall be performed by PRS approved service company. Survey on installation and radio installations operation shall be performed by PRS Surveyor.

4.4 General

4.4.1 Every ship, while at sea, shall comply with the functional requirements (acc. to SOLAS IV/4.1) by being capable:

- .1 except as provided in 4.5.1.1 i 4.7.1.4.3, of transmitting ship-to-shore distress alerts by at least two separate and independent means, each using a different radiocommunication service;
- .2 of receiving shore-to-ship distress alerts;
- .3 of transmitting and receiving ship-to-ship distress alerts;
- .4 of transmitting and receiving search and rescue co-ordinating communications:

- .5 of transmitting and receiving on-scene communications;
 - .6 of transmitting and receiving signals for locating;
 - .7 of transmitting and receiving maritime safety information¹⁾;
 - .8 of transmitting and receiving general radiocommunications to and from shore-based radio system or networks; and
 - .9 of transmitting and receiving bridge-to-bridge communications.
- 4.4.2 Every ship shall be provided with radio installations appropriate for the sea area or areas through which it will pass during its intended voyage, in compliance with the requirements prescribed in 4.5, 4.6, 4.7 or 4.8 (acc. to SOLAS IV/6.1)
- 4.4.3 Every ship shall be provided with (*except of .7 acc. to SOLAS IV/7.1.*):
- .1 **a VHF radio installation capable of transmitting and receiving:**
 - .1.1 DSC on the frequency 156,525 MHz (channel 70). It shall be possible to initiate the transmission of distress alerts from the position from which the ship is normally navigated; and
 - .1.2 radiotelephony on the 156,300 MHz (channel 6), 156,650 MHz (channel 13) and 156,800 MHz (channel 16);
 - .2 a radio installation capable of maintaining a continuous DSC watch on VHF channel 70, which may be separate from, or combined with, that required by 4.4.3.1.1;
 - .3 a radar transponder SART capable of operating in the 9 GHz band, which:
 - .3.1 shall be so stowed that it can be easily used; and
 - .3.2 may be one of transponders required for a survival craft;
 - .4 a receiver capable of receiving international NAVTEX service broadcast if the ship is engaged on voyages in any area in which a service is provided;
 - .5 a radio facility EGC for reception of maritime information by the INMARSAT enhanced group calling system if the ship is engaged on voyages in any area of INMARSAT coverage, but in which an international NAVTEX service is not provided. However, ships engaged exclusively on voyages in areas where an HF direct-printing telegraphy maritime safety information service is provided and fitted with equipment capable of receiving such service, may be exempt from this requirement;
 - .6 subject to the provision of 4.5.3, a satellite emergency position-indicating radio beacon EPIRB which shall be:
 - .6.1 capable of transmitting a distress alert either through the polar orbiting satellite service COSPAS-SARSAT operating in the 406 MHz band or, if the ship is engaged only on voyages within INMARSAT coverage, through the INMARSAT geostationary satellite service operating in 1,6 GHz band²⁾;

¹⁾ It should be noted that ships may have a need for reception of certain maritime safety information while in port.

²⁾ Subject to the availability of appropriate receiving and processing ground facilities for each ocean region covered by INMARSAT satellites. *Należy zwrócić uwagę, że również okręty przebywające w porcie mogą potrzebować odbioru pewnych morskich informacji bezpieczeństwa.????*

- .6.2 installed in an easily accessible position;
- .6.3 ready to be manually released and capable of being carried by one person into a survival craft;
- .6.4 capable of floating free if the ship sinks and of being automatically activated when afloat; and
- .6.5 capable of being activated manually.
- .7 a portable VHF radiotelephone for two-way communication with survival crafts, which shall be so located that can be easily utilized (acc. to *SOLAS III/6.2.1*).

4.5 Radio equipment for sea area A1 (wg *SOLAS IV/8*)

4.5.1 In addition to the requirements of sub-chapter 4.4, every ship engaged exclusively in sea area A1 shall be provided with a radio installation capable of initiating the transmission of ship-to-shore distress alarm from the position from which the ship is normally navigated, operating either:

- .1 on VHF using DSC; this requirement may be fulfilled by the EPIRB prescribed by 4.5.3, either by installing the EPIRB close to, or by remote activation from, the position from which the ship is normally navigated,
- .2 through the polar orbiting satellite service COSPAS-SARSAT, operating on 406 MHz; this requirement may be fulfilled by the EPIRB required by 4.4.3.6, installed close to, or activated from, the position from which the ship is normally navigated; or
- .3 on MF using DSC, if the ship is engaged on voyages within coverage of MF coast stations equipped with DSC, or
- .4 on HF using DSC; or
- .5 through the INMARSAT geostationary satellite service; this requirement may be fulfilled by:
 - .5.1 an INMARSAT ship earth station³, or
 - .5.2 the satellite EPIRB required by 4.4.3.6, installed close to, or by remote activation from, the position from which the ship is normally navigated.

4.5.2 The VHF radio installation, required by 4.4.3.1, shall also be capable of transmitting and receiving general radiocommunications using radiotelephony.

4.5.3 Ships engaged on voyages exclusively in sea area A1 may carry, in lieu of satellite EPIRB required by 4.4.3.6, an EPIRB which shall be:

- .1 capable of transmitting a distress alert using DSC on VHF channel 70 and providing for locating by means of radar transponder SART, operating in the 9 GHz band;
- .2 installed in an easily accessible position;

³ This requirement may be met by INMARSAT ship earth stations capable of two-way communications, such as A, B or C standard stations. Unless otherwise specified, this footnote applies to all requirements for an INMARSAT ship earth station prescribed by this chapter.

- .3 ready to be manually released and capable of being carried by one person into a survival craft;
- .4 capable of floating free if the ship sinks and being automatically activated when afloat; and
- .5 capable of being activated manually.

4.6 Radio equipment for sea areas A1 and A2 (acc. to SOLAS IV/9)

4.6.1 In addition to meeting the requirements of, every ship engaged on voyages beyond sea area A1, but remaining within sea area A2, shall be provided with:

- .1 a MF radio installation capable of transmitting and receiving, for distress and safety purposes, on the frequencies:
 - .1.1 2187,5 kHz using DSC; and
 - .1.2 2182 kHz using radiotelephony;
- .2 a radio installation capable of maintaining a continuous DSC watch on frequency 2187,5 kHz which may be separate from, or combined with the radio installation required by 4.6.1.1.1; and
- .3 means of initiating the transmission of ship-to-shore distress alerts by a radio service other than MF operating either:
 - .3.1 through the polar orbiting satellite service COSPAS-SARSAT, operating on 406 MHz; this requirement may be fulfilled by the EPIRB required by 4.4.3.6, installed close to, or activated from, the position from which the ship is normally navigated; or
 - .3.2 on HF using DSC; or
 - .3.3 through the INMARSAT geostationary satellite service; this requirement may be fulfilled by:
 - an INMARSAT ship earth station, or
 - the satellite EPIRB required by 4.4.3.6, installed close to, or by remote activation from, the position from which the ship is normally navigated.

4.6.2 It shall be possible to initiate transmission of distress alerts by the radio installations specified in 4.6.1.1 i 4.6.1.3 from the position from which the ship is normally navigated.

4.6.3 The ship shall, in addition, be capable of transmitting and receiving general radiocommunications using radiotelephony or narrow band direct-printing (NBDP) telegraphy by either:

- .1 A radio installation operating on working frequencies in the bands between 1605 kHz and 4000 kHz or 4000 kHz and 27 500 kHz. This requirement may be fulfilled by the addition of this capability in the equipment required by paragraph 4.6.1.1; or
- .2 an INMARSAT ship earth station.

4.7 Radio equipment for sea areas A1, A2 and A3 (acc. to SOLAS IV/10)

4.7.1 In addition to meeting the requirements of 4.4, every ship engaged on voyages beyond sea areas A1 i A2, but remaining within sea area A3, shall, if does not comply with the requirements of paragraph 4.7.2, be provided with:

- .1** an INMARSAT ship earth station capable of:
 - .1.1** transmitting and receiving distress and safety communications using narrow band direct-printing (NBDP) telegraphy;
 - .1.2** initiating and receiving distress priority calls;
 - .1.3** maintaining watch for shore-to-ship distress alerts, including those directed to specifically defined geographical areas;
 - .1.4** transmitting and receiving general radiocommunications using radiotelephony or narrow band direct-printing (NBDP) telegraphy;
- .2** a MF radio installation capable of transmitting and receiving, for distress and safety purposes, on the frequencies:
 - .2.1** 2187,5 kHz using DSC; and
 - .2.2** 2182 kHz using radiotelephony; and
- .3** a radio installation capable of maintaining a continuous DSC watch on frequency 2187,5 kHz which may be separate from, or combined with the radio installation required by 4.6.1.1.1; and
- .4** means of initiating the transmission of ship-to-shore distress alerts by a radio service other than MF operating either:
 - .4.1** through the polar orbiting satellite service COSPAS-SARSAT, operating on 406 MHz; this requirement may be fulfilled by the EPIRB required by 4.4.3.6, installed close to, or activated from, the position from which the ship is normally navigated; or
 - .4.2** on HF using DSC; or
 - .4.3** through the INMARSAT geostationary satellite service, by an additional INMARSAT ship earth station or by the satellite EPIRB required by 4.4.3.6, installed close to, or by remote activation from, the position from which the ship is normally navigated.

4.7.2 In addition to meeting the requirements of 4.4, every ship engaged on voyages beyond sea areas A1 i A2, but remaining within sea area A3, shall, if does not comply with the requirements of paragraph 4.7.1, be provided with:

- .1** an MF/HF radio installation capable of transmitting and receiving, for distress and safety purposes, on all distress and safety frequencies in the bands between 1605 kHz and 4000 kHz, and between 4000 kHz and 27 500 kHz:
 - .1.1** using DSC;
 - .1.2** using radiotelephony; and
 - .1.3** using narrow band direct-printing telegraphy; and
- .2** equipment capable of maintaining a continuous DSC watch on frequency 2187,5 kHz, 8414,5 kHz and on at least one of the distress and safety DSC: 4207,5 kHz, 6312 kHz, 12 577 kHz or 16804,5 kHz. It shall be possible

to select, at any time, any of these DSC distress and safety frequencies. This equipment may be separate from, or combined with, the equipment required by 4.7.2.1; and

- .3 means of initiating the transmission of ship-to-shore distress alerts by a radio service other than HF operating either:
 - .3.1 through the polar orbiting satellite service COSPAS-SARSAT, operating on 406 MHz; this requirement may be fulfilled by the EPIRB required by 4.4.3.6, installed close to, or activated from, the position from which the ship is normally navigated; or
 - .3.2 through the INMARSAT geostationary satellite service; this requirement may be fulfilled by:
 - an INMARSAT ship earth station, or
 - the satellite EPIRB required by 4.4.3.6, installed close to, or by remote activation from, the position from which the ship is normally navigated; and
- .4 in addition, ships shall be capable of transmitting and receiving general radiocommunications using radiotelephony or narrow band direct-printing, NBDP, telegraphy, by an MF/HF radio installation operating on working frequencies in the bands between 1605 kHz and 4000 kHz and between 4000 kHz and 27 500 kHz. This requirement may be fulfilled by addition of this capability in the equipment required by 4.7.2.1.

4.7.3 It shall be possible to initiate transmission of distress alerts by the radio installations specified in paragraphs 4.7.1.1, 4.7.1.2, 4.7.1.4, 4.7.2.1 and 4.7.2.3 from the position from which the ship is normally navigated.

4.8 Radio equipment for sea areas A1, A2, A3 and A4 (*acc. to SOLAS IV/11*)

4.8.1 In addition to meeting the requirements of 4.4, every ship engaged on voyages in all sea areas shall be provided with the radio installations and equipment required by 4.7.2, except that the equipment required by shall not be accepted as an alternative to that required by 4.7.2.3.1, which shall always be provided. In addition, ships engaged on voyages in all sea areas shall comply with the requirements of paragraph 4.7.3.

4.9 Sources of energy (*acc. to SOLAS IV/13, except of 4.9.1, 4.9.2, 4.9.3*)

4.9.1 All radio installations indicated in the sub-chapter 4.2 shall be supplied from separate circuits of a radio installations switchboard.

4.9.2 The radio installations switchboard shall be supplied by independent circuits from the main and an emergency source of power supply in accordance with the requirements of *SOLAS 74 Convention*, Chapter II, with amendments 1997, as well as the requirements of the *Part VIII – Electrical installations and control systems*. Cables of these circuits shall be led in different routes, as practicable far away of each other – both, vertically and horizontally. Possibility of prompt switch-over of the sources of electrical power supply shall be provided.

4.9.3 In the case of ships constructed before 01.02.1995 r. supply of radio installations with one circuit, supplied by the main and emergency source of power, is permitted.

4.9.4 A reserve source or sources of energy shall be provided on every ship, to supply radio installations, for the purpose of conducting distress and safety radiocommunications, in the event of failure of the ship's main and emergency sources of electrical power. The reserve source or sources of energy shall be capable of simultaneously operating the VHF radio installations required by 4.4.3.1 and, as appropriate for the sea area or sea areas for which the ship is equipped, either MF radio installation required by 4.6.1.1 or MF/HF radio installation required by 4.7.2.1 or 4.8.1, or the INMARSAT ship earth station required by 4.7.1.1, and any of the additional loads mentioned in 4.9.6, 4.9.7 and 4.9.9 for a period of at least:

- .1 1 hour on ships provided with an emergency source of electrical power, if such source of power complies fully with all relevant provisions of regulation II-1/42 or 43 SOLAS 74/97 Convention and with Part VIII – Electrical installations and control systems; and
- .2 6 hours on ships not provided with an emergency source of electrical power complying fully with all relevant provisions of regulation II-1/42 or 43 SOLAS 74/97 Convention and with Part VIII – Electrical installations and control systems¹⁾.

The reserve source or sources of energy need not supply independent HF and MF radio installations at the same time.

4.9.5 The reserve source or sources of energy shall be independent of the propelling power of the ship and the ship's electrical system.

4.9.6 Where, in addition to the VHF radio installation, two or more of the other radio installations, referred to in 4.9.4, can be connected to the reserve source or sources of energy, they shall be capable of simultaneously supplying, for the period specified, as appropriate, in 4.9.4.1 or 4.9.4.2, the VHF radio installation, and:

- .1 all other radio installations which can be connected to the reserve source or sources of energy at the same time; or
- .2 whichever of the other radio installations will consume the most power, if only one of the radio installations can be connected to the reserve source or sources of energy at the same time as the VHF radio installation.

4.9.7 The reserve source or sources of energy may be used to supply the electric lighting required by 4.11.1.1.

¹⁾ For guidance, the following formula is recommended for determining the electrical load to be supplied by the reserve source of energy for each radio installation required for distress conditions: $\frac{1}{2}$ of the current consumption necessary for transmission + the current consumption necessary for reception + the current consumption for any additional loads.

4.9.8 Where a reserve source of energy consists of a rechargeable accumulator battery or batteries, then:

- .1 a means of automatically charging such batteries shall be provided which shall be capable of recharging them to minimum capacity requirements within 10 hours; and
- .2 when the ship is not at sea, the capacity of the battery or batteries shall be checked, using an appropriate method¹⁾, at intervals not exceeding 12 months.

4.9.9 A GPS receiver utilized for the purpose of automatic ship's position data transmitting to the shipborne radio installations shall be additionally supplied from the reserve accumulator batteries, or by uninterrupted power supply (UPS). An automatic switch-over to supply from the reserve accumulator battery shall be provided.

4.10 Installation requirements

4.10.1 Arrangement

4.10.1.1 Radio equipment should be installed in the wheelhouse in such a way that the operating person's face was turned in the direction of the ship motion, and was provided with good visibility in this direction. In the vicinity of the radio equipment, the clock shall be installed.

4.10.1.2 Radio equipment can be mounted on a table or wall. It can be installed separately or as complex GMDSS radio station console. Among the documents which, according to Annex AP-11 of the *Radio Regulations* should be carried on board the ship, in the vicinity of the installation of radio equipment, following should be stored:

- .1 instruction manual for each device;
- .2 where "at-sea" maintenance is declared, maintenance instructions for all equipment;
- .3 list of call signs and digital identity codes of maritime mobile stations and maritime-satellite mobile services;
- .4 list of the shore-based stations and coastal earth GMDSS stations transmitting general correspondence and MSI;
- .5 list of ship stations;
- .6 the maritime mobile services and the maritime-satellite mobile services manuals.

¹⁾ One method of checking the capacity of an accumulator battery is their complete discharge and recharge, using normal operating current and period (e.g. 10 hours). Assessment of the charge condition can be made at any time, but it should be done without significant discharge of the battery when the ship is at sea.

4.10.1.3 Every radio installation shall: (*acc. to SOLAS IV/6.2*):

- .1 be so located that no harmful interference of mechanical, electrical or other origin affects its proper use, and so as to ensure electromagnetic compatibility and avoidance of harmful interaction with other equipment and systems;
- .2 be so located as to ensure the greatest possible degree of safety and operational availability;
- .3 be protected against harmful effects of water, extremes of temperature or other adverse environmental conditions.

VHF/DSC radio installation shall be located in the vicinity of the main radar (the position on navigation and manoeuvring)¹⁾, in the place convenient for commanding the ship, and be so installed, that easy access is ensured, and the face of the operator is turned towards the ship motion. In the immediate vicinity of the installation the plate with the ship's call sign and the maritime mobile service MMS ID shall be placed.

Where necessary, facilities should be available to permit radiocommunications from the wings of the navigation bridge. Portable VHF equipment may be used to meet the latter provision. (*acc. to SOLAS IV/6.3*).

4.10.1.4 Float-free emergency satellite EPIRB should be mounted on the open deck in such a way, that its shifting in extreme conditions would take place, and it remains afloat in the case of the ship's sinking.

4.10.1.5 Radar transponders SART, survival crafts' two-way portable VHF radiotelephones and emergency EPIRBs, if provided, shall be stored in a wheelhouse or in other, not locked during the voyage, compartment in a manner enabling their prompt and easy transfer to any lifeboat or liferaft.

4.10.1.6 The siting and installation of accumulator batteries which provide a reserve source of energy shall be such as to ensure (*acc. to SOLAS IV/13.7*):

- .1 the highest degree of service;
- .2 a reasonable lifetime;
- .3 a high degree of safety;
- .4 that battery temperatures remain within the manufacturer's specifications whether under charge or idle; and
- .5 that when fully charged, the batteries will provide at least the minimum required hours of operation under all weather conditions.

4.10.1.7 Accumulator batteries shall be installed in the possibly closest vicinity of the radio installations.

¹⁾ See chapter 5.

4.10.1.8 In order to maintain, during operation, the battery required minimum capacity, the batteries should be installed in an enclosed battery room with adequate ventilation and temperature which falls in the range of +15 ° C to +35 ° C. Batteries provided for the outside installation should be able to withstand changes in temperature range from -20 ° C to +55 ° C.

4.10.1.9 Electrical equipment and devices for charging, placed in the batteries room, should be sparking-safe. Batteries should be so arranged, that between them appropriate distances, allowing the inspection and maintenance, are maintained.

4.10.1.10 Radio accumulators compartments shall comply with the requirements of chapter II *SOLAS 74/97Convention*, as well as the requirements of *Part VIII – Electrical installations and control systems*.

4.10.2 Cable network installation

4.10.2.1 Installation of cable network and protection measures for radio reception against interference caused by the ship's electrical equipment should be made in accordance with the requirements of chapter II *SOLAS 74/97Convention*, as well as the requirements of *Part VIII – Electrical installations and control systems*.

4.10.2.2 The entire cable network for marine radio equipment shall be installed with the use of screened cables with shielding continuity. Where the cables are led to the compartments in which the receivers are installed, their screens shall be earthed.

4.10.2.3 The antenna circuit cables shall be led separately from the cables of other application. If the latter is not practicable, double-screen cables shall be applied.

4.10.2.4 Internal bending radii of big diameter special and concentric cables shall not be less than those required by the manufacturer.

4.10.2.5 The insulation resistance of any installed cable, disconnected on both sides from the radio equipment, shall be at least 20 MΩ, irrespective of its length.

4.10.2.6 The insulation resistance to hull of the antennas shall, at normal climatic conditions, be at least 10 MΩ, and at high humidity – at least 1 MΩ.

4.10.3 Earthing

4.10.3.1 Radio installations shall be provided with the protective and operational high frequency earthing, led by the shortest route, in compliance with the requirements of chapter II *SOLAS 74/97Convention*, as well as the requirements of *Part VIII – Electrical installations and control systems*.

4.10.3.2 The operational high frequency earthing shall be made of a copper strap, led by the shortest route from the transmitter/transmitting antennae switch/antennae coupler to the metal bulkhead or deck having reliable electrical connection with the

hull of the ship, with the grounding terminals of these transmitters— in compliance with the requirements of chapter II *SOLAS 74/97 Convention*, as well as the requirements of *Part VIII – Electrical installations and control systems*. Length of the strap from the transmitter to the place of connection with the bulkhead or deck shall not exceed 1500 mm. Depending on the transmitter power straps and leads cross-sections should be not less than:

- .1 25 mm² for the transmitter of the power less than 50 W;
- .2 50 mm² for the transmitter of the power within 50 and 500 W;
- .3 100 mm² for the transmitter of the power greater than 500 W.

4.10.3.3 In all cases, where applicable, working earthing of each transmitter may be provided separately by connecting earthing terminals of transmitter with the closest metal bulkhead by means of a copper strap or flexible conductor of adequate cross-section.

4.10.3.4 In transmitters of the power greater than 50 W electrical connection of an earthing strap (flexible conductor) with the transmitter case shall be provided in at least two, the most remote from each other, places.

4.10.3.5 Working earthing of receivers shall be provided by means of copper strap or flexible copper wire of a cross-section at least 6 mm², led by the shortest route from each receiver to the main earthing strap, or directly to the nearest bulkhead connected with the ship's hull.

4.10.3.6 Metal casings of the radio equipment shall be electrically connected by the shortest route with the ship's hull. While leading the cables into the apparatus, their screening shields shall be electrically connected with the apparatus casing.

4.10.3.7 Connecting conductors of the radio equipment casings protective earthing should be as short as possible, and not longer than 150 mm.

4.10.3.8 Earthing of the standing rigging of masts and smoke stacks' lower ends should be made by the main wire strand or by the flexible metal conductors.

4.10.3.9 The general resistance of all electrical connections of any earthing shall not exceed 0,02 Ω.

4.10.3.10 Places of the equipment earthing to the hull shall be accessible for periodical measurements and maintenance.

4.10.3.11 Application of the radio equipment antennas as lightning arresters is forbidden.

4.10.4 Antennas

4.10.4.1 Radio equipment antennae shall be installed in accordance with their manufacturers guidelines, including the requirements of the present chapter 4.

4.10.4.2 Receiving antennae should be so designed and arranged that interaction between them, as well as with all broadcasting antennas, is minimal.

4.10.4.3 Antennae wires and their conductors shall not be closer than 1 m from funnels, masts and other metal parts of the ship. Antennae shall be placed in such a manner that they do not touch ship's metal structure in all operating conditions.

4.10.4.4 Separate elements of the masthead antennae, such as wires, rods and insulators, shall be easy changeable. It is recommended that the masthead antennas design allows their laying down.

4.10.4.5 In ships for the transport of liquid fuels and other flammable cargoes, in masts' steel rigging (shrouds, stays, ship's whistle wire, cargo shrouds) insulators shall be inserted. Insulators shall be inserted in such a way that the distance between them is not more than 6 m, and the distance from the deck to the lower insulator – not less 3 m and no more than 4 m. In order to reduce losses at transmitters work it is recommended to share rigging by means of insulators on all ships. Sharing of cargo shrouds by insulators is mandatory for all ships.

4.10.4.6 The standing rigging of masts and smoke stacks' lower ends shall be electrically connected with the ship's hull. All other rigging shall be insulated from the ship's hull or, where not practicable, reliably electrically connected to the hull with a bronze or steel wire.

4.10.4.7 Antennae of radio and TV receivers shall be the most distant from all antennas designated for service application.

4.10.4.8 Antennae inlets shall be installed in locations ensuring leading the antennas wire inside a compartment by the shortest run to the transmitters. If the antenna coupler and / or transmitting antenna cord are placed in an easily accessible place, it should be completely separated to prevent their accidental touch from the within 1800 mm above the relevant deck, gangway or other place where people may pass. When installing stanchions or hollowed antennas' masts, possibility for drainage of condensed inside water shall be provided.

4.10.4.9 In order to avoid the power loss it is recommended that fences made of insulating materials are applied. In the case of metal fences, they should be reliably grounded to the hull of the ship. The fence should be installed, wherever possible, in such a place, that it does not create any dead angle in the optical bearing.

4.10.4.10 Antennas' run shall be made of high-frequency screened cables with shielding continuity. Antenna switches, lightning arresters and other devices connected to these type of cables shall be screened. Leads shall not introduce signal suppression greater than 3 dB.

4.10.4.11 Screened high-frequency cables of receiving antennas shall be led directly to the open deck and connected at a sufficient height to the receiving antennas by means of special transient devices of a hose-proof or hermetic structure, providing sufficient electrical connection and access to monitor their condition.

4.10.4.12 For each antenna not provided for a permanent connection to the working position, inside the compartment switching device, that allows setting it in a working position, insulated and grounded, shall be provided.

4.10.4.13 To protect receiver input against atmospheric discharges in each of the receiving antenna adequate device shall be provided. In the case of application of the matching system between the receiving antenna and high frequency cable, protection equipment against lightning shall be installed before the entry into the matching device (from the antenna side).

4.10.4.14 VHF antenna should be placed as high as possible (where conditions allow, at least 9.15 m above the deepest waterline) and in such a way that on the way of the electromagnetic waves propagation, as far as practicable, around the all horizon there were no obstacles.

4.10.4.15 VHF antennas should be placed at a distance greater than 1 m from the parallel conductive structures.

4.10.4.16 If the VHF radio antenna is placed at the same height as the watch VHF / DSC receiver antenna, the distance between them should be at least 5 m.

4.10.4.17 Where an omnidirectional antenna is used it should, if practicable, be sited in such a position that no obstacle likely to degrade significantly the performance of the equipment appears in the fore and aft directions down to -5° and in the port and starboard directions down to -15° . For omnidirectional antennas, objects, especially those within 1 m of the antenna, which cause a shadow sector of greater than 2° , are likely to degrade significantly the performance of the equipment. (*acc. to Res. A.807(19)*).

4.10.4.18 Where a stabilized directive antenna is used it should, if practicable, be sited in such a position that no obstacle likely to degrade significantly the performance of the equipment appears in any azimuth down to -5° . For directive antennas with a gain of approximately 20 dB, objects, especially those within 10 m of the antenna, which cause a shadow sector of greater than 6° , are likely to degrade significantly the performance of the equipment. (*acc. to Res. A.807(19)*).

4.10.4.19 In order to permit a warning of potential radiation hazards to be displayed in appropriate locations, a label should be attached to the radome indicating the distances external to the radome at which radiation levels of 100 W/m^2 , 25 W/m^2 and 10 W/m^2 exist. (*acc. to Res. A.807(19) and Res. A.808(19)*).

4.10.4.20 The height of the installed SART antenna should be at least 1 m above sea-level (*Res. A.802(19)*).

4.11 Performance requirements for radio installations

4.11.1 General (acc. to Res. A.694(17))

4.11.1.1 Every radio installation shall be:

- .1** be provided with reliable, permanently arranged electrical lighting for the adequate illumination of the radio controls, independent from the main and emergency sources of electrical energy; means should be provided for dimming the illumination;
- .2** be clearly marked with the call sign, the ship station identity and other codes as applicable for use of the radio station;
- .3** equipped with controls, which number, their design and manner of function, location, arrangement, size and easy availability shall provide for simple, quick and effective operation;
- .4** so designed that misuse of the controls shall not cause damage to the equipment or injury to personnel; controls not required for normal operation shall not be readily accessible.

4.11.1.2 If a unit of equipment is connected to one or more other units of equipment the performance of each should be maintained.

4.11.1.3 Where a digital input panel with the digits 0 to 9 is provided, the digits should be arranged to conform with relevant *CCITT E161/QII* recommendations. However, where an alphanumeric keyboard layout, as used on office machinery and data processing equipment, is provided, the digits 0 to 9 may, alternatively, be arranged to conform with the ISO 3791 standard.

4.11.1.4 The presence of variations of power supply normally to be expected in a ship shall not interfere proper operation of the equipment.

4.11.1.5 Means shall be incorporated for the protection of equipment from the effects of excessive current and voltage, transients and accidental reversal of the power supply polarity.

4.11.1.6 If provision is made for operating equipment from more than one source of electrical energy, arrangements for rapidly changing from one source to the other shall be provided, but not necessarily incorporated in the equipment

4.11.1.7 Equipment shall be capable of continuous operation under the various conditions of the ship operation, and shall pass mechanical and environmental tests in accordance to the requirements of the *IEC Publication 945*.

4.11.1.8 Electromagnetic compatibility between the equipment concerned and other radiocommunication and navigational equipment carried on board shall be ensured.

4.11.1.9 Each unit of equipment normally to be installed in the vicinity of a standard compass or a magnetic steering compass should be clearly marked with the minimum safe distance at which it may be mounted from such compasses.

4.11.1.10 Mechanical noise from all units shall be limited so as not to prejudice the hearing of sounds on which the safety of the ship might depend.

4.11.1.11 The design of the radio equipment shall be such that accidental access to parts of the equipment under voltages greater than 55 V is prevented. Access to such voltages may only be gained after having used a tool for this purpose. Warning labels should be prominently displayed both within the equipment and on protective covers.

4.11.1.12 Means should be provided for earthing exposed metallic parts of the equipment but this should not cause any terminal of the source of electrical energy to be earthed.

4.11.1.13 All steps should be taken to ensure that electromagnetic radio frequency energy radiated from the equipment shall not be a hazard to personnel.

4.11.1.14 Equipment containing elements such as vacuum tubes which are likely to cause X-radiation should comply with the following requirement:

- .1** external X-radiation from the equipment in its normal working condition shall not exceed the limits laid down by the Administration concerned;
- .2** when X-radiation can be generated inside the equipment above the levels laid down by the Administration, a prominent warning shall be fixed inside the equipment and the precautions to be taken when working on the equipment should be included in the equipment manual.

4.11.1.15 If malfunction of any part of the equipment can cause an increase in X-radiation, adequate advice should be included in the information about the equipment, warning of the circumstances which could cause the increase and stating the precautions which should be taken.

4.11.1.16 The equipment should be so designed that the main units can be replaced readily, without elaborate recalibration or readjustment. Equipment should be so constructed and installed that it is readily accessible for inspection and maintenance purposes.

4.11.1.17 Adequate information should be provided to enable the equipment to be properly operated and maintained. The information should;

- .1** in the case of equipment so designed that fault diagnosis and repair down to component level are practicable, provide full circuit diagrams, component layouts and a component parts list; and
- .2** in the case of equipment containing complex modules in which fault diagnosis and repair down to component level are not practicable, contain sufficient information to enable a defective complex module to be located, identified and replaced.

4.11.1.18 Each unit of the equipment should be marked externally with the following information which should be clearly visible in the normal installation position:

- .1 identification of the manufacturer;
- .2 equipment type number or model identification under which it was type tested;
- .3 serial number of the unit.

4.11.2 VHF radio installations for voice and digital selective calling DSC
(*acc. to Res.A.803(19) and MSC.68(68)*), excluding 4.11.2.31)

4.11.2.1 The VHF installation, which may consist of more than one piece of equipment, should be capable of operating on single-frequency channels or on single- and two-frequency channels.

4.11.2.2 The VHF equipment should provide for the following categories of calls using both voice and digital selective calling (DSC):

- .1 distress, urgency and safety;
- .2 ship operational requirements; and
- .3 public correspondence.

4.11.2.3 The VHF equipment should provide for the following categories of communications using voice:

- .1 distress, urgency and safety
- .2 ship operational requirements; and
- .3 public correspondence.

4.11.2.4 The VHF equipment should comprise at least:

- .1 a transmitter/receiver including antenna;
- .2 an integral control unit or one or more separate control units;
- .3 a microphone with a press-to-transmit switch, which may be combined with a telephone in a handset;
- .4 an internal or external loudspeaker;
- .5 an integral or separate digital selective calling DSC facility; and
- .6 a dedicated DSC watchkeeping facility to maintain a continuous watch on channel 70.

4.11.2.5 The VHF installation may also include additional receivers.

4.11.2.6 A distress alert should be activated only by means of a dedicated distress button. The dedicated distress button should be clearly identified and protected against inadvertent operation. The distress alert initiation should require at least two independent actions. It should be possible to interrupt and initiate distress alerts at any time.

4.11.2.7 The VHF equipment should indicate the status of the distress alert transmission.

4.11.2.8 The VHF radiotelephone facility should be capable of operating on emission specified in Appendix 19 of the Radio Regulations as follows:

- .1** in the band 156.3 MHz to 156.875 MHz on single-frequency channels as specified in Appendix 18 to the Radio Regulations; and;
- .2** in the band 156.025 MHz to 157.425 MHz for transmitting and the band 160.625 MHz to 162.025 MHz for receiving on two-frequency channels as specified in Appendix 18 to the Radio Regulations.

4.11.2.9 The VHF installation shall be provided with the sufficient number of channels, but not less than 3, including channel 16 (156,800 MHz) for distress communications, channel 6 (156,300 MHz) for SAR communications, and channel 13 (156,650 MHz) for ship-to-ship communications (*acc. to SOLAS IV/7.1.1*).

4.11.2.10 Maximum frequency deviation, corresponding to 100% modulation depth, shall be possibly close to 5 kHz, but in no case exceed +/- 5 kHz.

4.11.2.11 Preemphasis and deemphasis shall be 6 dB per octave.

4.11.2.12 The band of acoustic frequencies transmission shall not exceed 3000 Hz.

4.11.2.13 The digital selective calling facility should be capable of operating on channel 70 using emission G2B.

4.11.2.14 Change of channel should be capable of being made as rapidly as possible, but in any event within 5 s. The time taken to switch from the transmit to the receive condition, and vice versa, should not exceed 0.3 s.

4.11.2.15 An on/off switch should be provided for the entire installation with a visual indication that the installation is switched on. A visual indication that the carrier is being transmitted should be provided.

4.11.2.16 The VHF equipment should indicate the channel number, as given in the Radio Regulations, to which it is tuned. It should allow the determination of the channel number under all conditions of external lighting. Channels 16 and 70 should be distinctively marked.

4.11.2.17 Control of the VHF equipment should be possible at the position from which the ship is normally navigated. Control from that position should have priority if additional control units are provided. When there is more than one control unit, indication should be given to the other units that the equipment is in operation.

4.11.2.18 The VHF equipment should not be able to transmit during a channel switching operation. Operation of the transmit/receive control should not cause unwanted emissions.

4.11.2.19 Provision should be made for changing from transmission to reception by use of a press-to-transmit switch. Additionally, facilities for operation on two-frequency channels without manual control may be provided.

4.11.2.20 The VHF receiver should be provided with a manual volume control by which the audio output may be varied.

4.11.2.21 A squelch (mute) control should be provided on the exterior of the equipment.

4.11.2.22 The VHF equipment should be operational within 1 min of switching on. The equipment, when operating, should not be damaged by the effects of open-circuited or short-circuited antenna terminals.

4.11.2.23 The transmitter output power should be between 6 and 25 W. Provision should be made for reducing the transmitter output power to a value of between 0.1 and 1 W. However, this reduction of the power is optional on channel 70 with exemption of distress calling.

4.11.2.24 The sensitivity of the receiver should be equal to or better than $1\mu\text{V}$ e.m.f. for a signal-to-noise ratio of 20 dB.

4.11.2.25 With a DSC modulated input signal having a level of $1\mu\text{V}$ e.m.f. to its associated VHF receiver, the DSC equipment should be capable of decoding the received message with a maximum permissible output character error rate of 10^{-2} .

4.11.2.26 The immunity to interference of the receiver should be such that the wanted signal is not seriously affected by unwanted signals.

4.11.2.27 The VHF antenna or antennae should be vertically polarized and, as far as practicable, be omnidirectional in the horizontal plane. The installation should be suitable for efficient radiation and reception of signals at the operating frequencies.

4.11.2.28 The receiver output should be suitable for use with a loudspeaker or a telephone handset. The audio output should be sufficient to be heard in the ambient noise level likely to be encountered on board ships. It should be possible to switch off the loudspeaker without affecting the audio output of the telephone handset.

4.11.2.29 In the transmit condition during simplex operation, the output of the receiver should be muted. In the transmit condition during duplex operation a loudspeaker should be switched-off automatically.

4.11.2.30 The DSC facility should be of class A or B¹⁾.

4.11.2.31 The DSC facility should comprise:

- .1 means to decode and encode DSC messages;
- .2 means necessary for composing the DSC message;
- .3 means to verify the prepared message before it is transmitted;
- .4 means to display the information contained in a received call in plain language;
- .5 means for the manual entry of the position and time information and, additionally, automatic entry shall be provided (acc. to Res. MSC 68(68)); and
- .6 facilities to automatically update the ship's position and the time at which the position was determined from a suitable electronic position-fixing aid which may be an integral part of the equipment. For equipment which does not have an integral position-fixing aid, such facilities should include a suitable interface conforming to the IEC 1162 Publication⁴ (acc. to Res. MSC 68(68));
- .7 means to activate an alarm when no position data is received from the electronic position-fixing aid or, in the case of manual input, the position information is over 4 hours old. Any position information not updated for more than 23,4 hours should be erased. (acc. to Res. MSC 68(68)).

4.11.2.32 If the received messages are not printed immediately, sufficient capacity should be provided to enable at least 20 received distress messages to be stored in the DSC facility. These messages should be stored until readout.

4.11.2.33 These messages should be stored until readout and should be erased 48 hours after their reception. (acc. to Res. MSC 68(68)).

4.11.2.34 Initiation of DSC distress calls should supersede any other operation of the facility.

4.11.2.35 Self-identification data should be stored in the DSC unit. It should not be possible for the user easily to change these data.

4.11.2.36 Means should be provided to enable routine testing of the DSC facilities without radiation of signals.

¹⁾ Definitions of DSC classes and relevant requirements are contained in ITU-R M.493 Recommendation.

⁴ Applicable to the equipment installed on board from 01 January 2000.

4.11.2.37 DSC facility shall be provided with a specific aural alarm and visual indication to indicate receipt of a distress or urgency call or a call having distress category. It should not be possible to disable this alarm and indication. Provision should be made to ensure that they can be reset only manually.

4.11.2.38 DSC facility shall be provided with an aural alarms and visual indication for calls other than distress and urgency.

4.11.3 MF radio installations for voice communication and digital selective calling DSC (*acc. to Res. A.804(19) and MSC.68(68)*)

4.11.3.1 The MF installation, which may consist of more than one piece of equipment, should be capable of operating on single-frequency channels or on single- and two-frequency channels.

4.11.3.2 The MF equipment should provide for the following categories of calling, using both voice and digital selective calling (DSC):

- .1 distress, urgency and safety;
- .2 ship operational requirements; and
- .3 public correspondence.

4.11.3.3 The equipment should provide for the following categories of communications, using voice and, optionally, narrow-band direct printing (NBDP):

- .1 distress, urgency and safety;
- .2 ship operational requirements; and
- .3 public correspondence.

4.11.3.4 The MF equipment should comprise at least:

- .1 a transmitter/receiver, including antenna;
- .2 an integral control unit or one or more separate control units;
- .3 a microphone with a press-to-transmit switch, which may be combined with a telephone in a handset;
- .4 an internal or external loudspeaker;
- .5 an integral or separate digital selective calling facility DSC; and;
- .6 a dedicated DSC watchkeeping facility to maintain a continuous watch on the distress channel 2187,5 kHz.

4.11.3.5 A distress alert should be activated only by means of a dedicated distress button. The dedicated distress button should be clearly identified and protected against inadvertent operation. The distress alert initiation should require at least two independent actions. The equipment should indicate the status of the distress alert transmission.

4.11.3.6 It should be possible to interrupt and initiate distress alerts at any time.

4.11.3.7 The radiotelephone and DSC transmitter should be capable of transmitting on a number of frequencies in the bands between 1,605 kHz and 4,000 kHz, but at least on the frequencies 2,182 kHz and 2,187.5 kHz.

4.11.3.8 Radiotelephone frequencies are designated in terms of the carrier frequency. DSC frequencies are designated in terms of the assigned (centre) frequency. When DSC signals are transmitted using a transmitter in J2B mode, the (suppressed) carrier frequency should be adjusted so as to have the DSC signal transmitted on the assigned DSC frequency. The selected transmitter frequency should be clearly identifiable on the control panel of the equipment.

4.11.3.9 The transmitter should be capable of transmitting (upper side band signals, where appropriate) using classes of emission J3E, H3E and either J2B or F1B.

4.11.3.10 When switching to the preset distress frequency 2,182 kHz, the appropriate class of emission in accordance with the *Radio Regulations* should be selected automatically.

4.11.3.11 When switching to the preset distress frequency 2,187.5 kHz, the class of emission J2B or F1B should be selected automatically.

4.11.3.12 It should be possible to change the transmitter from any class of emission to another for which it is designed to operate by means of not more than one control.

4.11.3.13 It should be possible for the user to select transmission frequencies independent of any receiver setting. This does not preclude the use of transceivers.

4.11.3.14 It should be possible to change the transmitter quickly from operation on any frequency to operation on any other frequency, and in any event within a period not exceeding 15 s. The equipment should not be able to transmit during channel switching operations.

4.11.3.15 Means should be provided to prevent over-modulation automatically.

4.11.3.16 The transmitter frequency should remain within 10 Hz of the required frequency at all times following the warming-up period.

4.11.3.17 During normal modulation, the peak envelope power in the case of J3E or H3E emissions, or the mean power in the case of J2B or F1B emissions, should be at least 60 W at any frequency within the specified frequency range.

4.11.3.18 If the rated output power exceeds 400 W, provision should be made for reducing the output to 400 W or less.

4.11.3.19 The equipment should be capable of operating on 2,182 kHz and 2,187.5 kHz within 1 min after switching on.

4.11.3.20 Continuous operation should be possible when the transmitter is adjusted to its rated power.

4.11.3.21 Provision should be made for indicating the antenna current or power delivered to the antenna. Failure of the indicating system should not interrupt the antenna circuit.

4.11.3.22 Manually tuned equipment should be fitted with a sufficient number of indicators to permit accurate and rapid tuning.

4.11.3.23 Operation of the transmit/receive control should not cause unwanted emissions.

4.11.3.24 All adjustments and controls necessary for switching the transmitter to operate on 2,182 kHz and 2,187.5 kHz should be clearly marked, in order that these operations may be performed readily.

4.11.3.25 The equipment should be so designed and constructed that, when the transmitter is providing power to the antenna, the transmitter is protected against damage resulting from disconnection of the antenna or short-circuiting of antenna terminals. If this protection is provided by means of a safety device, that device should automatically be reset following removal of the antenna open-circuit or short-circuit conditions.

4.11.3.26 If it is necessary to delay the application of voltage, for example anode voltage, to any part of the transmitter after switching on, this delay should be provided automatically.

4.11.3.27 If the transmitter includes parts which are required to be heated in order to operate correctly, for example crystal ovens, the power supplies to the heating circuits should be so arranged that they can remain operative when other supplies to or within the equipment are switched off. If a special switch for the heating circuits is provided, its function should be clearly indicated; it shall normally be in the "on" position and be protected against inadvertent operation. The correct operating temperature should be reached within a period of 30 min after the application of power.

4.11.3.28 The receiver should be capable of being tuned throughout the bands between 1,605 kHz and 4,000 kHz. Tuning should be either continuous, or by incremental steps, or by the selection of a number of spot frequencies considered by the Administration as adequate for the operation of the ship, or by any combination of these methods. The frequencies 2,182 kHz and 2,187.5 kHz should always be promptly tunable.

4.11.3.29 Radiotelephone frequencies should be designated in terms of the carrier frequency; DSC frequencies should be designated in terms of assigned (centre) frequency. The selected receiver frequency should be clearly identifiable on the control panel of the equipment.

4.11.3.30 The receiver should be capable of receiving upper side band signals, as appropriate, for classes of emission J3E, H3E, J2B and F1B. The class of emission should be selectable by not more than one control.

4.11.3.31 It should be possible for the user to select reception frequencies independent of any transmitter setting. This does not preclude the use of transceivers.

4.11.3.32 The receiver should be capable of being tuned to different frequencies quickly, and in any event, within a period not exceeding 15 s.

4.11.3.33 The receiver frequency should at all times remain within 10 Hz of the required frequency following the warming-up period.

4.11.3.34 For classes of emission J3E and F1B the sensitivity of the receiver should be equal to or better than 6 μ V e.m.f at the receiver input for a signal-to-noise ratio of 20 dB. For DSC, an output character error rate of 0,01 or less should be obtained for a signal-to-noise ratio of 12 dB..

4.11.3.35 For the reception of voice signals, the receiver should be suitable for use with a loudspeaker and a telephone handset and should be capable of providing power of at least 2 W to the loudspeaker and at least 1 mW to the handset.

4.11.3.36 An output should be provided for DSC signals if the corresponding facility is not integrated.

4.11.3.37 The receiver should be capable of operating on 2,182 kHz and 2,187.5 kHz within 1 min after switching on.

4.11.3.38 The immunity to interference of the receiver should be such that the wanted signal is not seriously affected by unwanted signals.

4.11.3.39 All adjustment and controls necessary for switching the receiver to operate on 2,187.5 kHz should be clearly marked in order that these operations may be performed readily.

4.11.3.40 The receiver should be provided with automatic gain control.

4.11.3.41 A DSC facility should be of class A or B¹⁾.

4.11.3.42 The DSC facility should comprise:

- .1 means to decode and encode DSC messages;
- .2 means necessary for composing the DSC message;
- .3 means to verify the prepared message before it is transmitted;
- .4 means to display the information contained in a received call in plain language;
- .5 means for manual entry of position information and the time at which the position was determined and, additionally, possibility of automatic entry of these data; (*acc. to Res. MSC 68(68)*)
- .6 means to display, in plain language with a minimum of 160 characters in two or more lines, the information contained in a received call; (*acc. to Res. MSC 68(68)*);

¹⁾ Definitions of DSC classes and relevant requirements are contained in ITU-R M.493 Recommendation.

- .7 facilities to automatically update the ship's position and the time at which the position was determined from a suitable electronic position-fixing aid which may be an integral part of the equipment. For equipment which does not have an integral position-fixing aid, such facilities should include a suitable interface conforming to the IEC Publication 1162 (*acc. to Res. MSC 68(68)*);
- .8 means to activate an alarm when no position data is received from the electronic position-fixing aid or, in the case of manual input, the position information is over 4 hours old. Any position information not updated for more than 23,5 hours should be erased (*acc. to Res. MSC 68(68)*).

4.11.3.43 If the received messages are not printed immediately, sufficient capacity should be provided to enable at least 20 received distress messages to be stored in the DSC facility. These messages should be stored until readout.

4.11.3.44 Distress information should be erased 48 hours after their reception. (*acc. to Res. MSC 68(68)*).

4.11.3.45 Initiation of DSC distress calls should supersede any other operation of the facility.

4.11.3.46 Self-identification data should be stored in the DSC unit. It should not be possible for the user easily to change these data.

4.11.3.47 Means should be provided to enable routine testing of the DSC facilities without radiation of signals.

4.11.3.48 Provision should be made for a specific aural alarm and visual indication to indicate receipt of a distress or urgency call or a call having distress category. It should not be possible to disable this alarm and indication. Provision should be made to ensure that they can be reset only manually.

4.11.4 MF/HF radio installations capable of voice communication, narrow-band direct-printing NBDP, and digital selective calling DSC (*acc. to Res. A.806(19) and MSC.68(68)*)

4.11.4.1 The MF/HF installation which may consist of more than one piece of equipment, should be capable of operating on single-frequency channels or on single- and two-frequency channels.

4.11.4.2 The MF/HF equipment should provide for the following categories of calling, using both voice and digital selective calling (DSC):

- .1 distress, urgency and safety;
- .2 ship operational requirements; and
- .3 public correspondence.

4.11.4.3 The MF/HF equipment should provide for the following categories of communications, using both voice and narrow-band direct printing (NBDP):

- .1 distress, urgency and safety;**
- .2 ship operational requirements; and**
- .3 public correspondence.**

4.11.4.4 The equipment should comprise at least:

- .1** a transmitter/receiver, including antenna(e);
- .2** an integral control unit and/or one or more separate control units;
- .3** a microphone with a press-to-transmit switch, which may be combined with a telephone in a handset;
- .4** an internal or external loudspeaker;
- .5** an integral or separate narrow-band direct-printing facility NBDP;
- .6** an integral or separate digital selective calling facility DSC; and
- .7** a dedicated DSC watchkeeping facility to maintain a continuous watch on distress channels only. Where a scanning receiver is employed to watch more than one DSC distress channel, all selected channels should be scanned within 2 s and the dwell time on each channel should be adequate to allow detection of the dot pattern which precedes each DSC call. The scan should only stop on detection of a 100 baud dot pattern.

4.11.4.5 The MF/HF distress alert should be activated only by means of a dedicated distress button. The dedicated distress button should be clearly identified and be protected against inadvertent operation. The distress alert initiation should require at least two independent actions. The equipment should indicate the status of the distress alert transmission.

4.11.4.6 It should be possible to interrupt and initiate distress alerts at any time.

4.11.4.7 The transmitter should be capable of transmitting on all frequencies allocated to the maritime mobile service in the frequency band 1,605 kHz to 27,500 kHz. As a minimum, the following frequencies should be readily accessible to the operator:

- .1** DSC frequencies: 2,187.5, 4,207.5, 6,312, 8,414.5, 12,577 and 16,804.5 kHz;
- .2** the voice frequencies: 2,182, 4,125, 6,215, 8,291, 12,290 and 16,420 kHz;
- .3** the NBDP frequencies 2,174.5, 4,177.5, 6,268, 8,376.5, 12,520 and 16,695 kHz.

4.11.4.8 Radiotelephone frequencies are designated in terms of the carrier frequency; NBDP and DSC frequencies are designated in terms of the assigned (centre) frequency. When NBDP and DSC signals are transmitted using a transmitter in the J2B mode the (suppressed) carrier frequency should be adjusted so as to have the NBDP and the DSC signal transmitted on the assigned frequency. The selected transmitter frequency should be clearly identifiable on the control panel of the equipment.

4.11.4.9 The transmitter should be capable of transmitting (upper side band signals, where appropriate) using classes of emission J3E, H3E and either J2B or F1B.

4.11.4.10 When switching to the preset distress frequency 2,182 kHz, the appropriate class of emission in accordance with the *Radio Regulations* should be selected automatically.

4.11.4.11 When switching to the assigned (centre) frequencies for NBDP and DSC specified in 1.1 above, classes of emission F1B or J2B should be selected automatically.

4.11.4.12 It should be possible to change the transmitter from any class of emission to another for which it is designed to operate by means of not more than one control.

4.11.4.13 It should be possible for the user to select transmission frequencies independent of any receiver setting. This does not preclude the use of transceivers.

4.11.4.14 It should be possible to change the transmitter quickly from operation on any frequency to operation on any other frequency, and in any event within a period not exceeding 15 s. The equipment should not be able to transmit during channel switching operations.

4.11.4.15 Means should be provided to prevent overmodulation automatically.

4.11.4.16 The transmitter frequency should remain within 10 Hz of the required frequency at all times following the warming-up period.

4.11.4.17 During normal modulation, the peak envelope power in the case of J3E or H3E emissions, or the mean power in the case of J2B or F1B emissions, should be at least 60 W at any frequency within the specified frequency range..

4.11.4.18 If the rated output power exceeds 400 W in the band, provision should be made for reducing the output to 400 W or less. Generally, only the minimum power necessary should be used for all radio communications.

4.11.4.19 The equipment should be capable of operation within 1 min after switching on.

4.11.4.20 Continuous operation should be possible when the transmitter is adjusted to operate at its rated power.

4.11.4.21 Provision should be made for indicating the antenna current or power delivered to the antenna. Failure of the indicating system should not interrupt the antenna circuit.

4.11.4.22 Manually tuned equipment should be fitted with a sufficient number of indicators to permit accurate and rapid tuning.

4.11.4.23 Operation of the transmit/receive control should not cause unwanted emissions.

4.11.4.24 All adjustment and controls necessary for switching the transmitter to operate on 2,182 kHz and 2,187.5 kHz should be clearly marked, in order that these operations may be performed readily.

4.11.4.25 The equipment should be so designed and constructed that when the transmitter is providing power to the antenna, the transmitter is protected against damage resulting from disconnection of the antenna or short-circuiting of antenna terminals. If this protection is provided by means of a safety device, that device should automatically be reset following removal of the antenna open-circuit or short-circuit conditions.

4.11.4.26 If it is necessary to delay the application of voltage, for example anode voltage, to any part of the transmitter after switching on, this delay should be provided automatically.

4.11.4.27 If the transmitter includes parts which are required to be heated in order to operate correctly, for example crystal ovens, the power supplies to the heating circuits should be so arranged that they can remain operative when other supplies to or within the equipment are switched off. If a special switch for the heating circuits is provided, its functions should be clearly indicated; it should normally be in the "on" position and be protected against inadvertent operation. The correct operating temperature should be reached within a period of 30 min after the application of power.

4.11.4.28 The receiver should be capable of being tuned throughout the bands between 1,605 kHz and 27.5 MHz. Tuning should be either continuous, or by incremental steps, or by the selection of a number of spot frequencies adequate for the operation of the ship, or by any combination of these methods. As a minimum, the following frequencies should be readily accessible to the operator:

- .1 the DSC frequencies 2,187.5, 4,207.5, 6,312, 8,414.5, 12,577 and 16,804.5 kHz;
- .2 the carrier frequencies 2,182, 4,125, 6,215, 8,291, 12,290 and 16,420 kHz for radiotelephony;
- .3 the NBDP frequencies 2,174.5, 4,177.5, 6,268, 8,376.5, 12,520 and 16,695 kHz.

4.11.4.29 Radiotelephone frequencies should be designated in terms of the carrier frequency; NBDP and DSC frequencies should be designated in terms of the assigned (centre) frequency. The selected receiver frequency should be clearly identifiable on the control panel of the equipment.

4.11.4.30 The receiver should be capable of receiving upper sideband signals as appropriate for classes of emission J3E, H3E, J2B and F1B. The class of emission should be selectable by not more than one control.

4.11.4.31 It should be possible for the user to select reception frequencies independent of any transmitter setting. This does not preclude the use of transceivers.

4.11.4.32 The receiver should be capable of being tuned to different frequencies quickly, and in any event within a period not exceeding 15 s.

4.11.4.33 The receiver frequency should at all times remain within 10 Hz of the required frequency following the warming-up period.

4.11.4.34 For classes of emission J3E and F1B the sensitivity of the receiver should be equal to or better than 6 μ V e.m.f. at the receiver input for a signal-to-noise ratio of 20 dB. For NBDP and DSC an output character error rate of 0,01 or less should be obtained for a signal-to-noise ratio of 12 dB.

4.11.4.35 For the reception of voice signals, the receiver should be suitable for use with a loudspeaker and a telephone handset and should be capable of providing power of at least 2 W to the loudspeaker and at least 1 mW to the handset.

4.11.4.36 An output should be provided for NBDP and DSC signals if the corresponding facility is not integrated.

4.11.4.37 The equipment should be capable of operating within 1 min after switching on.

4.11.4.38 The immunity to interference of the receiver should be such that the wanted signal is not seriously affected by unwanted signals.

4.11.4.39 The receiver should be provided with automatic gain control.

4.11.4.40 The DSC facility shall be of class A¹⁾.

4.11.4.41 The DSC facility should comprise:

- .1 means to decode and encode DSC messages;
- .2 means necessary for composing the DSC message;
- .3 means to verify the prepared message before it is transmitted;
- .4 means to display the information contained in a received call in plain language;
- .5 means for the manual entry of the position information; additionally, automatic entry may be provided; and (*acc. to Res. MSC 68(68)*);
- .6 A means to display, in plain language with a minimum of 160 characters in two or more lines, the information contained in a received call²⁾ (*acc. to Res. MSC 68(68)*);

¹⁾ Definicje klas DSC i związane z nimi wymagania zawarte są w Zaleceniu ITU-R M.493.

²⁾ Dotyczy urządzeń instalowanych na okręcie od 01.01.2000 r.

- .7 facilities to automatically update the ship's position and the time at which the position was determined from a suitable electronic position-fixing aid which may be an integral part of the equipment. For equipment which does not have an integral position-fixing aid, such facilities should include a suitable interface conforming to the IEC *Publication 1162*²⁾ (*acc. to Res. MSC 68(68)*);
- .8 means to activate an alarm when no position data is received from the electronic position-fixing aid or, in the case of manual input, the position information is over 4 hours old. Any position information not updated for more than 23,5 hours should be erased²⁾ (*acc. to Res. MSC 68(68)*).

4.11.4.42 If the received messages are not printed immediately, sufficient capacity should be provided to enable at least 20 received distress messages to be stored in the DSC facility. These messages should be stored until readout.

4.11.4.43 These messages should be stored until readout and should be erased 48 hours after their reception²⁾ (*acc. to Res. MSC 68(68)*).

4.11.4.44 Initiation of DSC distress calls should take precedence over any other operation of the facility.

4.11.4.45 Self-identification data should be stored in the DSC unit. It should not be possible for the user easily to change these data.

4.11.4.46 Means should be provided to enable routine testing of the DSC facilities without radiation of signals.

4.11.4.47 Provision should be made for a specific aural alarm and visual indication to indicate receipt of a distress or urgency call or a call having a distress category. It should not be possible to disable this alarm and indication. Provision should be made to ensure that they can be reset only manually.

4.11.4.48 The NBDP facility should be capable of operating in the FEC and ARQ modes on the single-frequency channels allocated for distress NBDP operation.

4.11.4.49 Self-identification data should be stored in the NBDP unit. It should not be possible for the user easily to change these data.

4.11.4.50 The NBDP facility should comprise:

- .1 means to decode and encode messages;
- .2 means for composing and verifying messages to be transmitted; and
- .3 means for providing a record of received messages.

4.11.4.51 NBDP equipment – detailed requirements (*acc. to Res. A.700(17)*)

4.11.4.51.1 The NBDP equipment should be capable of producing a printed copy of received information. The equipment functions should include signal reception, processing, printing and the means to control the frequency of the radio receiver both manually and automatically.

4.11.4.51.2 Details of the coverage areas and message categories which have been excluded by the operator from reception should be readily available

4.11.4.51.3 The NBDP receiver should operate on the frequencies prescribed by the *Radio Regulations* for the system.

4.11.4.51.4 The NBDP equipment should be provided with a facility to test that the radio receiver, signal processor and printing device are functioning correctly.

4.11.4.51.5 The NBDP equipment should be capable of internally storing at least 255 message identifications. After between 60 and 72 h a message identification should automatically be erased from the store. If the number of received message identifications exceeds the capacity of the store, the oldest message identification should be erased.

4.11.4.51.6 Only message identifications which have been satisfactorily received should be stored in NBDP, a message is satisfactorily received if the character-error ratio is below 4 %.

4.11.4.51.7 The receipt of search and rescue information should give an alarm at the position from which the ship is normally navigated. It should be possible only to reset this alarm manually.

4.11.4.51.8 Information for location (B1) and message (B2) designators in programmable memories should not be erased by interruptions in the power supply of less than 6 h.

4.11.4.51.9 The receiver sensitivity should be equal to or better than 6 μV e.m.f. at the receiver input to produce an NBDP output character-error rate of not greater than 10^{-2} .

4.11.4.51.10 The printing device should be able to print at least 32 characters per line.

4.11.4.51.11 If automatic line feed entails division of a word, this shall be indicated in the written text. The printing device should automatically feed paper after completing the printed message.

4.11.4.51.12 The equipment should print an asterisk if a character is received mutilated.

4.11.4.51.13 A UTC clock, accurate to at least one second, and associated with a reprogrammable memory which contains the frequency sequence and UTC broadcast schedules of all stations, should control the HF receiver to provide automatic MSI reception.

4.11.5 Ship earth station for satellite communications INMARSAT**4.11.5.1** General requirements (*acc. to Res. A.808(19), excluding 5.5.1.2*)

4.11.5.1.1 The ship earth station capable of two-way communications should be type approved by INMARSAT.

4.11.5.1.2 INMARSAT A, INMARSAT B and INMARSAT C ship earth stations fulfill the requirements for GMDSS system.

4.11.5.1.3 No control external to the equipment should be available for alteration of the ship station identity.

4.11.5.1.4 It should be possible to interrupt or initiate distress calls at any time.

4.11.5.1.5 Changing from one source of supply to another or any interruption up to 60 s of the supply of electrical energy should not render the equipment inoperative or require the equipment to be re-initialized.

4.11.5.1.6 Ship earth station INMARSAT and EGC receiver may be operated with omnidirectional or directive antenna.

4.11.5.2 Ship earth station INMARSAT C (*acc. to Res. A.807(19) and MSC.68(68)*)

4.11.5.2.1 The INMARSAT-C ship earth station installation capable of transmitting and receiving direct-printing communications may be integrated with the enhanced group call (EGC) receiver complying with the requirements of 4.11.6.

4.11.5.2.2 In addition to meeting the general requirements contained in section 4.11.5.1, for each type of INMARSAT station, station INMARSAT C should be equipped with a special alarm button, which shall be:

- .1 clearly identified; and
- .2 be protected against inadvertent operation.

4.11.5.2.3 Inicjacja alarmu powinna wymagać co najmniej dwóch niezależnych czynności.

4.11.5.2.4 The distress alert initiation should require at least two independent actions.

4.11.5.2.5 For INMARSAT C station provisions should be made for automatic and manual entry of the position information and of the time at which the position was determined.

4.11.5.2.6 facilities to automatically update the ship's position and the time at which the position was determined from a suitable electronic position-fixing aid which may be an integral part of the equipment. For equipment which does not have an integral position-fixing aid, such facilities should include a suitable interface conforming to the IEC *Publication 1162*¹⁾ (*acc. to Res. MSC 68(68)*).

¹⁾ Concerns the equipment installed on or after 01.01.2000 r.

4.11.5.2.7 means to activate an alarm when no position data is received from the electronic position-fixing aid or, in the case of manual input, the position information is over 4 hours old. Any position information not updated for more than 24 hours should be clearly indicated¹⁾ (*acc. to Res. MSC 68(68)*).

4.11.6 Enhanced group call receiver EGC (*acc. to Res. A.664(16)*)

4.11.6.1 EGC receiver designated for operation in INMARSAT system shall be of type approved by INMARSAT. The enhanced group call installation may be either separate or combined with ship earth station.

4.11.6.2 The EGC equipment should be capable of producing a printed copy of received information. Received EGC messages may be stored, with indication that the message has been received, for later printing, except for the distress messages, navigational and meteorological warnings, which should be printed out upon receipt.

4.11.6.3 Means should be provided to enter the ship's position and area code manually so that area group calls can be received. Optionally, the ship's position, as determined by the navigational equipment, may be entered automatically and the area code automatically derived from there.

4.11.6.4 Provision should be made for a specific aural alarm and visual indication at the position from which the ship is normally navigated to indicate receipt of a distress or urgency call or a call having distress category. It should be possible to reset this alarm only manually.

4.11.6.5 The EGC equipment should indicate when it is not correctly tuned or synchronized to the enhanced group call carrier.

4.11.6.6 Any message should be printed regardless of the character error rate of its reception. The equipment should print a low line mark if a character is received mutilated.

4.11.6.7 Means should be provided not to reprint the same message after it has been received without error. The printing device should be able to print at least 40 characters per line. If any word cannot be accommodated in full on one line, it should be transferred to the next line. The printing device should automatically feed five lines after completing the printed messages.

4.11.6.8 EGC receiver shall be so designed, that the equipment is unable to reject relevant navigational warnings, meteorological warnings, search and rescue information and certain special warnings, which are directed to a geographical area within which the ship is operating.

4.11.6.9 Changing from one source of supply to another, or any interruption of up to 60 s duration of the supply of electrical energy, should not require the equipment to be manually re-initialized and should not result in loss of received messages stored in the memory.

4.11.7 Navigational and meteorological warnings receiver NAVTEX (acc. to Res. A.525(13))

4.11.7.1 The NAVTEX equipment should comprise a radio receiver, a signal processor and a printing device. The equipment should also be provided with a facility to test that the devices are functioning correctly.

4.11.7.2 Details of the coverage areas and message categories which have been excluded by the operator from NAVTEX reception should be readily available.

4.11.7.3 The NAVTEX receiver should operate on the 518 kHz¹⁾ frequency. The equipment should be capable of internally storing at least 30 message identifications. After between 60 and 72 hours a message identification should automatically be erased from the store. If the number of received message identifications exceeds the capacity of the store, the oldest message identification should be erased.

4.11.7.4 Only message identifications which have been satisfactorily received by NAVTEX should be stored; a message is satisfactorily received if the character error rate is below 4%.

4.11.7.5 The receipt of search and rescue information should give an alarm at the position from which the ship is normally navigated. It should be possible only to reset this alarm manually.

4.11.7.6 Information for location (B₁) and message (B₂) designators in programmable memories should not be erased by interruptions in the power supply of less than 6 hours.

4.11.7.7 The receiver sensitivity should be such that for a source with an e.m.f. of 2µV in series with a non-reactive impedance of 50 ohms, the character error rate is below 4%.

4.11.7.8 The printing device should be able to print at least 32 characters per line.

4.11.7.9 If automatic linefeed entails division of a word, this shall be indicated in the written text. The printing device should automatically feed paper after completing the printed message.

4.11.7.10 The equipment should print an asterisk if a character is received mutilated.

¹⁾ Zgodnie z postanowieniem ITU o przydzieleniu transmisji NAVTEX dwóch dodatkowych częstotliwości: 490 kHz i 4209,5 kHz do stosowania od 01.02.1999 r., odbiornik NAVTEX może dodatkowo pracować na tych częstotliwościach po zakończeniu używania częstotliwości 500 kHz.

4.11.8 Float-Free satellite emergency position-indicating radio beacon (EPIRB) operating on 406 MHz (*acc. to Res. A.810(19)*), except of 4.11.8.5)

4.11.8.1 The satellite EPIRB operating on frequency 406 MHz should be capable of transmitting a distress alert to a polar orbiting satellite, and shall be of COSPAS-SARSAT type approved. It should be of an automatic float-free type. The equipment, mounting and releasing arrangements should be reliable, and should operate satisfactorily under the most extreme conditions likely to be met with at sea.

4.11.8.2 The satellite EPIRB should:

- .1 be fitted with adequate means to prevent inadvertent activation;
- .2 be so designed that the electrical portions are watertight at a depth of 10 m for at least 5 min. Consideration should be given to a temperature variation of 45°C during transitions from the mounted position to immersion. The harmful effects of a marine environment, condensation and water leakage should not affect the performance of the beacon;
- .3 be automatically activated after floating free;
- .4 be capable of manual activation and manual deactivation;
- .5 be provided with a fall permanently attached to it;
- .6 be provided with means to indicate that signals are being emitted;
- .7 be capable of floating upright in calm water and have positive stability and sufficient buoyancy in all sea conditions;
- .8 be capable of being dropped into the water without damage from a height of 20 m;
- .9 be capable of being tested, without using the satellite system, to determine that the EPIRB is capable of operating properly;
- .10 be of highly visible yellow/orange colour and be fitted with retroreflecting material;
- .11 be equipped with a buoyant lanyard suitable for use as a tether, which should be so arranged as to prevent its being trapped in the ship's structure when floating free;
- .12 be provided with a low duty cycle light (0.75 cd), active during darkness, to indicate its position to nearby survivors and to rescue units;
- .13 not be unduly affected by seawater or oil or both;
- .14 be resistant to deterioration in prolonged exposure to sunlight; and
- .15 be provided with a 121.5 MHz beacon primarily for homing by aircraft.

4.11.8.3 The satellite EPIRB shall operate with the omnidirectional antenna with vertical polarization.

4.11.8.4 The battery should have sufficient capacity to operate the satellite EPIRB for a period of at least 48 h.

4.11.8.5 The satellite EPIRB should be so designed as to operate under any of the following environmental conditions:

- .1 ambient temperatures of -20°C to +55°C
- .2 icing;
- .3 relative wind speeds up to 100 knots; and
- .4 after stowage, at temperatures between -30°C and +70°C.

4.11.8.6 The installed satellite EPIRB should:

- .1 have local manual activation; remote activation may also be provided from the navigating bridge, while the device is installed in the float-free mounting;
- .2 be capable, while mounted on board, of operating properly over the ranges of shock and vibration and other environmental conditions normally encountered above deck on seagoing ships; and
- .3 be designed to release itself and float free before reaching a depth of 4 m at a list or trim of any angle.

4.11.8.7 When the satellite EPIRB is manually operated a distress alert should be initiated only by means of a dedicated distress alert activator which should be clearly identified and protected against inadvertent operation. Manual distress alert initiation should require at least two independent actions.

4.11.8.8 The satellite EPIRB should not be automatically activated after being manually removed from the release mechanism.

4.11.8.9 The following should be clearly indicated on the exterior of the EPIRB:

- .1 brief operating instructions;
- .2 expiry date for the primary battery used; and
- .3 the identity code programmed into the transmitter.

4.11.8.10 The satellite EPIRB distress alerting signal should be transmitted on the frequency of 406.025 MHz using G1B class of emission. Provisions should be included for storing the fixed portion of the distress message in the satellite EPIRB using non-volatile memory

4.11.8.11 A unique beacon identification code should be made part of all messages. The identification code should include a 3-digit code for the country (MID) in which the beacon is registered, followed by either:

- .1 the trailing 6 digits of the ship station identity (MMSI), or
- .2 a unique serial number; or
- .3 a radio call sign.

4.11.8.12 The 121.5 MHz homing signal should:

- .1 have a continuous duty cycle, except that it may be interrupted for up to a maximum of 2 s during the transmission of the 406 MHz signal; and
- .2 with the exception of the sweep direction, meet the technical characteristics of Appendix 37A of the Radio Regulations. The sweep may be either upward or downward.

4.11.8.13 Float-free release and activation arrangements for emergency radio equipment EPIRB (acc. to Res. A.662(16))

4.11.8.13.1 EPIRB float-free release and activation arrangements enable the automatic release of specified radio apparatus from a sinking ship and its automatic activation.

4.11.8.13.2 The float-free arrangement should:

- .1 be designed so that the release mechanism should operate before reaching a depth of 4 m in any orientation;
- .2 be capable of operating throughout the temperature range of -30°C to +65°C;
- .3 be constructed of non-corrosive compatible materials, so as to prevent deterioration which may cause any malfunction of the unit. Galvanizing or other forms of metallic coating on parts of the float-free release mechanism should not be accepted;
- .4 be constructed to prevent release when seas wash over the unit;
- .5 not be unduly affected by seawater or oil or prolonged exposure to sunlight;
- .6 be capable of operating properly after exposure to shock and vibration and other severe environmental conditions encountered above deck on seagoing ships;
- .7 if the ship navigates in areas where icing may be expected, be so designed as to minimize the formation of ice and prevent its effects from hindering the release of the radio equipment as far as practicable;
- .8 be mounted in such a way that the radio equipment, after being released, is not obstructed by the structure of the sinking ship; and
- .9 carry a label indicating clearly the operating instructions for manual release..

4.11.8.13.3 It should be possible to assess the proper functioning of the automatic release mechanism by a simple method without activation of the radio equipment.

4.11.8.13.4 It should be possible to release the radio equipment manually from the float-free mechanism.

4.11.9 Radar transponder SART (acc. to Res. A.802(19))

4.11.9.1 The radar transponder SART, operating on 9 GHz frequency, should be capable of indicating the location of a unit in distress on the assisting units radars by means of a series of equally spaced dots.

4.11.9.2 The SART should:

- .1 be capable of being easily activated by unskilled personnel;
- .2 be fitted with means to prevent inadvertent activation;
- .3 be equipped with a means which is either visual or audible, or both visual and audible, to indicate correct operation and to alert survivors to the fact that a radar has triggered the SART;

- .4 be capable of manual activation and deactivation; provision for automatic activation may be included¹⁾;
- .5 be provided with an indication of the stand-by condition;
- .6 be capable of withstanding without damage drops from a height of 20 m into water;
- .7 be watertight at a depth of 10 m for at least 5 min;
- .8 maintain watertightness when subjected to a thermal shock of 45°C under specified conditions of immersion;
- .9 be capable of floating if it is not an integral part of the survival craft;
- .10 be equipped with buoyant lanyard, suitable for use as a tether, if it is capable of floating;
- .11 not be unduly affected by seawater or oil;
- .12 be resistant to deterioration in prolonged exposure to sunlight;
- .13 be of a highly visible yellow/orange colour on all surfaces where this will assist detection;
- .14 have a smooth external construction to avoid damaging the survival craft; and
- .15 be provided with a pole or other arrangement compatible with the antenna pocket in a survival craft, together with illustrated instructions, at the height of at least 1 m above sea-level.

4.11.9.2.1 The SART should have sufficient battery capacity to operate in the stand-by condition for 96 h and, in addition, following the stand-by period, to provide transponder transmissions for 8 h when being continuously interrogated with a pulse repetition frequency of 1 kHz.

4.11.9.2.2 The SART should be so designed as to be able to operate under ambient temperatures of -20°C to +55°C. It should not be damaged in stowage throughout the temperature range of -30°C to +65°C.

4.11.9.2.3 The vertical polar diagram of the antenna and hydrodynamic characteristics of the device should permit the SART to respond to search radars under heavy swell conditions. The polar diagram of the antenna should be substantially omnidirectional in the horizontal plane. Horizontal polarization should be used for transmission and reception.

4.11.9.2.4 The SART should operate correctly when interrogated at a distance of up to at least 5 nautical miles by a navigational radar with an antenna height of 15 m. It should also operate correctly when interrogated by an airborne radar with at least 10 kW peak output power at a height of 900 m.

4.11.9.2.5 The following should be clearly indicated on the SART exterior

- .1 brief operating instructions; and
- .2 expiry date for the primary battery used.

¹⁾ If an on-board test is performed using a shipborne 9 GHz radar, activation of the SART should be limited to a few seconds to avoid harmful interference with other shipborne radars and excessive

4.11.10 Survival craft two-way VHF radiotelephone apparatus

(acc. to Res. A.809(19))

4.11.10.1 Two-way VHF radiotelephone for on-scene rescue action communication may be portable or stationary device. Due to general lack of interest in a stationary version of the device in these Rules only the requirements for portable devices are included.

4.11.10.2 A portable VHF for on-scene communication with survival crafts should comprise at least:

- .1 an integral transmitter/receiver including antenna and battery;
- .2 an integral control unit including a press-to-transmit switch; and
- .3 an internal microphone and loudspeaker.

4.11.10.3 The VHF equipment should:

- .1 be capable of being operated by unskilled personnel;
- .2 be capable of being operated by personnel wearing gloves as specified for immersion suits;
- .3 be capable of single-handed operation except for channel selection;
- .4 withstand drops on to a hard surface from a height of 1 m;
- .5 be watertight to a depth of 1 m for at least 5 min;
- .6 maintain watertightness when subjected to a thermal shock of 45°C under conditions of immersion;
- .7 not be unduly affected by seawater, or oil, or both;
- .8 have no sharp projections which could damage survival craft;
- .9 be of small size and light weight;
- .10 be capable of operating in the ambient noise level likely to be encountered on board ships or in survival craft
- .11 have provisions for its attachment to the clothing of the user;
- .12 be resistant to deterioration by prolonged exposure to sunlight; and
- .13 be either of a highly visible yellow/orange colour or marked with a surrounding yellow/orange marking strip.

4.11.10.4 The two-way radiotelephone VHF should be capable of operation on the frequency 156.800 MHz (VHF channel 16) and on at least one additional channel

4.11.10.5 All channels fitted should be for single-frequency voice communication only.

4.11.10.6 An on/off switch should be provided with a positive visual indication that the radiotelephone is switched on.

4.11.10.7 The receiver should be provided with a manual volume control by which the audio output may be varied.

4.11.10.8 The portable VHF should be provided with a squelch (mute) control and a channel selection switch. Channel selection should be easily performed and the channels should be clearly discernible.

4.11.10.9 It should be possible to determine that channel 16 has been selected in all ambient light conditions.

4.11.10.10 The portable VHF equipment should be operational within 5 s of switching on.

4.11.10.11 The antenna should be vertically polarized and, as far as practicable, be omnidirectional in the horizontal plane. The antenna should be suitable for efficient radiation and reception of signals at the operating frequency.

4.11.10.12 The equipment should not be damaged by the effects of open-circuiting or short-circuiting the antenna.

4.11.10.13 The effective radiated power should be a minimum of 0.25 W. Where the effective radiated power exceeds 1 W, a power reduction switch to reduce the power to 1 W or less is required. When this equipment provides for on-board communications, the output power should not exceed 1 W on these frequencies.

4.11.10.14 The sensitivity of the receiver should be equal to or better than 2 μ V e.m.f. for a SINAD ratio of 12 dB at the output.

4.11.10.15 The immunity to interference of the receiver should be such that the wanted signal is not seriously affected by unwanted signals.

4.11.10.16 The audio output should be sufficient to be heard in the ambient noise level likely to be encountered on board ships or in a survival craft. In the transmit condition, the output of the receiver should be muted.

4.11.10.17 The VHF equipment should be so designed as to operate over the temperature range -20°C to $+55^{\circ}\text{C}$. It should not be damaged in stowage throughout the temperature range -30°C to $+70^{\circ}\text{C}$.

4.11.10.18 The source of energy should be integrated in the equipment and may be replaceable by the user. In addition, provision may be made to operate the equipment using an external source of electrical energy.

4.11.10.19 The VHF equipment for which the source of energy is intended to be user-replaceable should be provided with a dedicated primary battery for use in the event of a distress situation. This battery should be equipped with a non-replaceable seal to indicate that it has not been used

4.11.10.20 Equipment for which the source of energy is intended to be non-user-replaceable should be provided with a primary battery. The portable two-way radio-telephone equipment should be fitted with a non-replaceable seal to indicate that it has not been used.

4.11.10.21 The primary battery should have sufficient capacity to ensure 8-hour operation at its highest rated power with a duty cycle of 1:9. This duty cycle is defined as 6-second transmission, 6-second reception above squelch opening level and 48-second reception below squelch opening level.

4.11.10.22 Primary batteries should have a shelf life of at least 2 years, and if identified to be user-replaceable should be of a yellow/orange colour or marked with a surrounding yellow/orange marking strip.

4.11.10.23 Batteries not intended for use in the event of a distress situation (secondary batteries) should be of a colour or marking such that they cannot be confused with batteries intended for such use.

4.11.10.24 On the exterior of the equipment brief operating instructions and expiry date for the primary batteries should be clearly indicated.

4.11.11 Integrated radiocommunication system IRCS (*acc. to Res. A.811(19)*)

4.11.11.1 The IRCS is a system in which individual radiocommunication equipment and installations are used as sensors, i.e. without the need for their own control units, providing outputs to and accepting inputs from the operator's position, called workstations.

4.11.11.2 Such workstations are called "GMDSS workstations" if they include control and monitoring of all equipment and installations provided on a ship for the GMDSS which are also suitable for general radiocommunications.

4.11.11.3 In addition to meeting the general requirements contained in this chapter, concerning the radio equipment and installations, the system shall ensure compliance with IRCS relevant functional requirements provided for in the GMDSS. Functional parameters of individual radio devices should not impair the functional capacity of other radio devices integrated in the system IRCS.

4.11.11.4 Functional properties of the devices integrated in IRCS system shall comply with the relevant requirements specified for these devices in the present chapter.

4.11.11.5 No single fault in a system should impair the operation of more than one radiocommunication sensor or more than one workstation at any time.

4.11.11.6 The IRCS should:

- .1 comprise at least two GMDSS workstations each connected to each GMDSS radiocommunication sensor over a network or connecting system;
- .2 comprise at least two printers;
- .3 have facilities for automatically updating ship's position and time data in addition to the provision for manual input of this data;
- .4 have a power supply arrangement which ensures that it is not possible inadvertently to switch off any part of the IRCS;
- .5 include detecting facilities such that failure of any part of the IRCS activates an alarm; and
- .6 be protected against the effects of computer viruses.

4.11.11.7 The GMDSS workstations should:

- .1 have an identical user interface and an identical access to each function for different sensors;
- .2 be capable of being operated independently of each other;
- .3 be capable of allowing simultaneous operation of at least two GMDSS radiocommunication sensors; and
- .4 be capable of transmitting distress alerts. The distress alert should only be initiated by means of a dedicated button for each GMDSS sensor; the button should not be used for any other purpose. Each button should be clearly identified, protected against inadvertent operation, require two independent actions to initiate the distress alert and produce an indication that the distress alert has been activated. Each distress alerting button should be electrically separate from the IRCS network or connecting system. It should be possible to interrupt or initiate the distress alert at any time.

4.11.11.8 Integration of the VHF radiotelephone required for navigational safety should only be permitted if it does not prevent compliance with 4.7.1.3.

4.11.11.9 Additional workstations intended only for general radiocommunications should not have access to the distress alerting functions; neither should they impair or slow down the distress alerting and alarm functions. The GMDSS workstations should have priority access over additional workstations.

4.11.11.10 Additional sensors not required for the GMDSS should neither impair nor slow down the distress alerting and alarm functions.

4.12 Shipborne radio installations maintenance requirements

(acc. to SOLAS IV/15)

4.12.1 Radio equipment shall be so designed that the main units can be replaced readily, without elaborate recalibration or readjustment.

4.12.2 Where applicable, radio equipment shall be so constructed and installed that it is readily accessible for inspection and on-board maintenance purposes.

4.12.3 Adequate information shall be provided to enable the equipment to be properly operated and maintained in accordance with the requirements of 4.11.1.

4.12.4 Adequate tools and spares shall be provided to enable the equipment to be maintained.

4.12.5 It shall be ensured that radio equipment is maintained to provide the availability of the functional requirements of 4.4.1 and to meet the recommended performance standards of such equipment.

4.12.6 On ships engaged on voyages in sea areas A1 and A2, the availability shall be ensured by using such methods as duplication of equipment, shore-based maintenance or at-sea electronic maintenance capability, or a combination of these. Information on applied method shall be transmitted PRS.

4.12.7 On ships engaged on voyages in sea areas A3 and A4, the availability shall be ensured by using combination of at least two methods as duplication of equipment, shore-based maintenance or at-sea electronic maintenance capability, or a combination of these. Information on applied method shall be transmitted PRS.

4.12.8 Satellite EPIRBs shall be periodically tested for all aspects of operational efficiency, with special emphasis on checking the emission on operational frequencies, coding and registration at intervals not exceeding 12 months. However, where this is appropriate and justified, this period may be extended to 17 months. The test may be conducted on board the ship or at an approved testing station¹⁾.

4.12.9 Every satellite EPIRB shall, at intervals not exceeding 5 years, be shore-based tested and maintained by the service company approved by the manufacturer (*MSC/Circ.1039*).

4.13 Radio personnel (*acc. to SOLAS IV/16*)

4.13.1 Every ship shall carry personnel qualified for distress and safety radio-communication purposes for the safety assurance. The personnel shall be holders of certificates specified in the *Radio Regulations* as appropriate, any one of whom shall be designated to have primary responsibility for radiocommunications during distress incidents.

4.13.2 It is recommended that, depending on sea areas, at least two crew members hold the following:

- .1** for sea areas: A1+A2, A1+A2+A3 and A1+A2+A3+A4:
 - (General Operator Certificate – GOC; or
 - Radio Electronic Certificate – REC;
- .2** for sea area A1:
 - Restricted Operator's Certificate – REC.

4.14 Radio records

4.14.1 A record shall be kept of all incidents connected with the radiocommunication service, which appear to be of importance to safety of life at sea. The scope of records shall conform to the requirements of the *Radio Regulations*.

4.15 Position-updating¹⁾

4.15.1 All two-way communication equipment carried on board a ship to which the present chapter 4 applies, which is capable of automatically including the ship's position in the distress alert, shall be automatically provided with this information from an internal or external navigational receiver.

¹⁾ In force from 01.07.2002

¹⁾ In force from 01.07.2002 r.

5 REQUIREMENTS RELATING TO SOLAS CONVENTION, CHAPTER V – SAFETY OF NAVIGATION

5.1 Application

5.1.1 The present Chapter 5 applies to ships for which, on the basis of the Purchaser decision, relevant requirements of *SOLAS Convention 1974, Chapter V – Safety of navigation*, are to be complied with.

5.1.2 The present Chapter does not apply to navigational equipment and systems designated for commanding the ship, as well as for operational and tactical purposes.

5.1.3 The ships constructed on or after 1 July 2002 r. shall be equipped with the navigational systems and equipment prescribed in sub-chapter 5.4.

5.1.4 The ships constructed before 1 July 2002 r. shall be equipped with the navigational systems and equipment prescribed in sub-chapter 5.5.

5.1.5 It is permitted to provide the ship with additional navigational equipment not presented in the present chapter provided that its arrangement and operation shall not interfere operation of the main navigational equipment.

5.1.6 In the case that the ship constructed before 1 July 2002 is being additionally equipped with the navigational equipment required in the present chapter, she shall be considered as a new construction.

5.1.7 The requirements of the chapter 5 comply with the technical requirements of *SOLAS Convention 1974* and in adopted, currently in force, amendments, as well as comprise requirements of applicable IMO resolutions.

5.1.8 The present chapter contains technical requirements for shipborne navigational equipment, and determines the scope of equipment in ships, its installation and means of electrical power supply.

5.2 Definitions and abbreviations

5.2.1 Definitions

Acquisition – the process of selecting a target or targets and initiating their tracking.

Point setting error– the difference between heading of point setting and real heading.

Certificate – one of the Certificates issued for the ship in compliance with, *SOLAS 74 Convention*.

Electronic navigational map ENC – the database, standardized as to content, structure and format, issued for use with ECDIS on the authority of the government by the authorized hydrographic offices.

True heading – horizontal angle between the vertical plane passing through the actual meridian and the plane of symmetry of the ship.

Heading of set point – the average value of ten readings taken at ten-minute intervals after setting the compass.

Navigational bridge, bridge – an area from which the ship is navigated and controlled, comprising of the wheelhouse and the bridge wings.

Navigation – all activities relating to route planning, establishing and maintenance of ship motion parameters for the completion of the planned route, depending on the sea areas, their sailing conditions, and the traffic of other objects.

Motion parameters – heading and speed (motion vector).

Passenger – every person on the ship with the exception of the commander of the ship and crew members or other persons engaged in any capacity for the ship's needs (specialistic personnel), and with the exception of children under the age of one year and persons necessary during the sea trials.

Route planning – determining geographical co-ordinates of points on the sea, through which she has to sail in order to achieve safely a destination point.

Raster navigational chart RNC – standard representation as to the paper map content, issued by the hydrographical office authorized by the administrations, designed to be used in RCDS indicators..

Standard display – the SENC information that should be shown when a chart is first displayed on ECDIS.

Navigation and manoeuvring workstation – the workstation at which the ship's motion parameters and navigation situation around are controlled, and from which the ship is manoeuvred.

Manual steering workstation – the workstation from which manual steering of the ship may be performed.

Workstation – the station at which may be performed one or more activities comprising the specific activity.

Wheelhouse – an enclosed space of the bridge, from which the ship is navigated and controlled.

System electronic navigational map SENC – the database originated from transformation of electronic navigational chart ENC, comprising amendments and additional data introduced by the ECDIS operator.

Tracking – the computer process of observing the sequential changes in the position of a target in order to establish its motion.

5.2.2 Applied abbreviations

ARPA	– Automatic Radar Plotting Device
ATA	– Automatic Tracking Aid
AIS	– Automatic Identification System
CPA	– Closest Point of Approach
DGLONASS	– Differential Global Navigation Satellite System

DGPS	– Differential Global Positioning System
DSC	– Digital Selective Calling
ECDIS	– Electronic Chart Display and Information System
ENC	– Electronic Navigational Chart
EPA	– Electronic Plotting Aid
GLONASS	– Global Navigation Satellite System
GPS	– Global Positioning System
MMSI	– Maritime Mobile Service Identity
RCDS	– Raster Chart Display System
RNC	– Raster Navigational Chart
S.A.	– Selective Availability
SENC	– System Electronic Navigational Chart
SRNC	– System Raster Navigational Chart
TCPA	– Time to Closest Point of Approach
THD	– Transmitting Heading Device
TMHD	– Transmitting Magnetic Heading Device
UTC	– Universal Time Coordinated
VDR	– Voyage Data Recorder
VHF	– Very High Frequency ranging 30÷300 MHz
VTs	– Vessel Traffic System
WGS 84	– World Geodetic System 84

5.3 Scope of supervision

5.3.1 Statutory supervision covers design, manufacture, installation and operation of the following navigational equipment:

- master, steering and boat magnetic compasses;
- gyro-compasses;
- speed indicators;
- echo-sounding devices;
- rate-of-turn indicators;
- radars;
- automatic radar plotting devices (ARPA);
- automatic tracking aids (ATA);
- electronic tracking aids (ETA);
- electronic chart display and information system (ECDIS);
- radionavigational system receivers;
- automatic identification systems (AIS);
- voyage data recorders (VDR);
- transmitting magnetic heading devices (TMHD);
- transmitting heading devices (THD);
- daylight signalling lamp;
- sound receiving and amplification systems;
- other than listed above navigational equipment, indicated by the Purchaser.

Navigational equipment and systems, installed on the ships subject to PRS supervision, shall be of type approved by PRS. As an equivalent to navigational equipment supervised in accordance to this provision PRS may accept the equipment with relevant certificates and documents, e.g. issued in effect of conformity assessment procedures concerning the marine equipment, laid down in EU Directive 96/98/WE.

5.3.2 Systems and equipment, including associated back-up arrangements, installed on or after 1 July 2002 to perform the functional standards of 5.4 shall conform to appropriate performance requirements given in 5.7 (*acc. to SOLAS V/18*).

5.3.3 Systems and equipment replaced or added to on ship constructed before 1 July 2002 shall, in so far as reasonable and practicable, comply with the requirements of 5.3.4 (*acc. to SOLAS V/18*).

5.3.4 Systems and equipment installed prior to the adoption of performance standards may subsequently be exempted from full compliance with such standards (*acc. to SOLAS V/18*).

5.3.5 However for electronic chart display and information system (ECDIS) to be accepted as satisfying the chart carriage requirements of 5.4.2.4, that system shall conform to the relevant standards not inferior to those adopted on the date of installation, or, for systems installed before 1 January 1999, not inferior to the performance standards of 5.7.19.1 do 5.7.19.16 (*acc. to SOLAS V/18*).

5.3.6 When combining navigation equipment listed in 5.3.2 in integrated navigation systems, binding are technical-operational and installation requirements given in this chapter for each device component, and any additional requirements determined by the PRS in each case depending on the proposed solution.

5.3.7 The technical requirements for navigation equipment not mentioned in 5.3.2, and requirements for their installation on the ship are in each case separately determined by the PRS.

5.3.8 Equivalent equipment, that can be installed in lieu of the equipment listed in subsection 5.4, shall be of a type approved by PRS. An additional requirement for an equivalent equipment type approval is meeting the function required for the equipment listed in 5.4.

5.3.9 Prior to commencement of the ship construction, or installation of a new navigation equipment on the existing ship, PRS shall be provided, for approval, with the following technical documentation in a scope adequate to the ship's type:
technical description of the ship;

- list of navigation equipment with indication of types and manufacturers;
- diagrams of the main installation of the navigation equipment indicating type of cables, sources of power and description of the compartments in which particular equipment blocks are located;

- arrangement plans of navigation equipment and their sources of energy in all compartments in which they are located, presenting means of heating, ventilation, signalling and lighting;
- identification of the equipment earthing;
- means of radio reception protection against interference produced by the ship electrical equipment;
- common plans of antennas of the radio and navigation equipment (at least two views).

5.3.10 Installation of the navigation equipment on the ship, as well as actuation shall be performed by the PRS approved service company only. Acceptance of the installation and the equipment operation shall be performed by PRS Surveyor.

5.3.11 PRS may, taking into account the impact it would have on the safety of other objects, allow a partial or conditional waiver on some of the requirements of this chapter and/or consider an equivalent solution if the ship undertakes such voyages, that the largest distance between the ship and the shore, nature of the voyage, lack of significant navigational obstacles to, and other conditions affecting the safety make the full application of these requirements not necessary.

5.4 Carriage requirements for shipborne navigational systems and equipment for ships constructed on or after 1 July 2002 (SOLAS V/19))

5.4.1 The ship constructed on or after 1 July 2002 shall be fitted with navigational systems and equipment which will fulfil the requirements prescribed in 5.4.2.

5.4.2 Each ship, irrespective of size, shall be equipped with:

- .1** a properly adjusted magnetic compass to determine the ship's heading and display the reading at steering position;
- .2** a pelorus or compass bearing device independent of any power supply, to take bearings over an arc of the horizon of 360°;
- .3** means of correcting heading and bearings to true at all times;
- .4** nautical charts and nautical publications to plan and display the ship's route for the intended voyage and to plot and monitor positions through the voyage. An electronic chart display and information system (ECDIS) may be accepted as meeting the chart carriage requirement of this paragraph;
- .5** back-up arrangements to meet the functional requirements of .4, if this function is partly or fully fulfilled by electronic means¹⁾;
- .6** a receiver for global navigation satellite system (e.g.. GPS) or a terrestrial radionavigation system, or other means suitable for use at all times throughout the intended voyage to establish and update the ship's position by automatic means;

¹⁾ An appropriate folio of proper nautical charts may be used as a back-up arrangement for ECDIS.

- .7 if less than 150 gross tonnage and if practicable, a radar reflector, or other means, to enable deflection by ships navigating by radar at both 9 and 3 GHz;
- .8 when the ship's bridge is totally enclosed and unless PRS determines otherwise, a sound reception system, or other means, to enable the officer in charge of the navigation watch to hear sound signals and determine their direction;
- .9 a telephone, or other means, to communicate heading information to the emergency steering position, if provided.

5.4.3 All ships of 150 gross tonnage and upwards shall, in addition to the requirements of 5.4.2, be fitted with:

- .1 A spare magnetic compass, interchangeable with the magnetic compass as referred to in 5.4.2.1, or other means to perform the function referred to in 5.4.2.1 by means of replacement or duplicate equipment;
- .2 A daylight signalling lamp to communicate by light during day and night using an energy source of electrical power not solely dependent upon the ship's power supply.

5.4.4 All ships of 300 gross tonnage and upwards shall, in addition to meeting the requirements of w 5.4.3, be equipped with:

- .1 an echo-sounding device to measure and display the available depth of water;
- .2 a 9 GHz radar to determine and display the range and bearing of radar transponders and of other surface craft, obstructions, buoys, shorelines and navigational marks to assist in navigation and in collision avoidance;
- .3 an electronic plotting aid (EPA) to plot electronically the range and bearing of targets to determine collision risk;
- .4 speed and distance measuring device to indicate speed and distance through the water;
- .5 a properly adjusted transmitting heading device (THD) to transmit heading information for input to the equipment referred to in 5.4.4.2, 5.4.4.3 i 5.4.5.

Electronic plotting aids (EPA), as well as transmitting heading (THD) are obligatory only for ships of gross tonnage less than 500. Above that tonnage in lieu of the above means automatic tracking aid (ATA) and gyro-compass shall be provided.

5.4.5 It is recommended that all ships of 300 gross tonnage and upwards engaged on international voyages, and all ships of 500 gross tonnage and upwards not engaged on international voyages shall be fitted with an automatic identification system (AIS), as follows:

- .1 all ships constructed on or after 1 July 2002;
- .2 ships engaged on international voyages, constructed before 1 July 2002:
- .3 .2.1 in the case of tanker not later than the first safety equipment survey on or after 1 July 2003;
- .4 .2.2 in the case of ships other than tanker of 50,000 gross tonnage and upwards not later than 1 July 2004;

- .5 .2.3 in the case of ships other than tanker of of 300 gross tonnage and upwards, but less than 50,000 gross tonnage not later than the first safety equipment survey on or after 1 July 2004 or by 31 December 2004, whichever occurs earlier;
- .6 ships not engaged on international voyages constructed before 1 July 2002 not later than 1 July 2008.

5.4.6 All ships of 500 gross tonnage and upwards shall, in addition to meeting the requirements of 5.4.4 and 5.4.5, with the exception of 5.4.4.3 i 5.4.4.5, be equipped with:

- .1 a gyro-compass to determine and display their heading and to transmit heading information for input tot he equipment referred to in 5.4.4.2 (radar), 5.4.5 (AIS) and 5.4.6.5 (ATA);
- .2 a gyro compass heading repeater to supply heading information visually at the emergency steering position, if provided;
- .3 a gyro-compass repeater to take bearings, over an arc of the horizon of 360°, However PRS, for ships of less than 1,600 gross tonnage, may grant exemption from this requirement;
- .4 rudder, propeller, thrust, pitch and operational mode indicators to determine and display rudder angle, propeller revolutions, the force and direction of thrust and, if applicable, the force and direction of lateral thrust and the pitch and operational mode. All indicators to be readable from the conning position; and
- .5 an automatic tracking aid (ATA) to plot automatically the range and bearing other targets to determine collision risk.

5.4.7 All ships of 3,000 gross tonnage and upwards shall, in addition to meeting the requirements of 5.4.6, be provided with:

- .1 a radar 3 GHz or, alternatively, second radar 9 GHz functionally independent that referred to in 5.4.4.2; and
- .2 a second automatic tracking aid to plot automatically the range and bearing (ATA) (to radar referred to above) functionally independent of that required in 5.4.6.5.

A second automatic tracking aid (ATA) is required only on ships of less than 10,000 gross tonnage. For ships of 10,000 gross tonnage and upwards in lieu of automatic tracking aid (ATA) – automatic radar plotting aid (ARPA) is required.

5.4.8 All ships of 10,000 gross tonnage and upwards shall, in addition to meeting the requirements of 5.4.7 , with exception of 5.4.7.2, be equipped with:

- .1 an automatic radar plotting aid (ARPA) to plot automatically the range and bearing of at least 20 other targets, connected to device to indicate speed and distance through the water, to determine collision risk and simulate a trial manoeuvre; and
- .2 a heading track control system to automatically control and keep to heading and/or straight track.

5.4.9 Instead of equipment referred to in 5.4.2.1, 5.4.2.2, 5.4.3, 5.4.4, 5.4.6÷5.4.8 PRS may allow the installation of equivalents provided that they are PRS type approved.

5.4.10 Voyage data recorders (VDR) (acc. to SOLAS V/20)

It is recommended that all ships of 3,000 gross tonnage and upwards, constructed on or after 1 July 2002, engaged on international voyages, subject to the provisions 5.4.1, shall be equipped with voyage data recorder (VDR).

5.4.11 Nautical publications (acc. to SOLAS V/27)

All ships shall be provided with adequate, up to date charts, sailing directions, lists of lights, notices to mariners, tide tables and all other nautical publications necessary for the intended voyage.

5.5 Carriage requirements for shipborne navigational equipment on ships constructed before to 1 July 2002

5.5.1 Ships constructed before 1 July 2002 shall:

- .1 subject to the provisions of 5.5.1.2 and 5.5.1.3, unless they comply fully with the regulation 5.4, continue to be fitted with equipment which fulfills the requirements of 5.5.2÷5.5.11 (acc. to SOLAS 74 before introduction of Amendments 2000, Chapter V, Regulations 11, 12 and 20), in force prior to 1 July 2002;
- .2 be fitted, instead of the radio direction-finding apparatus, with a receiver for global navigation satellite system (e.g. GPS), or a terrestrial radionavigation system required by 5.4.2.6;
- .3 be fitted with an automatic identification system AIS required by 5.4.5, not later than on dates prescribed in 5.4.5.4 i 5.4.5.3, and
- .4 be fitted with a voyage data recorder (VDR) required by 5.4.11, on the following dates:
 - .5 ships of 20,000 gross tonnage and upwards– not later than 1 January 2007;
 - .6 ships of 3,000 gross tonnage and upwards, but less than 20,000 gross tonnage– not later than 1 January 2008;

5.5.2 Magnetic compasses (acc. to SOLAS V/12(b), 12(c))¹⁾

5.5.2.1 Every ship of displacement 150 t and greater shall carry::

- .1 the standard magnetic compass, except of the case described in 5.5.2.4;
- .2 a steering magnetic compass, unless the heading information provided by the standard compass, required under .1, is made available and clearly readable by the helmsman at the main steering position;

¹⁾ Referred to in 5.5.2 ÷ 5.5.12 requirements acc. to SOLAS relate to SOLAS 74 Convention prior to introduction of Amendments 2000.

- .3 adequate means of communication between the standard compass position and the normal navigation control position;;
- .4 means for taking bearings as nearly as practicable over an arc of horizon of 360°.

5.5.2.2 Each magnetic compass, referred to in 5.5.2.1.1, shall be properly compensated and its table or curve of residual deviations is available on board at all times.

5.5.2.3 A spare magnetic compass, interchangeable with the standard compass, unless a gyro-compass or the steering compass mentioned in 5.5.2.1.2 is fitted.

5.5.2.4 PRS may exempt individual ship or classes of ships from the requirement of 5.5.2.3, if the nature of the voyage, the ship's proximity to land or the type of ship, considers it unreasonable or unnecessary to require a standard magnetic compass, provided that a suitable steering compass is in all cases carried.

5.5.2.5 The ship of displacement less than 150 t shall, as far as PRS considers if reasonable and practicable, be fitted with a steering compass and have means for taking bearing.

5.5.3 Gyro-compasses (*acc. to SOLAS V/12(d), 12(e)*)

5.5.3.1 The ship of displacement of 500 t and upwards, constructed on or after 1 September 1984, shall be fitted with a gyro-compass complying with the following requirements:

- .1 the master gyro-compass or a gyro repeater shall be clearly readable by the helmsman at the main steering position;
- .2 on ships of displacement 1600 t and upwards a gyro repeater gyro repeaters shall be provided and shall be suitably placed for taking bearings as nearly as practicable over an arc of the horizon of 360°.

5.5.3.2 The ship of displacement of 1600 t and upwards, constructed before 1 September 1984, when engaged on international voyages, shall be fitted with a gyro-compass complying with the requirements of paragraph 5.5.2.1

5.5.4 Communication means for emergency steering position (*acc. to SOLAS V/12(f)*)

Ships with emergency steering position shall be at least provided with a telephone or other means of communication for relaying heading information to such position. In addition, ships of displacement 500 t and upwards constructed on or after 1 February 1992, shall be provided with arrangements for supplying visual compass readings to the emergency steering position.

5.5.5 Radars (*acc. to SOLAS V/12(f)÷12(i)*)

5.5.5.1 Ships of displacement 500 t and upwards, constructed on or 1 September 1984, as well as ships of displacement 1600 t and upwards, constructed before 1 September 1984, shall be fitted with a radar installation. From 1 February 1995, the radar installation shall be capable of operating in the 9GHz frequency band. In the case of ships constructed after 1 February 1995 the requirement of radar installation capable of operating in the 9GHz frequency band is obligatory for ships of displacement 300t and upwards. Radars installed on ships of displacement 330 t and upwards, but less than 500t may be exempted from compliance with the requirements of 5.5.5.1 at the PRS discretion, provided that the equipment is fully compatible with the radar transponder for search and rescue.

5.5.5.2 Ships of displacement 10 000 t and upwards shall be fitted with two radar installations, each capable of being operated independently. From 1 February 1995 at least one of the radar installations shall be capable of operating in the 9GHz frequency band.

5.5.5.3 Facilities for plotting radar readings shall be provided on the navigation bridge of ships required by paragraph 5.5.5.1 or 5.5.5.2 to be fitted with a radar installation. In ships of displacement 1600 t and upwards, constructed on or after 1 September 1984 the plotting facilities shall be at least as effective as a reflection plotter.

5.5.6 Automatic radar plotting aid (ARPA) (*acc. to SOLAS V/12(j)*)

5.5.6.1 Automatic radar plotting aid ARPA shall be fitted on:

- .1 ships of displacement 10 000 t and greater, constructed on or after 1 September 1984;
- .2 tankers of displacement 10 000 t and upwards, constructed before 1 September 1984;
- .3 ships of displacement 15 000 t and upwards, constructed before 1 September 1984, that are not tankers.

5.5.6.2 PRS may exempt ships from the requirements of 5.5.6.1, in cases where it considers it unreasonable or unnecessary.

5.5.7 Echo-sounding device (*acc. to SOLAS V/12(k)*)

When engaged on international voyages ships of displacement 1600 t and upwards constructed before 25 May 1980 and ships of displacement 500 t and upwards constructed on or after 25 May 1980 shall be fitted with an echo-sounding device.

5.5.8 Speed and distance measurement devices (*acc. to SOLAS V/12(l)*)

When engaged on international voyages ships of displacement 500 t and upwards constructed on or after 1 September 1984 shall be fitted with a device to indicate speed and distance. Ships required by paragraph 5.5.6.1 to be fitted with an automatic radar plotting aid shall be fitted with a device to indicate speed and distance through the water.

5.5.9 Rate-of-turn indicator (*acc. to SOLAS V/12(n)*)

Ships of displacement 100 000 and upwards constructed on or after 1 September 1984 shall be fitted with a rate-of-turn indicator.

5.5.10 Nautical publications (*acc. to SOLAS V/20*)

All ships shall carry adequate up-to-date charts, sailing directions, lists of lights, notices to mariners, tide tables and all other nautical publications necessary for intended voyage.

5.5.11 Additional equipment

PRS may allow installation of additional navigation equipment not mentioned in the present chapter provided that their arrangement and operation shall not impair operation of the basic navigation equipment.

5.6 Requirements for installation and power supply of navigational equipment**5.6.1 General**

5.6.1.1 Navigation equipment shall be installed in the wheelhouse and in a chart room (if separated).

5.6.1.2 Listed in 5.6.2.1 workstations are not obligatory, but recommended only. Their number, grade of separation or functional combination depend on the ship size and type.

5.6.1.3 Antennas, transducers, sensors and converters of navigation devices shall be installed in accordance with the guidelines of manufacturers of these devices, taking into account the requirements contained in the present sub-chapter.

5.6.2 Workstations in the wheelhouse, their arrangement and reciprocal dependence

5.6.2.1 The layout of the bridge and the distribution and arrangement of individual work stations should provide the required field of view for all functions performed on the bridge

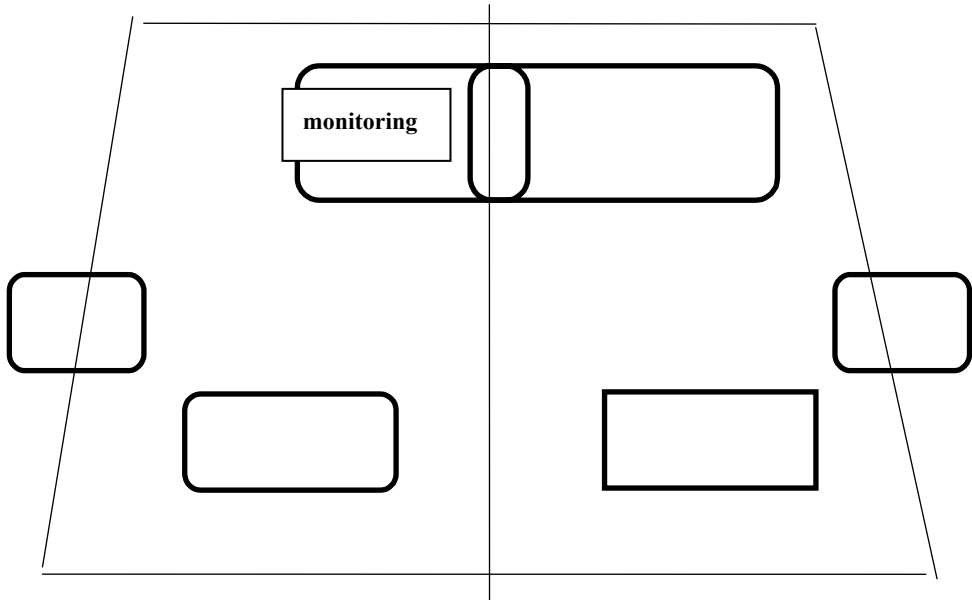

Fig. 5.6.2.1 Recommended arrangement of workstations in the navigation bridge

5.6.2.2 It is recommended that workstations are arranged in accordance with Fig. 5.6.2.1.

5.6.2.3 The main navigation and manoeuvring workstation

The workstation may be operated in both: standing and sitting position and in both cases optimum visibility shall be ensured. The workstation shall present integrated information about the parameters of motion of the ship and navigational situation around her, which is the basis for decisions to change the ship motion parameters (heading and speed), and be equipped with actuators allowing a change of these parameters.

The equipment installed at a navigation and manoeuvring workstation shall be placed sufficiently close together, so that the navigator has assured ability to operate in the bridge and obtain all necessary information enabling him to perform his tasks from a single workstation, but without limitation to a specific location.

5.6.2.4 Monitoring workstation

Monitoring workstation shall ensure information on the ship's motion and navigation situation, enabling exercising control and advisory functions by the commander of the ship and/or the pilot. From the monitoring workstation good visibility and audibility of persons being on navigation, manoeuvring and control workstations shall be ensured. The workstation may be operated in both: standing and sitting position and in both cases good visibility is required.

5.6.2.5 Manual control workstation

Manual control workstation is the workstation designated for manual control of the ship by the helmsman. It is recommended that the workstation is located in the plane of the ship's symmetry.

5.6.2.6 Bridge wings' workstations

This workstations shall provide necessary information and enable manoeuvring the ship.

5.6.2.7 Planning and documenting workstation (chart room equivalent)

This workstation shall ensure the capability to plan a route, determining the characteristics of the ship motion and documenting events in the navigation process. This workstation may be incorporated into the navigation and manoeuvring workstation.

5.6.2.8 Consoles, including the navigation table, if provided, shall be set so that the equipment which they are fitted with, are facing the person looking in the direction of the bow. This requirement also applies to a single installed devices.

5.6.3 Equipment arrangement

5.6.3.1 Each workstation shall be capable of providing basic information specific to the functions of the workstation and have the equipment required for safe performance of the navigator functions.

5.6.3.2 Equipment designated to provide visual information to more than one person on duty shall be so placed, that all users can simultaneously see it well and, if it is not possible, the devices or their indicators shall be duplicated. Certain instruments giving information for more than one workstation, if their dimensions permit, can be placed over the front windows. These are devices or indicators giving details of: the ship heading, wind, water depth, speed, rate-of-turn, rudder angle, propeller rpm, propeller pitch and time.

5.6.4 Outfit of particular workstations

5.6.4.1 The equipment shall be permanently fixed in consoles or other proper places with regard to operation and maintenance, as well as environment conditions.

5.6.4.2 PRS may accept other arrangements provided they are not worse than described.

5.6.4.3 The basic equipment necessary to perform functions of particular workstations consists of:

- .1** At the navigation and manoeuvring workstation:
 - navigation radar/ARPA indicator;
 - electronic charts indicator;
 - positioning system indicator;
 - gyro-compass repeater;
 - rate-of-turn indicator;
 - magnetic compass;
 - depth indicator;
 - speed indicator;
 - wind direction and speed indicator;
 - the main engine control and emergency stop;
 - the main engine revolutions/propeller revolutions /propeller pitch indicators;
 - propellers control;
 - steering gear control;
 - rudder angle indicator;
 - steering gear pumps change-over switch;
 - type of steering change-over switch;
 - steering station change-over switch;
 - autopilot;
 - internal communications system;
 - VHF/DSC radiotelephone;
 - acoustic signals reception system;
 - general alarm;
 - group alarms;
 - watch alarm confirmation;
 - whistle control;
 - searchlights control;
 - Morse lamp key;
 - windows' wipers, sprinklers and heaters control;
 - automatic identification system indicator/control panel;
 - sounds reception and amplification system indicator/control panel;

- .2 At the monitoring workstation:
 - navigation radar/ARPA indicator;
 - gyro-compass repeater;
 - distance and speed indicator;
 - depth indicator;
 - rate-of-turn indicator;
 - rudder angle indicator;
 - propeller revolutions/pitch indicator;
 - alarms;
 - watch alarm confirmation;
 - whistle control;
 - windows' wipers, sprinklers and heaters control;
 - VHF/DSC radiotelephone;
 - internal communications system.
- .3 At the manual steering workstation:
 - manual steering gear;
 - steering compass or master compass repeater;
 - gyro-compass repeater;
 - rudder angle indicator;
 - rate-of-turn indicator;
 - bridge wings communications;
 - windows' wipers, sprinklers and heaters control.
- .4 At the bridge wings workstations (if provided):
 - the main engine control;
 - propellers control;
 - the main engine revolutions/propeller revolutions /propeller pitch indicators;
 - rudder control;
 - steering station change-over switch;
 - rudder angle indicator;
 - gyro-compass repeater;
 - rate-of-turn indicator;
 - bottom speed indicator;
 - wind speed and direction indicator;
 - internal (communicator) and external (VHF/DSC) communications;
 - whistle control;
 - Morse lamp and searchlight control;
 - watch alarm confirmation.
- .5 At the planning and documenting workstation:
 - electronic charts indicator;
 - route planning devices;
 - chart table;
 - positioning system receiver;

- synoptic charts receiver;
- speedometer with speed and distance indication;
- echo-sounder;
- track plotter,
- radio direction-finder;
- barometer;
- chronometer;
- clock.

5.6.5 Requirements concerning particular devices

5.6.5.1 Magnetic compasses

5.6.5.1.1 The magnetic compass equipment should be installed, if practicable and reasonable, on the ship's centerline. The main lubber mark should indicate the ship's heading with an accuracy of $\pm 0.5^\circ$ (recommended $\pm 0.2^\circ$).

5.6.5.1.2 The magnetic compass shall be so located and fixed that its vertical plane passing heading marks does not deviate of more than $0,2^\circ$ from the ship's plane of symmetry, or the parallel plane.

5.6.5.1.3 The standard compass shall be installed at the bearing deck in a place, from which bearing of objects, in a possibly widest part of horizon, is ensured. In each case bearing in a sector of 230° , 115° on each side measuring from the ship's bow, shall be possible. Access to the compass from all sides shall be ensured.

5.6.5.1.4 The steering compass shall be installed in the wheelhouse by the main manual steering position.

5.6.5.1.5 Installation nearby the compass any items not provided in the agreed arrangement of these compasses may be done only with the consent of PRS.

5.6.5.1.6 The standard magnetic compass with optical transmission of indications shall be installed in accordance with the requirements of 5.6.5.1.1 ÷ 5.6.5.1.5. It shall also provide the following conditions:

- .1 the periscope screen shall be located, as far as practicable, at the level of a helmsman's eyes, at the distance of not more than 1,2 m;
- .2 The periscope tube shall not cause the dead angles of visibility for the helmsman.

5.6.5.1.7 The magnetic compasses should be installed as far as possible from magnetic material. The minimum distances of the standard compass from any magnetic material which is part of the ship's structure shall be determined according to the Fig. 5.6.5.1.7.

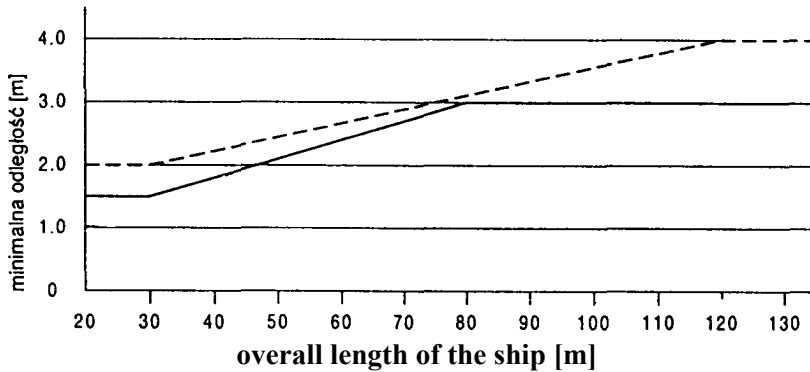

Fig. 5.6.5.1.7 Minimum desirable distance from the standard compass

- fixed magnetic material,
- - - - end parts of magnetic material, magnetic material subject to movement at sea, large masses of magnetic material with variable fields

5.6.5.2 Gyro-compasses

5.6.5.2.1 Installation of a small size gyro-compass in a wheelhouse or a chart room (if provided) is permitted.

5.6.5.2.2 The standard compass and each repeater applied for optical bearings shall be so installed that their mark lines indicating bow and stern are in the same plane as compass's rose, and parallel to the ship's plane of symmetry with accuracy $\pm 0,5^\circ$.

5.6.5.2.3 Bearing repeater shall be installed at the bearing deck in a place, from which bearing of objects, in a possibly widest part of horizon is ensured. In each case bearing in a sector of 230° , e.g. 115° on each side measuring from the ship's bow, shall be possible. Access to the repeater from all sides shall be ensured.

5.6.5.2.4 If two repeaters are installed, one on each bridge wing, than visibility of at least 180° from the bow to the relevant side shall be ensured.

5.6.5.2.5 Heading repeaters shall be provided at the main and emergency steering position or in a steering gear room (if constitutes emergency steering position function), at the navigation workstation, at the planning workstation and at the workstations on the bridge wings. If at the main steering position autopilot panel integrated with the gyro-compass repeater is provided, installation of the separate repeater is not required.

5.6.5.3 Speed and distance measuring devices

5.6.5.3.1 The main device indicating speed and distance shall be installed at the planning workstation. Speed indicators shall be provided at the navigation and the main engine control workstations (in the engine room) and, possibly, at the monitoring workstation.

5.6.5.3.2 The bottom sensor shall be installed in a such part of the hull, that at the lowest draught and during heeling of the ship will not emerge, and the flow of the water stream is not disturbed by the protruding parts of the hull and the inlet and outlet openings..

5.6.5.3.3 The bottom sensor and its stop valve shall be so installed the their damage do not result with the water ingress into the ship.

5.6.5.4 Echo-sounding equipment

5.6.5.4.1 Echo-sounder indicator shall be provided at the planning and navigation workstations and, possibly, at the monitoring workstation.

5.6.5.4.2 Echo-sounder's transducer shall be installed in the ship's bottom, in place where the lowest vibrations occur and in such a distance from sides, bow and stern that its emerging during rolling is excluded. Installation of the transducer adjacent to the ship's plane of symmetry, at the distance 0,2 to 0,5 of the ship's length (from the bow) measured in the plane of waterline corresponding to the lowest service draught.

5.6.5.4.3 The transducer shall be so installed, that its active area was parallel to the horizontal plane with the accuracy $\pm 3^\circ$.

5.6.5.4.4 The transducer shall be so installed, that its damage shall not result with the water ingress into the ship. If not installed in a special watertight compartment, the transducer's cable shall be led from the transducer to the bulkhead deck through metal pipe retaining tightness and continuity of electrical conductivity.

5.6.5.4.5 It shall be noted that near the transducer were neither protruding parts of the hull, nor inlet and outlet openings which may cause aeration of the flowing water streams, interfering in this way the work of echo-sounder.

5.6.5.4.6 Adjacent to the transducer shall not be other sources of ultrasonic radiation, operating at the same time as echo-sounder.

5.6.5.5 Rate-of-turn indicator

5.6.5.5.1 Installation of a small size rate-of-turn indicators in a wheelhouse or a chart room (if provided) is permitted.

5.6.5.5.2 Rate-of-turn repeaters shall be installed at the main manual steering workstation, at the navigation workstation and at the bridge wings.

5.6.5.6 Radars

5.6.5.6.1 The main radar indicator shall be installed at the navigation and maneuvering workstation, adjacent to the front wall, at the right side. It is recommended that auxiliary indicator or the indicator of the second radar is installed at the monitoring workstation.

5.6.5.6.2 The radar antenna shall be installed on the mast, as high as practicable, and so, that in the range of heading angles from 5° on the left side to 5° to the right side were no dead observation sectors, and the crew was not exposed to the micro-waves radiation, and the antenna was not exposed to exhaust gases of the main engine flowing from the funnel.

5.6.5.6.3 When two radars are installed, their antennas shall be fixed at different heights so, that mutual interference or the receivers damage is impossible.

5.6.5.6.4 When two radars are installed, in order to improve utilization of the whole radar installation and increase the reliability, the switch-over device may be used. The device shall be designed so that any damage to the radar will not impair the characteristics or deprive power supply to the other of them

5.6.5.7 Automatic radar plotting device (ARPA)/ automatic tracking aid (ATA)/ electronic plotting aid (EPA)

5.6.5.7.1 The device may be an independent structure, co-operating with any radar or be an integral part of the radar. If it is part of the radar, it shall be placed in accordance with 5.6.5.6.1. If the device is an independent, co-operating with radar, it shall be installed in the wheelhouse, at the navigation and ship manoeuvring workstation in the vicinity of the main radar.

5.6.5.7.2 For antenna installation requirements of 5.6.5.6.2÷5.6.5.6.4 apply.

5.6.5.7.3 The device shall be installed so, that its display can be observed simultaneously by two persons.

5.6.5.8 Electronic chart display and information system indicators (ECDIS)

Electronic charts indicators shall be installed at the planning and documenting workstation and/or navigation and manoeuvring workstation.

5.6.5.9 Sounds reception and amplification system

5.6.5.9.1 Microphones shall be mounted far away from noise sources in such a way that the noise caused by wind and mechanical vibration is reduced.

5.6.5.9.2 The indicators shall be visible from the navigation and manoeuvring workstation.

5.6.5.9.3 The loudspeaker(s) shall be so installed that reproduced signals are audible at the whole bridge.

5.6.5.10 Radionavigation system receivers

5.6.5.10.1 Radionavigation system receivers shall be installed at the planning workstation, and their repeaters at the navigation and manoeuvring workstation.

5.6.5.10.2 It is recommended that radionavigation system receivers' antennas are installed as high as practicable above the bearing deck. Installation of the antennas underneath any type of horizontally led structures, rigging, etc.

5.6.5.10.3 Radionavigation receiver antennas shall not be installed in the field of view of the main beam (within $\pm 20^\circ$) of radar antennas.

5.6.5.11 Automatic identification system (AIS)

5.6.5.11.1 Automatic identification system indicator/panel shall be installed at the navigation and manoeuvring workstation.

5.6.5.11.2 VHF antenna of the AIS system shall be located as high as possible, and so, that in the way of electromagnetic waves propagation, as far as practicable, there were no obstacles over all horizon.

5.6.5.11.3 VHF antennas shall be located at the distance of more than 1 m from the parallel conductive structures.

5.6.5.11.4 If the VHF antenna of AIS system is located at the same height as the VHF/DSC watch receiver antenna, than distance between them shall be at least 5 m.

5.6.5.11.5 If the AIS system is provided with the GPS receiver antenna, than that antenna shall be installed in accordance with 5.6.5.10.2 to 5.6.5.10.3.

5.6.5.12 Voyage data recorders (VDR)

5.6.5.12.1 It is recommended that block for data acquisition is installed in the wheelhouse or its vicinity so, that the cables transmitting data from the co-operating devices are of the smallest length.

5.6.5.12.2 Block for data storage shall be installed on the wheelhouse roof. In the case of float-free design, the block shall be installed so, that there are not mechanical obstacles preventing the block from free detachment from the ship.

5.6.6 Navigational equipment power supply

5.6.6.1 The requirement of power supply to the navigational equipment from the main and emergency sources of energy applies to ships constructed on or after 1 July 1986 (*acc. to SOLAS II-1/42.2.3.2*).

5.6.6.2 All equipment (except for gyro-compasses) shall be supplied from separate circuits of the navigational equipment switchboard. Supply of those devices from the wheelhouse control-steering console is permitted.

5.6.6.3 The navigational equipment switchboard shall be supplied from the main and emergency source of energy with the independent circuits. Cables of the circuits shall be led on different routes, possibly maximum apart from each other, both vertically and horizontally. Prompt switch-over of the sources of supply shall be ensured.

5.6.6.4 Gyro-compasses shall be supplied from the main and emergency source of energy with the independent circuits. Cables of the circuits shall be led on different routes, possibly maximum apart from each other, both vertically and horizontally. Automatic switch-over of the sources of supply shall be ensured.

5.6.6.5 In the case of the existing ships PRS may accept power supply of the navigational equipment from the emergency source of energy with one cable only.

5.6.6.6 If the GPS receiver is applied for automatic transmission of the ship's position data to the Global Maritime Distress and Safety System devices (GMDSS), than it shall be additionally supplied from the reserve radio accumulators battery or from uninterrupted power supply means (UPS). Switch-over to supply from reserve accumulator battery shall be automatic.

5.6.6.7 The single ship of 5,000 t displacement may be granted by PRS a partial or conditional exemption from the requirement 5.6.6.1, if the ship undertakes such voyages, that the largest distance between the ship and the shore, nature of the voyage, lack of significant navigational obstacles to, and other conditions affecting the safety make the full application of requirements of 5.6.6.1 groundless or not necessary (*acc. to SOLAS II-1/42.2.3.2*).

5.6.7 Cable network installation

5.6.7.1 Entire cable network belonging in the ship to the navigational equipment shall be made of screened cables and in accordance with the requirements of *Part VIII – Electrical Installations and Control Systems*.

5.6.7.2 Insulation resistance of any laid cable, disconnected on both sides, shall be at least 20 MΩ, irrespective of its length.

5.6.7.3 Cables of the echo-sounders' transducers and speedometers in compartments located below the bulkhead deck shall be led through metal pipes maintaining their tightness and continuity of electrical conductivity.

5.6.7.4 Cables of antennas circuits, as well as cables of echo-sounders' transducers shall be led separately from the cables of another designation. If the latter is not possible than double screened cables shall be applied.

5.6.7.5 Internal bend radius of the special cables (e.g. wave-guide) shall not be less than the required by the manufacturer.

5.6.8 Navigational equipment earthing

5.6.8.1 The navigational equipment shall have, led by the shortest route, protective and high frequency operational earthing.

5.6.8.2 Operational earthing of the navigational equipment shall be made of a copper band of a flexible wire of the cross section area at least 6 mm².

5.6.8.3 The cables' screening and metal armouring in places of their inlet to the equipment shall be earthed, unless the manufacturer evidently prohibits such solution.

5.6.8.4 Places of earthing shall be accessible for periodical measurements and maintenance.

5.6.8.5 General resistance of all electrical connections of any earthing shall not exceed 0,02 Ω .

5.7 Technical-operational requirements for navigational equipment

5.7.1 General (*acc. to Res. A.694(17)*)

5.7.1.1 Navigational equipment installed in ships engaged on the international voyages shall comply with the requirements of sub-chapter 5.7, as well as the requirements for particular equipment, included in the other parts of chapter 5.

5.7.1.2 Navigational equipment installed in ships not engaged on the international voyages may be, upon PRS consideration, exempted from the obligation of the full compliance with the technical-operational requirements for the particular equipment contained in the sub-chapter 5.7.

5.7.1.3 Where a set of multiple devices allows the implementation of additional functions in relation to the minimum requirements set out in Chapter 5, the use of these additional features, as well as damage to any of these devices, shall not impair the operation of the basic equipment.

5.7.2 Controls

5.7.2.1 The number of operational controls, their design and manner of function, location, arrangement and size shall provide for simple, quick and effective operation. The controls shall be arranged in a manner which minimizes the chance of inadvertent operation.

5.7.2.2 All operational controls shall permit normal adjustments to be easily performed and shall be easy to identify from the position at which the equipment is normally operated. Controls not required for normal operation shall not be readily accessible.

5.7.2.3 Adequate illumination shall be provided in the equipment or in the ship to enable identification of controls and facilitate reading of indicators at all times. Means shall be provided for dimming the output of any equipment light source which is capable of interfering with navigation.

5.7.2.4 The design of the equipment shall be such that misuse of the controls shall not cause damage to the equipment or injury to personnel.

5.7.2.5 Where a digital input panel with the digits 0 to 9 is provided, the digits shall be arranged to conform with relevant *CCITT E161/QII* recommendations. However, where an alphanumeric keyboard layout, as used on office machinery and data processing equipment, is provided, the digits 0 to 9 may, alternatively, be arranged to conform with the *ISO 3791* standard.

5.7.3 Equipment resistance to power supply sources' parameters variations

Change of the power sources parameters normally encountered on the ship, as set out in *IEC Publication 945* and *Part VIII – Electrical installations and control systems*, shall not affect the normal operation of the devices.

5.7.3.1 Means shall be incorporated for the protection of equipment from the effects of excessive current and voltage, transients and accidental reversal of the power supply polarity.

5.7.3.2 If provision is made for operating equipment from more than one source of electrical energy, arrangements for rapidly changing from one source to the other shall be provided.

5.7.4 Durability and resistance of the equipment to external exposures

5.7.4.1 Equipment shall be capable of continuous operation under the conditions of various sea states, ship's motion, vibration, humidity and temperature likely to be experienced in ships.

5.7.4.2 The equipment shall comply with the conditions for environmental resistance presented in *IEC Publication 945*.

5.7.5 Resistance of the equipment to interference

5.7.5.1 All reasonable and practicable steps shall be taken to ensure electromagnetic compatibility between the equipment concerned and other radiocommunication and navigational equipment carried on board in compliance with the relevant requirements of *IEC Publications 533* and *945 (acc. to Res. A.813(19))*.

5.7.5.2 Adequate design solutions, ensuring the equipment resistance to electrical and magnetic interference described in *IEC Publication 945* shall be provided.

5.7.5.3 Mechanical noise from all units shall be limited so as not to prejudice the hearing of sounds on which the safety of the ship might depend.

5.7.5.4 Each unit of equipment normally to be installed in the vicinity of a standard compass or a magnetic steering compass shall be clearly marked with the minimum safe distance at which it may be mounted from such compasses.

5.7.6 Means of safety

5.7.6.1 As far as is practicable, accidental access to dangerous voltages shall be prevented. All parts and wiring in which the direct or alternating voltages or both (other than radio frequency voltages) combine to give a peak voltage greater than 55 V shall be protected against accidental access and shall be isolated automatically from all sources of electrical energy when the protective covers are removed. Alternatively, the equipment shall be so constructed that access to such voltages may only be gained after having used a tool for this purpose. Warning labels shall be prominently displayed both within the equipment and on protective covers.

5.7.6.2 Means shall be provided for earthing the equipment covers. However this shall not cause any terminal of the source of electrical energy to be earthed.

5.7.6.3 All steps shall be taken to ensure that electromagnetic radio frequency energy radiated from the equipment shall not be a hazard to personnel..

5.7.6.4 Equipment containing elements such as vacuum tubes which are likely to cause X-radiation shall comply with the following requirement:

- .1 external X-radiation from the equipment in its normal working condition shall not exceed 2 W/m^2 , unless another maximum values are applicable on the ship;
- .2 when X-radiation can be generated inside the equipment above the levels of 10 W/m^2 to 100 W/m^2 , a prominent warning shall be fixed inside the equipment and the precautions to be taken when working on the equipment shall be included in the equipment manual, unless another margin values are applicable on the ship;
- .3 if malfunction of any part of the equipment can cause an increase in X-radiation, adequate advice shall be included in the information about the equipment, warning of the circumstances which could cause the increase and stating the precautions which shall be taken.

5.7.7 Maintenance

5.7.7.1 The equipment shall be so designed that the main units can be replaced readily, without elaborate recalibration or readjustment.

5.7.7.2 Equipment shall be so constructed and installed that it is readily accessible for inspection and maintenance purposes.

5.7.7.3 Adequate information shall be provided to enable the equipment to be properly operated and maintained. The information shall:

- .1 in the case of equipment so designed that fault diagnosis and repair down to component level are practicable, provide full circuit diagrams, component layouts and a component parts list; and

- .2 in the case of equipment containing complex modules in which fault diagnosis and repair down to component level are not practicable, contain sufficient information to enable a defective complex module to be located, identified and replaced.

5.7.8 Marking and identification

5.7.8.1 Each unit of the equipment shall be marked externally with the following information which shall be clearly visible in the normal installation position:

- .1 **identification of the manufacturer;**
- .2 equipment type number or model identification under which it was type tested; and
- .3 serial number of the unit.

5.7.9 Magnetic compasses (*acc. to Res. A.382(X)*)

5.7.9.1 Accuracy of the compass indications

The magnetic compasses shall ensure indications of the ship's heading with the accuracy:

- ± 10 in motion, without rolling;
- ± 50 with rolling in all directions up to $\pm 22,50$, with period of 6 to 15 seconds.

5.7.9.2 Compass Card

5.7.9.2.1 The compass card shall be graduated in 360 single degrees. A numerical indication shall be provided every ten degrees, starting from North (000°) clockwise to 360° . The cardinal points shall be indicated by the capital letters N, E, S and W. The North point may instead be indicated by a suitable emblem.

5.7.9.2.2 The directional error of the card, composed of inaccuracies in graduation, eccentricity of the card on its pivot and inaccuracy of orientation of the card on the magnetic system shall not exceed 0.5° on any heading..

5.7.9.2.3 The card of the steering compass shall clearly be readable both in daylight and artificial light at a distance of 1.4 m.

5.7.9.3 Design error of the compass indications

5.7.9.3.1 With the compass rotating at a uniform speed of 1.5° per second and a temperature of the compass of $20^\circ\text{C} \pm 3^\circ\text{C}$ the deflection of the card shall not exceed $(36/H)^\circ$, if the diameter of the card is less than 200 mm. If the diameter of the compass card is 200 mm or more, the deflection of the card shall not exceed $(54/H)^\circ$, where H is the horizontal component of the magnetic flux density in μT (micro Tesla) at the place of the compass.

5.7.9.3.2 The error due to friction shall not exceed $(3/H)^\circ$ at a temperature of $20^\circ\text{C} \pm 3^\circ\text{C}$.

5.7.9.3.3 With a horizontal component of the magnetic field of $18 \mu\text{T}$ the half period of the card shall be at least 12 seconds, after an initial deflection of 40° . The time taken to return finally to within $\pm 1^\circ$ of the magnetic meridian shall not exceed 60 seconds after an initial deflection of 90° . Aperiodic compasses shall comply with the latter requirements only.

5.7.9.4 Correcting Devices

5.7.9.4.1 The binnacle shall be provided with devices for correcting semicircular and quadrantal deviation due to:

- the horizontal components of the ship's permanent magnetism;
- heeling error;
- the horizontal component of the induced horizontal magnetism;
- the horizontal component of the induced vertical magnetism.

5.7.9.4.2 The correcting devices provided in sub-paragraph 5.7.9.4.1 shall ensure that no serious changes of deviation occur under the influence of the conditions described in paragraph 4 and particularly considerable alteration of magnetic latitude. Sextantal and deviations of higher order shall be negligible.

5.7.9.5 Materials

5.7.9.5.1 The magnets used in the directional system and the corrector magnets for correcting the permanent magnetic fields of the ship shall have a high coercivity of at least 11.2 kA/m .

5.7.9.5.2 Material used for correcting induced fields shall have a low remanence and coercivity.

5.7.9.5.3 All other materials used in the magnetic compass and in the binnacle shall be non-magnetic, so far as reasonable and practicable and such that the deviation of the card caused by these materials shall not exceed $(9/H)^\circ$.

5.7.9.6 Construction

5.7.9.6.1 Primary and emergency illumination shall be installed so that the card may be read at all times.

5.7.9.6.2 In the case where an electrical reproduction of the indication of the standard compass is regarded as a steering compass, the transmitting system shall be provided with both primary and emergency electrical power supply.

5.7.9.6.3 The standard compass shall be suspended in gimbals so that its verge ring remains horizontal when the binnacle is tilted up to 40° in any direction, and so that the compass cannot be dislodged under any condition of sea or weather.

5.7.9.6.4 Steering compasses suspended in gimbals shall meet the same requirements. If they are not suspended in gimbals they shall have a freedom of the card of at least 30° in all directions.

5.7.9.6.5 The height of the standard compass base, together with the foundation cushion, shall be such that the plane of the compass bowl glass was on at least 1,300 mm from the deck, but shall not exceed the height ensuring comfortable use of the compass.

5.7.9.6.6 The standard compass shall be provided with the direction-finder ensuring bearing of the visible from the ship objects and heavenly bodies with the accuracy of reading up to $\pm 0,25^\circ$.

5.7.9.7 Magnetic compasses with the remote electrical indications transmission

5.7.9.7.1 Magnetic compasses with the remote electrical indications transmission shall comply with the requirements of 5.7.9.1 to 5.7.9.6 and ensure heading indications on repeaters with accuracy defined in 5.7.9.6.

5.7.9.7.2 As the control system for remote electrical transmission of indications may be applied magnets of the standard compass or special magnetic control system.

5.7.9.7.3 In the case described in w 5.7.9.7.2 device for electrical transmission of indications to the repeaters shall be so designed that its location and operation does not prevent bearing, taking readings of heading and bearings from the compass rose, and in deviation compensation.

5.7.9.7.4 Special control system of the remote electrical transmission of indications system shall be provided with the device for deviation compensation.

5.7.9.7.5 The transmitter and the entire remote electrical transmission of indications system shall be capable to operate under following changes in the ship motion:

- .1 rate-of-turn up to $6^\circ/\text{s}$;
- .2 yawing with the period of $10\div 20$ s and the greatest heading deviation of $\pm 5^\circ$.

5.7.9.7.6 Difference between indications of repeaters and the control system of the magnetic compass with the remote electrical transmission of indications shall not exceed 1° .

5.7.9.7.7 Damage or switching off of particular repeaters shall not have influence on accuracy of the remaining repeaters and the main compass.

5.7.9.7.8 Audible signalling informing on follow-up system damage of each magnetic compass with the remote electrical transmission of indications system shall be provided. Signalling shall be supplied from the independent source.

5.7.9.7.9 In the set of magnetic compass with the remote electrical transmission of indications system lighting panel with the inscription "Repeaters connected to the magnetic compass".

5.7.9.8 Magnetic compasses with the remote optical transmission of indications

5.7.9.8.1 The design of a magnetic compass with remote optical transmission of indications shall provide on the screen a direct picture of the compass rose's sector with graduated scales clearly visible on the arc of not less than 30 degrees, and heading mark fastened in the compass bowl body. It is recommended that the device allows to obtain an image of the rose scale from the fore and aft side of the periscope.

5.7.9.8.2 The length of the magnetic compass with optical remote transmission of indications periscope shall be such that, setting the compass on the basis, including the periscope tube passage through the deck, the screen can be installed at the level of helmsman eyes. It shall be possible to control the screen height of 100 ÷ 150 mm upwards and downwards from the middle position.

5.7.9.8.3 The screen shall be provided with the device protecting from the bright daylight and artificial light which may result with illumination of the compass rose display on the screen. The display shall be easily readable by day and by night.

5.7.9.8.4 The design of the optical system and the screen shall provide clear and bright visibility of the compass rose sector during bearing, with the compass helmet closed.

5.7.9.8.5 A device for adjusting and positioning the screen to facilitate the indications reading shall be provided.

5.7.9.8.6 The screen casing shall be hose-tight – grade of protection IP56 acc. to *IEC529 Publication*.

5.7.9.9 Boats' magnetic compasses

5.7.9.9.1 The compass rose graduation shall be at 1°, 2° or more, depending on the rose diameter, but in no case shall be greater than 5°.

5.7.9.9.2 The error of the compass rose indications at the ambient temperature within $20^{\circ} \pm 3^{\circ}\text{C}$ for the horizontal component H of the magnetic flux density at the place of the compass installation shall not exceed $(9/H)^{\circ}$.

5.7.9.9.3 Compass scale lighting shall be autonomous or illuminated by appropriate means.

5.7.9.9.4 The compass shall be provided with the device for fastening in a boat and with a casing for its storage.

5.7.9.9.5 The compass rose's diameter shall provide easy reading of indications.

5.7.10 Gyro-compasses (*acc. to Res. A.424(XI)*)

5.7.10.1 Method of presentation

The compass card shall be graduated in equal intervals of one degree or a fraction thereof. A numerical indication shall be provided at least at every ten degrees, starting from 000° clockwise through 360°.

5.7.10.2 Illumination

Fully adequate illumination shall be provided to enable reading of scales at all times. Facilities for dimming shall be provided.

5.7.10.3 Accuracy of indications

5.7.10.3.1 When switched on in accordance with the manufacturer's instructions the compass shall settle within six hours in latitudes of up to 60°. The compass is settled where three readings taken at 20 minutes intervals do not exceed 0,7°. This applies to the case where the gyro-compass is settled on the horizontal fixed base.

5.7.10.3.2 The settle point error as defined in paragraph 2.5 at any heading and at any latitude up to 60° shall not exceed $\pm 0.75 \times \secant \text{ latitude}$ where heading indications of the compass shall be taken as the mean of 10 readings at 20 minute intervals, and the root mean square value of the differences between individual heading indications and the mean shall be less than $0.25^\circ \times \secant \text{ latitude}$.

5.7.10.3.3 When switched on in accordance with the manufacturer's instructions, the compass shall settle within six hours in latitudes of up to 60° when rolling and pitching with simple harmonic motion of any period between six and fifteen seconds, a maximum angle of 5°, and a maximum horizontal acceleration of 0.22 m/s².

5.7.10.3.4 The repeatability of the settle point error of the master compass shall be within $\pm 1^\circ \times \secant \text{ latitude}$ under the general conditions of power supply and the resistance to effects of climate, including variations in magnetic field likely to be experienced in the ship in which it is installed.

5.7.10.3.5 In latitudes of up to 60°:

- .1** the residual steady state error, after correction for speed and course influences at a speed of twenty knots, shall not exceed $\pm 0.25 \times \secant \text{ latitude}$;
- .2** the error due to a rapid alteration of speed of twenty knots shall not exceed $\pm 2^\circ$;
- .3** the error due to a rapid alteration of course of 180° at a speed of twenty knots shall not exceed $\pm 3^\circ$;
- .4** the transient and steady state errors due to the ship rolling, pitching and yawing, with simple harmonic motion of any period between six and fifteen seconds, maximum angle of 20°, 10° and 5° respectively, and maximum horizontal acceleration not exceeding 1 m/s², shall not exceed $1^\circ \times \secant \text{ latitude}$.

5.7.10.3.6 The maximum divergence in reading between the master compass and repeaters under all operational conditions shall not exceed $\pm 0.5^\circ$.

5.7.10.4 Additional requirements

5.7.10.4.1 Means shall be provided for correcting the errors induced by speed and latitude.

5.7.10.4.2 An automatic alarm shall be provided to indicate a major fault in the compass system.

5.7.10.4.3 The system shall be designed to enable heading information to be provided to other navigational aids such as radar, radio direction-finder and automatic pilot.

5.7.11 Devices for indication speed and distance (*acc. to Res. A.824(19), Res. MSC.96(72)*)

5.7.11.1 Introduction

5.7.11.1.1 Devices for indication the speed and distance are intended for providing information on the distance run and the forward speed of the ship through the water or over the ground. Additionally, information on ship's motions other than in the forward axis may be provided. In the case of indication the forward speed through the water, the equipment shall operate properly at forward speeds up to the maximum speed of the ship and in water of depth greater than 3 m beneath the keel. In the case of indication the speed over the ground, the equipment shall operate properly at forward speed in waters of depth greater than 2 m beneath the keel.

5.7.11.1.2 The device for indication the speed and distance, co-operating with the radar plotting device and/or track control equipment shall provide speed through the water in the fore and aft direction.

5.7.11.2 Methods of presentation

5.7.11.2.1 Speed information may be presented in either analogue or digital form. Where a digital display is used, its incremental steps shall not exceed 0.1 knots. Analogue displays shall be graduated at least every 0.5 knots and be marked with figures at least every 5 knots. If the display can present the speed of the ship in other than the forward direction, the direction of movement shall be indicated unambiguously.

5.7.11.2.2 Distance run information shall be presented in digital form. The display shall cover the range from 0 to not less than 999.9 nautical miles and the incremental steps shall not exceed 0.1 nautical miles. Where practicable, means shall be provided for resetting a readout to zero.

5.7.11.2.3 The display shall be easily readable by day and by night.

5.7.11.2.4 Means shall be provided for feeding distance run information to other equipment fitted on board. In this regard:

- .1 information on speed, distance and direction shall be transmitted in accordance with the international requirements for interfaces designated for marine equipment, described in *IEC Publication 61162*;
- .2 additionally during speed measurement in forward direction impulsing may be applied. In such case one impulse shall correspond to the distance of 0,005 Nm.

5.7.11.2.5 If equipment is capable of being operated in either the "speed through the water" or "speed over the ground" mode, mode selection and mode indication shall be provided.

5.7.11.2.6 If the equipment has provision for indicating speeds other than on a single fore and aft axis, then the forward and athwart speed through the water must be provided, and the forward and athwart speed over the ground may be provided as an additional option. Resultant speed and course information may be provided as a switchable option. All such information shall clearly indicate the direction, mode and validity status of the displayed information.

5.7.11.3 Accuracy of measurement

5.7.11.3.1 Errors in the indicated speed, when the ship is operating free from shallow water effect and from the effects of wind, current and tide, shall not exceed:

- .1 for digital display – 2% of the speed of the ship, or 0.2 knots, whichever is greater;
- .2 for analogue display – 2,5% of the speed of the ship, or 0.25 knots, whichever is greater; and
- .3 for data output transmission– 2% of the speed of the ship, or 0.2 knots, whichever is greater.

5.7.11.3.2 Errors in the indicated distance run, when the ship is operating free from shallow water effect and from the effects of wind, current and tide, shall not exceed 2% of the distance run by the ship in 1 h or 0.2 nautical miles in each hour, whichever is greater

5.7.11.3.3 If the accuracy of devices to indicate speed and distance run can be affected by certain conditions (e.g. sea state and its effects, water temperature, salinity, sound velocity in water, depth of water under the keel, heel and trim of ship), details of possible effects shall be included in the equipment handbook.

5.7.11.3.4 The performance of the equipment shall be such that it will meet the requirements of these standards when the ship is rolling up to $\pm 10^\circ$ and pitching up to $\pm 5^\circ$.

5.7.11.4 Construction and installation

5.7.11.4.1 The system shall be so designed that neither the method of attachment of parts of the equipment to the ship nor damage occurring to any part of the equipment which penetrates the hull could result in the ingress of water to the ship.

5.7.11.4.2 Where any part of the system is designed to extend from and retract into the hull of the ship, the design shall ensure that it can be extended, operated normally and retracted at all speeds up to the maximum speed of the ship. Its extended and retracted positions shall be clearly indicated at the display position.

5.7.12 Echo-sounding equipment (*acc. to Res.A.224(VII), Res. MSC.74(69)*)

5.7.12.1 Range and scales of depth measurement

5.7.12.1.1 Under normal propagation conditions the equipment shall be capable of measuring any clearance under the transducer between 2 meters and 200 meters.

5.7.12.1.2 The equipment shall provide a minimum of two range scales one of which, the deep range, shall cover the whole range of depth (200 m), and the other, the shallow range, one tenth thereof (20 m).

5.7.12.1.3 The scale of display shall not be smaller than:

- 0,5 mm per meter depth on the deep range scale; and
- 5 mm per meter depth on the shallow range scale

5.7.12.2 Method of presentation

5.7.12.2.1 The primary presentation shall be a suitable graphical display which provides the immediate depth and a visible record of soundings. The displayed record shall, show at least 15 min of soundings.

5.7.12.2.2 Other forms of display may be added but these shall not affect the normal operation of the main display.

5.7.12.2.3 Wskaźnik graficzny powinien zapewniać obrazowanie znaczników głębokości w przedziałach nie większych niż 1/10 aktualnie wykorzystywanego zakresu oraz znaczników czasu w przedziałach nie przekraczających 5 min.

5.7.12.2.4 It shall be possible to record on paper recording or other means the information about the depth(s) and the associated time for 12 h.

5.7.12.2.5 If paper is used for recording either by marks on the recording paper, or by other means, there shall be a clear indication when the paper remaining is less than 1 m.

5.7.12.3 Accuracy of measurement

Based on a sound speed in water of 1,500 m/s, the tolerance of the indicated depth shall be either:

- ± 5 m or $\pm 2,5\%$ of the indicated depth, whichever is greater, on the range of 200 m;
- $\pm 0,5$ m or $\pm 2,5\%$ of the indicated depth, whichever is greater, on the range of 20 m.

5.7.12.4 Design requirements

5.7.12.4.1 The equipment shall maintain its required parameters under the ship's speed from 0 to 30 knots.

5.7.12.4.2 The performance of the equipment shall be such that it will meet the requirements when the ship is rolling $\pm 10^\circ$ and/or pitching $\pm 5^\circ$.

5.7.12.4.3 The pulse repetition rate shall be not slower than 12 pulses per minute on the deep range, and 36/min on the shallow range.

5.7.12.4.4 The function of range scale selection shall be directly accessible. The settings for the range scale and preset depth alarm shall be recognizable in all light conditions

5.7.12.4.5 An alarm signal - both visual and audible with mute function - shall be provided when the water depth is below a preset value.

5.7.12.4.6 Alarm signals, both visual and audible (with mute function) to the navigator on the watch shall be provided to indicate failure or a reduction in the power supply to the echo-sounder which would affect the safe operation of the equipment.

5.7.12.4.7 Application of more than one transducer and transceiver block is permitted. In the case of application additional transducers independent display of the depth and clear information on which of the transducers is being used, shall be provided.

5.7.12.4.8 Output(s) shall be available from which depth information may be supplied to other equipment such as remote digital displays, voyage data recorder and a track control system. These outputs shall be digital, serial communication, facilities which shall comply with the requirements of *IEC Publication 1162*.

5.7.13 Rate-of-turn indicator (ROTI) (*acc. to Res. A.526(13)*)

5.7.13.1 Introduction

The ROTI may be self-contained; alternatively it may form part of, or derive information from, any other appropriate equipment.

5.7.13.2 Methods of ROTI presentation

5.7.13.2.1 The indication required shall be provided by a centre-zero analogue type indicator (preferably circular). Where a circular scale indicator is used, the zero shall be uppermost.

5.7.13.2.2 A turn of ship to port shall be indicated on the left of the zero point and a starboard turn to the right of the zero point. If the actual rate of turn exceeds full scale deflection, this shall be clearly indicated on the display.

5.7.13.2.3 In addition, an alphanumeric display may be provided. Positive indication of port and starboard shall be provided on such displays.

5.7.13.2.4 The length of scale in either direction from zero shall not be less than 120 mm. The sensitivity of the system shall ensure that a change in the rate of turn of 1° per minute is represented by a distance of not less than 4 mm on its scale.

5.7.13.2.5 A linear range scale of not less than $\pm 30^\circ$ per minute shall be provided. This scale shall be marked in intervals of 1° per minute on both sides of zero. The scale shall be marked with figures every 10° per minute. Every 10° mark shall be significantly longer than the 5° mark which in turn shall be significantly longer than the 1° mark. The marks and figures shall preferably be red or a light colour on a dark background.

5.7.13.2.6 Additional linear range scales may be provided.

5.7.13.2.7 Damping of the ROTI shall be provided with a time constant which may be varied during operation in the range zero to at least 10 seconds.

5.7.13.3 Accuracy

5.7.13.3.1 The indicated rate of turn shall not deviate from the actual rate of turn of the ship by more than 0.5° per minute plus 5% of the indicated rate of turn of the ship. These values include the influence of earth rate.

5.7.13.3.2 Periodic rolling motion of the ship with an amplitude of $\pm 5^\circ$ and period of up to 25 seconds and periodic pitching motion with an amplitude of $\pm 1^\circ$ and period of up to 20 seconds shall not change the mean value of the indicated rate of turn by more than 0.5° per minute.

5.7.13.3.3 The ROTI shall meet these accuracy requirements at all ship speeds up to 10 knots.

5.7.13.4 Design requirements

5.7.13.4.1 The ROTI shall be ready for operation and comply with these standards within 4 minutes of being switched on.

5.7.13.4.2 The design shall be such that whether operating or not the ROTI will not degrade the performance of any other equipment to which it is connected.

5.7.13.4.3 The ROTI shall include a means of enabling the operator to verify that it is operating.

5.7.14 Radars (acc. to Res. A.477(XII), Res. MSC.64(67) Annex 4)**5.7.14.1 Introduction**

The radar equipment shall provide an indication, in relation to the ship, of the position of other surface craft and obstructions and of buoys, shorelines and navigational marks in a manner which will assist in navigation and in avoiding collision.

5.7.14.2 Range of performance

5.7.14.2.1 The operational requirement under normal propagation conditions, when the radar antenna is mounted at a height of 15 meters above sea level, is that the equipment shall in the absence of clutter give a clear indication of:

.1 coastlines:

- at 20 nautical miles when the ground rises to 60 meters;
- at 7 nautical miles when the ground rises to 6 meters.;

.2 surface objects:

- at 7 nautical miles a ship of 5,000 tons gross tonnage, whatever her aspect;
- at 3 nautical miles a small vessel of 10 meters in length;
- at 2 nautical miles an object such as a navigational buoy having an effective echoing area of approximately 10 m².

5.7.14.2.2 The surface objects specified in 5.7.14.2.1.2 shall be clearly displayed from a minimum range of 50 meters up to a range of one nautical mile, without changing the setting of controls other than the range selector.

5.7.14.3 Display

5.7.14.3.1 The equipment shall without external magnification provide a relative plan display in the head-up non-stabilized mode with an effective diameter of not less than:

- .1** 180 millimetres on ships of 300 tons gross tonnage and more but less than 1,000 tons gross tonnage;
- .2** 250 millimetres on ships of 1,000 tons gross tonnage and more but less than 10,000 tons gross tonnage;
- .3** 340 millimetres on ships of 10,000 tons gross tonnage and upwards.

5.7.14.3.2 The equipment shall provide the following sets of range scales of display: 0,25; 0,5; 0,75; 1,5; 3; 6; 12; 24 nautical miles.

5.7.14.3.3 Additional range scales may be provided.

5.7.14.3.4 The range scale displayed and the distance between range rings shall be clearly indicated at all times.

5.7.14.3.5 Within the effective display radar video area, the display shall only contain information which pertains to the use of the radar display for navigation or collision avoidance and which has to be displayed there because of its association with a target (e.g. target identifiers, vectors) or because of some other direct relationship with the radar display.

5.7.14.3.6 The origin of the range scale (radar video) shall start at own ship, be linear and shall not be delayed.

5.7.14.3.7 Multi-colour displays are permitted but the following requirements shall be met:

- .1 target echoes shall be displayed by means of the same basic colours and the echo strength shall not be displayed in different colours; and
- .2 additional information may be shown in different colours.

5.7.14.3.8 The radar picture and information shall be readable under all ambient light conditions. If a light shield is necessary to facilitate operation of the display in high ambient light levels, then means shall be provided for its ready attachment and removal.

5.7.14.3.9 Selected parts of the System Electronic Navigation Chart (SENC) information may be displayed in such a way that the radar information is not masked, obscured or degraded. If SENC information is made available for a radar display it shall at least include coastlines, own ship's safety contour, dangers to navigation and fixed and floating aids to navigation. The mariner shall be able to select those parts of the SENC, which can be made available and the mariner requires to be displayed.

5.7.14.3.10 For the superimposition of selected parts of the SENC and radar display:

- .1 to ensure that the information displayed is correlated and in the same reference and co-ordinate system;
- .2 the whole effective display area shall contain the available radar and SENC information;
- .3 in case of any deviations between the chart image and the radar image through detectable causes, manual adjustment shall be possible. Any manual adjustment shall be clearly indicated as long as it is activated. Resetting shall be possible in a simple manner;
- .4 the display of radar information shall have priority;
- .5 The equipment shall be capable of appropriately stabilizing the radar image, ARPA vectors and SENC information. The operating mode shall be clearly indicated; and
- .6 independence of radar/ARPA and SENC:
 - the SENC information shall not have an adverse effect on the radar picture;
 - radar/ARPA information and SENC information shall be clearly recognizable as such; and
 - in the case of a malfunction of one component, the function of the other component shall not be affected.

5.7.14.3.11 The frequency band in use shall be indicated to the operator.

5.7.14.4 Range measurement

5.7.14.4.1 Electronic fixed range rings shall be provided for range measurements as follows:

- .1** on the range scale 0.25, 0.5, 0.75 nautical miles at least two and not more than six range rings shall be provided, on each of the other mandatory range scales six range rings shall be provided; and
- .2** where off-centred facilities have been provided, additional range rings shall be provided at the same range intervals.

5.7.14.4.2 An electronic variable range marker in the form of a ring shall be provided with a numeric readout of range. For ranges of less than 1 nautical mile, there shall be only one zero before the decimal point.

5.7.14.4.3 The fixed range rings and the variable range markers shall enable the range of an object to be measured with an error not exceeding 1% of the maximum range of the scale in use, or 30 m, whichever is the greater.

5.7.14.4.4 The accuracy shall be maintained when the display is off-centred.

5.7.14.4.5 The thickness of the fixed range rings shall not be greater than the maximum permissible thickness of the heading line.

5.7.14.4.6 On all range scales, it shall be possible to set the variable range marker with the required precision within 5 s in all cases. A range that is set by the user shall not change automatically when the range scale is changed

5.7.14.5 Heading indication

5.7.14.5.1 The heading of the ship shall be indicated by a continuous line on the display with a maximum error of not greater than $\pm 1^\circ$. The thickness of the displayed heading line shall not be greater than 0.5° measured at maximum range at the edge of the radar display.

5.7.14.5.2 Provision shall be made to switch off the heading indicator by a device which cannot be left in the "heading line off position.

5.7.14.5.3 A heading marker shall be displayed on the bearing scale.

5.7.14.6 Bearing measurement

5.7.14.6.1 An Electronic Bearing Line, (EBL), shall be provided with a numeric readout of bearing to obtain within 5 s the bearing of any object whose echo appears on the display.

5.7.14.6.2 The EBL shall enable the bearing of a target whose echo appears at the edge of the display to be measured with a maximum error of not greater than $\pm 1^\circ$.

5.7.14.6.3 The EBL shall be displayed on the screen in such a way that it is clearly distinguishable from the heading indicator.

5.7.14.6.4 It shall be possible to vary the brilliance of the EBL. This variation may be separate or combined with the intensity of other markers. It shall be possible to remove the EBL completely from the screen.

5.7.14.6.5 The rotation of the EBL shall be possible in both directions continuously or in steps of not more than 0.2° .

5.7.14.6.6 The numeric readout of the bearing of the EBL shall be displayed with at least 4 digits, including one after the decimal point. The EBL readout shall not be used to display any other data. There shall be a positive identification of whether the bearing indicated is a relative bearing or a true bearing.

5.7.14.6.7 A bearing scale around the edge of the display shall be provided. Linear or non-linear scales may be provided.

5.7.14.6.8 The bearing scale shall have division marks for at least each 5° clearly distinguishable from each other. Numbers shall be clearly marked at least at each 30° .

5.7.14.6.9 It shall be possible to measure the bearing relative to the heading line and relative north.

5.7.14.6.10 A minimum of two independent lines of parallel index lines shall be provided.

5.7.14.6.11 Należy zapewnić możliwość przesuwania punktu początkowego elektronicznej linii namiarowej z punktu odpowiadającego pozycji własnej okrętu – w dowolny punkt efektywnej powierzchni wskaźnika. Powinien być możliwy powrót do punktu początkowego przy pomocy szybkiej pojedynczej operacji. Powinno być możliwe wyświetlanie ruchomego znacznika odległości na elektronicznej linii namiarowej.

5.7.14.7 Discrimination

5.7.14.7.1 Radar powinien wskazać jako oddzielne dwa jednakowe obiekty zobrazowane na zakresie 1,5 Mm lub mniejszym, znajdujące się w przedziale od 50 do 100% używanego zakresu odległości i odległe od siebie o nie więcej niż 40 metrów.

5.7.14.7.2 Radar powinien wskazać jako oddzielne dwa jednakowe cele, oba znajdujące się w tej samej odległości od okrętu, zobrazowane na zakresie 1,5 Mm, znajdujące się w przedziale od 50 do 100% używanego zakresu odległości i odległe od siebie w azymucie o nie więcej niż $2,5^\circ$.

5.7.14.8 Roll or pitch

The performance of the equipment shall be such that when the ship is rolling or pitching in the range up to ± 10 , performance requirements of 5.7.14.2 continue to be met.

5.7.14.9 Antenna Scan

The scan shall be clockwise, continuous and automatic through 360° of azimuth. The antenna rotation rate shall be not less than 20 revolutions per minute. The equipment shall operate satisfactorily in relative wind speeds of up to 100 knots. Alternative methods of scanning is permitted provided that the performance is not inferior.

5.7.14.10 Azimuth stabilization

5.7.14.10.1 Means shall be provided to enable the display to be stabilized in azimuth by a compass. The radar shall be provided an input for information from the compass. The accuracy of alignment with the compass transmission shall be within 0.5 with a compass rotation rate of 2 revolutions per minute.

5.7.14.10.2 The equipment shall operate satisfactorily in the head-up unstabilized mode when the azimuth stabilization is inoperative.

5.7.14.10.3 Change over from one display mode to the other shall be possible within 5 s and achieve the required bearing accuracy.

5.7.14.11 Performance monitoring

Means shall be available, while the equipment is used operationally, to determine readily a significant drop in system performance relative to a calibration standard established at the time of installation. Means shall be provided to check that the equipment is correctly tuned in the absence of targets.

5.7.14.12 Anti-clutter devices

5.7.14.12.1 Suitable means shall be provided for the suppression of unwanted echoes from sea clutter, rain and other forms of precipitation, clouds, sandstorms and from other radars. It shall be possible to adjust manually and continuously the anti-clutter controls. In addition, automatic anti-clutter controls may be provided; however, they shall be capable of being switched off.

5.7.14.12.2 The operational requirement, when the radar antenna is mounted at a height of 15 m above sea level, is that the equipment shall, even in the presence of sea clutter, give a clear indication of a standard reflector up to 3.5 nautical miles

5.7.14.13 Operation

5.7.14.13.1 The equipment shall be capable of being switched on and off and operated from the master display position.

5.7.14.13.2 After switching on from cold the equipment shall become fully operational within 4 min.

5.7.14.13.3 A stand-by condition shall be provided from which the equipment can be brought to an operational condition within 15 s.

5.7.14.13.4 It shall be possible to vary the brilliance of the fixed range rings and the variable range markers and electronic bearing lines and to remove them independently and completely from the display.

5.7.14.13.5 For radars with additional synthetic information (e.g. target identifiers, vectors, navigational information), means shall be provided capable of removing this additional information from the screen.

5.7.14.14 Interference

After installation and adjustment on board, the required bearing accuracy shall be maintained without further adjustment irrespective of the movement of the ship in the earth's magnetic field..

5.7.14.15 Display modes

5.7.14.15.1 The equipment shall be capable of operating in relative and true motion.

5.7.14.15.2 The radar origin shall be capable of being off-set to at least 50% and not more than 75% of the radius of the display.

5.7.14.15.3 The radar shall be capable of sea and ground stabilisation. With sea or ground stabilisation the accuracy and discrimination of the display shall be at least equivalent to that required by 5.7.14.4 and 5.7.14.7.

5.7.14.15.4 The radar shall accept signals from the speed and distance measuring equipment (SDME) in the fore and aft direction..

5.7.14.15.5 The ground stabilized input shall accept signals provided from the SDME, from an electronic position-fixing system and from radar tracked stationary targets. The speed accuracy shall not be less than 2% of the ship's speed or 0,2 knots, whichever is the greater.

5.7.14.15.6 The type of input and stabilisation in use shall be displayed.

5.7.14.15.7 It shall also be possible to input the ship's speed manually from 0 (zero) knots to 30 knots in steps of not more than 0.2 knots.

5.7.14.15.8 Provision shall be made for manual input of set and drift..

5.7.14.16 Radar beacons and radar transponders detection

5.7.14.16.1 Radar shall be able to detect and display signals from radar beacons and radar transponders operating in 9 GHz band.

5.7.14.16.2 All radars operating in the 9 GHz band shall be capable of operating in a horizontally polarized mode. If other polarization modes are available there shall be a positive indication of their use on the display.

5.7.14.16.3 It shall be possible to switch off those signal processing facilities which might prevent a radar beacon from being shown on the radar display..

5.7.14.17 Failure Warnings

If there is any detectable reason why the information presented to the operator is invalid adequate and clear warning shall be given to the operator.

5.7.14.18 Interface

5.7.14.18.1 The radar system shall be capable of receiving information from equipment such as gyro-compass, speed and distance measurement equipment (SDME) and electronic position-fixing systems (EPFS) in accordance with *IEC Publication 1162*. The source of received information shall be capable of being displayed.

5.7.14.18.2 The radar shall provide an indication when any input from an external sensor is absent. The radar shall also repeat any alarms or status messages concerning the quality of the input data from it's external sensors.

5.7.15 Navigational information

The radar display shall be capable of presenting in graphical form, positions, navigational lines and maps, in addition to the radar information. It shall be possible to adjust these points, lines and maps relative to a geographical reference. The source of the graphical information and the method of geographical referencing shall be clearly indicated.

5.7.15.1 Plotting

5.7.15.1.1 If the radar is provided with ARPA, the latter shall conform with the requirements of 5.7.16.

5.7.15.1.2 If the radar is provided with ATA, the latter shall conform with the requirements of 5.7.17.

5.7.15.1.3 If the radar is provided with EPA, the latter shall conform with the requirements of 5.7.18.

5.7.16 Automatic radar plotting aid (ARPA) (acc. to Res. A.823(19))

5.7.16.1 Introduction

The radar facilities provided by an ARPA display shall comply with the performance standards for radar equipment described in 5.7.14.

5.7.16.2 Target acquisition

5.7.16.2.1 Target acquisition may be manual or automatic for relative speeds up to 100 knots. However, there shall always be a facility to provide for manual acquisition and cancellation: ARPA with automatic acquisition shall have a facility to suppress acquisition in certain areas. On any range scale where acquisition is suppressed over a certain area, the area of acquisition shall be defined and indicated on the display.

5.7.16.2.2 Automatic or manual acquisition shall have a performance not inferior to that which could be obtained by the user of the radar display.

5.7.16.3 Tracking

5.7.16.3.1 The ARPA shall be able automatically to track, process, simultaneously display and continuously update the information on at least 20 targets, whether automatically or manually acquired.

5.7.16.3.2 If automatic acquisition is provided, description of the criteria of selection of targets for tracking shall be provided to the user. If the ARPA does not track all targets visible on the display, targets which are being tracked shall be clearly indicated on the display in accordance with *IEC Publication 872*. The reliability of tracking shall not be less than that obtainable using manual recordings of successive target positions obtained from the radar display.

5.7.16.3.3 The ARPA shall continue to track an acquired target which is clearly distinguishable on the display for 5 out of 10 consecutive scans, provided the target is not subject to target swop.

5.7.16.3.4 The possibility of tracking errors, including target swop, shall be minimized by ARPA design. A qualitative description of the effects of error sources on the automatic tracking and corresponding errors shall be provided to the user, including the effects of low signal-to-noise and low signal-to-clutter ratios caused by sea returns, rain, snow, low clouds and non-synchronous emissions.

5.7.16.3.5 The ARPA shall be able to display on demand with relevant symbol conforming with *IEC Publication 872* at least four equally time-spaced past positions of any targets being tracked over a period of, at least, the last eight minutes.

5.7.16.4 Display

5.7.16.4.1 The display may be a separate or integral part of the ship's radar. However, the ARPA display shall include all the data required to be provided by a radar display in accordance with the performance standards for navigational radar equipment.

5.7.16.4.2 The design shall be such that any malfunction of ARPA parts producing data additional to information to be produced by the radar as required by the performance standards for navigational equipment shall not affect the integrity of the basic radar presentation.

5.7.16.4.3 The ARPA facilities shall be available on at least 3, 6 and 12 nautical mile range scales. ARPA facilities may also be provided on other range permitted, scales and there shall be a positive indication of the range scale in use.

5.7.16.4.4 The ARPA shall be capable of operating with a relative motion display with "north-up" and "course-up" azimuth stabilization. In addition, the ARPA may also provide for a true motion display. If true motion is provided, the operator shall be able to select for the display either true or relative motion. There shall be a positive indication of the display mode and orientation in use.

5.7.16.4.5 The course and speed information generated by the ARPA for acquired targets shall be displayed in a vector or graphic form which clearly indicates the target's predicted motion with relevant symbols conforming with *IEC Publication 872*. In this regard:

- .1 an ARPA presenting predicted information in vector form only shall have the option of choosing both true and relative motion vectors;;
- .2 an ARPA which is capable of presenting target course and speed information in graphic form shall also, on demand, provide the target's true and/or relative vector;
- .3 vectors displayed shall be time-adjustable;
- .4 if stationary targets are being used for ground referencing, this fact shall be indicated by the relevant symbol conforming with *IEC Publication 872*. In this mode, relative vectors including those of the targets used for ground referencing shall be displayed when requested.

5.7.16.4.6 The ARPA information shall not obscure the visibility of radar targets. The display of ARPA data shall be under the control of the radar observer. It shall be possible to cancel the display of unwanted ARPA data within 3 s.

5.7.16.4.7 Means shall be provided to adjust independently the brilliance of the ARPA data and radar data, including complete extinction of the ARPA data..

5.7.16.4.8 The method of presentation shall ensure that the ARPA data are clearly visible in general to more than one observer in the conditions of light normally experienced on the bridge of a ship by day and by night.

5.7.16.4.9 Screening may be provided to shade the display from sunlight but not to the extent that it will impair the observer's ability to maintain a proper look-out. Facilities to adjust the brightness shall be provided..

5.7.16.4.10 Provisions shall be made to obtain quickly the range and bearing of any object which appears on the ARPA display.

5.7.16.4.11 When a target appears on the radar display and, in the case of automatic acquisition, enters within the acquisition area chosen by the observer or, in the case of manual acquisition, has been acquired by the observer, the ARPA shall present in a period of not more than 1 min an indication of the target's motion trend, and display within 3 min the target's predicted motion in accordance with 5.7.16.4.5, 5.7.16.7, 5.7.16.8.2, 5.7.16.8.3.

5.7.16.4.12 After changing range scales on which the ARPA facilities are available or resetting the display, full plotting information shall be displayed within a period of time not exceeding one scan.

5.7.16.5 Operational warnings

5.7.16.5.1 The ARPA shall have the capability to warn the observer with a visual and audible signal of any distinguishable target which closes to a range or transits a zone chosen by the observer. The target causing the warning shall be clearly indicated on the display with symbols conforming with *IEC Publication 872*.

5.7.16.5.2 The ARPA shall have the capability to warn the observer with a visual and audible signal of any tracked target which is predicted to close within a minimum range and time chosen by the observer. The target causing the warning shall be clearly indicated on the display with relevant symbols conforming with *IEC Publication 872*.

5.7.16.5.3 The ARPA shall clearly indicate if a tracked target is lost, other than out of range, and the target's last tracked position shall be clearly indicated on the display.

5.7.16.5.4 It shall be possible for the observer to activate or de-activate the audible warning signal.

5.7.16.6 Data requirements

5.7.16.6.1 The observer shall be able to select any tracked target to obtain data. Targets selected shall be marked on the radar display with the symbol conforming with *IEC Publication 872*. If data is required for more than one target at the same time each symbol shall be separately identified, for example with a number adjacent to the symbol.

5.7.16.6.2 Na żądanie obserwatora urządzenie ARPA powinno wyświetlać w formie alfanumerycznej, na zewnątrz zobrazenia radarowego, następujące informacje o dowolnym śledzonym obiekcie:

- .1 present range of the target;
- .2 present bearing of the target;
- .3 predicted target range at the closest point of approach (CPA);
- .4 predicted time to CPA (TCPA);

- .5 calculated true course of the target; and
- .6 calculated true speed of the target.

5.7.16.6.3 The display of the data in 5.7.16.6.2.5 and 5.7.16.6.2.6 shall include an identification of whether the data provided is referenced to sea or ground stabilization.

5.7.16.6.4 When data for several targets is displayed, no fewer than two items listed in 5.7.16.6.2 shall be displayed simultaneously for each target selected. If the items of data are displayed in pairs for each target, the groupings shall be: 5.7.16.6.2.1 with 5.7.16.6.2.2, 5.7.16.6.2.3 with 5.7.16.6.2.4, 5.7.16.6.2.5 with 5.7.16.6.2.6.

5.7.16.7 Trial manoeuvre

5.7.16.7.1 The ARPA shall be capable of simulating the effect on all tracked targets of an own ship manoeuvre with or without time delay before manoeuvre without interrupting the updating of target tracking and display of actual target alpha-numeric data. The simulation shall be indicated on the display with the relevant symbol conforming with *IEC Publication 872*.

5.7.16.7.2 The ARPA operating manual shall contain an explanation of the principles underlying the trial manoeuvre technique adopted including, if provided, the simulation of own ship's manoeuvring characteristics.

5.7.16.7.3 It shall be possible to cancel a trial manoeuvre at any time.

5.7.16.8 Accuracy

5.7.16.8.1 The ARPA shall provide accuracies not less than those given in 5.7.16.8.2 and 5.7.16.8.3 and for the four scenarios defined in Table 5.7.16.8.6. With the sensor errors specified in 5.7.16.8.7, the values given relate to the best possible manual plotting performance under environmental conditions of ± 10 degrees of roll.

5.7.16.8.2 An ARPA shall present within one minute of steady state tracking the relative motion trend of a target with the accuracy values presented in Table 5.7.16.8.2 (95% probability values).

Table 5.7.16.8.2
Values of permissible errors in motion data of the target within one minute of steady state tracking

Data	Relative course (degrees)	Relative speed (knots)	CPA (nautical miles)
1	11	2,8	1,6
2	7	0,6	–
3	14	2,2	1,8
4	15	1,5	2,0

Notes:

1. In steady state tracking both own and target ship follow straight line course at constant speed.
2. Probability values are the same as confidence levels.

5.7.16.8.3 An ARPA shall present within three minutes of steady state tracking the motion of a target with the accuracy values presented in Table 5.7.16.8.3 (95% probability values).

Table 5.7.16.8.3
Values of permissible errors in motion parameters of the target within three minutes of steady state tracking

Data	Relative course (degrees)	Relative speed (knots)	CPA (nautical miles)	TCPA (min)	True course (degrees)	True speed (knots)
1	3,0	0,8	0,5	1,0	7,4	1,2
2	2,3	0,3	–	–	2,8	0,8
3	4,4	0,9	0,7	1,0	3,3	1,0
4	4,6	0,8	0,7	1,0	2,6	1,2

5.7.16.8.4 When a tracked target, or own ship, has completed a manoeuvre, the system shall present in a period of not more than 1 min an indication of the target's motion trend, and display within 3 min the target's predicted motion, in accordance with 5.7.16.4.5, 5.7.16.6, 5.7.16.8.2 and 5.7.16.8.3. In this context, a "manoeuvre of own ship" shall be deemed to consist of an alteration of course of $\pm 45^\circ$ in 1 min.

5.7.16.8.5 The ARPA shall be designed in such a manner that under the most favourable conditions of own ship's motion the error contribution from the ARPA shall remain insignificant compared to the errors associated with the input sensors, for the navigation scenarios prescribed in Table 5.7.16.8.6.

5.7.16.8.6 Accuracy of targets' position, referred to in 5.7.16.8.5, for each of the navigational scenarios defined in Table 5.7.16.8.6, shall be determined after previously tracking for the appropriate time of one or three minutes.

Table 5.7.16.8.6
Definitions of navigational scenarios, for which the requirements for ARPA are determined

Navigational scenario	Own ship course (degrees)	Own ship speed (knots)	Target range (nautical miles)	Bearing of target (degrees)	Relative course of target (degrees)	Relative speed of target (knots)
1	000	10	8	000	180	20
2	000	10	1	000	090	10
3	000	5	8	045	225	20
4	000	25	8	045	225	20

5.7.16.8.7 The accuracy figures quoted in 5.7.16.8.2 and 5.7.16.8.3 shall be determined on the basis the following errors, introduced by the sensors complying with the requirements of the present chapter:

Note: σ – means "standard deviation".

.1 Radar:

- a) target glint (scintillation) (for 200 m length target):
 - along length of target $\sigma = 30$ m (normal distribution);
 - across beam of target $\sigma = 1$ m (normal distribution).
- b) roll-pitch bearing:

the bearing error will peak in each of the four quadrants around own ship for targets on relative bearings of 045° , 135° , 225° and 315° , and will be zero at relative bearings of 0° , 90° , 180° and 270° ;

this error has a sinusoidal variation at twice the roll frequency; for a 10° roll the mean error is 0.22° with a 0.22° peak sine wave superimposed;

- c) beam shape: assumed normal distribution giving bearing error with $\sigma = 0,05^\circ$;
- d) pulse shape: assumed normal distribution giving range error with $\sigma = 20$ m;
- e) antenna backlash: assumed rectangular distribution giving bearing error $\pm 0.05^\circ$ maximum
- f) quantization:
 - bearing - rectangular distribution $\pm 0.1^\circ$ maximum;
 - range - rectangular distribution ± 0.01 nautical miles maximum;
 - bearing encoder assumed to be running from a remote synchro giving bearing errors with a normal distribution $s = 0.03^\circ$.

.2 Gyro-compass:

- calibration error 0.5° ; $\sigma = 0,12^\circ$ for normal distribution;

.3 Log:

- calibration error 0.5 knots; $3\sigma = 0,2$ knots for normal distribution.

5.7.16.9 Connections with other equipment

5.7.16.9.1 The ARPA shall not degrade the performance of any equipment providing sensor inputs, and the connection of the ARPA to any other equipment shall not degrade the performance of that equipment. This requirement shall be met whether the ARPA is operating or not. Additionally, the ARPA shall be designed to comply with this requirement under fault conditions as far as is practicable.

5.7.16.9.2 The ARPA shall provide an indication when any input from an external sensor is absent. The ARPA shall also repeat any alarm or status messages concerning the quality of the input data from its external sensors which may influence its operation.

5.7.16.10 Performance tests and warnings

The ARPA shall provide suitable warnings of ARPA malfunction to enable the observer to monitor the proper operation of the system. Additionally, test programmes shall be available so that the overall performance of ARPA can be assessed periodically against a known solution. When a test programme is being executed, the relevant test symbols conforming with *IEC Publication 872* shall be displayed.

5.7.16.11 Sea and ground stabilization

5.7.16.11.1 The ARPA shall be capable of sea and ground stabilization.

5.7.16.11.2 Log and speed indicators providing inputs to ARPA equipment shall be capable of providing the ship's speed through the water in the fore and aft direction. ARPA shall accept and identify input signals of speed and distance in the fore and aft direction.

5.7.16.11.3 The ground stabilized input may be provided from the log, from an electronic position-fixing system, if the speed measurement accuracy is in accordance with the requirements of 5.7.11.3, or from tracked stationary targets.

5.7.16.11.4 The type of input and stabilization in use shall be displayed.

5.7.17 Automatic tracking aid (ATA) (*Res. MSC.64(67) Annex 4*)

5.7.17.1 Acquisition

5.7.17.1.1 There shall be a facility to provide for manual acquisition and cancellation for relative speeds up to 100 knots.

5.7.17.1.2 Manual acquisition shall have a performance not inferior to that which could be obtained by the user of the radar display.

5.7.17.2 Tracking

5.7.17.2.1 ATA shall be able to automatically track, process, simultaneously display and continuously update the information on at least 10 targets.

5.7.17.2.2 ATA shall continue to track an acquired target which is clearly distinguishable on the display for 5 out of 10 consecutive scans, provided the target is not subject to target swop.

5.7.17.2.3 The possibility of tracking errors, including target swop, shall be minimised by ATA design. A qualitative description of the effects of error sources on the automatic tracking and corresponding errors shall be provided to the user, including the effects of low signal-to-noise and low signal-to-clutter ratios caused by sea returns, rain, snow, low clouds and non-synchronous emissions.

5.7.17.3 ATA display

5.7.17.3.1 The display may be separate or integral part of the ship's radar. However the ATA display shall include all the data required to be provided by a radar display in accordance with performance standards for navigational radar equipment.

5.7.17.3.2 The design shall be such that any malfunction of ATA parts producing data additional to information to be produced by the radar as required by the performance standards for navigational equipment shall not affect the integrity of the basic radar presentation.

5.7.17.3.3 The ATA facilities shall be available on at least the 3,6 and 12 nautical mile range scales, and there could be a positive indication of the range scale in use. ATA may also be provided on other range scales.

5.7.17.3.4 The ATA shall be capable of operating with a relative motion display with "north-up" and "course-up" azimuth stabilization. In addition, the ATA may also provide for a true motion display. If true motion is provided, the operator shall be able to select for his display either true or relative motion. There shall be a positive indication of the display mode and orientation in use.

5.7.17.3.5 The course and speed information generated by the ATA for acquired targets shall be displayed in a vector or graphic form which clearly indicates the target's predicted motion with relevant symbols conforming with *IEC Publication 872*. In this regard:

- .1** ATA presenting predicted information in vector form only shall have the option of both true and relative vectors;
- .2** ATA which is capable of presenting target course and speed information in graphic form shall also, on demand, provide the target's true and/or relative vector;
- .3** vectors displayed shall be time adjustable;
- .4** if stationary targets are being used for ground referencing then this shall be indicated with the relevant symbol conforming with *IEC Publication 872*.

5.7.17.3.6 The ATA information shall not obscure the visibility of radar targets. The display of "auto tracking" data shall be under the control of the radar observer. It shall be possible to cancel the display of unwanted ATA data within 3 s.

5.7.17.3.7 Means shall be provided to adjust independently the brilliance of the ATA data and radar data, including complete extinction of the ATA data.

5.7.17.3.8 The method of presentation shall ensure that the ATA data are clearly visible in general to more than one observer in the conditions of light normally experienced on the bridge of a ship by day and by night.

5.7.17.3.9 Screening may be provided to shade the display from sunlight but not to the extent that it will impair the observer's ability to maintain a proper look-out. Facilities to adjust the brightness shall be provided.

5.7.17.3.10 Provisions shall be made to obtain quickly the range and bearing of any object which appears on the ATA display.

5.7.17.3.11 The ATA shall present in a period of not more than 1 min an indication of the target's motion trend and display within 3 min the target's predicted motion in accordance with paragraphs 5.7.17.3.5, 5.7.17.5, 5.7.17.6.2 and 5.7.17.6.3.

5.7.17.3.12 After changing range scales on which the ATA facilities are available or resetting the display, full plotting information shall be displayed within a period of time not exceeding one scan.

5.7.17.4 Operational warnings

5.7.17.4.1 The "auto tracking" shall have the capability to warn the observer with a visual and audible signal of any distinguishable target which closes to a range or transits a zone chosen by the observer. The target causing the warning shall be clearly indicated on the display with the relevant symbols conforming with *IEC Publication 872*.

5.7.17.4.2 The ATA shall have the capability to warn the observer with a visual and audible signal of any tracked target which is predicted to close within a minimum range and time chosen by the observer. The target causing the warning shall be clearly indicated on the display with the relevant symbols conforming with *IEC Publication 872*.

5.7.17.4.3 The ATA shall clearly indicate if a tracked target is lost, other than out of range, and the target's last tracked position shall be clearly indicated on the display.

5.7.17.4.4 It shall be possible for the observer to activate or de-activate the audible warning capability.

5.7.17.5 Data requirements

5.7.17.5.1 The observer shall be able to select any tracked target to obtain data. Targets selected shall be marked on the radar display with the relevant symbol conforming with *IEC Publication 872*. If data is required for more than one target at the same time each symbol shall be separately identified, for example with a number adjacent to the symbol.

5.7.17.5.2 On the observer's demand the following data for each selected target shall be clearly and unambiguously identified and displayed immediately and simultaneously in alpha-numeric form outside the radar area:

- .1** present range of the target;
- .2** present bearing of the target;
- .3** predicted target range at the closest point of approach (CPA);

- .4 predicted time to CPA (TCPA);
- .5 calculated true course of the target; and
- .6 calculated true speed of the target.

5.7.17.5.3 The display of items 5.7.17.5.2.5 and 5.7.17.5.2.6 shall include an identification of whether the data uses sea or ground reference.

5.7.17.5.4 When data for several targets is displayed, not less than two items (from 5.7.17.5.2) shall be displayed simultaneously for each target selected. If the items of data are displayed in pairs for each target the groupings shall be: 5.7.17.5.2.1 with 5.7.17.5.2.2, 5.7.17.5.2.3 with 5.7.17.5.2.4, 5.7.17.5.2.5 with 5.7.17.5.2.6.

5.7.17.6 Accuracy

5.7.17.6.1 The ATA shall provide accuracies not less than those given in paragraphs 5.7.17.6.2 and 5.7.17.6.3 for the four scenarios defined in Table 5.7.17.6.2. With the sensor errors specified in 5.7.17.6, the values given relate to the best possible manual plotting performance under environmental conditions of $\pm 10^\circ$ of roll.

5.7.17.6.2 The ATA shall present within 1 min of steady state tracking the relative motion trend of a target with the accuracy values presented in Table 5.7.17.6.2 (95% probability).

Table 5.7.17.6.2
Values of permissible errors in motion data of the target within one minute of steady state tracking

Scenario	Data	Relative course (degrees)	Relative speed (knots)	CPA (nautical miles)
1		11	2,8	1,6
2		7	0,6	–
3		14	2,2	1,8
4		15	1,5	2,0

Notes:

1. In steady state tracking both own and target ship follow straight line course at constant speed.
2. Probability values are the same as confidence levels.

5.7.17.6.3 The ATA shall present within 3 min of steady state tracking the motion of a target with the accuracy values presented in Table 5.7.17.6.3 (95% probability).

Table 5.7.17.6.3
Values of permissible errors in motion data of the target within three minutes of steady state tracking

Data Scenario	Relative course (degrees)	Relative speed (knots)	CPA (nautical miles)	TCPA (minutes)	True course (degrees)	True speed (knots)
1	3,0	0,8	0,5	1,0	7,4	1,2
2	2,3	0,3	–	–	2,8	0,8
3	4,4	0,9	0,7	1,0	3,3	1,0
4	4,6	0,8	0,7	1,0	2,6	1,2

5.7.17.6.4 When a tracked target, or own ship, has completed a manoeuvre, the ATA system shall present in a period of not more than 1 min an indication of the target's motion trend, and display within 3 min the target's predicted motion, in accordance with 5.7.17.6.5, 5.7.17.5, 5.7.17.6.2 and 5.7.17.6.3. In this context, a "manoeuvre of own ship" shall be deemed to consist of an alteration of course of $\pm 45^\circ$ in 1 min.

5.7.17.6.5 The ATA shall be designed in such a manner that under the most favourable conditions of own ship's motion the error contribution from the ATA shall remain insignificant compared to the errors associated with the input sensors, for the navigation scenarios prescribed in Table 5.7.17.6.6..

5.7.17.6.6 Accuracy of targets' position, referred to in 5.7.17.6.5, for each of the navigational scenarios defined in Table 5.7.17.6.6, shall be determined after previously tracking for the appropriate time of one or three minutes.

Table 5.7.17.6.6
Definitions of navigational scenarios, for which the requirements for ATA are determined

Navigational scenario	Own ship course (degrees)	Own ship speed (knots)	Target range (nautical miles)	Bearing of target (degrees)	Relative course of target (degrees)	Relative speed of target (knots)
1	000	10	8	000	180	20
2	000	10	1	000	090	10
3	000	5	8	045	225	20
4	000	25	8	045	225	20

5.7.17.6.7 The accuracy figures quoted in 5.7.17.6.2 and 5.7.17.6.3 shall be determined on the basis the following errors, introduced by the sensors complying with the requirements of the present chapter:

Note: σ – means "standard deviation".

.1 Radar:

- a) target glint (scintillation) (for 200 m length target):
 - along length of target $\sigma = 30$ m (normal distribution);
 - across beam of target $\sigma = 1$ m (normal distribution).
- b) roll-pitch bearing:
 - the bearing error will peak in each of the four quadrants around own ship for targets on relative bearings of 045° , 135° , 225° and 315° , and will be zero at relative bearings of 0° , 90° , 180° and 270° ;
 - this error has a sinusoidal variation at twice the roll frequency; for a 10° roll the mean error is 0.22° with a 0.22° peak sine wave superimposed;
- c) beam shape: assumed normal distribution giving bearing error with $\sigma = 0,05^\circ$;
- d) pulse shape: assumed normal distribution giving range error with $\sigma = 20$ m;
- e) antenna backlash: assumed rectangular distribution giving bearing error $\pm 0.05^\circ$ maximum
- f) quantization:
 - bearing - rectangular distribution $\pm 0.1^\circ$ maximum;
 - range - rectangular distribution ± 0.01 nautical miles maximum;
 - bearing encoder assumed to be running from a remote synchro giving bearing errors with a normal distribution $s = 0.03^\circ$.

.2 Gyro-compass:

- calibration error 0.5° ; $\sigma = 0,12^\circ$ for normal distribution;

.3 Log:

- calibration error 0.5 knots; $3\sigma = 0,2$ knots for normal distribution.

5.7.17.7 Connections with other equipment

The ATA shall not degrade the performance of any equipment providing sensor inputs, and the connection of the ATA to any other equipment shall not degrade the performance of that equipment. This requirement shall be met whether the ATA is operating or not. Additionally, the ATA shall be designed to comply with this requirement under fault conditions as far as is practicable.

5.7.17.8 Performance tests and warnings

The ATA shall provide suitable warnings of ATA malfunction to enable the observer to monitor the proper operation of the system. Additionally, test programmes shall be available so that the overall performance of ATA can be assessed periodically against a known solution. When a test programme is being executed, the relevant test symbols conforming with *IEC Publication 872* shall be displayed..

5.7.17.9 Sea and ground stabilization

5.7.17.9.1 The ATA shall be capable of accepting and distinguishing input signals of sea and ground stabilization.

5.7.17.9.2 The ATA shall be capable of accepting and distinguishing input signals of the speed through the water in the fore and aft direction.

5.7.17.9.3 ATA shall co-operate with the devices indicating the ship's heading.

5.7.17.9.4 If the ground stabilized input is provided from the log, from an electronic position-fixing system, or from tracked stationary targets than the display shall indicate which of them is currently in use.

5.7.17.9.5 The type of input and stabilization in use shall be displayed.

5.7.18 Electronic plotting aid (EPA) (Res. MSC.64(67) Aneks 4)

5.7.18.1 The electronic plotting aid shall provide a means to plot a minimum of 10 targets on a radar display. It shall be possible to plot targets on the 3,6 and 12 nautical mile range scales. The facility may be provided on additional range scales.

5.7.18.2 It shall be possible to plot targets with a relative speed up to 75 knots.

5.7.18.3 It shall be possible for the operator to adjust the CPA/TCPA limits and the vector time.

5.7.18.4 Plot positions shall be identified by an approved symbol and an associated plot number. It shall be possible to switch off the plot number.

5.7.18.5 The minimum lapsed time between any two plots shall be greater than 30 s.

5.7.18.6 After the second plot, a vector shall be displayed on the target. It shall be possible to select a true or relative vector. There shall be a positive indication of vector mode.

5.7.18.7 The vector origin shall move across the screen at a rate and direction defined by the calculated true course and speed.

5.7.18.8 It shall be possible to correct the position of a plot.

5.7.18.9 It shall be possible, on the observers demand, to display the following data on a selected target:

- .1** plot number: time since last plot (min);
- .2** present range of the target;
- .3** present bearing of the target;
- .4** predicted target range at the closest point of approach (CPA);
- .5** predicted time to CPA (TCPA);

- .6 calculated true course of target;
- .7 calculated true speed of target.
- .8 The selected plot shall be clearly identified with an approved symbol and the plot data shall be displayed outside of the screen radar area.

5.7.18.10 There shall be an indication of any plot that is not updated for 10 min. The plot shall be dropped if the time between consecutive plots exceeds 15 min.

5.7.19 Electronic chart display and information systems (ECDIS)/Raster chart display system (RCDS) (*acc. to Res. A.817(19), Res. MSC.64(67) Annex 5 i Res. MSC.86(70) Annex 4*)

5.7.19.1 Introduction

5.7.19.1.1 ECDIS, with adequate back-up arrangements, may be accepted as complying with the up-to-date charts required by regulation V/20 of the *1974 SOLAS Convention*. When operating in the RCDS mode, ECDIS equipment shall be used together with an appropriate portfolio of up-to-date paper charts..

5.7.19.1.2 In the case that ENC are not available, ECDIS may operate in RCDS display mode.

5.7.19.1.3 All requirements related to ECDIS are indicated as to whether they apply to RCDS, do not apply to RCDS, or are modified in order to apply to RCDS.

5.7.19.1.4 Whenever any requirement related to ECDIS applies also to RCDS, then, interpreting it in terms of RCDS, term ECDIS shall be substituted by RCDS, SENC by SRNC and ENC by RNC, as appropriate.

5.7.19.1.5 ECDIS shall have at least the same reliability and availability of presentation as the paper chart published by government-authorized hydrographic offices. The requirement applies also to RCDS.

5.7.19.1.6 ECDIS shall be capable of displaying all chart information necessary for safe and efficient navigation originated by, and distributed on the authority of, government-authorized hydrographic offices. The requirement applies also to RCDS.

5.7.19.1.7 ECDIS shall facilitate simple and reliable updating of the electronic navigational chart. The requirement applies also to RCDS.

5.7.19.1.8 ECDIS shall provide appropriate alarms or indications with respect to the information displayed or malfunction of the equipment. The requirement applies also to RCDS.

5.7.19.2 Display

5.7.19.2.1 ECDIS shall be designed following ergonomic principles for user-friendly operation. The requirement applies also to RCDS.

5.7.19.2.2 ECDIS shall be capable of displaying information for:

- .1 route planning and supplementary navigation tasks;
- .2 route monitoring.

The requirement applies also to RCDS.

5.7.19.2.3 The effective size of the chart presentation for route monitoring shall be at least 270 mm by 270 mm. The requirement applies also to RCDS.

5.7.19.2.4 The display symbols and colours shall comply with the requirements of *IHO Publication S-52*. The requirement does not apply to RCDS.

5.7.19.2.5 The method of presentation shall ensure that the displayed information is clearly visible to more than one observer in the conditions of light normally experienced on the bridge of the ship by day and by night.. The requirement applies also to RCDS.

5.7.19.3 Display of SENC information

5.7.19.3.1 ECDIS shall be capable of displaying all SENC information. The requirement applies also to RCDS.

5.7.19.3.2 SENC information available for display during route planning and route monitoring shall be subdivided into three categories, display base, standard display, and all other information.

5.7.19.3.3 In the case of RCDS, SRNC information available for display during route planning and route monitoring shall be subdivided into two categories: the RCDS standard display consisting of RNC and its updates, including its scale, the scale at which it is displayed, its horizontal datum, and its units of depths and heights, and any other information, such as mariner's notes.

5.7.19.3.4 ECDIS shall present the standard display at any time by a single operator action. The requirement applies also to RCDS.

5.7.19.3.5 When a chart is first displayed on ECDIS, it shall provide the standard display at the largest scale available in the SENC for the displayed area. Kiedy wyświetlana jest rastrowa mapa nawigacyjna RNC, wskaźnik powinien podawać informację, jeżeli zaistnieje taka sytuacja, że dla wyświetlanego obszaru dostępna jest bardziej szczegółowa (w większej skali) mapa RNC.

5.7.19.3.6 It shall be easy to add or remove information from the ECDIS display. It shall not be possible to remove information contained in the display base. Powinna być zapewniona możliwość łatwego wprowadzania i usuwania ze wskaźnika RCDS dodatkowych informacji w stosunku do zawartości RNC, takich jak np. notatki operatora. Dane podstawowe mapy RNC nie mogą być usuwalne.

5.7.19.3.7 It shall be possible for the mariner to select a demanded depth contour and ECDIS shall give that contour more emphasis than other contours on the display. The requirement does not apply to RCDS.

5.7.19.3.8 It shall be possible for the mariner to select a safety depth. ECDIS shall emphasize soundings equal to or less than the safety depth whenever spot soundings are selected for display. The requirement does not apply to RCDS.

5.7.19.3.9 The ENC and all updates to it shall be displayed without any degradation of their information content. The requirement applies also to RCDS.

5.7.19.3.10 ECDIS shall provide a means of ensuring that the ENC and all updates to it have been correctly loaded into the SENC. The requirement applies also to RCDS.

5.7.19.3.11 The ENC data and updates to it shall be clearly distinguishable from other displayed information. The requirement applies also to RCDS.

5.7.19.3.12 Whenever ECDIS operates in RCDS mode, the adequate information shall always be visible.

5.7.19.4 Updating of ENC

5.7.19.4.1 It shall not be possible to alter the contents of the ENC. The requirement applies also to RCDS.

5.7.19.4.2 ECDIS shall be capable of accepting official updates to the ENC data provided in conformity with IHO standards. These updates shall be automatically applied to the SENC. By whatever means updates are received, the implementation procedure shall not interfere with the display in use. The requirement applies also to RCDS..

5.7.19.4.3 Updates shall be stored separately from the ENC. The requirement applies also to RCDS.

5.7.19.4.4 ECDIS shall also be capable of accepting updates to the ENC data entered manually with simple means for verification prior to the final acceptance of the data. They shall be distinguishable on the display from ENC information and its official updates, and not affect display legibility. The requirement applies also to RCDS.

5.7.19.4.5 ECDIS shall keep a record of updates, including time of application to the SENC. The requirement applies also to RCDS.

5.7.19.4.6 ECDIS shall allow the mariner to display updates so that the mariner may review their contents and ascertain that they have been included in the SENC. The requirement applies also to RCDS.

5.7.19.5 Display of other navigational information

5.7.19.5.1 Radar information or other navigational information may be added to the ECDIS display. However, it shall not degrade the SENC information, and shall be clearly distinguishable from the SENC information. The requirement applies also to RCDS.

5.7.19.5.2 ECDIS and added navigational information shall use a common reference system. If this is not the case, an indication shall be provided. The requirement applies also to RCDS.

5.7.19.6 Radar

5.7.19.6.1 Transferred radar information may contain both the radar image and ARPA information. The requirement applies also to RCDS.

5.7.19.6.2 If the radar image is added to the ECDIS display, the chart and the radar image shall match in scale and in orientation. The requirement applies also to RCDS.

5.7.19.6.3 The radar image and the position from the position sensor shall both be adjusted automatically for antenna offset from the conning position. The requirement applies also to RCDS.

5.7.19.6.4 It shall be possible to adjust the displayed position of the ship manually so that the radar image matches the SENC display. The requirement applies also to RCDS.

5.7.19.6.5 It shall be possible to remove the radar information by single operator action. The requirement applies also to RCDS.

5.7.19.7 Scale

5.7.19.7.1 ECDIS shall provide an indication of whether:

- .1 the information is displayed at a larger scale than that contained in the ENC; or
- .2 own ship's position is covered by an ENC at a larger scale than that provided by the display.

The requirement applies also to RCDS.

5.7.19.8 Display

5.7.19.8.1 It shall be possible to display the SENC in a "north-up" orientation. Other orientations are permitted. It shall be possible to display the RNC in a "north-up" orientation. Other orientations are permitted..

5.7.19.8.2 ECDIS shall provide for true motion mode. Other modes are permitted. The requirement applies also to RCDS.

5.7.19.8.3 When true motion mode is in use, reset and generation of the neighbouring area shall take place automatically at a distance from the border of the display determined by the mariner. The requirement applies also to RCDS.

5.7.19.8.4 It shall be possible manually to change the chart area and the position of own ship relative to the edge of the display. The requirement applies also to RCDS.

5.7.19.9 Colours and symbols

5.7.19.9.1 To represent SENC and SRNC information *IHO Publication S-52* recommended colours and symbols shall be used.

5.7.19.9.2 The colours and symbols other than those mentioned in 5.7.19.9.1 shall be those used to describe the navigational elements and parameters listed in *IEC Publication 1174*. The requirement applies also to RCDS.

5.7.19.9.3 SENC information, when displayed at the scale specified in the ENC, shall use the specified size of symbols, figures and letters prescribed in *Publications: IHO S-52* and *IEC 1174*. The requirement does not apply to RCDS.

5.7.19.9.4 ECDIS shall allow the mariner to select whether own ship is displayed in true scale or as a symbol. The requirement applies also to RCDS.

5.7.19.10 Route planning

5.7.19.10.1 It shall be possible to carry out route planning and route monitoring in a simple and reliable manner. The requirement applies also to RCDS..

5.7.19.10.2 The largest scale data available in the SENC for the area given shall always be used by the ECDIS for all alarms or indications of crossing the ship's safety contour and of entering a prohibited area, and for other alarms and indications. The requirement does not apply to RCDS.

5.7.19.10.3 It shall be possible to carry out route planning including both straight and curved segments. The requirement applies also to RCDS.

5.7.19.10.4 It shall be possible to adjust a planned route by:

- .1** adding waypoints to a route;
- .2** deleting waypoints from a route;
- .3** changing the position of a waypoint;
- .4** changing the order of the waypoints in the route..

The requirement applies also to RCDS

5.7.19.10.5 It shall be possible to plan an alternative route in addition to the selected route. The selected route shall be clearly distinguishable from the other routes. The requirement applies also to RCDS

5.7.19.10.6 An ECDIS indication is required if the mariner plans a route across an own ship's safety contour. The requirement does not apply to RCDS.

5.7.19.10.7 An ECDIS indication is required if the mariner plans a route across the boundary of a prohibited area or of a geographical area for which special conditions exist. The requirement does not apply to RCDS.

5.7.19.10.8 It shall be possible for the mariner to specify a limit of deviation from the planned route at which activation of an automatic off-track alarm shall occur. The requirement applies also to RCDS

5.7.19.10.9 For RCDS it shall be possible for the mariner to enter points, lines and areas which activate an automatic alarm. The display of these features shall not degrade the SRNC information and it shall be clearly distinguishable from the SRNC information.

5.7.19.11 Route monitoring

5.7.19.11.1 For route monitoring the selected route and own ship's position shall appear whenever the display covers that area. The requirement applies also to RCDS.

5.7.19.11.2 It shall be possible to display a sea area that does not have the ship on the display (e.g., for look ahead, route planning), while route monitoring. If this is done on the display used for route monitoring, the automatic route monitoring functions shall be continuous. In the case of ECDIS it can be e.g. updating ship's position, and providing alarms and indications. In the case of RCDS it concerns functions described in 5.7.19.10.8 i 5.7.19.10.9. It shall be possible to return to the route monitoring display covering own ship's position immediately by single operator action.

5.7.19.11.3 ECDIS shall give an alarm if the ship, within a specified time set by the mariner, is going to cross the safety contour. The requirement does not apply to RCDS.

5.7.19.11.4 ECDIS shall give an alarm or indication, as selected by the mariner, if the ship, within a specified time set by the mariner, is going to cross the boundary of a prohibited area or of a geographical area for which special conditions exist. The requirement does not apply to RCDS.

5.7.19.11.5 An alarm shall be given when the specified limit for deviation from the planned route is exceeded. The requirement applies also to RCDS.

5.7.19.11.6 The ship's position shall be derived from a continuous positioning system of an accuracy consistent with the requirements of safe navigation. Whenever possible, a second independent positioning method of a different type shall be provided; ECDIS shall be capable of identifying discrepancies between the two systems. The requirement applies also to RCDS.

5.7.19.11.7 ECDIS shall provide an indication when the input from the position-fixing system is lost. ECDIS shall also repeat, but only as an indication, any alarm or indication passed to it from a position-fixing system. The requirement applies also to RCDS.

5.7.19.11.8 An alarm shall be given by ECDIS if the ship, within a specified time or distance set by the mariner, is going to reach a critical point on the planned route. The requirement applies also to RCDS.

5.7.19.11.9 The positioning system and the SENC shall be on the same geodetic datum. ECDIS shall give an alarm if this is not the case. The RCDS shall only accept data referenced to the WGS-84 or PE-90 geodetic data. RCDS shall give an alarm if the positional data is not referenced to one of these data.

5.7.19.11.10 It shall be possible to display an alternative route in addition to the selected route. The selected route shall be clearly distinguishable from the other routes. During the voyage, it shall be possible for the mariner to modify the selected sailing route or change to an alternative route. The requirement applies also to RCDS.

5.7.19.11.11 It shall be possible to display:

- .1** time-labels along ship's track, manually on demand and automatically at intervals selected between 1 and 120 m; and
- .2** an adequate number of: points, free movable electronic bearing lines, variable and fixed-range markers and other symbols required for navigation purposes and specified in *IEC Publication 1174*.

The requirement applies also to RCDS.

5.7.19.11.12 It shall be possible to enter the geographical co-ordinates of any position and then display that position on demand. It shall also be possible to select any point (features, symbol or position) on the display and to read its geographical co-ordinates on demand. The requirement applies also to RCDS.

5.7.19.11.13 It shall be possible to adjust the ship's geographical position manually. This manual adjustment shall be noted alpha-numerically on the screen, maintained until altered by the mariner, and automatically recorded. The requirement applies also to RCDS.

5.7.19.11.14 It shall be possible to adjust by RCDS the ship's geographical position manually.

5.7.19.11.15 It shall be possible to activate by RCDS an automatic alarm when the ship crosses a point, line, or is within the boundary of a mariner-entered feature within a specified time or distance.

5.7.19.12 Voyage recording

5.7.19.12.1 ECDIS shall store and be able to reproduce certain minimum elements required to reconstruct the navigation and verify the official database used during the previous 12 hours. The following data shall be recorded at one-minute intervals:

- .1** to ensure a record of own ship's past track: time, position, heading, and speed; and

- .2 to ensure a record of official data used: ENC source, edition, date, cell and update history.

The requirement applies also to RCDS.

5.7.19.12.2 In addition, ECDIS shall record the complete track for the entire voyage, with time marks at intervals not exceeding 4 hours. The requirement applies also to RCDS.

5.7.19.12.3 It shall not be possible to manipulate or change the recorded information. Wymaganie dotyczy również RCDS.

5.7.19.12.4 ECDIS shall have the capability to preserve the record of the previous 12 hours and of the voyage track. The requirement applies also to RCDS.

5.7.19.13 Accuracy

5.7.19.13.1 The accuracy of all calculations performed by ECDIS shall be independent of the characteristics of the output device and shall be consistent with the SENC accuracy. The requirement applies also to RCDS.

5.7.19.13.2 Bearings and distances drawn on the display, or those measured between features already drawn on the display, shall have an accuracy no less than that afforded by the resolution of the display. The requirement applies also to RCDS.

5.7.19.14 Connections with other equipment⁵

5.7.19.14.1 ECDIS shall not degrade the performance of any equipment providing sensor inputs. Nor shall the connection of optional equipment degrade the performance of ECDIS below this standard. The requirement applies also to RCDS.

5.7.19.14.2 ECDIS shall be connected to systems providing continuous position-fixing, heading and speed information. The requirement applies also to RCDS.

5.7.19.15 Performance tests, malfunction alarms and indications

5.7.19.15.1 ECDIS shall be provided with means for carrying out on-board tests of major functions either automatically or manually. In case of a failure, the test shall display information to indicate which module is at fault. The requirement applies also to RCDS.

5.7.19.15.2 ECDIS shall provide a suitable alarm or indication of system malfunction. The requirement applies also to RCDS.

5.7.19.16 Power supply

Changing from one source of power supply to another, or any interruption of the supply for a period of up to 45 s, shall not require the equipment to be re-initialized manually. The requirement applies also to RCDS.

⁵ See IEC Publication 1162

5.7.20 Back-Up ECDIS/RCDS arrangements (*acc. to Res.MSC.64(67)*)

5.7.20.1 Adequate back-up arrangements shall be provided to ensure safe navigation in case of an ECDIS/RCDS failure.

5.7.20.2 The back-up system shall display in graphical (chart) form the relevant information of the hydrographic and geographic environment which are necessary for safe navigation.

5.7.20.3 The back-up system shall be capable of performing the route planning functions, including:

taking over of the route plan originally performed on the ECDIS/RCDS;
adjusting a planned route manually or by transfer from a route planning device.

5.7.20.4 The back-up system shall enable a take-over of the route monitoring originally performed by the ECDIS/RCDS, and provide at least the following functions:

- plotting own ship's position automatically, or manually on a chart;
- taking courses, distances and bearings from the chart;
- displaying the planned route;
- displaying time labels along ship's track;
- plotting an adequate number of points, bearing lines, range markers, etc., on the chart.

5.7.20.5 If the back-up is an electronic device, it shall be capable of displaying at least the information equivalent to the standard display as defined in this performance standard

5.7.20.6 The chart information to be used shall be:

the latest editions of that originated by a government hydrographic office, and based on IHO standards;

it shall not be possible to alter the contents of the electronic chart information;

the chart or chart data edition and issuing date shall be indicated.

5.7.20.7 The information displayed by the ECDIS/RCDS back-up arrangements shall be up-to-date for the entire voyage..

5.7.20.8 If an electronic device is used, it shall provide an indication:

- if the information is displayed at a larger scale than that contained in the database; and
- if own ship's position is covered by a chart at a larger scale than that provided by the system..

5.7.20.9 If radar and other navigational information are added to an electronic back-up display, all the corresponding to requirements of this performance standard corresponding to ECDIS information display shall be met.

5.7.20.10 If an electronic device is used, the display mode and generation of the neighbouring area shall be in accordance with section 5.7.19.8.1÷4 of this performance standard.

5.7.20.11 The back-up arrangements shall be able to keep a record of the ship's actual track, including positions and corresponding times.

5.7.20.12 Accuracy shall be in accordance with section 5.7.19.13 of this performance standard.

5.7.20.13 If an electronic device is used, it shall provide a suitable indication of system malfunction..

5.7.20.14 Colours and symbols used in the back-up arrangements shall be based on IHO recommendations.

5.7.20.15 If an electronic device is used, the effective size of the chart presentation shall be in, as for ECDIS/RCDS, at least 270 mm/270 mm.

5.7.20.16 If an electronic device connected with other equipment is used, it shall:

- be connected to systems providing continuous position-fixing capability;
- not degrade the performance of any equipment providing sensor input;
- if radar with selected parts of the ENC chart information overlay is used as an element of the back-up, the radar shall comply with the requirements of 5.7.14.

5.7.20.17 The back-up power supply shall be separate from the ECDIS/RCDS, and changing from one source of power supply to another, or any interruption of the supply for a period of up to 45 s, shall not require the equipment to be re-initialized manually.

5.7.21 Naval electronic charts display and information system WECDIS

5.7.21.1 Naval version of ECDIS is WECDIS, made in accordance with STANAG 4564. It is a device meeting all of the above criteria for ECDIS, which also enables operation of the Additional Military Layers (AML), made in accordance with STANAG 7170.

These devices are necessary to protect naval forces and are treated as the main navigation equipment for NATO ships, therefore, all NATO naval ships shall be equipped with WECDIS.

5.7.22 Daylight signalling lamp (*acc. to Res. MSC.96(72)*) ????????????

Wymagania techniczno-eksploatacyjne dla lampy sygnalizacji dziennej określono w rozdziale 6.

5.7.23 Global positioning system (GPS) receiver ¹⁾
(acc. to Res.A.819(19), Res.MSC.112(73))

5.7.23.1 Introduction

5.7.23.1.1 Global positioning system GPS operates using two frequencies in *L* band: $L_1=1575,42$ MHz i $L_2=1227,60$ MHz.

5.7.23.1.2 Receiver equipment for the GPS is intended for navigational purposes on ships with maximum speeds not exceeding 70 knots.

5.7.23.2 Performance standard

5.7.23.2.1 The GPS receiver equipment shall:

- .1 be capable of receiving and processing the Standard Positioning Service (SPS) signals as modified by Selective Availability (SA) and provide position information in latitude and longitude World Geodetic System (WGS) 84 coordinates in degrees, minutes and thousandths of minutes and time of solution referenced to UTC. Means may be provided for transforming the computed position based upon WGS 84 into data compatible with the datum of the navigational chart in use. Where this facility exists, the display shall indicate that co-ordinate conversion is being performed, and shall identify the co-ordinate system in which the position is expressed;
- .2 operate on the L1 signal and C/A code;
- .3 be provided with at least one output from which position information can be supplied to other equipment. The output of position information based upon WGS 84 shall be in accordance with *IEC Publication 1162*;
- .4 have static accuracy such that the position of the antenna is determined to within 100 m (95%) with horizontal dilution of precision (HDOP) ≤ 4 (or PDOP ≤ 6);
- .5 have dynamic accuracy such that the position of the ship is determined to within 100 m (95%) with HDOP ≤ 4 (or PDOP ≤ 6) under the conditions of sea states and ship's motion likely to be experienced in ships;¹⁾
- .6 be capable of selecting automatically the appropriate satellite-transmitted signals for determining the ship's position with the required accuracy and update rate;
- .7 be capable of acquiring satellite signals with input signals having carrier levels in the range of -130 dBm to -120 dBm. Once the satellite signals have been acquired, the equipment shall continue to operate satisfactorily with satellite signals having carrier levels down to -133 dBm
- .8 be capable of acquiring position to the required accuracy within 30 min when there is no valid almanac data;

¹⁾ Applies to receivers installed from 01.07.2003.

¹⁾ See: *Publications IEC 6721-3-6, IEC 60945, IEC 61108-1 and Resolution A.694(17)*

- .9 be capable of acquiring position to the required accuracy within 5 min when there is valid almanac data;
- .10 be capable of re-acquiring position to the required accuracy within 5 min when the GPS signals are interrupted for a period of at least 24 h but there is no loss of power;
- .11 be capable of re-acquiring position to the required accuracy within 2 min when subjected to a power interruption of 60 s;
- .12 generate and output to a display and digital interface (conforming to *IEC Publication 61162*) a new position solution at least once every 1 s;⁶⁾;
- .13 the minimum resolution of position, i.e. latitude and longitude, shall be 0.001 minutes;
- .14 generate and output to the digital interface, conforming to *IEC Publication 61162*, course over the ground (COG), speed over the ground (SOG) and universal time co-ordinated (UTC). Such outputs shall have a validity mark aligned with that on the position output. The accuracy requirement for COG and SOG shall not be inferior to those prescribed in 5.7.10.3.5 and 5.7.11.3;
- .15 have the facilities to process differential GPS (DGPS) data fed to it in accordance with the standards of Recommendation ITU-R M.823 and the appropriate *RTCM Publications*. When a GPS receiver is equipped with a differential receiver, performance standards for static and dynamic accuracies (see 5.7.23.2.1.4 and 5.7.23.2.1.5 above) shall be 10 m (95%);
- .16 be capable of operating satisfactorily in typical interference conditions.

5.7.23.3 Protection

Precautions shall be taken to ensure that no permanent damage can result from an accidental short circuit or grounding of the antenna or any of its input or output connections or any of the GPS receiver equipment inputs or outputs for a duration of 5 min

5.7.23.4 Failure warnings and status indications

5.7.23.4.1 The equipment shall provide an indication of whether the position calculated is likely to be outside the requirements of these performance standards.

5.7.23.4.2 The GPS receiver equipment shall provide as a minimum an indication within 5 s if either: the specified HDOP has been exceeded; or a new position has not been calculated for more than 1 s.⁷

Under such conditions the last known position and the time of the last valid fix, with explicit indication of this state, so that no ambiguity can exist, shall be output until normal operation is resumed.

5.7.23.4.3 Receiver shall be capable of signalling a loss of position.

⁶⁾ For craft meeting the HSC Code, a new position solution at least every 0.5 s is recommended.

⁷ Applies to receivers installed from 1 July 2003

5.7.23.4.4 Receiver shall be capable signalling differential GPS status indication of the receipt of DGPS signals and whether DGPS corrections are being applied to the indicated ship's position..

5.7.23.4.5 Receiver shall be capable of indicating DGPS integrity status and alarming in the case of its loss.

5.7.23.4.6 Receiver shall be capable of DGPS text message display.

5.7.24 Combined Global positioning system (GPS)/Global navigation satellite system (GLONASS) (*acc. to Res. MSC.74(69), Res.MSC.115(73)*)

5.7.24.1 Introduction

GPS/GLONASS receiver is intended ships with maximum speeds not exceeding 70 knots.

5.7.24.2 General GPS/GLONASS requirements

The equipment shall include:

- .1 antenna capable of receiving both GPS and GLONASS signals;
- .2 combined GPS/GLONASS receiver and processor;
- .3 means of accessing the computed latitude/longitude position;
- .4 data control and interface; and
- .5 position display.

5.7.24.3 Wymagania techniczne dotyczące uniwersalnego odbiornika GPS/GLONASS

Odbiornik GPS/GLONASS powinien:

- .1 be capable of receiving and processing the Standard Positioning Service (SPS) signals of the GPS as modified by Selective Availability (SA) and range code signals in GLONASS and provide position information in latitude and longitude World Geodetic System (WGS) 84 co-ordinates in degrees, minutes and thousandths of minutes. Means may be provided to transform the computed position into data compatible with the datum of the navigational chart in use. Where this facility exists, the display and any data output shall indicate that the co-ordinate conversation is being performed and shall identify the co-ordinate system in which the position is expressed;
- .2 operate on the L1 frequency signal and C/A code in GPS and L1 frequency signal and range code in GLONASS;
- .3 be provided with at least one output from which position information can be supplied to other equipment. The output of position information shall be in accordance with the *IEC Publication 1162*;
- .4 have static accuracy such that the position of the antenna is determined to within 35 m (95%) in non-differential mode and 10 m (95%) in differential mode with horizontal dilution of precision (HDOP) ≤ 4 or position dilution of precision (PDOP) ≤ 6 ;

- .5 have dynamic accuracy such that the position of the ship is determined to within 35 m (95%) in non-differential mode and ≤ 10 m (95%) in differential mode with HDOP ≤ 4 or PDOP ≤ 6 under the conditions of sea states and ship's motion likely to be experienced in ships; ¹⁾;
- .6 be capable of selecting automatically the appropriate satellite transmitted signals for determination of the ship's position with the required accuracy and update rate;
- .7 be capable of acquiring satellite signals with input signals having carrier levels in the range of -130 dBm to -120 dBm. Once the satellite signals have been acquired the equipment shall continue to operate satisfactorily with satellite signals having carrier levels down to -133 dBm;
- .8 be capable of acquiring position to the required accuracy, within 30 min, when there is no valid almanac data;
- .9 be capable of acquiring position to the required accuracy, within 5 min, when there is valid almanac data;
- .10 be capable of re-acquiring position to the required accuracy, within 5 min, when all GPS and GLONASS signals are interrupted for a period of at least 24 h, but there is no loss of power;
- .11 be capable of re-acquiring position to the required accuracy, within 2 min, when subjected to a power interruption of 60 s;
- .12 be capable of re-acquiring an individual satellite signal and utilizing it in the position solution within 10 s after being blocked for 30 s;
- .13 generate and output to a display and digital interface, conforming with *IEC Publication 61162*, a new position solution at least once every 1 s;
- .14 have a minimum resolution of position, i.e. latitude and longitude of 0.001 minutes;
- .15 generate output to the digital interface, conforming with *IEC Publication 61162*, course over the ground (COG), speed over the ground (SOG) and universal time co-ordinated (UTC). Such outputs shall have a validity mark aligned with that on the position output. The accuracy requirement for COG and SOG shall not be inferior to those described in 5.7.10.3.5 and 5.7.11.3;t
- .16 have the facilities to process DGPS and DGLONASS data fed to it, in accordance with Recommendation ITU-R M.823 and the appropriate RTCM *Publications*;
- .17 be capable of operating satisfactorily in typical interference conditions.

5.7.24.4 Protection

Precautions shall be taken to ensure that no permanent damage can result from an accidental short circuit or grounding of the antenna or any of its input or output connections or any of the combined GPS/GLONASS receiver equipment inputs or outputs for a duration of 5 min.

¹⁾ See: *IEC Publications 6721-3-6, IEC 60945, IEC 61108-1 and Resolution A.694(17)*

5.7.24.5 Indications status

5.7.24.5.1 The equipment shall provide an indication if the position calculated is likely to be outside of the requirements of these performance standards.

5.7.24.5.2 The combined GPS/GLONASS receiver equipment shall provide as a minimum an indication within 5 s if either the specified HDOP has been exceeded; or a new position has not been calculated for more than 1 s.

Under such conditions the last known position and the time of the last valid fix, with explicit indication of this state, so that no ambiguity can exist, shall be output until normal operation is resumed.

5.7.24.5.3 Receiver equipment shall provide a warning of loss of position

5.7.24.5.4 Receiver equipment shall provide DGPS and DGLONASS status indication of the receipt of DGPS and DGLONASS signals; and whether DGPS and DGLONASS corrections are being applied to the indicated ship's position.

5.7.24.5.5 Receiver equipment shall provide an indication on DGPS and DGLONASS integrity status and alarm on its absence.

5.7.24.5.6 The receiver shall be capable of DGPS and DGLONASS text message display.

5.7.25 Radio beacon receivers of the Differential Global Positioning System (DGPS) and the Differential Global Navigation Satellite System (DGLONASS) (*acc. to Res.MSC.64(67), Res.MSC.114(73)*¹⁾)

5.7.25.1 Introduction

Radio beacon receivers of DGPS and DGLONASS systems are intended for ships of speed not exceeding 70 knots.

5.7.25.2 Requirements

DGPS and DGLONASS radio beacon receiver shall:

- .1 operate in the band of 283.5 to 315 kHz in Region 1 and 285 to 325 kHz in Regions 2 and 3 in accordance with ITU-R M.823;
- .2 provide means of automatically and manually selecting the frequency;
- .3 make the data available for use with a delay not exceeding 100 ms after its reception;
- .4 be capable of acquiring a signal in less than 45 seconds in the presence of electrical storms;
- .5 have at least one serial data output that conforms to the requirements of *IEC Publication 1162* concerning international marine interface;
- .6 have an omni-directional antenna in the horizontal plane;
- .7 operate satisfactorily in typical interference conditions.

¹⁾ Applies to receivers installed in ships from 1 July 2003.

5.7.25.3 Resistance to electrical damages

Precautions shall be taken to ensure that no permanent damage can result from an accidental short circuit or grounding of the antenna or any of its input or output connections for a duration of five minutes.

5.7.26 Automatic identification system AIS (*acc. to Res. MSC.74(69)*)

5.7.26.1 Designation

5.7.26.1.1 The AIS task is to improve the safety of navigation by assisting in the efficient navigation of ships, protection of the environment, and operation of Vessel Traffic Services (VTS). AIS shall satisfy the following functional requirements:

- .1 in a ship-to-ship mode for collision avoidance;
- .2 as a means for littoral States to obtain information about a ship and its cargo; and
- .3 as a VTS tool, i.e. ship-to-shore (traffic management).

5.7.26.1.2 The AIS shall be capable of providing to ships and to competent authorities, information from the ship, automatically and with the required accuracy and frequency, to facilitate accurate tracking. Transmission of the data shall be with the minimum involvement of ship's personnel and with a high level of availability.

5.7.26.1.3 The installation, in addition to meeting the requirements of the *Radio Regulations*, ITU-R recommendations M.1371-1, and the general requirements as set out sub-chapter 5.7.1, AIS shall comply with the performance standards presented in further part of the sub-chapter 5.7.26.

5.7.26.2 Performance standards

5.7.26.2.1 AIS system shall be capable of operating in a following modes:

- .1 an "autonomous and continuous" mode for operation in all areas;
- .2 an "assigned" mode for operation in an area subject to a competent authority responsible for traffic monitoring such that the data transmission interval and/or time slots may be set remotely by that authority;
- .3 a "polling" or controlled mode where the data transfer occurs in response to interrogation from a ship or competent authority.

5.7.26.2.2 The system shall provide for changing over, by the competent authority, any of the listed in 5.7.26.2.1 mode (under operation) to any of the remaining.

5.7.26.3 Structure and capability

5.7.26.3.1 The AIS shall comprise:

- .1 a communication processor, capable of operating over a range of maritime frequencies, with an appropriate channel selecting and switching method, in support of both short and long range applications;

- .2 a means of processing data from an electronic position-fixing system which provides a resolution of 1/10 000 of a minute of arc and uses the WGS-84 datum;
- .3 a means to automatically input data from other sensors meeting the provisions as specified in paragraph 5.7.26.7;
- .4 a means to input and retrieve data manually;;
- .5 a means of error checking the transmitted and received data;
- .6 built in test equipment.

5.7.26.3.2 The AIS shall be capable of:

- .1 providing information automatically and continuously to a competent authority and other ships, without involvement of ship's personnel;
- .2 receiving and processing information from other sources, including that from a competent authority and from other ships;
- .3 responding to high priority and safety related calls with a minimum of delay;
- .4 providing positional and maneuvering information at a data rate adequate to facilitate accurate tracking by a competent authority and other ships.

5.7.26.4 User interface

To enable a user to access, select and display the information on a separate system, the AIS shall be provided with an interface conforming to an appropriate international marine interface standard., described in *IEC Publication 61162*.

5.7.26.5 Identification

For the purpose of ship and message identification, the appropriate Maritime Mobile Service Identity (MMSI) number shall be used.

5.7.26.6 Information provided by AIS

The information provided by the AIS shall include:

- .1 Static information:
 - IMO number;
 - call sign & name;
 - length and beam;
 - type of ship;
 - location of position-fixing antenna on the ship (aft of bow and port or starboard of centerline)
- .2 Dynamic information:
 - ship's position with accuracy indication and integrity status;
 - time in UTC (the date determined by the receiving device);
 - course over ground;
 - speed over ground;
 - heading;

- navigational status (e.g. NUC, at anchor, etc. - manual input)
 - rate of turn (where available)
 - optional - angle of heel (where available, data field not available in a basic message);
 - optional - pitch and roll (where available, data field not available in a basic message);
- .3** Voyage related information:
- ship's draught;
 - hazardous cargo (type) – in accordance with the competent authority requirements;
 - destination and ETA (at masters discretion);
 - optional - route plan (waypoints, data field not available in a basic message);
- .4** Short safety-related messages.

5.7.26.7 Information update rates for autonomous mode

5.7.26.7.1 The different information types are valid for a different time period and thus need a different update rate:

- static information: every 6 min and on request;
- dynamic information: dependant on speed and course alteration – according to Table 1 5.7.26.7.1;
- voyage related information: every 6 min, when data has been amended and on request;
- safety-related message: as required

Table 5.7.26.7.1
Data update rate depending
on speed and change of course

Ship motion data	Update rate
at anchor	3 min
speed 0-14 knots	12 s
speed 0-14 knots and changing course	4 s
speed 14-23 knots	6 s
speed 14-23 knots and changing course	2 s
speed higher than 23 knots	3 s
speed higher than 23 and changing course	2 s

5.7.26.7.2 Ship Reporting Capacity - the system shall be able to handle a minimum of 2000 reports per min to adequately provide for all operational scenarios envisioned.

5.7.26.8 Security

A security mechanism shall be provided to detect disabling and to prevent unauthorised alteration of input or transmitted data.

5.7.26.9 Permissible initialization period

The installation shall be operational within 2 min of switching on.

5.7.26.10 Technical characteristics

The technical characteristics of the AIS such as variable transmitter output power, operating frequencies (dedicated internationally and selected regionally), modulation, and antenna system shall comply with the appropriate ITU-R Recommendations.M.1371-1.

5.7.27 Voyage data recorded (VDR) (acc. to Res. A.861(20))

5.7.27.1 Introduction

The purpose of a voyage data recorder (VDR) is to maintain a store, in a secure and retrievable form, of information concerning the position, movement, physical status, command and control of a vessel over the period leading up to and following an incident.

5.7.27.2 General

5.7.27.2.1 The VDR shall continuously maintain sequential records of pre-selected data items relating to the status and output of the ship's equipment, and command and control of the ship, referred to in 5.7.27.5.

5.7.27.2.2 To permit subsequent analysis of factors surrounding an incident, the method of recording shall ensure that the various data items can be co-related in date and time during playback.

5.7.27.2.3 The final recording medium shall be installed in a protective capsule which shall:

- .1** be capable of being accessed following an incident but secure against tampering;
- .2** maximize the probability of survival and recovery of the final recorded data after any incident;
- .3** be of a highly visible colour and marked with retro-reflective materials;
- .4** be fitted with an appropriate device to aid location.

5.7.27.2.4 The design and construction, which shall be in accordance with the requirements sub-chapter 5.7 and *IEC 60945 Publication*, shall take special account of the requirements for data security and continuity of operation as detailed in 5.7.27.3 i 5.7.27.4.

5.7.27.3 Data selection and security

5.7.27.3.1 The minimum selections of data items to be recorded by the VDR are specified in 5.7.27.5. Optionally, additional items may be recorded provided that the requirements for the recording and storage of the specified selections are not compromised.

5.7.27.3.2 The equipment shall be so designed that, as far as is practical, it is not possible to tamper with the selection of data being input to the equipment, the data itself nor that which has already been recorded. Any attempt to interfere with the integrity of the data or the recording shall be recorded.

5.7.27.3.3 The recording method shall be such that each item of the recorded data is checked for integrity and an alarm given if a non-correctable error is detected.

5.7.27.4 Continuity of operation

5.7.27.4.1 To ensure that the VDR continues to record events during an incident, it shall be capable of operating from the ship's emergency source of electrical power.

5.7.27.4.2 If the ship's emergency source of electrical power supply fails, the VDR shall continue to record Bridge Audio from a dedicated reserve source of power for a period of 2 h. At the end of this 2 h period all recording shall cease automatically.

5.7.27.4.3 Recording shall be continuous unless interrupted briefly in accordance with 5.7.27.6 or terminated in accordance with 5.7.27.4.2. The time for which all stored data items are retained shall be at least 12 h. Data items which are older than this may be overwritten with new data.

5.7.27.5 Data items to be recorded

5.7.27.5.1 Date and time

Date and time, referenced to UTC, shall be obtained from a source external to the ship or from an internal clock. The recording shall indicate which source is in use. The recording method shall be such that the timing of all other recorded data items can be derived on playback with a resolution sufficient to reconstruct the history of the incident in detail.

5.7.27.5.2 Ship's position

Latitude and longitude, and the datum used, shall be derived from an electronic position-fixing system (EPFS). The recording shall ensure that the identity and status of the EPFS can always be determined on playback.

5.7.27.5.3 Speed

Speed through the water or speed over the ground, including an indication of which it is, derived from the ship's speed and distance measuring equipment

5.7.27.5.4 Heading

The ship's heading as indicated by the ship's compass shall be recorded.

5.7.27.5.5 Bridge Audio

One or more microphones positioned on the bridge shall be placed so that conversation at or near the conning stations, radar displays, chart tables, etc., are adequately recorded. As far as practicable, the positioning of microphones shall also capture intercom, public address systems and audible alarms on the bridge.

5.7.27.5.6 Communications Audio

VHF communications relating to ship operations shall be recorded.

5.7.27.5.7 Radar data, post-display selection

This shall include electronic signal information from within one of the ship's radar installations which records all the information which was actually being presented on the master display of that radar at the time of recording. This shall include any range rings or markers, bearing markers, electronic plotting symbols, radar maps, whatever parts of the SENC or other electronic chart or map that were selected, the voyage plan, navigational data, navigational alarms and the radar status data that were visible on the display. The recording method shall be such that, on playback, it is possible to present a faithful replica of the entire radar display that was on view at the time of recording, albeit within the limitations of any bandwidth compression techniques that are essential to the working of the VDR.

5.7.27.5.8 Echo-sounder

This shall include depth under keel, the depth scale currently being displayed and other status information where available.

5.7.27.5.9 Main alarms

This shall include the status of all mandatory alarms on the bridge.

5.7.27.5.10 Rudder order and response

This shall include, besides of rudder orders and responses, status and settings of auto-pilot, if fitted.

5.7.27.5.11 Engine order and response

This shall include the positions of any engine telegraphs or direct engine/propeller controls and feedback indications, if fitted, including ahead/astern indicators. This shall also include status of bow thrusters if fitted.

5.7.27.5.12 Hull openings status

This shall include all mandatory status information required to be displayed on the bridge.

5.7.27.5.13 Watertight and fire door status

This shall include all mandatory status information required to be displayed on the bridge.

5.7.27.5.14 Accelerations and hull stresses

Where a ship is fitted with hull stress and response monitoring equipment, all the data items that have been pre-selected within that equipment shall be recorded.

5.7.27.5.15 Wind speed and direction

This shall be applicable where a ship is fitted with a suitable sensor. Either relative or true wind speed and direction may be recorded, but an indication of which it is shall be recorded.

5.7.27.6 Operation

The unit shall be entirely automatic in normal operation. Means shall be provided whereby recorded data may be saved by an appropriate method following an incident, with minimal interruption to the recording process.

5.7.27.7 Interfacing

Interfacing to the various sensors required shall be in accordance with the relevant international interface standard, where possible. Any connection to any item of the ship's equipment shall be such that the operation of that equipment suffers no deterioration, even if the VDR system develops faults.

5.7.28 Obtaining and transmitting magnetic heading device (TMHD) (acc. to Res. MSC.86(70))

5.7.28.1 Introduction

A TMHD is an electronic device which uses the geomagnetic field to obtain and transmit to co-operating devices information about the ship's heading.

5.7.28.2 Composition

Transmitting magnetic heading devices (TMHD) may comprise of:

- .1** a standard magnetic compass equipped with a magnetic sensor and electronics for generating a suitable output signal for other devices. The compass used shall be the standard magnetic compass provided under 5.4.2; or
- .2** an electromagnetic compass consisting of the sensor part and electronics for generating a suitable output signal for other devices; or
- .3** any type as defined under .1 and .2, additionally equipped with a rate gyro to improve dynamic performance.

5.7.28.3 Construction

A fore-and-aft mark shall be inscribed on the magnetic sensor housing. The accuracy of the fore-and-aft mark shall be within $\pm 0.5^\circ$ to the fore-and-aft direction of the housing.

5.7.28.3.1 Provision shall be made, in the mounting arrangements of the magnetic sensor, for correction of any misalignment, up to $\pm 5^\circ$, with respect to the fore-and-aft line.

5.7.28.3.2 The fitting of the sensor arrangement to the magnetic compass shall still enable the compass to comply with the requirements described in sub-chapter 5.7.9.

5.7.28.3.3 A rate gyro shall be marked in the same way as magnetic sensor casing and, additionally, be marked with top or bottom.

5.7.28.4 Compensation of deviation and heeling error of the compass rose

5.7.28.4.1 Provision shall be made to correct the deviation and heeling error of the compass rose. It shall be possible to correct the following values:

- .1 vertical component of the ship's magnetic field (producing the heeling error): up to $\pm 75 \mu\text{T}$;
- .2 coefficient A: up to $\pm 3^\circ$;
- .3 coefficient B: up to $\pm(720/H)^\circ$;
- .4 coefficient C: up to $\pm(720/H)^\circ$;
- .5 coefficient D: up to $\pm 7^\circ$;
- .6 coefficient E: up to $\pm 3^\circ$;

where H is the horizontal component of the geomagnetic flux density in μT .

5.7.28.4.2 The values used for electronic compensation shall be indicated by adequate means and shall be stored such that values are automatically recovered on switch-on.

5.7.28.4.3 The compensating devices shall be protected against inadvertent operation.

5.7.28.5 Heading output

5.7.28.5.1 All displays and outputs of heading shall indicate true heading. An indication of any deviation and variation applied to compensate the heading shall be capable of being displayed or included in the output.

5.7.28.5.2 The TMHD shall be so designed to transmit heading information to other equipment. At least one output shall be in accordance with the relevant international marine interface standard described in *IEC 61162 Publication*.

5.7.28.6 Właściwości

5.7.28.6.1 The following accuracy of heading is required to be achieved by TMHD (under the conditions of a value of 18 μT of the horizontal component of the geomagnetic field and the environmental conditions experienced on board ships):

- .1 static accuracy – $\pm 1^\circ$,
- .2 dynamic accuracy – $\pm 1,5^\circ$ in addition to the static accuracy as defined. Periods of oscillation of the error should not be shorter than 30 s under the conditions of various sea states and ship's motion.

5.7.28.6.2 The follow-up accuracy of the transmission system should be within $\pm 1.5^\circ$, when the sensor is rotated at a rate of $20^\circ/\text{s}$.

5.7.28.7 Electromagnetic compatibility

With regard to electromagnetic interference and immunity, the compass system in addition to the requirements of Res. A.694 (17) shall meet the requirements of Res. A.813 (19).

5.7.28.8 Alarmy

An alarm should be provided to indicate a failure of the power supply to the system.

5.7.29 Transmitting heading device (THD) (*acc. to Res. MSC.116(73)*)

5.7.29.1 Introduction

5.7.29.1.1 A transmitting heading device (THD) is an electronic device, which provides information about the ship's true heading. The THD receives a heading signal and generates a suitable output signal for other devices.

5.7.29.1.2 If the performance standards which apply to the sensing part do not specify a geographical operating area the THD shall operate from 70° latitude south to 70° latitude north as minimum.

5.7.29.1.3 Any correcting devices or parameters should be protected against inadvertent operation and inadvertent change of parameters.

5.7.29.2 Output heading signal

5.7.29.2.1 All displays, and all outputs of heading shall indicate true heading. Manually settable values used for electronic correction should be indictable by adequate means.

5.7.29.2.2 At least one output heading signal shall comply with the international requirements for interfaces designated for marine equipment described in *IEC Publication 61162*.

5.7.29.3 Accuracy

The THD shall be tested for accuracy with the sensing part connected. The THD shall meet at least the following accuracy (under sea conditions as specified in 5.7.10.3.3):

- .1 transmission error including the resolution error – less than $\pm 0.2^\circ$;
- .2 static error – less than $\pm 1.0^\circ$;
- .3 dynamic error – less than $\pm 1.5^\circ$. The dynamic error frequency should be less than 0.033Hz (equivalent to a period not shorter than 30s) if the amplitude of the dynamic error exceeds $\pm 0.5^\circ$. If the heading sensing part is a magnetic sensor, it shall comply with the requirements of 5.7.9 and shall be tested separately for the compliance with that requirements;
- .4 follow-up error for different rates of turn shall be:
 - less than $\pm 0.5^\circ$ at rates up to 10o/s; and
 - less than $\pm 1.5^\circ$ between a rate of 10o/s to 20o/s.

5.7.29.4 Electromagnetic compatibility

With regard to electromagnetic interference and immunity, the THD device in addition to the requirements of Res. A.694 (17) shall meet the requirements of Res. A.813 (19) and *IEC Publication 60533*.

5.7.29.5 Alarms

An alarm should be provided to indicate a damage or failure of the power supply to the device.

5.7.30 System odbioru i wzmacniania dźwięków (*wg Rez. MSC.86(70)*)

5.7.30.1 Introduction

Sound reception and amplification systems are acoustical electronic navigational aids to enable the officer on the watch to hear outside sound signals inside a totally enclosed bridge.

5.7.30.2 Functional requirements

Sound reception and amplification systems should be capable of:

- .1 receiving sound signals from all directions in the audio band 70 Hz - 820 Hz;
- .2 reproducing incoming sound signals acoustically inside the bridge;
- .3 indicating the approximate direction of incoming sound signals to determine at least whether the sound signal being detected is forward or abaft of the beam and from which side of the ship. This may be accomplished by means of at least four microphones and separate reception channels;
- .4 suppressing unwanted background noise and allowing reception of meaningful sounds.

5.7.30.3 Method of presentation

5.7.30.3.1 Incoming sound signals should be reproduced inside the bridge by means of at least one loudspeaker.

5.7.30.3.2 The volume control should be capable of being set so that the sound pressure level of an incoming signal only is at least 10 dB(A) above the bridge noise level. The volume should be adjusted by means of one volume control only.

5.7.30.3.3 There should be a display which gives a visual indication for at least 3 seconds of the incoming signals and their approximate direction.

5.7.31 Device for heading or tracking steering (*acc. to Res. A.342(IX), Res. MSC.64(67), Res. MSC.74(69)*)

Technical-operational requirements for the heading or profile steering device are set down in *Part VIII – Electrical installations and control systems*.

6 REQUIREMENTS RELATING TO SOLAS CONVENTION, CHAPTER VI – CARRIAGE OF CARGO

6.1 General

6.1.1 Application

6.1.1.1 Requirements of chapter 6 apply to supply vessels and other ships carrying cargo units not constituting ships' stores.

6.2 Definitions

6.2.1 Cargo unit – a vehicle, container, flat, pallet, portable tank, packaged unit, or any other entity, etc., and loading equipment, or any part thereof, which belongs to the ship but is not fixed to the ship.

6.2.2 Portable securing devices – cargo stowage and lashing equipment intended for the stowage of cargo, such as lashings, tensioners, turnbuckles, stowage cones, stacking cones, bridge fittings, lashings, pulley blocks etc., not permanently connected to the ship's structure.

6.2.3 Permanent securing devices – arrangements for stowage and lashing of cargo such as deck sockets, lashing points, upright seats, etc., permanently connected to the ships structure.

6.2.4 Maximum securing load (MSL) is a term defining the allowable load capacity for a device used to secure the cargo on a ship. Maximum Securing Load is to be determined in accordance with the requirements specified in Table 6.2.4.

Table 6.2.4
Maximum Securing Load for specific securing devices

Securing devices	MSL
Shackles, rings, deck-eyes, tensioners, twist-locks, bridge fittings, stacking cones, lashing rods, lashing chains, etc.	50% of breaking load
Fibre ropes	33% of breaking load
Web lashings	70% of breaking load
Wire ropes (brand new)	80% of breaking load
Wire ropes (re-used)	30% of breaking load
Steel bands (brand new)	70% of breaking load
Chains	50% of breaking load

6.3 Technical Documentation

6.3.1 The complete set of technical documentation relevant to the object of this chapter 6, which is subject to approval by PRS, includes:

- .1 Stowage and lashing plan for containers giving their weight and the list of securing devices.
- .2 Lay-out plan of container sockets and lashing points.
- .3 Stowage and lashing plan for vehicles giving their weight and the list of the securing devices for vehicles.
- .4 Lay-out plan of sockets and lashing points for vehicles.
- .5 Stowage and lashing plan for cargo units other than containers and vehicles.

6.4 Scope of survey

6.4.1 The technical survey of PRS concerning the stowage and lashing equipment covers:

- .1 Assessment and approval of technical documentation.
- .2 Survey of manufacturing of portable securing devices and manufacturing and installation on board of permanent securing devices..
- .3 Surveys of stowage and securing devices.

6.4.2 The ship owner is responsible for maintenance of the adequate technical condition and current verification of the cargo securing devices.

6.4.3 PRS carries out annual, five-yearly surveys and occasional surveys of the fixed and portable securing devices. During surveys at least 1% of each kind of the securing devices, depending on its quantity on the ship, but no fewer than 10 items, are subject to visual inspection. If there is a likelihood of strength loss resulting from corrosion and/or wear-and tear, 0.5% of the securing devices are to be strength-tested.

6.5 General requirements for the stowage and securing devices

6.5.1 Every ship carrying cargo units shall be equipped with necessary number of stowage and securing means. By the necessary number of means it shall be understood provision the ship with adequate permanent and portable securing devices, securing cargo from shifting during transport to prevent damage to the hull structure or loss of the ship's stability.

6.5.2 For the cargo stowage and securing only fixtures specified in the list of the fixtures, included in the technical documentation approved by PRS.

6.5.3 Cargo stowage and securing permanent and portable devices are subject of PRS survey or approval after tests performed in accordance with the programme agreed with PRS.

6.5.4 Proof loads, Maximum Securing Loads and application of the test load to the essential securing devices are given in Table 6.5.4.

Table 6.5.4
Load application and load values for specific securing devices

No.	Device	Proof load	MSL	Notes
1	Lashing rod	1,1 <i>MSL</i>	0,5 <i>BL</i> **	
	Lashing chain	1,1 <i>MSL</i>	0,5 <i>BL</i>	
2	Turnbuckle*	1,1 <i>MSL</i>	0,5 <i>BL</i>	
3	Twistlock*	1,1 <i>MSL</i>	0,5 <i>BL</i>	Lecz nie mniej niż 250 kN
4	Single stacker	1,2 <i>MSL</i>	0,5 <i>BL</i>	
5	Double stacker	1,2 <i>MSL</i>	0,5 <i>BL</i>	
6	Bridge fitting*	250 kN	0,5 <i>BL</i>	Together with side fitting or corner fitting
7	Side fitting*	1,2 <i>MSL</i>	0,5 <i>BL</i>	Together with side socket
8	Penguin hook	1,1 <i>MSL</i>	0,5 <i>BL</i>	
9	Flush type deck fitting	1,2 <i>MSL</i>	0,5 <i>BL</i>	
10	Raised deck fitting	1,2 <i>MSL</i>	0,5 <i>BL</i>	
11	Dovetail type socket	1,2 <i>MSL</i>	0,5 <i>BL</i>	
12	„D-ring”	1,2 <i>MSL</i>	0,5 <i>BL</i>	
13	Lashing plate	1,2 <i>MSL</i>	0,5 <i>BL</i>	

* to be checked in operation after the test has been complete

** *BL* – breaking load

6.5.5 Around 2% of the products out of each batch submitted for approval are to be tested. Where the batch size is smaller than 50 items, at least one item is to be tested.

6.5.6 At least 2 to 5 per cent of the products out of each batch submitted for approval are to be checked in respect of workmanship and maintaining the allowable tolerances.

6.6 Stowing and securing of cargo units

6.6.1 General requirements and scope of application

6.6.1.1 The requirements of sub-chapter 6.6 apply to cargo units defined in 6.2.1, with exclusion of containers. Positioning and lashing of the containers is subject of separate PRS consideration.

6.6.1.2 All cargo units shall be stowed and secured in such a way that their shift, overturn, damage, etc. did not happen, as well as the ship structure's strength was not impaired.

6.6.1.3 Loads shall be arranged so as to ensure stability of the ship throughout the voyage, and to reduce, as far as possible, the risk of excessive accelerations.

6.6.1.4 Wheeled and tracked vehicles shall be placed so, that their axis of symmetry parallel to the longitudinal axis of the ship.

6.6.1.5 Vehicles with a flexible suspension shall be so secured that their chassis – as far as possible – were rigidly fixed, and movements due to the suspension of the vehicle, were not possible.

6.6.1.6 To avoid longitudinal shifting of the vehicles on the deck during adverse weather conditions, their wheels and/or tracks shall be fixed by the wedges or other equivalent means.

6.6.1.7 During the sea voyage vehicles with diesel engines shall not be left with their transmission gears on.

6.7 Calculations of cargo units' securing

6.7.1 Determination of external forces

6.7.1.1 External forces acting on the cargo unit in longitudinal, transverse and vertical direction shall be determined from the formula:

$$F_{(x, y, z)} = m \cdot a_{(x, y, z)} + F_{s(x,y)} \quad (6.7.1.1)$$

where:

$F_{(x, y, z)}$ – longitudinal, transverse and vertical forces, [kN];

m – the mass of the cargo unit, [t];

$a_{(x, y, z)}$ – longitudinal, transverse and vertical accelerations (see Table 6.7.1.2-1), [m/s²];

$F_{s(x,y)}$ – longitudinal and transverse force from the sea wave impacts (applies to cargoes carried on the open deck), [kN].

6.7.1.2 Accelerations referred to in 6.7.1.1 shall be determined according to Table 6.7.1.2-1.

Table 6.7.1.2-1
Values of basic longitudinal, transverse and vertical accelerations

	Transverse acceleration a_y , [m/s ²]	Longitudinal acceleration a_x , [m/s ²]
on the deck, high	7,1 6,9 6,8 6,7 6,7 6,8 6,9 7,1 7,4	3,8
on the deck, low	6,5 6,3 6,1 6,1 6,1 6,1 6,3 6,5 6,7	2,9
tweendeck	5,9 5,6 5,5 5,4 5,4 5,5 5,6 5,9 6,2	2,0
ship's bottom	5,5 5,3 5,1 5,0 5,0 5,1 5,3 5,5 5,9	1,5
distance from the aft perpendicular	0 0,1 0,2 0,3 0,4 0,5 0,6 0,7 0,8 0,9 L	
Vertical acceleration a_z , [m/s ²]		
7,6 6,2 5,0 4,3 4,3 5,0 6,2 7,6 9,2		

Basic accelerations data are valid for the following conditions:

- .1 operation in unrestricted area;
- .2 operation over the whole year;
- .3 voyage duration 25 days;
- .4 length of the ship 100 m;
- .5 speed of the ship 15 knots;
- .6 $B/GM \geq 13$ (B – breadth of the ship, GM –metacentric height).

Reduction of accelerations values, taking into account a season and the voyage duration, may be considered for restricted service area.

For ships of length less than 100 m and the speed other than 15 knots values of accelerations shall be corrected by application of the multiplier given in Table 6.7.1.2-2.

Table 6.7.1.2-2
The ship's length and speed correction coefficients

Length [m] Speed (knots)	50	60	70	80	90	120	120	140	160	180	200
9	1,20	1,09	1,00	0,92	0,85	0,79	0,70	0,63	0,57	0,53	0,49
12	1,34	1,22	1,12	1,03	0,96	0,90	0,79	0,72	0,65	0,609	0,56
15	1,49	1,36	1,24	1,15	1,07	1,00	0,89	0,80	0,73	0,68	0,63
18	1,64	1,49	1,37	1,27	1,18	1,10	0,98	0,89	0,82	0,76	0,71
21	1,78	1,62	1,49	1,38	1,29	1,21	1,08	0,98	0,90	0,83	0,78
24	1,93	1,76	1,62	1,50	1,40	1,31	1,17	1,07	0,98	0,91	0,85

In addition, in the case of ships which B/GM is less than 13, accelerations values shall be corrected by application the multiplier given in Table 6.7.1.2-3.

Table 6.7.1.2-3
 $B/GM < 13$ correction coefficients

B/GM	7	8	9	10	11	12	13 or more
on the deck, high	1,56	1,40	1,27	1,19	1,11	1,05	1,00
on the deck, low	1,42	1,30	1,21	1,14	1,09	1,04	1,00
tweendeck	1,26	1,19	1,14	1,09	1,06	1,03	1,00
cargo hold bottom	1,15	1,12	1,09	1,06	1,04	1,02	1,00

6.7.1.3 The forces caused by the wind and sea waves operation on cargo units shall be calculated according to following assumptions:

- the wind pressure = 1 kN/m²,
- pressure from the sea waves impact = 1 kN/m².

The force from waves impact shall be taken into account only for the deck cargoes of height about 2 m above the open deck.

6.7.2 Balancing of the forces and moments

The forces and moments analysis shall be performed for the following cargo shift:

- transverse cargo shift (towards right or left side);
- cargo overturn (towards right or left side);
- longitudinal cargo shift (in direction bow – stern).

In the case of symmetric securing system calculations for one side of the cargo unit are considered sufficient.

6.7.2.1 Transverse cargo shift

To prevent transverse shift of the cargo the following condition shall be satisfied:

$$F_y \leq \mu mg + CS_1 f_1 + CS_2 f_2 + \dots + CS_n f_n \quad (6.7.2.1)$$

where:

n – number of applied lashings;

F_y – transverse force acting on the cargo (see Fig. 6.7.2.1 and p. 6.7.1.1), [kN];

μ – coefficient of friction;

($\mu = 0,3$ for a set steel-wood or steel-rubber),

($\mu = 0,1$ for a set steel-steel, dry),

($\mu = 0,0$ for a set steel-steel, wet);

m – cargo unit mass, [t];

g – acceleration of gravity = $9,81 \text{ m/s}^2$;

CS – calculation strength of the securing devices arranged in a transverse direction = $\frac{MOZ}{1,5}$, [kN];

f – function μ and lashings' inclination angle α (see Fig. 6.7.2.1 and Table 6.7.2.1)

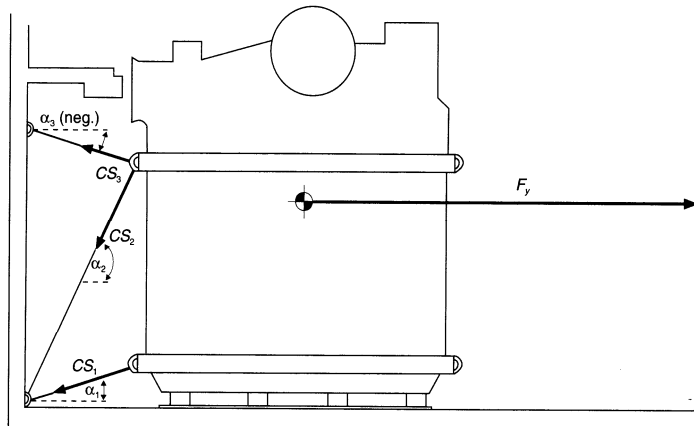

Fig. 6.7.2.1 Balance of transverse forces

Table 6.7.2.1 Values f

$\alpha \backslash \mu$	0,3	0,1	0,0	-30°	-20°	-10°	0°	10°	20°	30°	40°	50°	60°	70°	80°	90°
0,3	0,72	0,84	0,93	1,00	1,04	1,04	1,02	0,96	0,87	0,76	0,62	0,47	0,30			
0,1	0,82	0,91	0,97	1,00	1,00	0,97	0,92	0,83	0,72	0,59	0,44	0,27	0,10			
0,0	0,87	0,94	0,98	1,00	0,98	0,94	0,87	0,77	0,64	0,50	0,34	0,17	0,00			

Angles α in principle shall not exceed 30°, otherwise it shall be considered to omit lashings in the formula (6.7.2.1)

6.7.2.2 Transverse overturn of the cargo

To prevent transverse overturn of the cargo the following condition shall be satisfied:

$$F_y a \leq bmg + CS_1 C_1 + CS_2 C_2 + \dots + CS_n C_n \quad (6.7.2.2)$$

where:

F_y, m, g, CS, n – as specified in 6.7.2.1

a – arm of a overturning force, [m] (see Fig. 6.7.2.2);

b – arm of a force maintaining stability of the system, [m] (see Fig. 6.7.2.2);

c – arm of a force in a securing device, [m] (see Fig. 6.7.2.2).

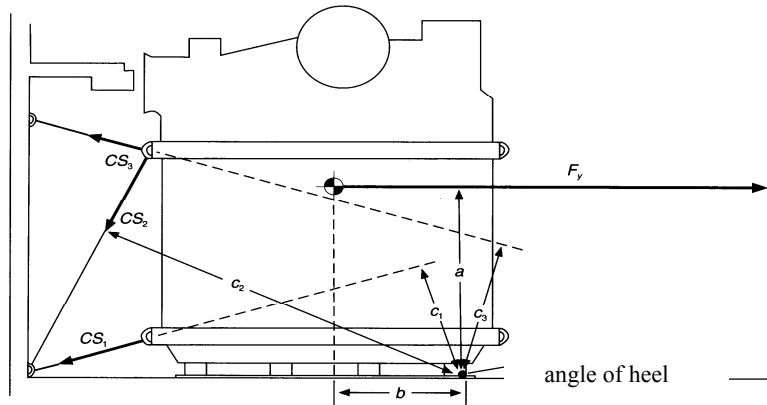

Fig. 6.7.2.2 Balance of moments in transverse direction

6.7.2.3 Longitudinal cargo shift

To prevent longitudinal shift of the cargo the following condition shall be satisfied:

$$F_x \leq \mu(mg - F_z) + CS_1 f_1 + CS_2 f_2 + \dots + CS_n f_n \quad (6.7.2.3)$$

where:

F_x – longitudinal force acting on the cargo, [kN];

μ, g, n – as specified in 6.7.2.1,

F_z – vertical force acting on the cargo,

CS – calculation strength of the securing devices arranged in a longitudinal direction = $\frac{MOZ}{1,5}$, [kN].

7 REQUIREMENTS RELATING TO SOLAS CONVENTION, CHAPTER VII – CARRIAGE OF DANGEROUS GOODS

7.1 General

7.1.1 Application

7.1.1.1 The requirements of chapter 7 to supply and logistic support ships in the case of carriage dangerous goods not being a ship's stores.

7.1.2 Definitions

- .1** Dangerous goods – goods classified in accordance with IMDG Code.
- .2** IMDG Code – *International Maritime Dangerous Goods (IMDG) Code* adopted by IMO by resolution A.716(17), as amended.
- **.3** FSS Code – *Fire Safety System Code* adopted by IMO by MSC.98(73) on 5 December 2000, as amended.
- .4** Package – a product ensuring maintenance of a specified quality packaged goods, to adapt them to the transport, storage and presentation, as well as protecting the environment from the harmful effects of certain products.

7.2 Carriage requirements

7.2.1 The carriage of dangerous goods by naval ships shall be in compliance with the provisions of the present sub-chapter.

7.2.2 The requirements of sub-chapter 7.2 do not apply to dangerous goods carried in ships' stores or being a ship's equipment.

7.2.3 Dangerous goods carried in packages shall be so stowed and secured that the risk to the crew and ship is reduced to minimum.

7.2.4 The packages shall satisfy, applicable to the specific goods, provisions of IMDG Code.

7.2.5 Marking of packaged dangerous goods shall satisfy, applicable to the specific goods, provisions of IMDG Code..

7.2.6 Wherever naming of dangerous goods is required, the correct technical name of the goods shall be used and the correct description given in accordance with the classification set out in IMDG Code, and the trade names alone shall not be used.

7.3 Documents

7.3.1 The shipping documents prepared by the shipper shall include, or be accompanied by, a signed certificate or declaration that the shipment offered for carriage is properly packaged and marked, labelled or placarded, as appropriate, and in proper condition for carriage.

7.3.2 The persons responsible for the packing of dangerous goods in a freight container or road vehicle shall provide a signed container packing certificate or vehicle packing declaration stating that the cargo in the unit has been properly packed and secured and that all applicable transport requirements have been met. Such a certificate or declaration may be combined with the documents referred to in 7.3.1.

7.3.3 Where there is due cause to suspect that a freight container or road vehicle in which dangerous goods are packed is not in compliance with the requirements of 7.3.1 or 7.3.2, or where a container packing certificate or vehicle packing declaration is not available, the freight container or vehicle shall not be accepted for shipment.

7.3.4 Each ship carrying dangerous goods shall have a special list or manifest setting forth, in accordance with the classification set out in IMDG Code, the dangerous goods on board and the location thereof. A detailed stowage plan, which identifies by class and sets out the location of all dangerous goods on board, may be used in place of such a list or manifest. A copy of one of these documents shall be made available before departure to the person or organization designated by the port State Authority.

7.3.5 Cargo transport units, including freight containers, shall be loaded, stowed and secured in accordance with the approved by PRS *Cargo Securing Manual*.

7.3.6 The *Cargo Securing Manual* shall contain the requirements at least equivalent to the guidelines developed by IMO¹⁾.

7.4 Carriage of dangerous goods

The present sub-chapter 7.4 contains requirements complying with the provisions of Regulation 19 of Chapter II-2 *SOLAS Convention*.

7.4.1 General requirements

7.4.1.1 The present sub-chapter provides relating to the carriage of dangerous goods, addressed to fire safety additional requirements in relation to the requirements, included in *Part V – Fire protection*, applicable to all supply and logistic support ships.

7.4.1.2 Specific range of the additional requirements applicable to ships carrying dangerous goods shall be determined depending on the ship type and kind of the cargo space. Following categories are distinguished:

- .1** ships and cargo spaces not specifically designed for the carriage of freight containers, but intended for the carriage of dangerous goods in packaged form, including goods in freight containers and portable tanks;

¹⁾ See IMO Circulars: MSC/Circ. 385 and MSC/Circ. 745.

- .2 containerships and cargo spaces intended for the carriage of dangerous goods in freight containers and portable tanks;
- .3 ro-ro ships and ro-ro spaces intended for the carriage of dangerous goods.

7.4.2 Specific requirements

Range of application of the requirements of sub-chapter 7.4.2 for different dangerous goods is specified in Table 7.4.2.

7.4.2.1 Water supply

7.4.2.1.1 Arrangements shall be made to ensure immediate availability of a supply of water from the fire main at the required pressure by:

- .1 permanent pressurization of the installation, or
- .2 suitably placed remote arrangements for the fire pumps operation.

7.4.2.1.2 The quantity of delivered water shall be capable of supplying four nozzles of a size and at pressures as specified in sub-chapter 3.2 of *Part V – Fire protection*, capable of being trained on any part of the cargo space when empty.

7.4.2.1.3 Means shall be provided for effective cooling the designated under-deck cargo space by at least 5 l/min per square meter of the horizontal area of a cargo space by means of:

- .1 fixed arrangements of spraying nozzles, or
- .2 flooding the cargo space with water.

For this purpose in small cargo spaces and in small areas of larger cargo spaces hoses may be used.

Uwagi:

- 1) When mechanically-ventilated spaces are required by the *IMDG Code*.
- 2) In all cases stow horizontally 3 m away from the machinery spaces boundaries.
- 3) See *IMDG Code*, as amended
- 4) As appropriate to the goods to be carried.
- 5) Refers to flashpoint.
- 6) Stowage of class 5.2 dangerous goods under deck or in enclosed ro-ro spaces is prohibited.

7.4.2.1.4 The drainage and pumping arrangements shall be such as to prevent the building-up of free surfaces. The drainage system shall be capable of removing no less than 125% of the combined capacity of the water spraying system pumps and the required number of fire hose nozzles.

The drainage system valves shall be operable from outside the protected space at a position in the vicinity of the extinguishing system controls.

Bilge wells shall be of sufficient holding capacity and shall be arranged at the side shell of the ship at a distance from each other ensuring effective drainage of these spaces, but of not more than 40 m.

7.4.2.1.5 If the compliance with the provisions of 7.4.2.1.4 is not possible, the adverse effect upon stability of the added weight and free surface shall be taken into account¹⁾.

7.4.2.1.6 Zamiast spełnienia wymagań punktu 7.4.2.1.3 dopuszcza się zalewanie wyznaczonego pomieszczenia pod pokładem odpowiednim określonym czynnikiem.

7.4.2.1.7 The total required capacity of the water supply shall satisfy paragraphs 7.4.2.1.2 i 7.4.2.1.3, if applicable, simultaneously calculated for the largest designated cargo space. The capacity requirements of paragraph 7.4.2.1.2 shall be met by the total capacity of the main fire pumps, not including the capacity of the emergency fire pump, if fitted.

If a drencher system is used to satisfy paragraph 7.4.2.1.3, the drencher pump shall also be taken into account in this total capacity calculations.

7.4.2.2 Sources of ignition

7.4.2.2.1 Electrical equipment and wiring shall not be fitted in enclosed cargo spaces or vehicle spaces unless it is essential for operational purposes.

7.4.2.2.2 However, if electrical equipment is fitted in such spaces, it shall be of certified type for use in dangerous environments to which it may be exposed unless it is possible to completely isolate the electrical system (e.g. by removal of links in the system other than fuses).

7.4.2.2.3 Cable penetrations of the decks and bulkheads shall be sealed against the passage of gas or vapour.

¹⁾ See IMO: ResolutionA.123(V).

7.4.2.2.4 Through run of cables and cables within the cargo spaces shall be protected against damage from impact.

7.4.2.2.5 Any other equipment which may constitute a source of ignition of flammable vapour shall not be permitted.

7.4.2.3 Detection system

7.4.2.3.1 Ro-ro spaces shall be fitted with a fixed detection and fire alarm system complying with the requirements of the *FSS Code*.

7.4.2.3.2 All other types of cargo spaces shall be fitted with either a fixed fire detection and fire alarm system or a sample extraction smoke detection system complying with the requirements of the *FSS Code*.

7.4.2.3.3 If a sample extraction smoke detection system is fitted, particular attention shall be given to paragraph 2.1.3 in chapter 10 of the *FSS Code* in order to prevent the leakage of toxic fumes into occupied areas.

7.4.2.4 Ventilation

7.4.2.4.1 In enclosed cargo spaces adequate power ventilation shall be provided. The arrangements shall be such as to provide for at least 6 air changes per hour in the cargo space, based on an empty cargo space, and for removal of vapours from the upper or lower parts of the cargo space, as appropriate.

7.4.2.4.2 The fans shall be such as to avoid the possibility of ignition of flammable gas/air mixtures.

7.4.2.4.3 Over inlet and outlet ventilation openings suitable net mesh guards with diameter of maximum 13x13 mm, shall be fitted.

7.4.2.5 Bilge pumping

7.4.2.5.1 Where it is intended to carry flammable or toxic liquids in enclosed cargo spaces, the bilge pumping system shall be designed to protect against inadvertent pumping of such liquids through machinery space piping or pumps. Where large quantities of such liquids are carried, consideration shall be given to the provision of additional draining those cargo spaces.

7.4.2.5.2 If the bilge drainage system is additional to the system served by pumps in the machinery space, the capacity of the system shall be not less than 10 m³/h per cargo space served.

If the additional system is common, the capacity need not exceed 25 m³/h.

The additional bilge system need not be arranged with redundancy.

7.4.2.5.3 Whenever flammable or toxic liquids are carried, the bilge line into the machinery space shall be isolated either by fitting a blank flange or by a closed lockable valve.

7.4.2.5.4 Enclosed spaces outside machinery space containing bilge pumps serving cargo spaces intended for carriage of flammable or toxic liquids shall be fitted with separate mechanical ventilation giving at least 6 air changes per hour.

If the space has access from another enclosed space, the door shall be self-closing.

7.4.2.5.5 If bilge drainage of cargo spaces is arranged by gravity drainage, the drainage shall be either led directly overboard or to a closed drain tank located outside the machinery space. The tank shall be provided with a vent pipe to a safe location on the open deck.

Drainage from a cargo space into bilge wells in a lower space is only permitted if that space satisfies the same requirements as the cargo space above.

7.4.2.6 Personnel protection

7.4.2.6.1 In addition to the fire-fighter's outfits required by paragraph 7.4.1 of *Part V – Fire protection*, four sets of full protective clothing, resistant to chemical attack, shall be provided. The protective clothing shall cover all skin, so that no part of the body is unprotected.

7.4.2.6.2 At least two self-contained breathing apparatuses additional to those required by paragraph 7.4.2 of *Part V – Fire protection*, shall be provided. Two spare charges suitable for use with the breathing apparatus shall be provided for each required apparatus.

The ship which is equipped with suitably located means for fully recharging the air cylinders free from contamination need carry only one spare charge for each required apparatus.

7.4.2.7 Additional fire-fighting equipment

For the cargo spaces portable extinguishers with a total capacity of at least 12 kg of dry powder or equivalent shall be provided. These extinguisher shall be in addition to the required by the sub-chapter 7.2 of *Part V – Fire protection*.

7.4.2.8 Insulation of machinery space boundaries

7.4.2.8.1 Bulkheads forming boundaries between cargo spaces and machinery spaces of category A shall be insulated to A-60 class standard.

If such insulation is not provided, the dangerous goods shall be stowed at least 3 m horizontally away from such bulkheads.

7.4.2.8.2 Other boundaries between such spaces shall also be insulated to A-60 class standard.

7.4.2.9 Water-spraying system

7.4.2.9.1 Each open ro-ro space having a deck above it and each space deemed to be closed ro-ro space not capable of being sealed shall be fitted with an approved fixed pressure water-spraying system for manual operation which shall protect all part of any deck and vehicle platform in the space. Application of any other fixed fire-extinguishing system shall be subject of separate PRS consideration. Full-scale test shall show the system to be no less effective.

7.4.2.9.2 In each case the drainage system shall be capable to remove no less than 125% of the combined capacity of both the water-spraying system pumps and the required number of fire hose nozzles.

7.4.2.9.3 The drainage system valves shall be operable from outside the protected space at a position in the vicinity of the extinguishing system controls.

7.4.2.9.4 Bilge wells shall be of sufficient holding capacity and shall be arranged at the side shell of the ship at a distance from each other ensuring effective drainage of these spaces.

7.4.2.9.5 If the compliance with the provisions of 7.4.2.9.2 to 7.4.2.9.4 is not possible, the adverse effect upon stability of the added weight and free surface shall be taken into account¹⁾.

7.4.2.10 Separation of ro-ro spaces

7.4.2.10.1 In ships having ro-ro spaces, a separation shall be provided between a closed ro-ro space and an adjacent open ro-ro space. The separation shall be such as to minimize the passage of dangerous vapours and liquids between such spaces.

Such separation need not be provided if the ro-ro space is considered to be a closed cargo space over its entire length and fully complies with the relevant special requirements of the present sub-chapter.

7.4.2.10.2 In ships having ro-ro spaces, a separation shall be provided a closed ro-ro space and the adjacent open deck. The separation shall be such as to minimize the passage of dangerous vapours and liquids between such spaces.

A separation need not be provided if the arrangement of the closed ro-ro spaces are in accordance with those required for the dangerous goods carried on adjacent open decks.

7.4.3 Dokument zgodności

Each ship intended for the carriage of dangerous goods shall be provided with an appropriate document confirming compliance of construction and equipment with the requirements of the present sub-chapter. A sample of such document is contained in IMO circular MSC/Circ.1027 of 6 June 2002.

¹⁾ See: IMO Resolution A.123(V).

8 REQUIREMENTS RELATED TO INTERNATIONAL REGULATIONS FOR PREVENTING COLLISIONS AT SEA (COLREG CONVENTION)

8.1 General

8.1.1 Application

8.1.1.1 Requirements of the Chapter 8 apply to:

- .1** combat ships, as well as support naval vessels – in relation to the scope of the required signalling appliances;
- .2** signalling means designated for installation on ships defined in 1 – in relation to their construction and arrangement on the ship.

8.1.1.2 To supply ships applies minimum set of signalling means listed in Annex to the present chapter.

8.1.2 Definitions and descriptions

For the purpose of the Chapter 8 following definitions have been assumed:

Length and breadth of a vessel – a vessel's overall length and the greatest breadth.

Ships' whistle – any sound signalling appliance capable of producing short and prolonged blasts prescribed in the requirements of Chapter 8.

Lamp – a portable appliance showing white or colour light.

Light – an appliance showing white or colour light, with their prescribed exhibition on the vessel.

Towing light – a yellow light indicating the vessel's towing operations. Not exhibited during alongside towing.

All-round light – a light showing an unbroken light over an arc of the horizon of 360° at the horizontal plane of the maximum luminous intensity.

Sector horizontal light – an appliance showing light in the assigned sector, at the horizontal plane of the maximum luminous intensity.

Sound level A – level of acoustic pressure measured by use of corrective characteristic A, (the characteristic defined in *IEC Publication 123/1961 – Recommendation for sound level meters*).

Vessel restricted in her ability to manoeuvre – a vessel which from the nature of her work is restricted in her ability to manoeuvre and is therefore unable to keep out of the way of another vessel.

The term „vessel restricted in her ability to manoeuvre” shall include:

- .1** a vessel engaged in laying, servicing or picking up a navigation mark, submarine cable or pipeline;
- .2** a vessel engaged in dredging, surveying or underwater operations;

- .3 a vessel engaged in replenishment or transferring persons, provisions or cargo while underway;
- .4 a vessel engaged in the launching or recovery of aircrafts;
- .5 a vessel engaged in a towing operation such as severely restricts the towing vessel and her tow in their ability to deviate from their course.

Vessel constrained by her draught – a power-driven vessel which, because of her draught in relation to the available depth and width of navigable water, is severely restricted in her ability to deviate from the course she is following.

Signal – state or physical process being the carrier of information (sound or light, smoke generation, display of signs of desired colours and shapes, etc.).

Prolonged blast – sound blast of 4 to 6 seconds duration.

Short blast – sound blast of about 1 seconds duration.

Flashing light – a light flashing at regular intervals at a frequency of 120 flashes or more per minute.

Hoisted device – a device hoisted to the set position of use.

Portable device – a device carried to the set position of use.

Fixed device – a device permanently fixed at the set position of use.

Height above the hull – height above the uppermost continuous deck measured from the position of the device location.

8.1.3 Range of survey

8.1.3.1 Subject to PRS survey during manufacture are:

- .1 navigation lights;
- .2 signalling lamps;
- .3 sound signal means;
- .4 pyrotechnic signal means;
- .5 radar reflectors;
- .6 signal shapes.

8.1.3.2 Equipment of ships with signalling means, as well as their installation on ships shall be carried out under PRS supervision.

8.1.3.3 Prior to the commencement of a ship's construction the following technical documentation of signal means shall be submitted to PRS for consideration and approval:

- .1 list of signal means with their basic characteristics;
- .2 plans for positioning of the navigation lights and sound signalling equipment and co-ordinate axes of their arrangement, as well as plan for positioning of signal lights and pyrotechnic distress signals;

- .3 plan for positioning of sidelights in cavities and the dimensions of cavities, as well as for positioning of the other lights and horizontal and vertical sectors of light;
- .4 plan of shadow sectors of all-round lights with a horizon arc of visibility 360°, except anchor lights;
- .5 range of visibility of masthead lights (forward and after one) at a distance of 1000 metres from the stern when viewed from the sea level.

8.1.3.4 Upon approval by PRS of technical documentation, the following execution documentation shall be submitted for consideration:

- .1 signalling means attachment drawings;
- .2 test program (dock and sea-trials).

8.1.3.5 Range of technical documentation for alteration and/or reconstruction of the ship shall be in each case agreed with PRS.

8.1.4 Marking of pyrotechnic means

Marking of pyrotechnic signalling means shall be indelible, and shall contain the expiry date, the purpose and brief instructions for use. The label shall be affixed to each piece of pyrotechnic mean (except rocket flares launched from the signal pistol), and on its packaging.

8.2 Equipment of ships with signalling means

8.2.1 General

8.2.1.1 Set of signalling means presented in the present chapter corresponds with the requirements of the *International Convention for the Safety of Life at Sea, 1974* (further referred to as *SOLAS 1974*), as amended, and the *International Regulations for Preventing Collisions at Sea, 1972* (further referred to as *COLREG 1972*), as amended.

Table 8.2.1
Essential set of signal means for combat and support ships

No.	Ship type	Navigation lights [number]						Signalling lamps [number]		Sound signal means [number]			Signal shapes [number]		
		masthead	sidelight starboard	sidelight portside	sternlight	anchor	awaryjna	manoeuvring ¹⁾	daylight	gwizdek	bell	gong	ball	cone	diamond (doubled cone)
1	2	3	4	5	6	7	8	9	10	11	12	13	14	15	16
1	Combat and support ships	2/1 ¹⁾	1	1	1	2/1 ¹⁾	2	1	One for ship of displacement greater than 150 t.	1	1 ²⁾	One for ship of length greater than 100 m	3	One for power-driven manned ship ³⁾	1
2	Non-propelled objects designated for being towed ⁴⁾ or pushed	–	1	1	1 ³⁾	2/1 ¹⁾	2	–		1	1 ²⁾		3		1 ⁵⁾

¹⁾ 2 – for ships of length 50 m and over, 1 – for ships of length less than 50 m. Ships of length less than 50 m may be provided with two lights.

²⁾ See 8.2.2.6.

³⁾ For ships designated for being towed – not required.

- 4) Towed ships and objects inconspicuous, partly submerged, or their groups shall be equipped with:
2 white navigation lights, all-round horizontal, if the object's breadth is less than 25 m,
4 lights as above. – if the object's breadth is 25 m and over,
5 lights – if the length of the ship or object is 100 m and over,
1 additional diamond if the towing set's length exceeds 200 m.
- 5) For ships designated for being pushed – not required.

8.2.1.2 The signal means set, covered by the requirements of present chapter, consists of:

- .1 navigation lights;
- .2 signalling lamps;
- .3 acoustic signal means;
- .4 signal shapes;
- .5 pyrotechnic signal means;
- .6 radar reflectors.

8.2.2 Outfit of combat and support ships

8.2.2.1 Essential set of signal means required for ships determines Table 8.2.1, while provision with the pyrotechnic signal means shall conform with Table 8.2.3.

8.2.2.2 On combat and support ships electric navigation lights shall be applied. Providing the ship with the spare lights in accordance with 8.2.2.4 is recommended. Supply of the electric lights shall conform with the requirements of *Part VIII – Electrical installations and control systems*.

8.2.2.3 In the case of application in the ship double electric lights (e.g. lights with two independent sources of light, one of which is supplied from the ship's main source of electric energy, and the other from the emergency source of electric energy) it is recommended that ship is additionally provided with the spare set of lights.

8.2.2.4 The spare set of lights shall include:

- .1 masthead lights, sidelights, emergency lights and anchoring lights;
- .2 lights indicating specific operations (towing, being towed, pilot or restricted ability to manoeuvre).

8.2.2.5 Each ship shall be provided with the following spare parts to lights and lamps:

- .1 one filter to each light (emergency, side, restricted ability to manoeuvre, towing) if for the lights colour lenses are not applied;
- .2 two bulbs for each electric light and lamp of the essential set.

8.2.2.6 The bell and gong may be substituted by other devices with, respectively, the same sound characteristic – provided that manual signals' transmission shall always be possible.

8.2.2.7 Ships constrained by their draught, supplementary to the lights required in Table 8.2.1 for power-driven ships, may be provided with three red lights with characteristic defined in No. 9 of Table 8.3.1, as well as with one cylinder.

If the ship is provided with such lights they can be included to the emergency lights set required in Table 8.3.1.

8.2.3 Ships' outfitting with pyrotechnic signal means

Ships' outfitting with pyrotechnic signal means shall comply with the requirements of Table 8.2.3.

Table 8.2.3
Ships' outfitting with pyrotechnic signal means

Rocket parachute flares (marine) red	Sound rocket or petards	Red hand flares ¹⁾	White hand flares ^{1), 2)}	Green rocket flares	Red rocket flares	Orange buoyant smoke signals
12	12 ³⁾	12 ³⁾	12 ³⁾	12 ³⁾	12 ³⁾	12 ³⁾

¹⁾ The ships designated for carriage of oil products shall not be provided with hand flares.

²⁾ Not required for ships equipped with the daylight signalling lamp.

³⁾ Recommended numbers.

8.3 Technical requirements

8.3.1 Navigation lights

8.3.1.1 Lights categories

The present chapter sets out the requirements for three basic categories of navigation lights:

- .1 lights category I – designated for ships of length 50 m and over;
- .2 lights category II – designated for ships of length 12 m and over, but less than 50 m;
- .3 lights category III – designated for ships of length less than 12 m.

8.3.1.2 Required lights characteristics

The essential functional characteristics of individual lights shall correspond to characteristics presented in Table 8.2.1.

8.3.2 General technical requirements

8.3.2.1 For navigation lights described in Table 8.3.1 electrical source of energy – in accordance with 8.3.6.1 – shall be applied.

8.3.2.2 The lights shall be of design protecting from water penetration over current conducting parts.

Table 8.3.1
Essential parameters of navigation lights

No.	Name of light	Light's colour	Minimum range of visibility (luminous range) of light in nautical miles			Lights' angle of visibility at the horizontal plane	
			lights of category I	lights of category II	lights of category III	total angle	angle's' distribution
1	2	3	4	5	6	7	8
1	Masthead Towing	white	6	5 ¹⁾	2	225°	112,5° on either side from the plane of symmetry, counted from the ship's bow
2	Side Stb.	green	3	2	1	112,5°	112,5° on starboard side from the plane of symmetry, counted from the ship's bow
3	Side PS	red	3	2	1	112,5°	112,5° on port side from the plane of symmetry, counted from the ship's bow
4	Combined bi-colour	green red	–	2	1	225°	Po 112,5° on either side of the plane of symmetry, counted from the ship's bow: starboard side – green sector, port side – red sector
5	Combined tri-colour	green red white	–	2 ⁵⁾	1 ²⁾	360°	Green – sector 112,5° on starboard side from the parallel to the plane of symmetry, counted from the ship's bow; Red – sector 112,5° on portside from the parallel to the plane of symmetry, counted from the ship's bow; zacząć od dziobu okrętu; White – sector 135°, 67,5° on either side from the plane of symmetry, counted from the ship's stern

1	2	3	4	5	6	7	8
6	Sternlight	white	3	2	2	135°	67,5° on either side from the plane of symmetry, counted from the ship's stern
7	Towing	yellow	3	2	2	135°	67,5° on either side from the plane of symmetry, counted from the ship's stern
8	1. Anchor 2. Pilot 3. Restricted manoeuvre ability	white	3	2	2	360°	all-round, 360°
9	1. Pilot 2. Emergency 3. Restricted in ability to manoeuvre 4. Constrained by draught	red	3	2	2	360°	all-round, 360°
10	Air cushion crafts ³⁾	yellow	3	2	2	360°	all-round, 360°
11	Ships and objects being towed, inconspicuous partly submerged	white	3	3	3	360°	all-round, 360°

¹⁾ On ships of length less than 20 m minimum range of visibility – 3 Nm.

²⁾ Minimum range of visibility of white light sector – 2 Nm.

³⁾ Flashing light.

⁴⁾ Range of visibility shall not be less than 1Nm, however not greater than range of visibility of other installed on ship lights emitting light over an arc of 360°.

8.3.3 Lights housing

8.3.3.1 Light housing and its components shall be made of materials resistant to sea water, or shall be preserved by appropriate anti-corrosion coating, and shall be of hose-proof construction (IP56).

8.3.3.2 The design of the light shall preclude the possibility of such warm-up of the light, which could cause damage of the optical parts or deformation of the housing under temperature changes encountered during the operation in all climatic conditions.

8.3.3.3 The light housing design shall provide for prompt change of bulbs.

8.3.3.4 Each light shall be so constructed that the discharge of condensing water vapour and inflow of the fresh air, adequately to the required degree of protection, is ensured.

8.3.3.5 The design of main and spare lights housing shall provide for their reliable mounting in the operation position, and – in the case of necessity – for prompt dismounting and re-mounting. The lights of horizontal light emission at angle 360° , mounted one above the other, shall be provided with clamps for their hoisting.

8.3.4 Lenses

→ **8.3.4.1** For navigation lights lenses or plain glass may be applied, and their functional characteristics shall conform with the requirements described in columns 4, 5 of 6 of Table 8.3.1.

8.3.4.2 Internal and external surfaces of lenses and plain glasses shall be sufficiently smooth, and glass free of dirt, air bulbs and defects affecting the deterioration of the light characteristics.

8.3.4.3 The lenses for electric lights shall be such, that directional characteristic in the vertical plane ensures at least maintenance:

- Required in 8.3.6.1 luminous intensity in a range of visibility arc up to 5° on either side from the lens' horizontal plane of symmetry;
- 60% required luminous intensity in a range of emission arc up to $7,5^\circ$ on either side from the lens' horizontal plane of symmetry.

8.3.4.4 Direction characteristic in the horizontal plane of sidelights shall be such, that the lights fitted on board shall show required in 8.3.6.1 luminous intensity in the forward direction, and shall decrease to reach practical cut-off between 1° and 3° outside the prescribed sectors.

For sternlight and masthead lights at $22,5^\circ$ abaft the beam for sidelights, the minimum required intensities shall be maintained over the arc of the horizon up to 5° within the limits of the sectors prescribed in Table 8.3.1. From 5° within

the prescribed sectors the intensity may decrease by 50% up to the prescribed limits, it shall decrease steadily to reach practical cut-off at not more than 5° outside the prescribed sectors.

8.3.5 Colour light filters

8.3.5.1 Colour light in the navigation lights may be obtained by applying appropriate filters, as well as lenses.

Coloured plain glasses may be used provided that corresponding chromatic characteristics are ensured throughout the filter surface. The use of tinted lenses is, in each case, subject to special consideration by PRS.

8.3.5.2 Colour light filters used in navigation lights may be made of tinted glass or of surface coloured glass (covered). Light filters may be made of plastics provided that in each case their characteristics are at least the same as that of filters made of glass.

8.3.5.3 The chromaticity of light emitted by the ship's lights shall correspond with the standard diagram for each colour specified by the International Commission on Illumination (CIE). For the specific colours, the boundaries of area in the diagram are given by indicating the corner co-ordinates defined in Table 8.3.5.3. Colour of light of the navigation lights shall be assumed as the resultant of applied in the optical system filter and source of light. Transmittance coefficients of the colour filters shall of such value, that the requirements specified in Table 8.3.1 and 8.3.5.3 are satisfied.

Table 8.3.5.3
Corner co-ordinates x , y of the boundaries

Colour	Co-ordinate	Intersection points					
Red	x	0,680	0,660	0,735	0,721	–	–
	y	0,320	0,320	0,265	0,259	–	–
Green	x	0,028	0,009	0,300	0,203	–	–
	y	0,385	0,723	0,511	0,356	–	–
White	x	0,525	0,525	0,452	0,310	0,310	0,443
	y	0,382	0,440	0,440	0,348	0,283	0,382
Yellow	x	0,612	0,618	0,575	0,575		
	y	0,382	0,382	0,425	0,406		

8.3.5.4 The coloured filter arc height and length shall be such that the filter covers all the internal surface of the lens.

8.3.5.5 Internal and external surfaces of the filters shall be, as far as possible, free of defects and indentations, and filter's glass free of air bulbs, foreign matters and colour streaks.

8.3.5.6 Filters shall be so fixed inside the lights that there is no possibility of their self-shift during utilization of the lamps in the ship.

8.3.5.7 Filters' clamps in the sidelights and combined bi-colour and tri colour lights shall be so arranged, that possibility of insertion of red filter in a place of green one, and vice versa, is excluded.

8.3.6 Light source

8.3.6.1 The light source in electric lights shall be an electric bulb. Minimum luminous intensity of lights required in Table 8.2.1 in a range of visibility shall not be less than calculated from the formula:

$$I = 3,43 \times 10^6 \times T \times D^2 \times K^{-D}, [\text{cd}] \quad (8.3.6.1)$$

where:

I – required luminous intensity for the range of visibility D , [cd];

T – threshold factor, equal to 2×10^{-7} [lx];

D – range of visibility (luminous range) of the light, [nautical miles];

K = atmospheric transmissivity factor. To ensure standard ranges of the lights visibility $K = 0.8$ is assumed, which corresponds to a meteorological visibility of approximately 13 nautical miles.

The values of luminous intensity determined from the 3.6.1 are presented in Table 8.3.6.1.

Table 8.3.6.1
Lights' values of luminous intensity

Range of luminous intensity, [nautical miles]	1	2	3	4	5	6
Luminous intensity, [cd] for $K = 0,8$	0,9	4,3	12	27	52	94

Luminous intensity of the navigation lights shall not exceed 150 cd.

Luminous intensity of the non-electric light shall, as far as possible, correspond to luminous intensity determined from the above formula.

8.3.6.2 Light source in the light shall be set vertically so that the lens' horizontal plane of symmetry divides luminous part in two equivalent parts.

8.3.6.3 Position of the light source inside the light shall be arranged so, that it can be set in one particular position only, precluding from its self-change of position during utilization of the light in the ship, as well as an easy replacement of the light source in the light is possible.

8.3.6.4 The electric lights shall be provided with marine make sockets and bulbs of construction excluding their self-unscrewing.

8.3.6.5 For the electric lights – with the exception of double lights – neither more than one bulb, nor dual-filament (main and replacing) bulbs shall be applied.

8.3.7 Signalling lamps (acc. to SOLAS 74, chapter 11 and COLREG 72, Annex I, p. 12)

8.3.7.1 Required characteristics for signalling lamps are included in Table 8.3.7.1.

Table 8.3.7.1
Signalling lamps characteristics

No.	Name of lamp	Light colour	Range of light visibility, [nautical miles]		Angles of light emission in the horizontal plane	
			for group I ships	for group II ships	total angle	angle's distribution
1	Daylight signalling	white	3 ¹⁾	–	Direction action (the light is emitted in the required direction)	
2	Manoeuvring	white	5	–	360°	all-round

¹⁾ Range of visibility in the daytime and clear air.

8.3.7.2 The signalling lamps shall satisfy the general requirements of 8.1.3.

8.3.7.3 Luminous intensity of a single blast in the horizontal plane shall not be less than obtained from the formula:

$$I_b = \frac{0,2 + t_b}{t_b} I, \text{ [cd]}, \quad (8.3.7.3)$$

where:

I_b – blast luminous intensity, [cd];

t_b – blast duration, [s];

I – luminous intensity, in accordance with 8.3.6.1, [cd].

If the above formula is applied for daylight signalling lamps – the value I obtained from the formula 8.3.6.1 shall be multiplied by 5000.

8.3.7.4 Daylight signalling lamp shall be an electric lamp supplied from the general electrical web and, if not provided with accumulators battery, from the emergency source of power. The lamp shall be provided with housing of IP22 type.

The lamp shall be so constructed that is capable of being carried or operated by one person.

8.3.7.5 The manoeuvre lamp shall be an electric lamp and provide light signals when performing the manoeuvre of the ship. The duration of a blast shall be about 1 s, the interval between blasts – about 1 s, the interval between successive signals – not less than 10 s.

8.4 Sound signal appliances – (acc. to COLREG 72, Annex. III, p.1)

8.4.1 General

8.4.1.1 Sound signal appliances shall be so constructed as to be reliable in all weather conditions and provide the required level of volume, continuity and purity of the individual sound signals.

8.4.2 Whistles

8.4.2.1 Fundamental frequencies and range of audibility

Fundamental whistles properties shall satisfy the requirements presented in Table 8.3.2. The fundamental frequencies of the sound signal shall lie within the range 70–700 Hz (range of permissible fundamental frequencies). The range of the audibility of the signal from the whistle shall be determined by those frequencies, which may include the fundamental and one or more higher frequencies, which lie within the range 180–700 Hz ($\pm 1\%$) and which provide the sound pressure levels specified in Table 8.3.6.1.

8.4.2.2 Directional properties

The whistle construction shall provide for compliance with the requirements of sub-chapter 8.5.4.2.

8.4.2.3 Sound of whistle shall have only one dominant frequency and intensity fluctuation, hissing and other distortions shall not occur. The beginning and the end of each signal, whatever its duration, shall be clear and discrete. It is recommended that the whistle is provided with a device for self-management of whistle transmission (in fog), allowing to regulate the duration of the transmitted signals and manual transmission of signals, and in the latter cases the device shall automatically shut itself off.

Table 8.4.2.3
Requirements for whistles

Length of ship, [m]	Fundamental frequency of the whistle, [Hz]	1/3 octave band level ¹⁾ , at 1 m, referred to 2×10^{-5} N/m ² , [dB]	Range of audibility ²⁾ , [nautical miles]
$200 \leq L$	70–200	143	2,0
$75 \leq L < 200$	130–350	138	1,5
$20 \leq L < 75$	250–700	130	1,0
$L < 20$	250–700	120	0,5

- ¹⁾ A whistle fitted in a ship shall provide, in the direction of maximum intensity on the whistle and at a distance of 1 m from it, a sound pressure level in at least 1/3-octave band within the range of frequencies 180–700 Hz ($\pm 1\%$), of not less than appropriate figure given in the table.
- ²⁾ The range of audibility is for information only. It is approximately the range at which a whistle may be heard on its forward axis with 90% probability in conditions of still air on a ship having average background noise level at the listening post (taken to be 68 dB in the octave band centred on 250 Hz and 63 dB in the octave band centred on 500 Hz).

8.4.3 Bell and gong (acc. to COLREG 72, Annex III, p.2)

8.4.3.1 Bell and gong shall produce a sound pressure level of not less than 110 dB at a distance of 1 m from it.

8.4.3.2 The ship bell and gong shall give sonorous and clear tone. The bell shall be made of material not demanding application of corrosion-protective coating. Painting of the bell is admissible. The diameter of the mouth of the bell designated for ships of length 20 m and over shall be not less than 300 mm, and designated for ships of length 12 up to 20 m – not less than 200 mm. The mass of the striker shall be not less than 3% of the mass of the bell.

8.4.3.3 Gong shall be made of steel, bronze or other equivalent material. Gong shall be equipped with a hammer and a suitable device for its permanent suspension, and gong of a portable type - a device to hold it in hand. Steel gong shall have anticorrosion coating, but shall not be painted.

8.4.4 Signal shapes (acc. to COLREG 72, Annex I, p. 6 and Annex IV, p.1)

8.4.4.1 Shapes shall be black and of dimensions not less than specified in Table 8.4.4.1.

Table 8.4.4.1
Dimensions of shapes

No.	Name of shape	Dimensions, [m]	
		for ships of length 20 m and over	for ships of length less than 20 m
1	2	3	4
1	Ball	diameter 0,60	diameter 0,30
2	Cone	diameter of base and height 0,60	diameter of base and the height 0,30
3	Diamond (two cones)	small diagonal 0,6 great diagonal 1,2	small diagonal 0,3 great diagonal 0,6
4	Basket ¹⁾	–	–
5	Cylinder	diameter 0,60 and height 1,20	–

¹⁾ see 8.4.4.3

8.4.4.2 Signal shapes shall have adequate facilities for attaching them to the lines, by which they are raised, and for linking them with other shapes. Folding shapes shall be provided with means to maintain them unfolded and preventing

them from self-folding. Devices to connect shapes with each other shall provide for maintenance of spacing of at least 1.50 m for ships with a length of 20 m or greater, and of at least 1 m for ships less than 20 m. The cones shall have means to direct connection them with each other by tops or bases.

8.4.4.3 Basket's dimensions shall be not less than dimensions of signal shapes on board, and its shape shall differ from these shapes.

8.4.5 Pyrotechnic signal means (*acc. to LSA Code, Chapter III*)

8.4.5.1 General

Pyrotechnic signal means shall have functional characteristics defined in Table 3.5.1 and meet the following requirements:

- .1 shall not be subject to damage during storage at the ambient temperature within -30 °C to +65 °C;
- .2 their casing shall be waterproof and not subject to corrosion;
- .3 shall have brief instructions or diagrams clearly illustrating the use of the means, printed indelibly on its casing;
- .4 if the means manually operated, the activation shall take place from the base side of the means or act, for the safety reasons, with delay of 2 s;
- .5 ignition device shall be simple and not requiring for the operation special preparation and be easily activated in adverse conditions without the help of others - even with wet, cold hands or gloved hands;
- .6 ignition device of rocket flares and hand flares shall constitute an integral part of the means;
- .7 marking indicating the working life shall be indelible.

8.4.5.2 Rocket parachute flares (*acc. to LSA Code, Chapter III, p. 3.1*)

The rocket parachute flare shall:

- .1 be contained in a water-resistant casing;
- .2 have brief instructions or diagrams clearly illustrating the use of the rocket parachute flare printed on its casing;
- .3 have integral means of ignition; and
- .4 be so designed as not to cause discomfort to the person holding the casing when used in accordance with the manufacturer's operating instructions.

The rocket shall, when fired vertically, reach an altitude of not less than 300 m. At or near the top of its trajectory, the rocket shall eject a parachute flare, which shall:

- .1 burn with a bright red colour;
- .2 burn uniformly with an average luminous intensity of not less than 30,000 cd;
- .3 have a burning period of not less than 40 s;
- .4 have a rate of descent of not more than 5 m/s; and
- .5 not damage its parachute or attachments while burning.

8.4.5.3 Hand flares (*acc. to LSA Code, Chapter. III, p. 3.2.2*)

The hand flare shall:

- .1 be contained in a water-resistant casing;
- .2 have brief instructions or diagrams clearly illustrating the use of the hand flare printed on its casing;
- .3 be so designed as not to cause discomfort to the person holding the casing and not endanger the survival craft by burning or glowing residues when used in accordance with the manufacturer's operating instructions.
- .4 burn with a bright red colour;
- .5 burn uniformly with an average luminous intensity of not less than 15,000 cd;
- .6 have a burning period of not less than 1 min; and
- .7 continue to burn after having been immersed for a period of 10 s under 100 mm of water.

8.4.5.4 Buoyant smoke signals (*acc. to LSA Code, Chapter. III, p. 3.3 i 3.3.2*)

The buoyant smoke signal shall:

- .1 be contained in a water-resistant casing;
- .2 not ignite explosively when used in accordance with the manufacturer's operating instructions; and
- .3 have brief instructions or diagrams clearly illustrating the use of the buoyant smoke signal printed on its casing.
- .4 emit smoke of a highly visible colour at a uniform rate for a period of not less than 3 min when floating in calm water and continue to emit smoke when submerged in water for a period of 10 s under 100 mm of water;
- .5 not emit any flame during the entire smoke emission time;
- .6 not be swamped in a seaway.

8.4.6 Radar reflectors (*acc. to Res. A.384(X)*)

8.4.6.1 The ship with length less than 20 m shall, as far as practicable, be fitted with radar reflector. The radar reflector shall be so constructed, that the equivalent echoing areas for the frequency of 9.3 GHz (corresponding to a wavelength of 3.2 cm) could be detected using simple navigation radar within the range of 360°.

8.4.6.2 The radar reflector should be of an approved type with an adequate polar diagram in azimuth, and an echoing area preferably, of at least 10 m², mounted at a minimum height of 4 m above water level; or if this is not practicable, of at least 40 m², mounted at a minimum height of 2 m above water level. Reflectors should be capable of performance around 360° in azimuth using a typical marine navigational radar.

8.4.6.3 The echoing areas referred to in paragraph 8.4.6.2 correspond to the maximum values of the main lobes of the polar diagram.

8.4.6.4 The azimuthal polar diagram should be such that the response over a total angle of 240° is not less than —6dB with reference to the maxima of the main lobes and that the response should not remain below —6dB over any single angle of more than 10°.

8.4.6.5 The reflector should be capable of maintaining its reflection performance under the conditions of sea states, vibration, humidity and change of temperature likely to be experienced in the marine environment.

8.4.6.6 Fixing arrangements should be provided so that the reflector can be fitted either on a rigid mount or suspended in the rigging. If there is a preferred orientation of mounting this should be clearly marked on the reflector.

8.4.6.7 Active radar reflectors are subject of separate PRS consideration.

Table 8.4.5.4
Cechy użytkowe pirotechnicznych środków sygnałowych

No.	Signaling mean name	Colour of light or smoke	Luminous intensity ¹⁾ (minimum), [cd]	Altitude (minimum), [m]	Range of audibility ²⁾ (minimum), [Nm]	Burning period (minimum), [s]	Przeznaczenie
1	2	3	4	5	6	7	8
1	Rocket parachute flare (marine)	red	30 000	300	–	40	do wzywania pomocy
2	Sound rocket or petard	–	–	–	5	–	do wzywania pomocy
3	Hand flare	red	15 000	–	–	60	do wzywania pomocy
4	Hand flare	white	2000	–	–	60	do zwracania na siebie uwagi
5	Rocket flare	green	3000	80	–	6	do sygnalizacji ratowniczej
6	Rocket flare	red	3000	80	–	6	do sygnalizacji ratowniczej
7	Buoyant smoke signal	orange	–	–	–	180	do wzywania pomocy

¹⁾ Determined in laboratory.

²⁾ Determined over the water surface with wind strength of 1° Beauforta scale, clear air and the background noise up to 45 dB.

8.5 Installation requirements

8.5.1 General

8.5.1.1 The signal means shall be installed or stored in the ship in such a way, that are constantly ready for use.

8.5.1.2 For the basic and spare set of navigation lights permanent locations for their installation on the ship shall be provided.

8.5.1.3 Specified in the present chapter heights of the lights installation shall be considered as a minimum. If superstructures or ship's equipment may obscure light of the navigation lights, the heights shall be adequately increased. However these heights shall not exceed maximum heights specified in the present sub-chapter.

8.5.1.4 It is recommended that for ships equipped with the electric lights in the wheelhouse navigation lights' switchboard, equipped with optical-audio signalling, is provided. The navigation lights' switchboard shall satisfy the requirements of *Part VIII – Electric installations and control systems*, sub-chapter 6.8. On ships of less than 50 m and the objects without power drive, optical-audio signalling may not be installed if the location of the navigation lights provides visibility of the lights from the ship steering position or – where such position not provided – from the watchman position.

8.5.1.5 When installing signalling means fed with electric energy, the applicable requirements of *Part VIII – Electric installations and control systems* shall be taken into consideration.

8.5.1.6 The of the horizontal angle of light emission of 360°, except anchor lights, shall be installed in such a way that their lights are not obscured by the masts, stays or superstructures in the sectors greater than 6°. The light shall be considered as a light source with a diameter equal to the external diameter of the filament.

8.5.1.7 If meeting the requirements of point 8.5.1.6 is impossible, PRS may accept application of the lights system in place of one light. The system shall be designed so that the visibility of individual lanterns separately from any direction is excluded. The lights in the system shall be placed at the same level and screened so as to be visible, as far as possible, as a single light from a distance of one nautical mile.

8.5.1.8 If the installation of two or three lights in the vertical line is required, then the distance between them shall be:

- .1** on the ships of length 20 m and over the distance between lights shall be not less than 2 m, and the lowest one – with the exception of ships required to carry towing light – shall be not less than 4 m over the hull;

- .2 on the ships of length less than 20 m the distance between lights shall be not less than 1 m, and the lowest one – with the exception of ships required to carry towing light – shall be not less than 2 m over the hull;
- .3 if three lights are required, the distances between them shall be equal.

8.5.2 Essential lights on combat and support ships

(acc. to COLREG 72, Annex I, p. 2 a, b, c, d, e, f)

8.5.2.1 Masthead lights

8.5.2.1.1 The fore masthead light shall be installed on the fore mast or in front of the mast, and if the ship does not have the fore mast, in the forward part of the ship, in the plane of symmetry, at a height of not less than 6.0 m above the hull of the ship. If the width of the ship exceeds 6.0 m, the light shall be placed above the hull not less than the width of the ship, however it does not need to be at a height greater than 12.0 m above the hull. Masthead light of high-speed crafts with a length to width ratio less than 3.0 may be placed at a height, assumed in relation to the craft's width, less than provided for above, provided that the angles at the base of an isosceles triangle formed by the side lights and a masthead light, presented in the back projection, are not less than 27°.

8.5.2.1.2 The stern masthead light shall be installed in the plane of the ship's symmetry. The vertical distance between the fore and stern masthead lights shall not be less than 4,50 m, and moreover such, that for all normal states of the ship's trim, the light from the stern masthead light was, from a distance of 1000 m from the stem, visible over the fore masthead light and distinct from it, when viewed from the sea level. The horizontal distance between fore and stern masthead lights shall not be less than a half of the overall ship's length, but does not have to be greater than 100 m. The distance of the fore masthead light from the stem shall not be greater than one fourth of the ship's length. If on the ship of length less than 50 m one masthead light is installed it shall be located at the height prescribed in 8.5.2.1.1.

8.5.2.1.3 The masthead lights shall be located far away and over all other lights, as well as over the superstructures obscuring their visibility – in such a way, that the light of these lights is clearly visible, each separately, in the established for them sectors.

8.5.2.1.4 Under the masthead lights shall be provided horizontal screens with such dimensions that the lights do not project light on the navigation bridge or the other decks

8.5.2.2 Side lights *(acc. to COLREG 72, Annex I, p. 2 g, h, p.5)*

8.5.2.2.1 The light emitting green light shall be placed on the starboard, and emitting red light – on the port side in such a way, that both lights are arranged parallel and symmetrical in relation to the ship's plane of symmetry and at the same

line perpendicular to that plane. On ships with two masthead lights – fore and stern – side lights shall be placed behind the fore masthead light towards the stern, over the ship's hull at a height of not more than three quarters of height of the fore masthead light, whilst their place of installation shall be chosen so, that the visibility of the side lights is not reduced by the deck lights, and that these lights, as far as possible, are protected from being flooded by water.

If on the ship one masthead light is installed then sidelights may be placed forward of that light.

The side lights shall be installed on the navigation bridge wings in such a way that the distance between them is close to the width of the ship.

If for the design reasons the side lights may not be placed on the navigation bridge wings then, upon agreement with PRS, may be placed on the other deck.

8.5.2.2.2 Each side light shall be separated from inboard side by the screen provided with two lateral shields (fore and aft) placed perpendicular to the light screen.

Screens shall be of such length that the distance from the outer edge of the lens or plain glass of the light to the back edge of the fore transverse shield is not less than 0.90 m. The fore transverse shield shall be of such width that the line joining the outer edge with the inner edge of the filament was parallel to the ship's plane of symmetry. The aft shield shall be of such width that covering completely the light from the stern does not interfere with the visibility of light in the sector 22,5° abaft the beam.

The height of the screen and shields shall not be less than the height of the light housing.

Inner surfaces of the screens shall be mat black.

8.5.2.2.3 Screens of the lights shall be installed in such a way that their outer edges do not protrude beyond the line of the ship's side. The side lights shall be firmly attached to the screens.

8.5.2.2.4 In the case of application of the side lights folding inside the ship's side, the device shall be provided with efficient bolts ensuring proper installation of the lights when unfolded.

8.5.2.2.5 Instead of screens, for this purpose, the external wall of the bridge or wheelhouse can be used, provided that the requirements of points from 8.5.2.2.1 to 8.5.2.2.4 are satisfied.

8.5.2.2.6 On the pushed units the side lights shall be placed in the forward part of the object. Where electric lights are installed, their arrangement shall ensure that the following conditions are satisfied:

- .1 when the number of units is being pushed, only the side lights of the front unit are on;
- .2 when the group of units, coupled in pairs, is being pushed then on each leading unit only one side light shall be on, e.g. on the right unit – the starboard side light, and on the port side unit – the port side light.

8.5.2.3 Sternlight

Stern light shall be installed as close as possible to the ship's stern and the plane of symmetry.

8.5.2.4 Anchor light

8.5.2.4.1 The anchor lights shall be installed in fore and aft part of the ship, and the aft anchor light shall be placed at least lower than the fore anchor light. In the ships of length 50 m and over the fore anchor light shall be placed at the height not less than 6 m.

8.5.2.4.2 In the ships of length less than 50 m instead of two anchor lights, one anchor light, located in the best visible place, may be provided. In such ships installation of the aft anchor light is not obligatory, however where two anchor lights are provided they shall be placed in a way required by 8.5.2.4.1.

8.5.2.4.3 The anchor lights may be permanently installed on special stands or be hoisted by means of adequate device. The anchor lights shall be placed as close as possible to the extreme points of the bow and stern, in a place where their lights are best seen.

8.5.2.5 Emergency lights

8.5.2.5.1 Two emergency lights shall be placed in a best seen place, vertically one over the other, in accordance with the requirements of 8.5.1.7 and 8.5.1.8.

8.5.2.5.2 The emergency lights may be permanently installed on special stands or be hoisted by means of adequate device to the place where their lights are best seen.

In the new built ships the emergency lights shall be permanently fixed.

8.5.3 Signalling lamps (acc. to SOLAS 74, Chapter V, reg. 11)

8.5.3.1 Daylight signalling lamp

Daylight signalling lamp shall be kept in a wheelhouse or a in chart room and be always ready for use.

8.5.3.2 Manoeuvring light (acc. to COLREG 72, Annex I, p. 12)

The manoeuvring lamp shall be placed in the same vertical plane (parallel to the ship's plane of symmetry) as the fore and aft masthead lights and, if practicable – at height at least 2 m above the forward masthead light, provided that it shall be carried not less than 2 m above or below the after masthead light.

On a ship where only one masthead light is carried, the manoeuvring light shall be carried where it can be best seen and, if not practicable, not less than 2 m vertically apart from the masthead light.

The manoeuvring lamp shall be fitted so that its light can be seen all-round the ship.

If simultaneous light and sound signalling is arranged, separate light signalling shall also be provided.

8.5.4 Sound signal appliances (*acc. to COLREG 72, Annex III, p. 1 a, b, c, d, e, f, g*)

8.5.4.1 General

8.5.4.1.1 Sound signal appliances shall be installed in such a way that no part of the ship structure or her equipment creates obstacles for propagation of sounds emitted by those appliances or affects their intensity and purity.

8.5.4.1.2 The devices for activation of sound signal appliances shall be of design preventing self-emission of sound under influence of wind, snow, icing, etc.

8.5.4.2 Whistles

8.5.4.2.1 The whistle shall be installed so that the whistle centre was at least 2,5 m above the highest inter-side deck, and at least 0,5 m above the superstructure or other structures on that deck, which may hamper the propagation of sound.

The sound pressure level A of the ship's own signal at the listening post (navigation and bearing deck, wheelhouse and the bridge wings) shall not exceed 110 dB, and, so far as practicable, shall not exceed 100 dB.

The sound pressure level of a directional whistle shall be not more than 4 dB below the prescribed sound pressure level A on the axis at any direction in the horizontal plane within $\pm 45^\circ$ of the axis. At any other directions in the horizontal plane shall be not more than 10 dB below the prescribed sound pressure level A on the axis. The sound pressure level shall be measured in 1/3 octave band determining the range of audibility.

8.5.4.2.2 The system supplying steam or air shall be so arranged that the supply of these media, free of condensate, is ensured at all times and under any weather conditions.

8.5.4.2.3 For the control of the pneumatic whistle two independent electric circuits shall be provided, one supplied from the main, and the other from the emergency source of energy – or with one electric circuit capable to be supplied from both, the main and emergency source of energy provided that, additionally, manual control of the whistle is ensured.

Hand levers or buttons to control the whistle shall be placed in positions of the ship's steering. On the ships of unrestricted and restricted area at least one button (lever) in the wheelhouse and one button (lever) outside the wheelhouse, on each bridge wing (if the bridge wings provided in the ship). On the other ships at least one button (lever) shall be provided on each side of the bridge, except that in the ships of length less than 20 m only one button (lever) may be installed.

8.5.4.2.4 If on the ship whistles are installed at a distance of more than 100 m, it shall be so arranged that they are not sounded simultaneously.

If due to the presence of obstructions the sound field of a single whistle or one of the above whistles is likely to have a zone of greatly reduced signal level, it is recommended that a combined whistle system be fitted so as to overcome this reduction. The combined whistle system shall be regarded as a single whistle.

The whistles of a combined system shall be located at a distance apart of not more than 100 m and arranged to be sounded simultaneously. The frequency of any one whistle shall differ from those of the others by at least 10 Hz.

8.5.4.3 Ship bell (*acc. to COLREG 72, Annex III, p. 2 a, b, 3*)

The bell shall be permanently installed in a fore part of the ship in open area and placed in the vicinity of a windlass or a capstan and shall ensure a sound pressure level of not less than 110 dB at a distance of 1 m from it.

The bell shall be suspended in such a way that it can freely exercise swinging movements up to 50 ° in any direction, without touching any part of the construction or equipment of the ship.

8.5.4.4 Gong (*acc. to COLREG 72, Annex III, p. 2 a, b, 3*)

The gong shall be selected in such a way that its sound with respect to tone and sound quality is different from the sound of a bell installed in the ship, and shall ensure a sound pressure level of not less than 110 dB at a distance of 1 m from it.

Gong shall be installed as close as possible to the extreme end of the ship's stern, in such a place, that emitted by it sounds do not encounter any obstacles. Gong shall be suspended in accordance with the requirements of 8.5.4.3. If the weight of the gong does not exceed 5 kg, its permanent suspension is not mandatory. For the storage of such a gong special socket, placed in the stern of the ship, shall be provided. The gong striker shall be stored in a special slot in the immediate vicinity of the gong.

8.5.5 Devices for hoisting and storage of signal shapes

8.5.5.1 The ship shall carry adequate devices (masts, stays with sufficient quantity of signal lines) for hoisting of the signal shapes.

8.5.5.2 Signal shapes shall be stored in the vicinity of the navigation bridge or in the vicinity of the devices for their hoisting.

8.5.5.3 For non-propelled and unmanned ships the shapes may be stored in the towing or escorting ship.

9 REQUIREMENTS RELATING TO LOAD LINES CONVENTION, LL 1966

9.1 General

9.1.1 For each naval ship may be determined, in accordance with the regulations of the Annex to the *LL Convention 1966* (hereafter referred to *the Convention*), maximum allowable draught, then precisely and permanently marked on the ship's sides, and issue the *International Load Lines Certificate*, hereafter referred to *the Certificate*.

9.1.2 *The Certificate* is issued for the period not exceeding five years.

9.1.3 *The Certificate* can be issued for every ship which was subject of the survey required by *the Convention* and has been marked in accordance with *the Convention* requirements.

9.1.4 The ship shall be subject of the following surveys:

- .1 initial survey prior to the ship delivery,
- .2 survey for the renewal of *the Certificate*,
- .3 annual survey.

The Certificate is issued in a form conforming with samples demonstrated in the Annex to *the Convention*.

10 TONNAGE CERTIFICATES FOR SHIPS

10.1 General

Every naval ship may be provided with the following tonnage certificates:

- International Tonnage Certificate, 1969, or Tonnage Certificate;
- Suez Canal Special Tonnage Certificate,
- Panama Canal Tonnage Certificate.

10.1.1 *International Tonnage Certificate, 1969 or Tonnage Certificate* shall provide the value of gross tonnage and net tonnage of the ship, determined in accordance with Annex I to the *International Convention on Tonnage Measurement of Ships, 1969*.

Gross and net tonnage indicated in the above-mentioned tonnage certificates may be applied to determine the relevant requirements binding the existing ship under other international conventions, or for the determination of the canal and port charges, except charges for passage through the Suez Canal and the Panama Canal.

10.1.2 *Suez Canal Special Tonnage Certificate* applies to the fixing of charges for ship passage through the Suez Canal. Each naval ship passing through the Suez Canal shall be provided with such special tonnage certificate. In the case of its absence, net volume of the ship will be determined by the Canal staff by means of the approximate method, and will be applied at each crossing the Channel until the presentation by the ship a valid *Special Suez Canal Tonnage Certificate*.

10.1.3 For the passage through the Panama Canal naval ships, with the exception of support ships such as oil tankers and ships for transport ammunition, provisions, floating workshops, hospitals, ships to transport military supplies, etc., shall be provided with the documentation, which could be used to determine the displacement at each possible mean draught, since the fees for passing the Canal are determined in relation to displacement of the ship at the time of passing through the Canal.

Support vessel with an overall length of more than 30.48 meters (100 feet) shall be measured and provided with the *Panama Canal Tonnage Certificate*. Fees for passage through the Canal for such a ship will be determined on the basis of net tonnage indicated in the *Panama Canal Tonnage Certificate*.

The support ship with an overall length of less than 30.48 meters (100 feet) may not be measurement. Fees for such a ship passing the Canal is determined depending to its overall length.

10.1.4 Gross and net tonnage indicated in tonnage certificates other than *Suez Canal Special Tonnage Certificate* are given in absolute numbers. Gross and net tonnage reported in the *Suez Canal Special Tonnage Certificate* are given in RT, i.e., register tones. $1RT = 100 \text{ cubic feet} = 2.83 \text{ m}^3$.

10.2 Tonnage Certificates in accordance with the *International Convention on Tonnage Measurement of Ships, 1969*, (TONNAGE 1969)

10.2.1 The ship, for which the *International Tonnage Certificate, 1969*, or *Tonnage Certificate* is issued, shall be measured by the institution authorized by the administration of the State, which flag the ship flies, and its net and gross tonnage shall be determined in accordance with the Annex I to the *International Convention on Tonnage Measurements of Ships, 1969* (hereafter referred to *the TONNAGE 1969 Convention*), having regard to applicable IMO interpretations contained in Circulars concerning tonnage measurements of the ships.

Dimensions for calculations may be assumed on the basis of measurements of the ship (i.e. as built measurements), on the basis of the body lines, frame lines, offsets table or other structural drawings.

If establishing of the dimensions necessary for volumes calculations is possible on the basis of documentation, than, in each case, verification (control) measurements of the main dimensions of the ship, and random measurements of deck-houses, superstructures and other enclosed spaces of the ship shall be made. The ship's main dimensions control measurements may be carried out by the builder of the ship in witness of the authorized inspector.

Detailed manner of net and gross tonnage determination is described in issued by Polish Register of Shipping *Rules for Statutory Supervision of the Sea-going Ships, Part X – Tonnage Measurements of the Ships*. The above *Rules* in a part relating to ships, to which *the TONNAGE 69 Convention* applies, conform with its provisions and comprise relevant IMO interpretations contained in Circulars concerning tonnage measurements of the ships.

10.2.2 For ships engaged on international voyages *International Tonnage Certificate, 1969*, and for ships not engaged on international voyages *Tonnage Certificate* is issued. Definition of the international voyage is given in *TONNAGE 1969 Convention*.

10.3 Panama Canal Tonnage Certificate and special equipment

10.3.1 The requirements which shall be complied with by the support ships referred to in 10.1.3, passing the Panama Canal, including the requirements concerning measurements for determination of net tonnage and special equipment are included in *Panama Canal Regulations*.

10.3.2 Measurements and calculations for the net tonnage shall be made by authorized institution in conformity with the part *Rules for Measurement of Vessels* relating to the ships measurements of the above *Regulations*

10.3.3 On the basis of measurements and calculations authorized institution issues document called *PC/UMS Documentation of total volume*, containing all data necessary for net tonnage determination.

10.3.4 At the first passage through the Canal the above document is verified by the Panama Canal Administration, which on its base issues *Panama Canal Tonnage Certificate*. The *Certificate* is valid for the each next passage.

10.4 Suez Canal Special Tonnage Certificate

10.4.1 The requirements which shall be met by the ships passing the Suez Canal, including requirements for special equipment and capacity calculations, are contained in the provisions of navigation (*Rules of Navigation*) issued by the Suez Canal Administration. Provisions relating to the calculation of capacity are included in the section entitled *Tonnage and Dues*.

10.4.2 Measurements and calculation of net and gross tonnage shall be performed by the authorized institution. On their basis *Suez Canal Special Tonnage Certificate* is issued.

In *Suez Canal Special Tonnage Certificate* are presented values of net and gross tonnage and all data on which basis the capacities have been determined.

11 SURVEY OF STATUTORY EQUIPMENT MANUFACTURE

11.1 General

11.1.1 Products constituting statutory equipment of a ship are to be manufactured under PRS' direct or indirect survey performed under authorization of the Purchaser. Type of survey to be applied is determined by PRS.

11.1.2 Products manufactured under PRS' survey are to be subjected to the required tests and inspections at the manufacturers' or other laboratories and service stations accepted by PRS..

11.1.3 All the products shall be stamped in a way enabling their identification with the document confirming their manufacture under direct or indirect survey, or PRS type approval.

11.1.4 In well justified cases, in certificates issued as a result of a performed survey, PRS may specify special operating conditions for particular products.

11.1.5 As an equivalent to products of statutory equipment surveyed in accordance with the provisions of the present chapter, PRS may recognize products for which are issued relevant certificates and documents in result of application of procedures for compliance assessment specified in EU Directive 96/98/WE, concerning marine equipment.

11.2 Nadzór bezpośredni

11.2.1 Direct survey is carried out by PRS' Surveyors on the basis of approved technical documentation and applicable Conventions and Resolutions referred to in this Conventions, as well as on the basis of Rules or standards coordinated with PRS and possible additional applicable requirements. The range of examinations, measurements and tests, performed during survey is to be defined in test programme approved by PRS.

11.2.2 As a result of the performed survey and satisfactory tests of products, the following certificates are issued or confirmed by PRS:

- .1 PRS certificates for products;
- .2 PRS certificates on the performed tests.

11.2.3 PRS may apply indirect survey to a series production of products. The condition for the manufacturing of product under indirect survey is ensuring, by the manufacturer, a good and uniform standard of quality of series production. The mode and scope of indirect survey are specified by PRS.

11.3 Indirect survey

11.3.1 Indirect survey is carried out for products with PRS's *Type Approval Certificates* by manufacturer's technical services on the basis of technical documentation approved by PRS.

11.3.2 *Type Approval Certificate* is issued as a result of the following acceptance procedure:

- .1 the approval by PRS of technical documentation of product type;
- .2 the approval by PRS of programme of tests of product type;
- .3 inspection carried out by PRS' Surveyor at the manufacturer's works;
- .4 satisfactory tests results, confirming compliance of the product manufacture with the approved documentation.

11.3.3 Type tests are to be carried out according to the test programme agreed with PRS at the manufacturer's laboratory or at another laboratory recognized by PRS. PRS may recognize results of tests carried out without PRS' survey at the notified laboratory.

11.3.4 Każdy egzemplarz wyrobu uznanego typu powinien mieć zaświadczenie producenta stwierdzające jego zgodność z typem określonym w *Świadectwie uznania typu wyrobu* oraz zawierać dane, pozwalające na identyfikację wyrobu z wystawionym dla niego dokumentem.

11.3.5 *Type Approval Certificate* will cease to be valid in the following cases:

- .1 unsatisfactory service results;
- .2 changes in the structure or material of products without PRS' consent;
- .3 changes in the Rules or Type Approval Procedure.

11.4 Re-classification of statutory equipment

11.4.1 If the product which is intended to be installed on the ship does not document confirming that has been manufactured under PRS supervision, then the product, with the consent and under the conditions set by PRS, may be subject to re-classification..

11.4.2 The re-classification conditions are:

- .1 presentation to PRS a *Type Approval Certificate* issued by the other Classification Institution or by the authorized laboratory;
- .2 presentation to PRS a *Certificate of Compliance*, issued by the manufacturer of the product;
- .3 PRS approval of technical documentation and test programme of the product; and
- .4 Performance, with satisfactory results, of the product's tests under PRS supervision and, in well grounded cases, be the authorized by PRS service Firm.

In result of re-classification relevant *Certificate* for the single product is issued by PRS.

12 APPROVAL OF TESTING STATIONS, LABORATORIES, SERVICE SUPPLIERS, REPAIR AND MAINTENANCE WORKSHOPS

12.1 General

12.1.1 PRS may approve testing stations, laboratories, service suppliers and repair and maintenance workshops (further referred to as Firm) as competent to provide specified services for the purpose of PRS' survey by issuing certificates confirming this approval.

12.1.2 Where services mentioned in 12.1.1 are used by PRS' Surveyors in making decisions affecting issuance of *Certificates of Compliance*, the firms are subject to approval by PRS in accordance with the relevant procedures, e.g. those given in *Publication No. 51/P – Procedural Requirements for Service Suppliers*.

12.1.3 Where services mentioned in 12.1.1 are not directly used by PRS' Surveyors in making decisions affecting issuance of *Certificates of Compliance*, the firms are subject to approval by PRS in accordance with the relevant procedures, e.g. those given in *Publication No. 14/I – Principles of Recognition of Testing Stations and Maintenance Shops*.

12.1.4 The basic conditions for approval of the above organizations are:

- .1** suitable qualified personnel;
- .2** necessary instruments, machines and appliances for conducting tests and examinations, provided with valid legalization or control certificates;
- .3** the application of proper processes in the repair, maintenance or manufacture;
- .4** the application of appropriate supervision and verification system for all services provided.

12.1.5 *Approval Certificate* is issued with determined validity, e.g. of up to three years. PRS reserves the right to conduct inspection of the recognized organization in a mid-period of the *Approval Certificate* validity.

12.1.6 PRS may limit, suspend or withdraw the approval granted if major deficiencies in the Firm's activities have been observed and, adequately, invalidate or amend the *Approval Certificate* of the Firm.
